

# MOC3031M, MOC3032M, MOC3033M, MOC3041M, MOC3042M, MOC3043M

## 6-Pin DIP Zero-Cross Optoisolators Triac Driver Output (250/400 Volt Peak)

### Features

- Simplifies logic control of 115 VAC power
- Zero voltage crossing
- $dv/dt$  of 2000 V/ $\mu$ s typical, 1000 V/ $\mu$ s guaranteed
- VDE recognized (File # 94766), ordering option V (e.g., MOC3043VM)

### Applications

- |                           |                      |
|---------------------------|----------------------|
| ■ Solenoid/valve controls | ■ Lighting controls  |
| ■ Static power switches   | ■ AC motor drives    |
| ■ Temperature controls    | ■ E.M. contactors    |
| ■ AC motor starters       | ■ Solid state relays |

### Description

The MOC303XM and MOC304XM devices consist of a AlGaAs infrared emitting diode optically coupled to a monolithic silicon detector performing the function of a zero voltage crossing bilateral triac driver.

They are designed for use with a triac in the interface of logic systems to equipment powered from 115 VAC lines, such as teletypewriters, CRTs, solid-state relays, industrial controls, printers, motors, solenoids and consumer appliances, etc.

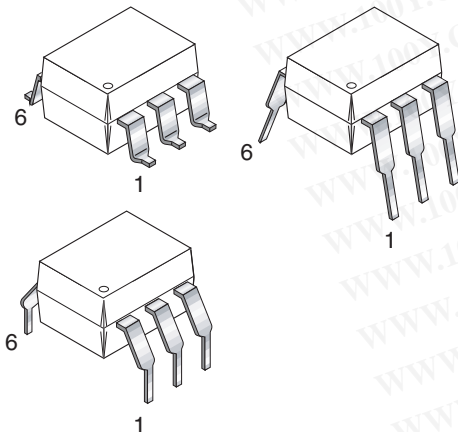

### Schematic

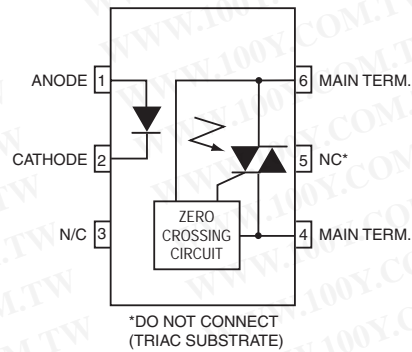

勝特力材料 886-3-5753170  
 勝特力电子(上海) 86-21-54151736  
 勝特力电子(深圳) 86-755-83298787  
[Http://www.100y.com.tw](http://www.100y.com.tw)

### Absolute Maximum Ratings ( $T_A = 25^\circ\text{C}$ unless otherwise noted)

Parameters	Symbol	Device	Value	Units
<b>TOTAL DEVICE</b>				
Storage Temperature	$T_{STG}$	All	-40 to +150	$^\circ\text{C}$
Operating Temperature	$T_{OPR}$	All	-40 to +85	$^\circ\text{C}$
Lead Solder Temperature	$T_{SOL}$	All	260 for 10 sec	$^\circ\text{C}$
Junction Temperature Range	$T_J$	All	-40 to +100	$^\circ\text{C}$
Isolation Surge Voltage <sup>(1)</sup> (peak AC voltage, 60Hz, 1 sec duration)	$V_{ISO}$	All	7500	Vac(pk)
Total Device Power Dissipation @ 25 $^\circ\text{C}$ Derate above 25 $^\circ\text{C}$	$P_D$	All	250 2.94	mW mW/ $^\circ\text{C}$
<b>EMITTER</b>				
Continuous Forward Current	$I_F$	All	60	mA
Reverse Voltage	$V_R$	All	6	V
Total Power Dissipation 25 $^\circ\text{C}$ Ambient Derate above 25 $^\circ\text{C}$	$P_D$	All	120 1.41	mW mW/ $^\circ\text{C}$
<b>DETECTOR</b>				
Off-State Output Terminal Voltage	$V_{DRM}$	MOC3031M/2M/3M MOC3041M/2M/3M	250 400	V
Peak Repetitive Surge Current (PW = 100 $\mu\text{s}$ , 120 pps)	$I_{TSM}$	All	1	A
Total Power Dissipation @ 25 $^\circ\text{C}$ Ambient Derate above 25 $^\circ\text{C}$	$P_D$	All	150 1.76	mW mW/ $^\circ\text{C}$

#### Note

1. Isolation surge voltage,  $V_{ISO}$ , is an internal device dielectric breakdown rating. For this test, Pins 1 and 2 are common, and Pins 4, 5 and 6 are common.

### Electrical Characteristics ( $T_A = 25^\circ\text{C}$ Unless otherwise specified)

#### Individual Component Characteristics

Parameters	Test Conditions	Symbol	Device	Min	Typ	Max	Units
<b>EMITTER</b>							
Input Forward Voltage	$I_F = 30\text{ mA}$	$V_F$	All		1.25	1.5	V
Reverse Leakage Current	$V_R = 6\text{ V}$	$I_R$	All		0.01	100	$\mu\text{A}$
<b>DETECTOR</b>							
Peak Blocking Current, Either Direction	Rated $V_{DRM}$ , $I_F = 0$ (note 1)	$I_{DRM1}$	All			100	nA
Peak On-State Voltage, Either Direction	$I_{TM} = 100\text{ mA peak}$ , $I_F = 0$	$V_{TM}$	All		1.8	3	V
Critical Rate of Rise of Off-State Voltage	$I_F = 0$ (Figure 9, note 3)	dv/dt	All	1000			V/ $\mu\text{s}$

#### Transfer Characteristics ( $T_A = 25^\circ\text{C}$ Unless otherwise specified.)

DC Characteristics	Test Conditions	Symbol	Device	Min	Typ	Max	Units
LED Trigger Current	Main terminal voltage = 3V (note 2)	$I_{FT}$	MOC3031M/ MOC3041M MOC3032M/ MOC3042M MOC3033M/ MOC3043M			15 10 5	mA
Holding Current, Either Direction		$I_H$	All		400		$\mu\text{A}$

**Zero Crossing Characteristics** ( $T_A = 25^\circ\text{C}$  Unless otherwise specified.)

Characteristics	Test Conditions	Symbol	Device	Min	Typ	Max	Units
Inhibit Voltage	$I_F = \text{rated } I_{FT}$ , MT1-MT2 voltage above which device will not trigger off-state	$V_{IH}$	All			20	V
Leakage in Inhibited State	$I_F = \text{rated } I_F$ , rated $V_{DRM}$ , off-state	$I_{DRM2}$	All			500	$\mu\text{A}$

**Note**

1. Test voltage must be applied within dv/dt rating.
2. All devices are guaranteed to trigger at an  $I_F$  value less than or equal to max  $I_{FT}$ . Therefore, recommended operating  $I_F$  lies between max  $I_{FT}$  (15 mA for MOC3031M & MOC3041M, 10 mA for MOC3032M & MOC3042M, 5 mA for MOC3033M & MOC3043M) and absolute max  $I_F$  (60 mA).
3. This is static dv/dt. See Figure 9 for test circuit. Commutating dv/dt is a function of the load-driving thyristor(s) only.

**勝特力材料 886-3-5753170**  
**勝特力电子(上海) 86-21-54151736**  
**勝特力电子(深圳) 86-755-83298787**  
[Http://www.100y.com.tw](http://www.100y.com.tw)

Figure 1. LED Forward Voltage vs. Forward Current

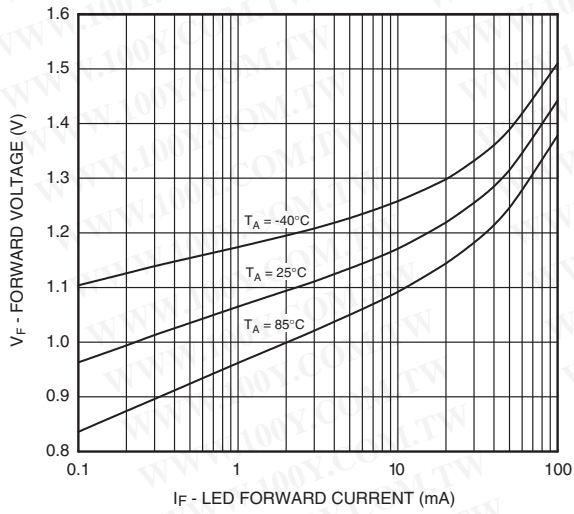

Figure 2. On-State Characteristics

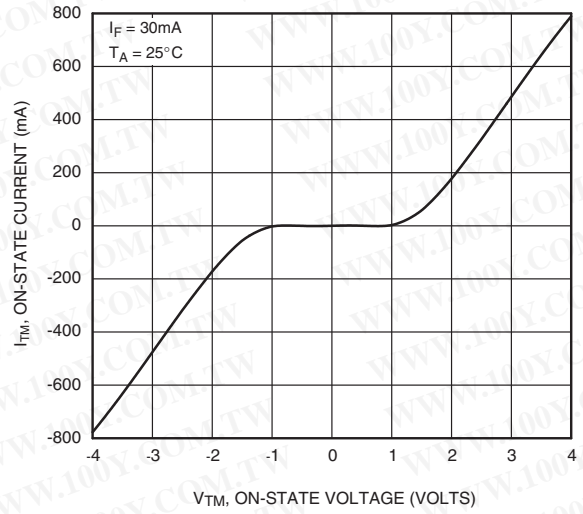

Figure 3. Trigger Current vs. Temperature

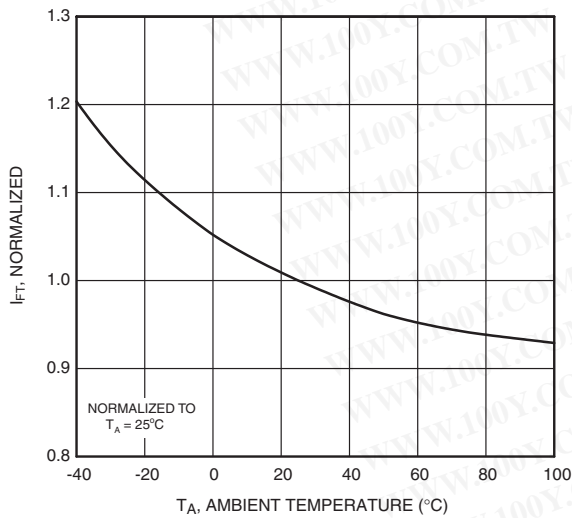
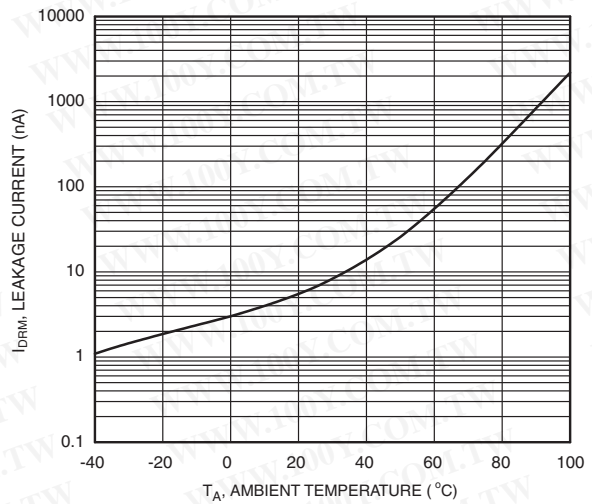

Figure 4. Leakage Current,  $I_{DRM}$  vs. Temperature



勝特力材料 886-3-5753170  
 勝特力电子(上海) 86-21-54151736  
 勝特力电子(深圳) 86-755-83298787  
[Http://www.100y.com.tw](http://www.100y.com.tw)

Figure 5.  $I_{DRM2}$  - Leakage in Inhibit State vs. Temperature

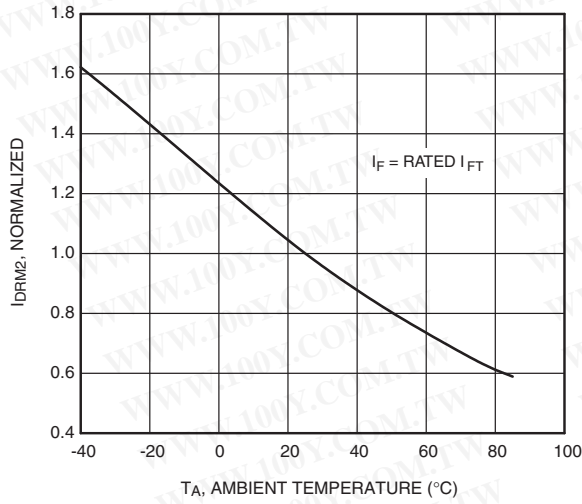

Figure 6. LED Current Required to Trigger vs. LED Pulse Width

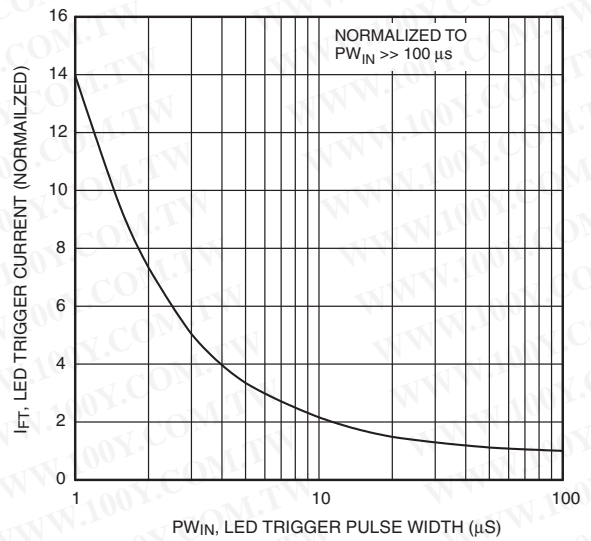

Figure 7. Holding Current,  $I_H$  vs. Temperature

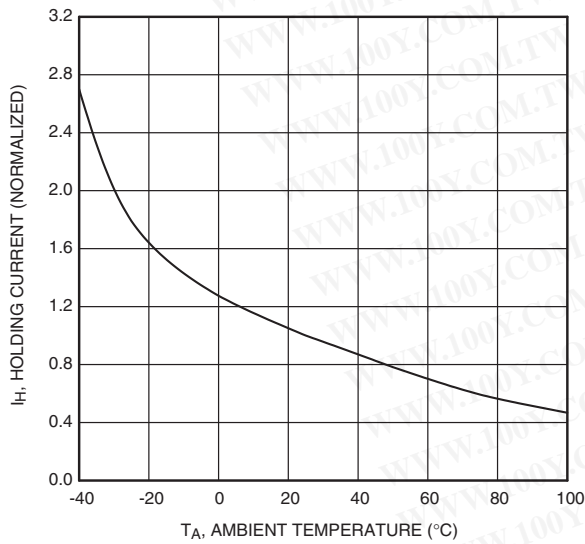
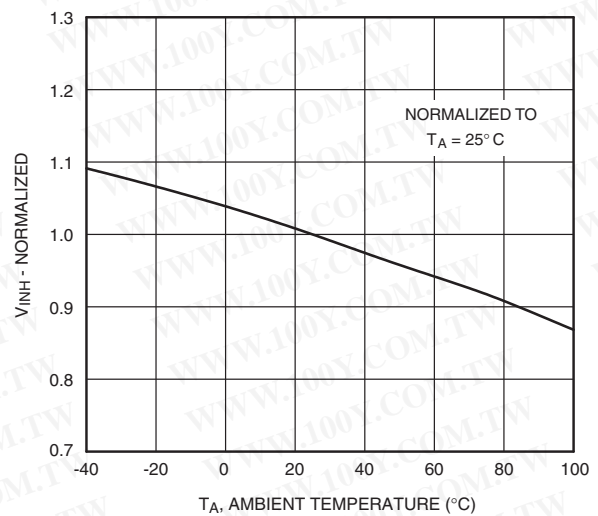

Figure 8. Inhibit Voltage vs. Temperature



勝特力材料 886-3-5753170  
 勝特力电子(上海) 86-21-54151736  
 勝特力电子(深圳) 86-755-83298787  
[Http://www.100y.com.tw](http://www.100y.com.tw)

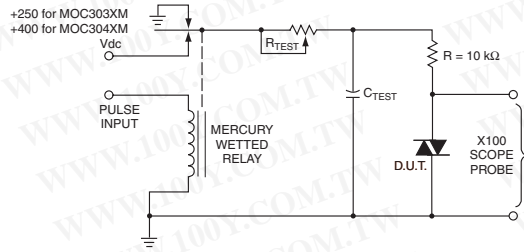

Figure 9. Static dv/dt Test Circuit

1. The mercury wetted relay provides a high speed repeated pulse to the D.U.T.
2. 100x scope probes are used, to allow high speeds and voltages.
3. The worst-case condition for static dv/dt is established by triggering the D.U.T. with a normal LED input current, then removing the current. The variable  $R_{TEST}$  allows the dv/dt to be gradually increased until the D.U.T. continues to trigger in response to the applied voltage pulse, even after the LED current has been removed. The dv/dt is then decreased until the D.U.T. stops triggering.  $\tau_{RC}$  is measured at this point and recorded.

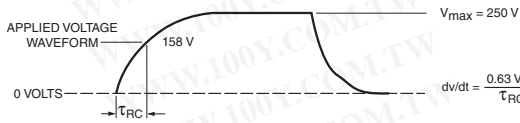

Figure 10. Static dv/dt Test Waveform (MOC3031M, MOC3032M, MOC3033M)

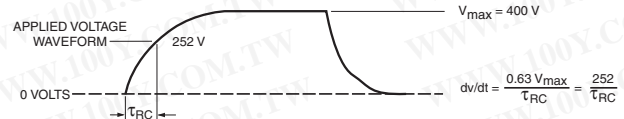
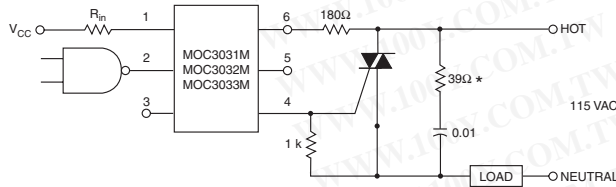

Figure 11. Static dv/dt Test Waveform (MOC3041M, MOC3042M, MOC3043M)

Typical circuit (Fig 12, 13) for use when hot line switching is required. In this circuit the “hot” side of the line is switched and the load connected to the cold or neutral side. The load may be connected to either the neutral or hot line.

$R_{in}$  is calculated so that  $I_F$  is equal to the rated  $I_{FT}$  of the part, 5 mA for the MOC3033M and MOC3043M, 10 mA for the MOC3032M and MOC3042M, or 15 mA for the MOC3031M and MOC3041M. The 39 ohm resistor and 0.01  $\mu$ F capacitor are for snubbing of the triac and may or may not be necessary depending upon the particular triac and load used.



\*For highly inductive loads (power factor < 0.5), change this value to 360 ohms.

Figure 12. Hot-Line Switching Application Circuit (MOC3031M, MOC3032M, MOC3033M)

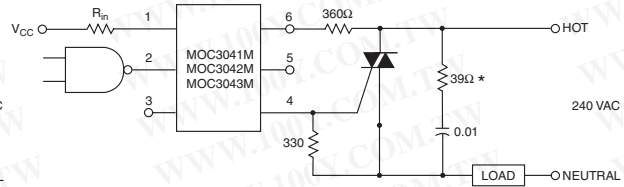

\*For highly inductive loads (power factor < 0.5), change this value to 360 ohms.

Figure 13. Hot-Line Switching Application Circuit (MOC3041M, MOC3042M, MOC3043M)

勝特力材料 886-3-5753170  
 勝特力电子(上海) 86-21-54151736  
 勝特力电子(深圳) 86-755-83298787  
[Http://www.100y.com.tw](http://www.100y.com.tw)

勝特力材料 886-3-5753170  
 勝特力电子(上海) 86-21-54151736  
 勝特力电子(深圳) 86-755-83298787  
[Http://www.100y.com.tw](http://www.100y.com.tw)

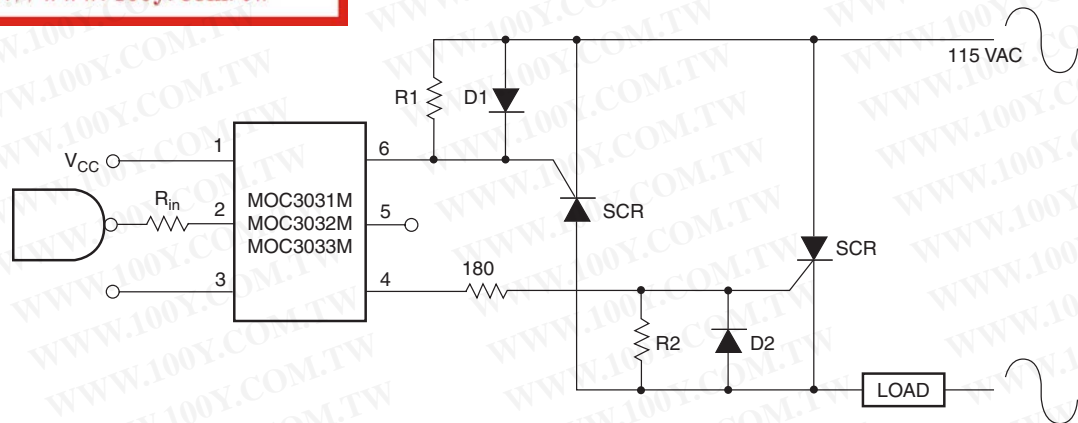

**Figure 14. Inverse-Parallel SCR Driver Circuit (MOC3031M, MOC3032M, MOC3033M)**

Suggested method of firing two, back-to-back SCR's with a Fairchild triac driver. Diodes can be 1N4001; resistors, R1 and R2, are optional 1 k ohm.

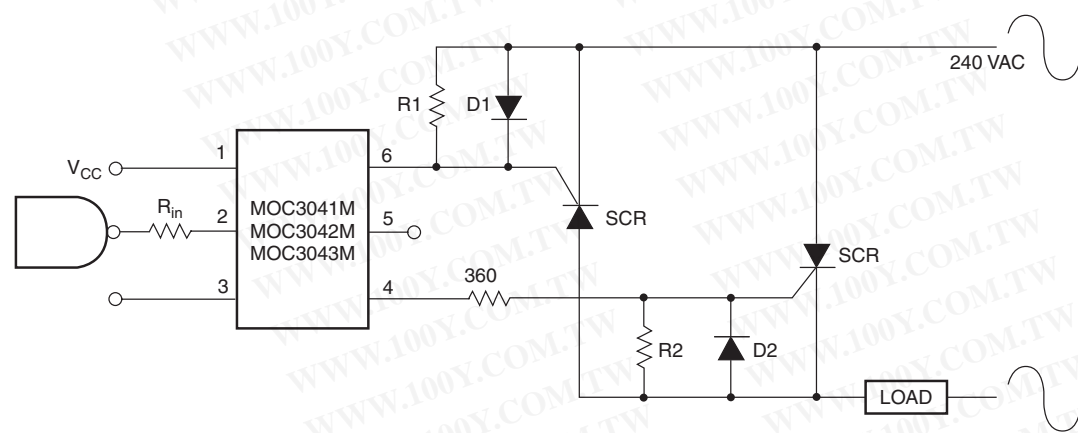
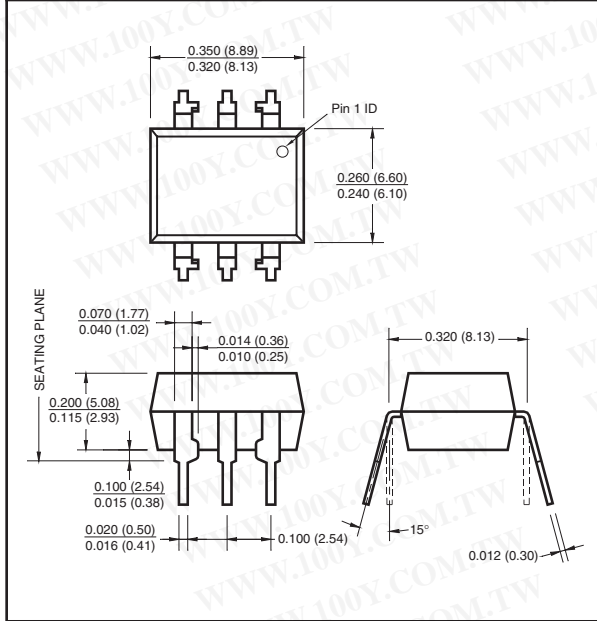

**Figure 15. Inverse-Parallel SCR Driver Circuit (MOC3041M, MOC3042M, MOC3043M)**

Suggested method of firing two, back-to-back SCR's with a Fairchild triac driver. Diodes can be 1N4001; resistors, R1 and R2, are optional 330 ohm.

Note: This optoisolator should not be used to drive a load directly. It is intended to be a trigger device only.

### Package Dimensions (Through Hole)



### Package Dimensions (Surface Mount)

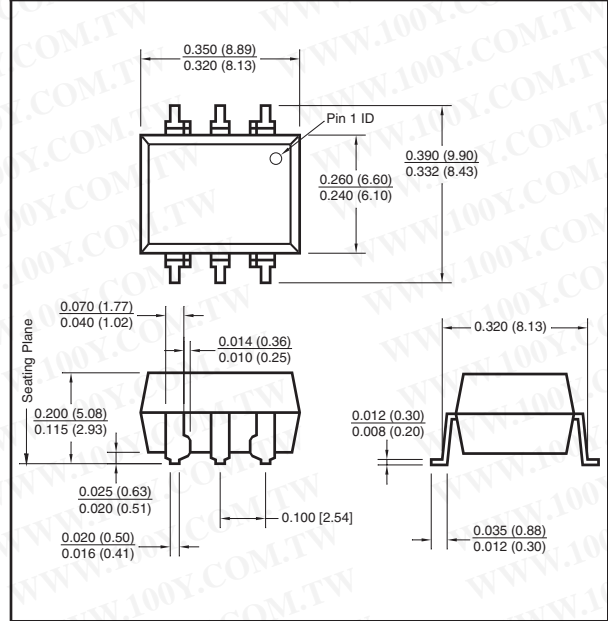

### Package Dimensions (0.4" Lead Spacing)

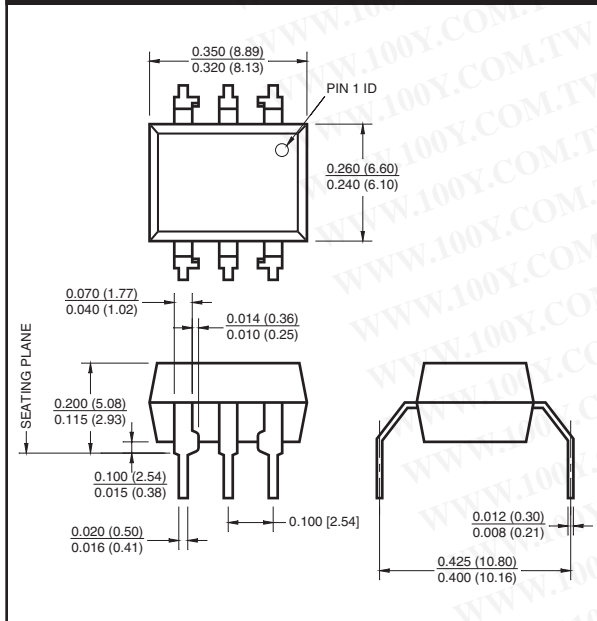

### Recommended Pad Layout for Surface Mount Leadform

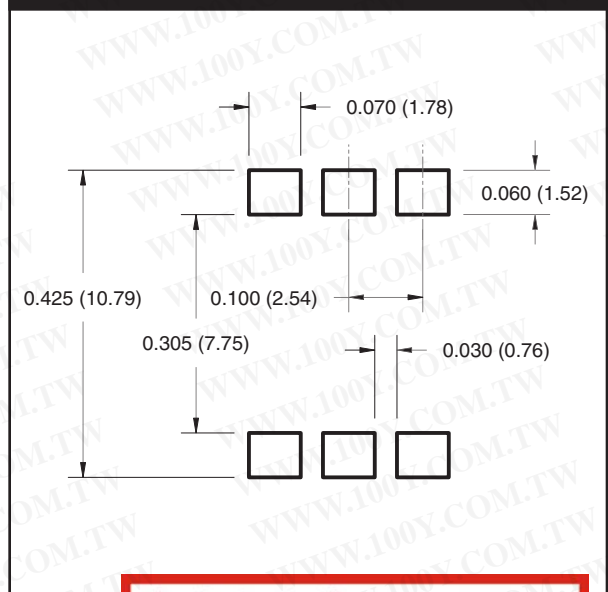

**NOTE**

All dimensions are in inches (millimeters)

勝特力材料 886-3-5753170  
 勝特力电子(上海) 86-21-54151736  
 勝特力电子(深圳) 86-755-83298787  
[Http://www.100y.com.tw](http://www.100y.com.tw)



## Ordering Information

Option	Order Entry Identifier	Description
S	S	Surface Mount Lead Bend
SR2	SR2	Surface Mount; Tape and reel
T	T	0.4" Lead Spacing
V	V	VDE 0884
TV	TV	VDE 0884, 0.4" Lead Spacing
SV	SV	VDE 0884, Surface Mount
SR2V	SR2V	VDE 0884, Surface Mount, Tape & Reel

### Carrier Tape Specifications (White Package, -M Suffix)

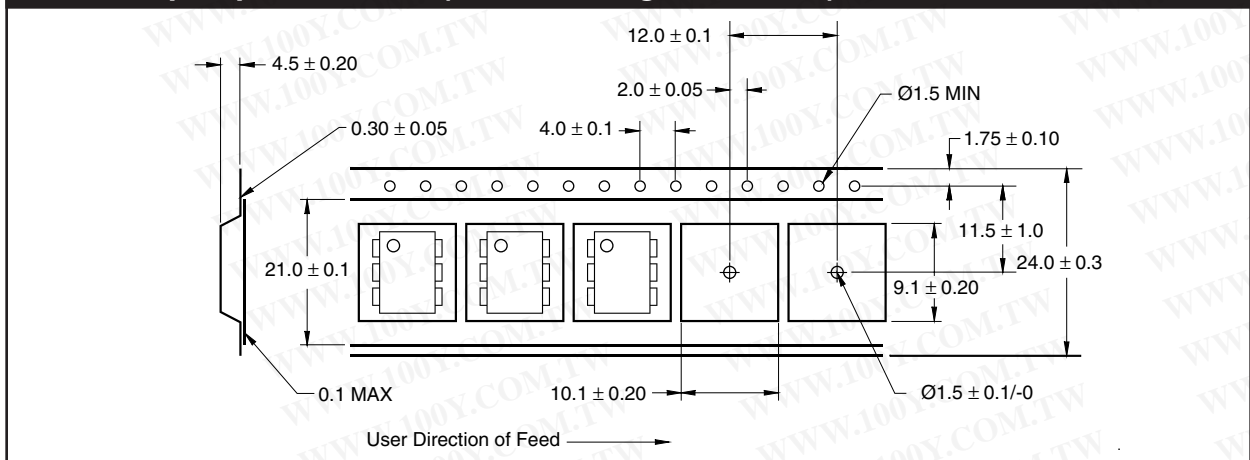

#### NOTE

All dimensions are in inches (millimeters)

勝特力材料 886-3-5753170  
 勝特力电子(上海) 86-21-54151736  
 勝特力电子(深圳) 86-755-83298787  
[Http://www.100y.com.tw](http://www.100y.com.tw)

## Marking Information

勝特力材料 886-3-5753170  
 勝特力电子(上海) 86-21-54151736  
 勝特力电子(深圳) 86-755-83298787  
[Http://www.100y.com.tw](http://www.100y.com.tw)

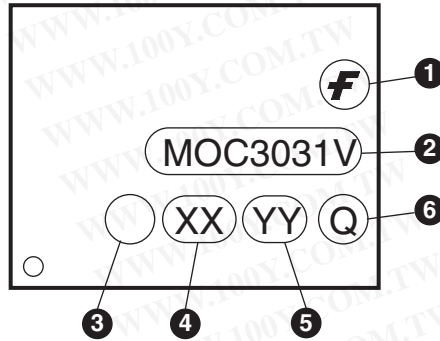

### Definitions

1	Fairchild logo
2	Device number
3	VDE mark (Note: Only appears on parts ordered with VDE option – See order entry table)
4	One digit year code, e.g., '3'
5	Two digit work week ranging from '01' to '53'
6	Assembly package code

\*Note – Parts that do not have the 'V' option (see definition 3 above) that are marked with date code '325' or earlier are marked in portrait format.

### Reflow Profile (White Package, -M Suffix)

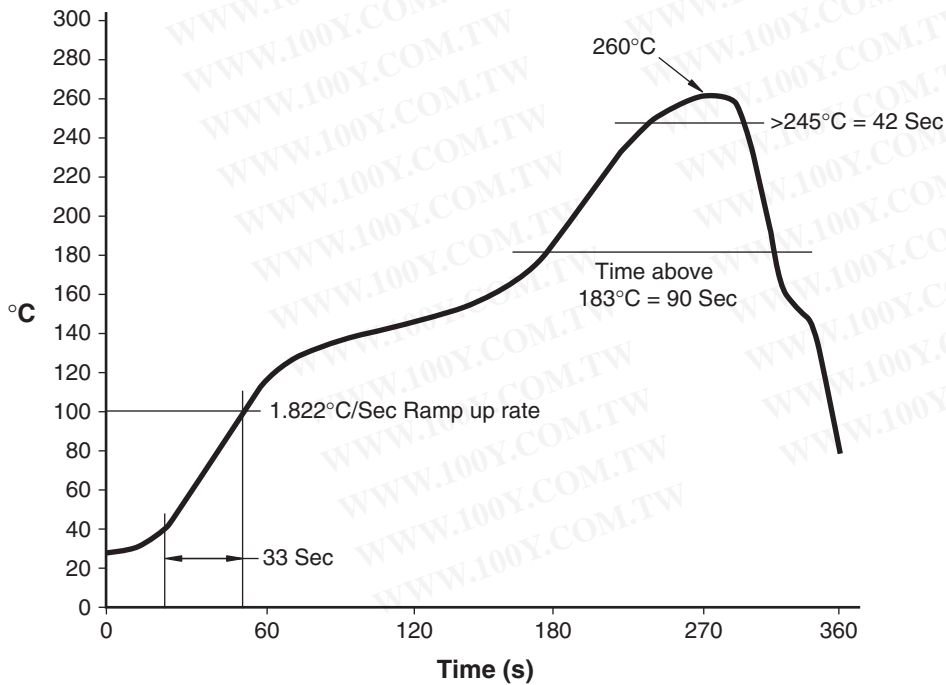

## TRADEMARKS

The following are registered and unregistered trademarks Fairchild Semiconductor owns or is authorized to use and is not intended to be an exhaustive list of all such trademarks.

ACEx™	FAST®	ISOPLANAR™	PowerSaver™	SuperSOT™-8
ActiveArray™	FASTr™	LittleFET™	PowerTrench®	SyncFET™
Bottomless™	FPST™	MICROCOUPLER™	QFET®	TinyLogic®
Build it Now™	FRFET™	MicroFET™	QS™	TINYOPTO™
CoolFET™	GlobalOptoisolator™	MicroPak™	QT Optoelectronics™	TruTranslation™
CROSSVOLT™	GTO™	MICROWIRE™	Quiet Series™	UHC™
DOME™	HiSeC™	MSX™	RapidConfigure™	UltraFET®
EcoSPARK™	I <sup>2</sup> C™	MSXPro™	RapidConnect™	UniFET™
E <sup>2</sup> C MOS™	i-Lo™	OCX™	μSerDes™	VCX™
EnSigna™	ImpliedDisconnect™	OCXPro™	SILENT SWITCHER®	Wire™
FACT™	IntelliMAX™	OPTOLOGIC®	SMART START™	
FACT Quiet Series™		OPTOPLANAR™	SPM™	
Across the board. Around the world.™		PACMAN™	Stealth™	
The Power Franchise®		POP™	SuperFET™	
Programmable Active Droop™		Power247™	SuperSOT™-3	
		PowerEdge™	SuperSOT™-6	

## DISCLAIMER

FAIRCHILD SEMICONDUCTOR RESERVES THE RIGHT TO MAKE CHANGES WITHOUT FURTHER NOTICE TO ANY PRODUCTS HEREIN TO IMPROVE RELIABILITY, FUNCTION OR DESIGN. FAIRCHILD DOES NOT ASSUME ANY LIABILITY ARISING OUT OF THE APPLICATION OR USE OF ANY PRODUCT OR CIRCUIT DESCRIBED HEREIN; NEITHER DOES IT CONVEY ANY LICENSE UNDER ITS PATENT RIGHTS, NOR THE RIGHTS OF OTHERS.

## LIFE SUPPORT POLICY

FAIRCHILD'S PRODUCTS ARE NOT AUTHORIZED FOR USE AS CRITICAL COMPONENTS IN LIFE SUPPORT DEVICES OR SYSTEMS WITHOUT THE EXPRESS WRITTEN APPROVAL OF FAIRCHILD SEMICONDUCTOR CORPORATION. As used herein:

1. Life support devices or systems are devices or systems which, (a) are intended for surgical implant into the body, or (b) support or sustain life, or (c) whose failure to perform when properly used in accordance with instructions for use provided in the labeling, can be reasonably expected to result in significant injury to the user.
2. A critical component is any component of a life support device or system whose failure to perform can be reasonably expected to cause the failure of the life support device or system, or to affect its safety or effectiveness.

## PRODUCT STATUS DEFINITIONS

### Definition of Terms

Datasheet Identification	Product Status	Definition
Advance Information	Formative or In Design	This datasheet contains the design specifications for product development. Specifications may change in any manner without notice.
Preliminary	First Production	This datasheet contains preliminary data, and supplementary data will be published at a later date. Fairchild Semiconductor reserves the right to make changes at any time without notice in order to improve design.
No Identification Needed	Full Production	This datasheet contains final specifications. Fairchild Semiconductor reserves the right to make changes at any time without notice in order to improve design.
Obsolete	Not In Production	This datasheet contains specifications on a product that has been discontinued by Fairchild semiconductor. The datasheet is printed for reference information only.