

**MCT2
MCT2200**

**MCT2E
MCT2201**

**MCT210
MCT2202**

MCT271

WHITE PACKAGE (-M SUFFIX)

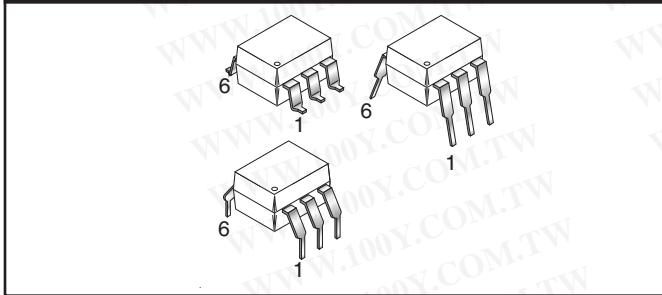

BLACK PACKAGE (NO -M SUFFIX)

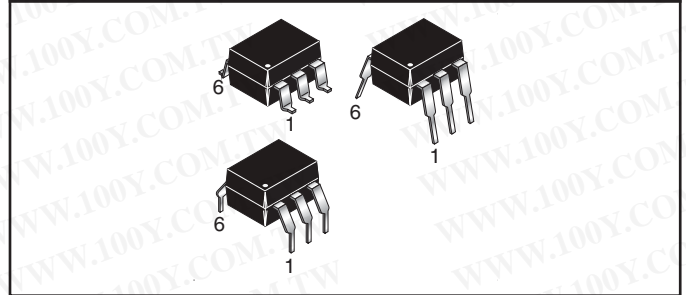

DESCRIPTION

The MCT2XXX series optoisolators consist of a gallium arsenide infrared emitting diode driving a silicon phototransistor in a 6-pin dual in-line package.

FEATURES

- UL recognized (File # E90700)
- VDE recognized (File # 94766)
 - Add option V for white package (e.g., MCT2V-M)
 - Add option 300 for black package (e.g., MCT2.300)
- MCT2 and MCT2E are also available in white package by specifying -M suffix, eg. MCT2-M

APPLICATIONS

- Power supply regulators
- Digital logic inputs
- Microprocessor inputs

勝特力材料 886-3-5753170
 勝特力电子(上海) 86-21-54151736
 勝特力电子(深圳) 86-755-83298787
[Http://www.100y.com.tw](http://www.100y.com.tw)

SCHEMATIC

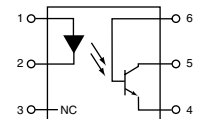

PIN 1. ANODE
 2. CATHODE
 3. NO CONNECTION
 4. EMITTER
 5. COLLECTOR
 6. BASE

**MCT2
MCT2200**

**MCT2E
MCT2201**

**MCT210
MCT2202**

MCT271

ABSOLUTE MAXIMUM RATINGS

Parameter	Symbol	Device	Value	Units
TOTAL DEVICE Storage Temperature	T_{STG}	ALL	-55 to +150	°C
Operating Temperature	T_{OPR}	ALL	-55 to +100	°C
Lead Solder Temperature	T_{SOL}	ALL	260 for 10 sec	°C
Total Device Power Dissipation @ $T_A = 25^\circ\text{C}$	P_D	-M	250	mW
		Non-M	260	
Derate above 25°C		-M	2.94	mW/°C
		Non-M	3.3	
EMITTER DC/Average Forward Input Current	I_F	-M	60	mA
		Non-M	100	
Reverse Input Voltage	V_R	ALL	3	V
Forward Current - Peak (300µs, 2% Duty Cycle)	$I_F(pk)$	ALL	3	A
LED Power Dissipation @ $T_A = 25^\circ\text{C}$	P_D	-M	120	mW
		Non-M	150	
Derate above 25°C		-M	1.41	mW/°C
		Non-M	2.0	
DETECTOR Collector Current	I_C	ALL	50	mA
Collector-Emitter Voltage	V_{CEO}	ALL	30	V
Detector Power Dissipation @ $T_A = 25^\circ\text{C}$	P_D	ALL	150	mW
Derate above 25°C		-M	1.76	mW/°C
		Non-M	2.0	

勝特力材料 886-3-5753170
 勝特力电子(上海) 86-21-54151736
 勝特力电子(深圳) 86-755-83298787
[Http://www.100y.com.tw](http://www.100y.com.tw)

MCT2
MCT2200

MCT2E
MCT2201

MCT210
MCT2202

MCT271

ELECTRICAL CHARACTERISTICS ($T_A = 25^\circ\text{C}$ Unless otherwise specified.)

Individual Component Characteristics

Parameter	Test Conditions	Symbol	Device	Min	Typ**	Max	Unit
EMITTER Input Forward Voltage	($I_F = 20 \text{ mA}$)	V_F	MCT2/-M MCT2E/-M MCT271 MCT2200 MCT2201 MCT2202		1.25	1.50	V
	($T_A = 0-70^\circ\text{C}$, $I_F = 40 \text{ mA}$)		MCT210		1.33		
Reverse Leakage Current	($V_R = 3.0 \text{ V}$)	I_R	MCT2/-M MCT2E/-M MCT271 MCT2200 MCT2201 MCT2202		0.001	10	μA
	($T_A = 0-70^\circ\text{C}$, $V_R = 6.0 \text{ V}$)		MCT210				
DETECTOR Collector-Emitter Breakdown Voltage	($I_C = 1.0 \text{ mA}$, $I_F = 0$)	BV_{CEO}	ALL	30	100		V
	($T_A = 0-70^\circ\text{C}$)		MCT210				
Collector-Base Breakdown Voltage	($I_C = 10 \mu\text{A}$, $I_F = 0$)	BV_{CBO}	MCT2/-M MCT2E/-M MCT271 MCT2200 MCT2201 MCT2202	70	120		V
	($T_A = 0-70^\circ\text{C}$)		MCT210	30			
Emitter-Collector Breakdown Voltage	($I_E = 100 \mu\text{A}$, $I_F = 0$)	BV_{ECO}	MCT2/-M MCT2E/-M MCT271 MCT2200 MCT2201 MCT2202	7	10		V
	($T_A = 0-70^\circ\text{C}$)		MCT210	6	10		
Collector-Emitter Dark Current	($V_{CE} = 10 \text{ V}$, $I_F = 0$)	I_{CEO}	ALL		1	50	nA
	($V_{CE} = 5 \text{ V}$, $T_A = 0-70^\circ\text{C}$)						30
Collector-Base Dark Current	($V_{CB} = 10 \text{ V}$, $I_F = 0$)	I_{CBO}	ALL			20	nA
Capacitance	($V_{CE} = 0 \text{ V}$, $f = 1 \text{ MHz}$)	C_{CE}	ALL		8		pF

勝特力材料 886-3-5753170
勝特力电子(上海) 86-21-54151736
勝特力电子(深圳) 86-755-83298787
[Http://www.100y.com.tw](http://www.100y.com.tw)

** Typical values at $T_A = 25^\circ\text{C}$

**MCT2
MCT2200**

**MCT2E
MCT2201**

**MCT210
MCT2202**

MCT271

TRANSFER CHARACTERISTICS ($T_A = 25^\circ\text{C}$ Unless otherwise specified.)

DC Characteristic	Test Conditions	Symbol	Device	Min	Typ**	Max	Unit
Output Collector Current	($T_A = 0\text{-}70^\circ\text{C}$)	CTR	MCT210	150			%
	(I _F = 10 mA, V _{CE} = 5 V)		MCT2200	20			
			MCT2201	100			
			MCT2202	63		125	
	(I _F = 10 mA, V _{CE} = 10 V)		MCT2 MCT2-M MCT2E MCT2E-M	20			
(I _F = 3.2 mA to 32 mA, V _{CE} = 0.4 V) ($T_A = 0\text{-}70^\circ\text{C}$)	MCT271	45		90			
Collector-Emitter Saturation Voltage	(I _C = 2 mA, I _F = 16 mA)	V _{CE (SAT)}	MCT2 MCT2-M MCT2E MCT2E-M MCT271			0.4	V
	(I _C = 16 mA, I _F = 32 mA, $T_A = 0\text{-}70^\circ\text{C}$)		MCT210				
	(I _C = 2.5 mA, I _F = 10 mA)		MCT2200 MCT2201 MCT2202				
AC Characteristic Saturated Turn-on Time from 5 V to 0.8 V	(I _F = 15 mA, V _{CC} = 5 V, R _L = 2 kΩ) (R _B = Open) (Fig. 20)	t _{on}	MCT2		1.1		μs
	(I _F = 20 mA, V _{CC} = 5 V, R _L = 2 kΩ) (R _B = 100 kΩ) (Fig. 20)		MCT2E		1.1		
Saturated Turn-off Time from SAT to 2.0 V	(I _F = 15 mA, V _{CC} = 5 V, R _L = 2 kΩ) (R _B = Open) (Fig. 20)	t _{off}	MCT2		1.3		
	(I _F = 20 mA, V _{CC} = 5 V, R _L = 2 kΩ) (R _B = 100 kΩ) (Fig. 20)		MCT2E		1.3		
Turn-on Time	(I _F = 10 mA, V _{CC} = 10 V, R _L = 100 Ω)	t _{on}	MCT2		50		
			MCT2E		50		
Turn-off Time	(I _F = 10 mA, V _{CC} = 10 V, R _L = 100 Ω)	t _{off}	MCT2		20		
			MCT2E		20		
Rise Time	(I _F = 10 mA, V _{CC} = 10 V, R _L = 100 Ω)	t _r	MCT2-M MCT2E-M		2		
Fall Time	(I _F = 10 mA, V _{CC} = 10 V, R _L = 100 Ω)	t _f	MCT2-M MCT2E-M		1.5		

** Typical values at $T_A = 25^\circ\text{C}$

勝特力材料 886-3-5753170
勝特力电子(上海) 86-21-54151736
勝特力电子(深圳) 86-755-83298787
[Http://www.100y.com.tw](http://www.100y.com.tw)

**MCT2
MCT2200**

**MCT2E
MCT2201**

**MCT210
MCT2202**

MCT271

TRANSFER CHARACTERISTICS (Cont.)

AC Characteristic	Test Conditions	Symbol	Device	Min	Typ**	Max	Unit
Saturated turn-on time	$(I_F = 16 \text{ mA}, R_L = 1.9 \text{ k}\Omega, V_{CC} = 5 \text{ V})$ (Fig. 20)	t_{on}	MCT271		1.0		μs
Saturated turn-off time (Approximates a typical TTL interface)		t_{off}			48		
Saturated turn-on time	$(I_F = 16 \text{ mA}, R_L = 4.7 \text{ k}\Omega, V_{CC} = 5 \text{ V})$ (Fig. 20)	t_{on}			1.0		
Saturated turn-off time (Approximates a typical low power TTL interface)		t_{off}			98		
Saturated rise time	$(I_F = 16 \text{ mA}, R_L = 560 \Omega, V_{CC} = 5 \text{ V})$ (Fig. 20, 21)	t_r	MCT210		1.0		
Saturated fall time		t_f			11		
Saturated propagation delay - high to low	$(I_F = 16 \text{ mA}, R_L = 2.7 \text{ k}\Omega)$ (Fig. 20, 21)	$T_{PD} \text{ (HL)}$	MCT210		1.0		
Saturated propagation delay - low to high		$T_{PD} \text{ (LH)}$			50		
Non-saturated turn on time	$(I_C = 2 \text{ mA}, V_{CC} = 10 \text{ V}, R_L = 100 \Omega)$ (Fig. 20)	T_{ON}	MCT2200		2	10	
Non-saturated turn off time		T_{OFF}	MCT2201 MCT2202		2	10	
Non-saturated rise time	$(I_C = 2 \text{ mA}, V_{CC} = 5 \text{ V}, R_L = 100 \Omega)$ (Fig. 20)	t_r	MCT210		2		
Non-saturated fall time		t_f			2		
Non-saturated turn-on time	$(I_C = 2 \text{ mA}, V_{CC} = 5 \text{ V}, R_L = 100 \Omega)$ (Fig. 20)	t_{on}	MCT271		2	7	
Non-saturated turn-off time		t_{off}			2	7	

** Typical values at $T_A = 25^\circ\text{C}$

ISOLATION CHARACTERISTICS

Characteristic	Test Conditions	Symbol	Min	Typ*	Max	Units
Input-Output Isolation Voltage	(Non '-M', Black Package) (f = 60 Hz, t = 1 min)	V_{ISO}	5300			Vac(rms)
	('-M', White Package) (f = 60 Hz, t = 1 sec)		7500			Vac(pk)
Isolation Resistance	$(V_{I-O} = 500 \text{ VDC})$	R_{ISO}	10^{11}			Ω
Isolation Capacitance	$(V_{I-O} = \&, f = 1 \text{ MHz})$	C_{ISO}		0.5		pF
	('-M' White Package)			0.2	2	pF

Note

* Typical values at $T_A = 25^\circ\text{C}$

勝特力材料 886-3-5753170
勝特力电子(上海) 86-21-54151736
勝特力电子(深圳) 86-755-83298787
[Http://www.100y.com.tw](http://www.100y.com.tw)

MCT2
MCT2200

MCT2E
MCT2201

MCT210
MCT2202

MCT271

TYPICAL PERFORMANCE CURVES

Fig. 1 LED Forward Voltage vs. Forward Current (Black Package)

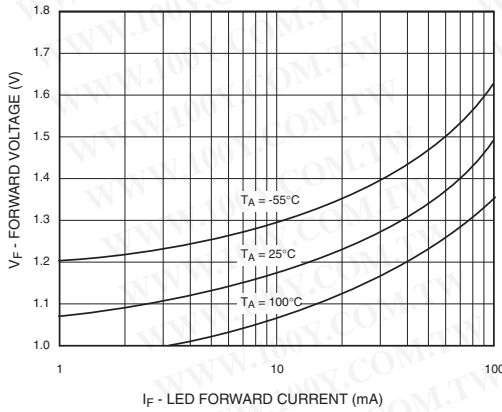

Fig. 2 LED Forward Voltage vs. Forward Current (White Package)

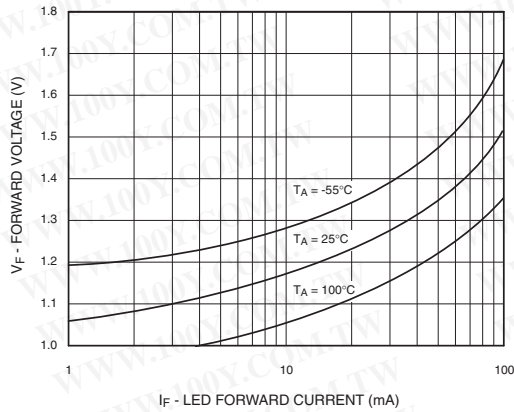

Fig.3 Normalized CTR vs. Forward Current (Black Package)

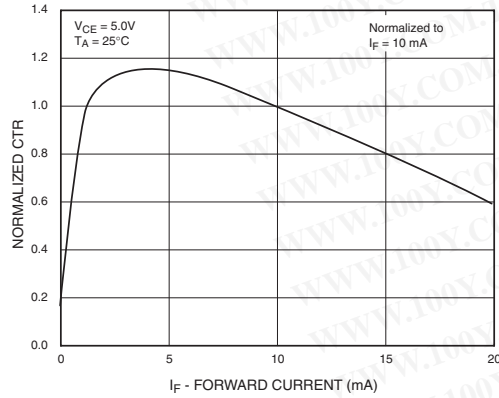

Fig.4 Normalized CTR vs. Forward Current (White Package)

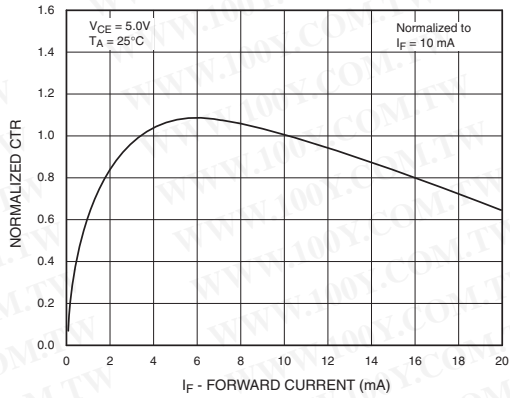

Fig. 5 Normalized CTR vs. Ambient Temperature (Black Package)

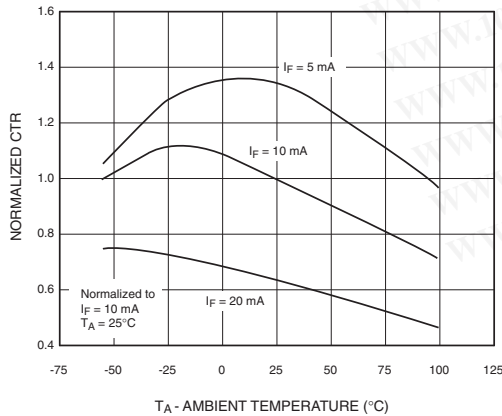
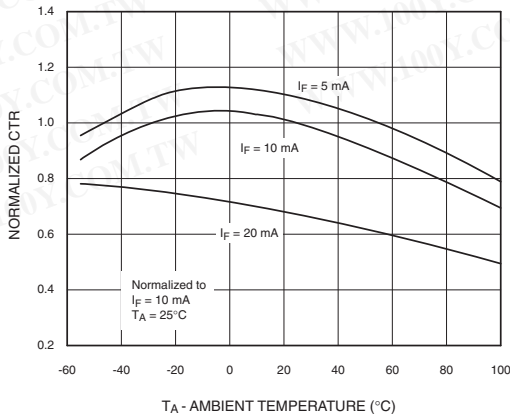

Fig. 6 Normalized CTR vs. Ambient Temperature (White Package)



MCT2
MCT2200

MCT2E
MCT2201

MCT210
MCT2202

MCT271

Fig. 7 CTR vs. RBE (Unsaturated)
(Black Package)

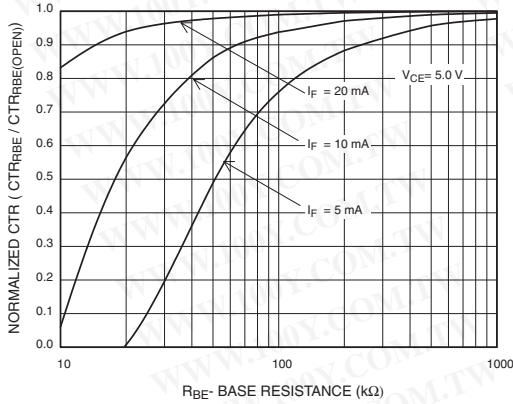

Fig. 8 CTR vs. RBE (Unsaturated)
(White Package)

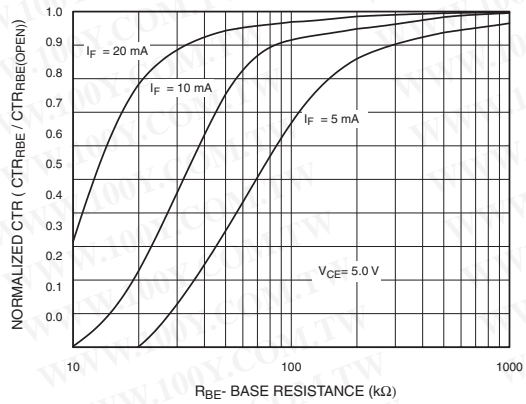

Fig. 9 CTR vs. RBE (Saturated)
(Black Package)

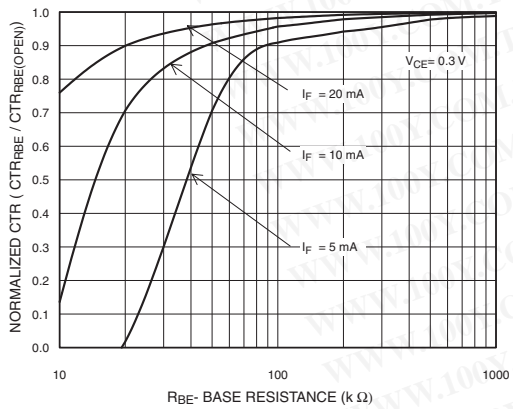

Fig. 10 CTR vs. RBE (Saturated)
(White Package)

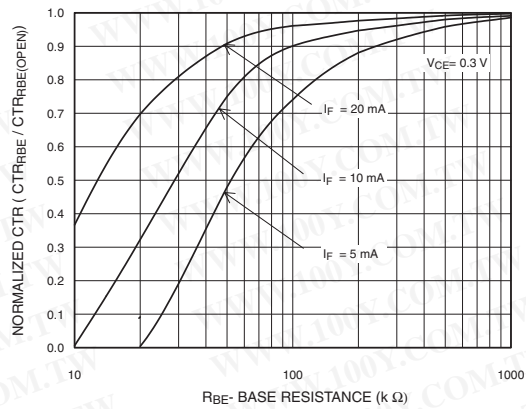

Fig. 11 Collector-Emitter Saturation Voltage vs. Collector Current
(Black Package)

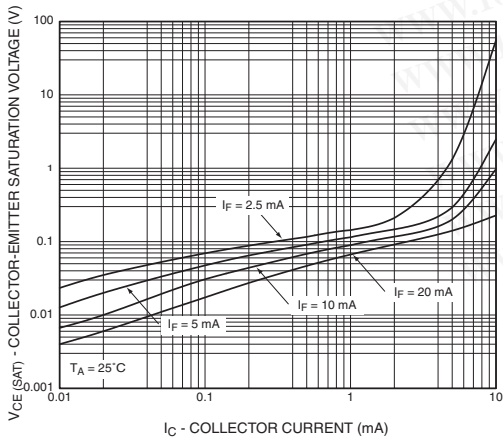
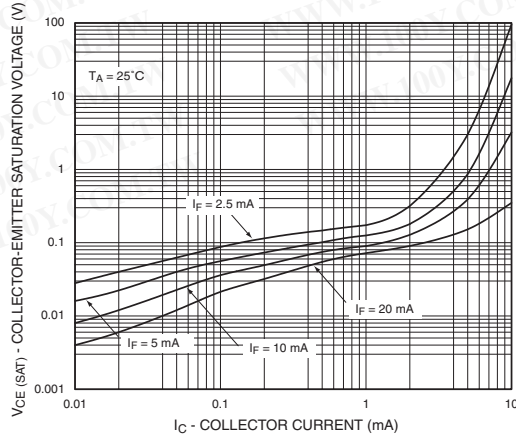

Fig. 12 Collector-Emitter Saturation Voltage vs. Collector Current
(White Package)



MCT2
MCT2200

MCT2E
MCT2201

MCT210
MCT2202

MCT271

Fig. 13 Switching Speed vs. Load Resistor (Black Package)

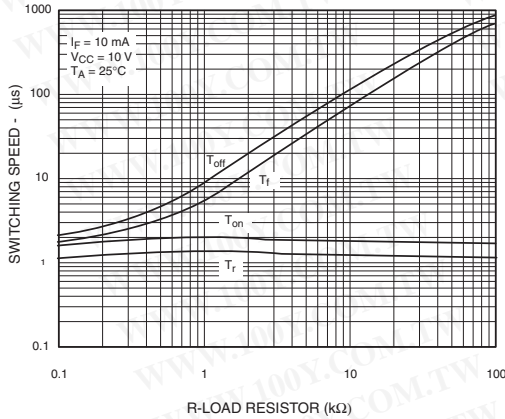

Fig. 14 Switching Speed vs. Load Resistor (White Package)

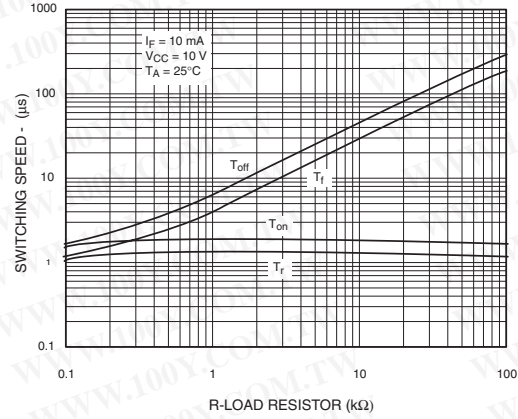

Fig. 15 Normalized t_{on} vs. R_{BE} (Black Package)

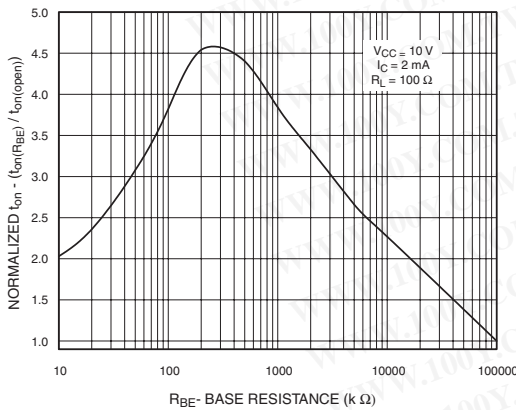

Fig. 16 Normalized t_{on} vs. R_{BE} (White Package)

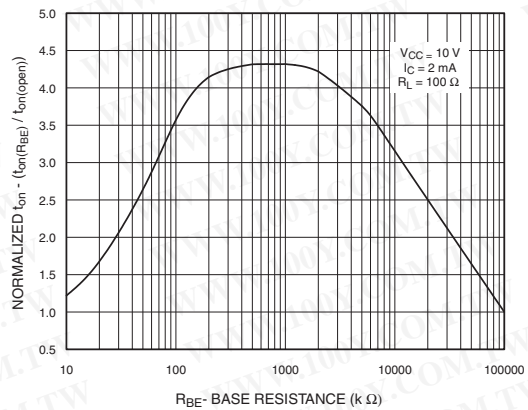

Fig. 17 Normalized t_{off} vs. R_{BE} (Black Package)

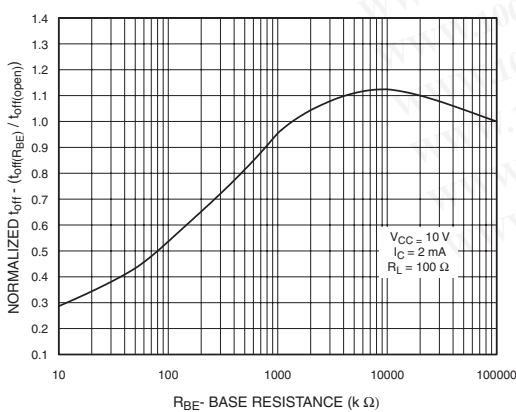
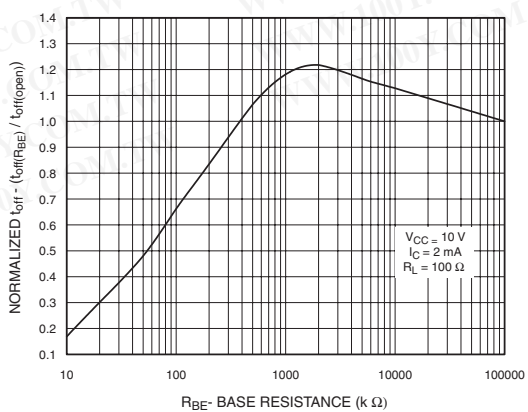

Fig. 18 Normalized t_{off} vs. R_{BE} (White Package)



**MCT2
MCT2200**

**MCT2E
MCT2201**

**MCT210
MCT2202**

MCT271

Fig. 19 Dark Current vs. Ambient Temperature

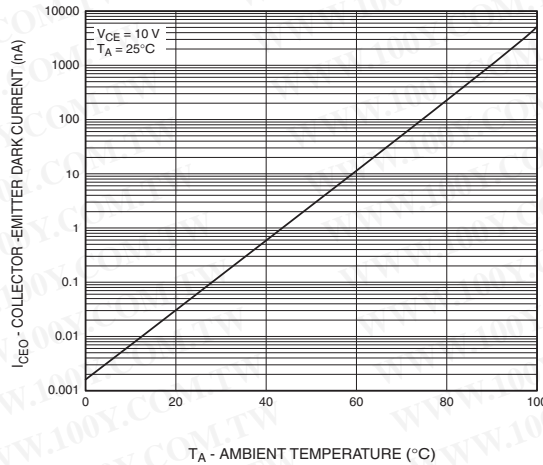

勝特力材料 886-3-5753170
 勝特力电子(上海) 86-21-54151736
 勝特力电子(深圳) 86-755-83298787
[Http://www.100y.com.tw](http://www.100y.com.tw)

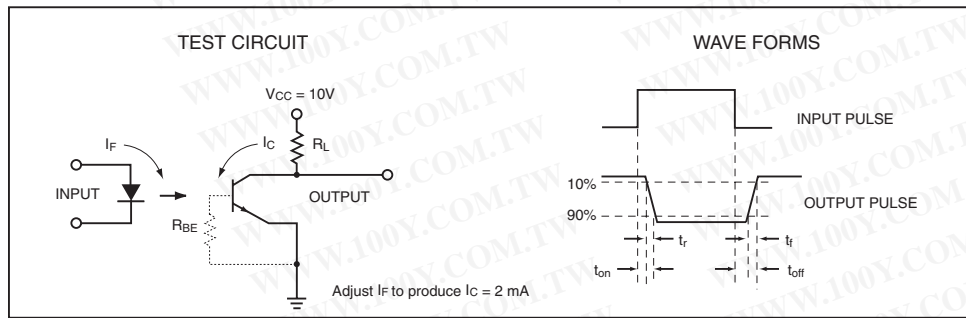

Figure 20. Switching Time Test Circuit and Waveforms

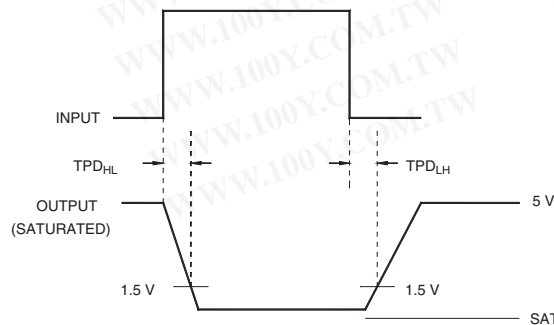

Figure 21. Switching Time Waveforms (MCT210)

**MCT2
MCT2200**

**MCT2E
MCT2201**

**MCT210
MCT2202**

MCT271

Black Package (No -M Suffix)

Package Dimensions (Through Hole)

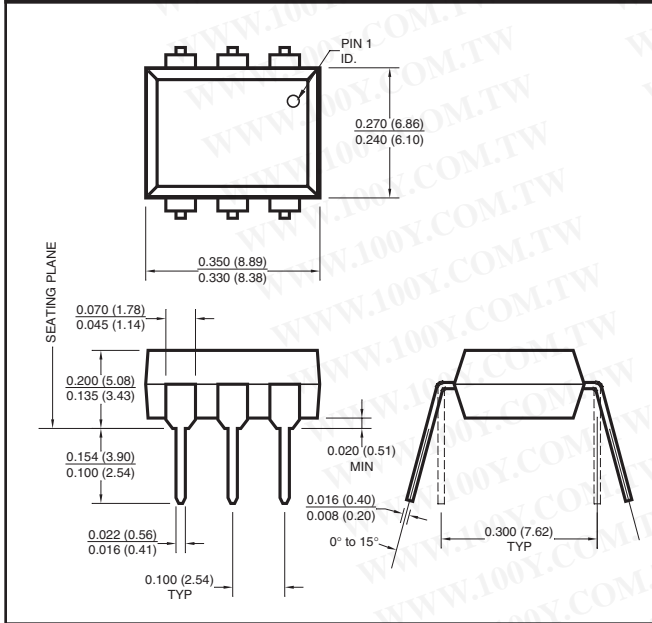

Package Dimensions (Surface Mount)

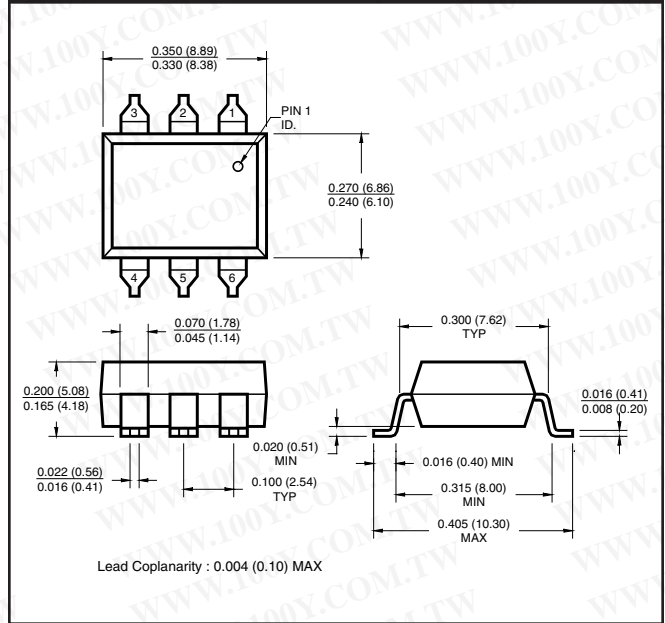

Package Dimensions (0.4" Lead Spacing)

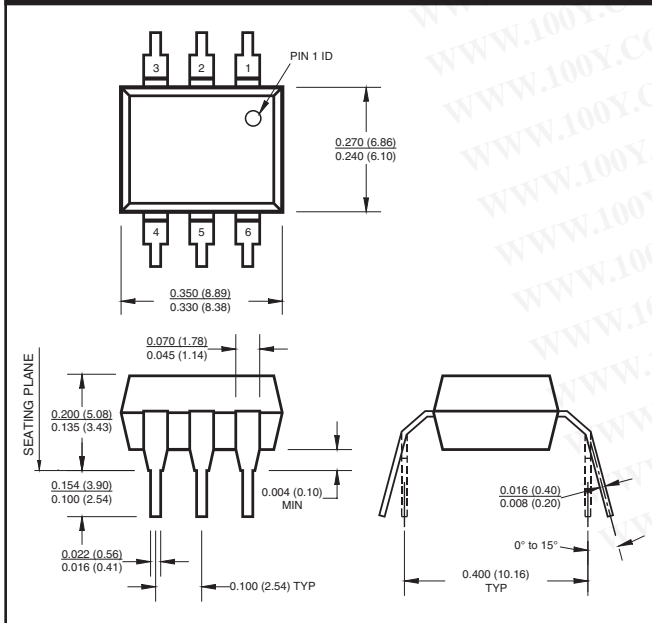

Recommended Pad Layout for Surface Mount Leadform

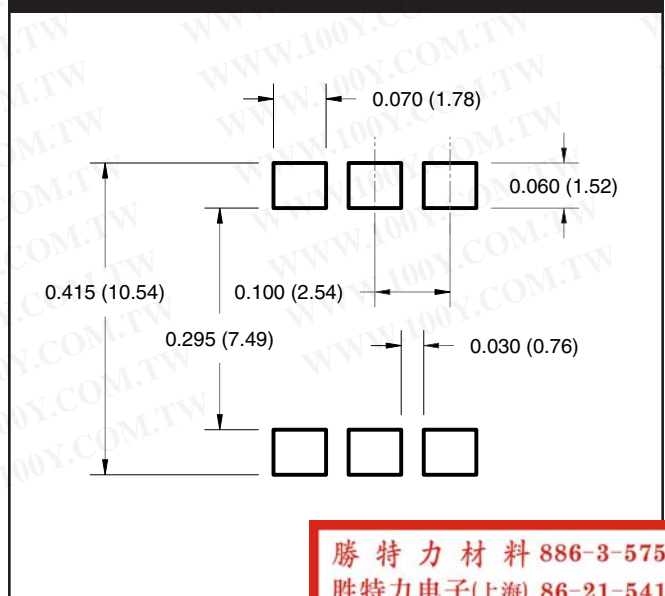

NOTE
All dimensions are in inches (millimeters)

勝特力材料 886-3-5753170
勝特力电子(上海) 86-21-54151736
勝特力电子(深圳) 86-755-83298787
[Http://www.100y.com.tw](http://www.100y.com.tw)

**MCT2
MCT2200**

**MCT2E
MCT2201**

**MCT210
MCT2202**

MCT271

White Package (-M Suffix)

Package Dimensions (Through Hole)

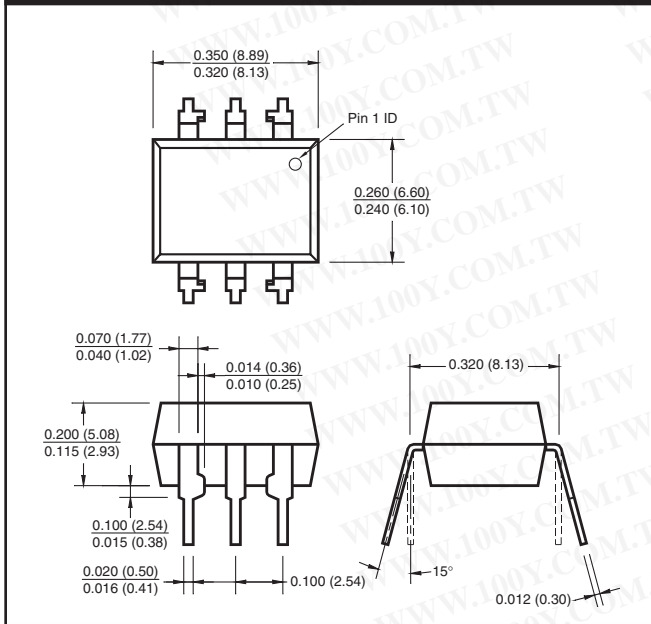

Package Dimensions (Surface Mount)

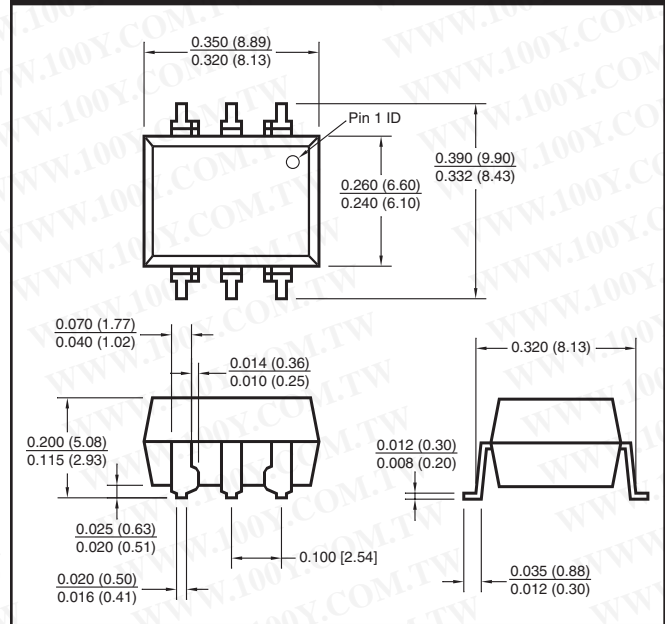

Package Dimensions (0.4" Lead Spacing)

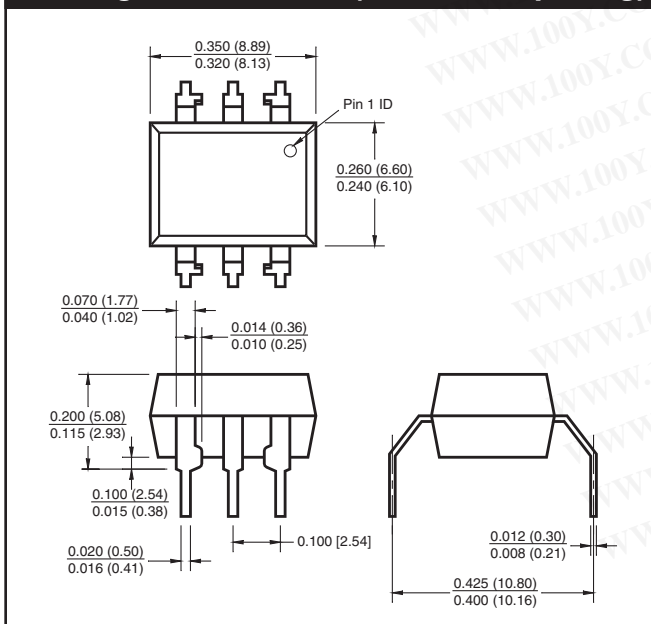

Recommended Pad Layout for Surface Mount Leadform

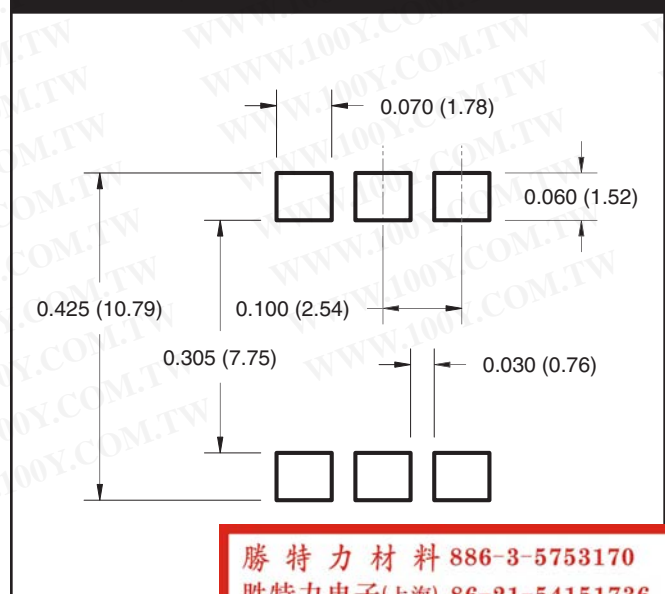

NOTE

All dimensions are in inches (millimeters)

勝特力材料 886-3-5753170
勝特力电子(上海) 86-21-54151736
勝特力电子(深圳) 86-755-83298787
[Http://www.100y.com.tw](http://www.100y.com.tw)

MCT2
MCT2200

MCT2E
MCT2201

MCT210
MCT2202

MCT271

ORDERING INFORMATION

Order Entry Identifier		
Black Package (No Suffix)	White Package (-M Suffix)	Description
.S	S	Surface Mount Lead Bend
.SD	SR2	Surface Mount; Tape and reel
.W	T	0.4" Lead Spacing
.300	V	VDE 0884
.300W	TV	VDE 0884, 0.4" Lead Spacing
.3S	SV	VDE 0884, Surface Mount
.3SD	SR2V	VDE 0884, Surface Mount, Tape & Reel

MARKING INFORMATION

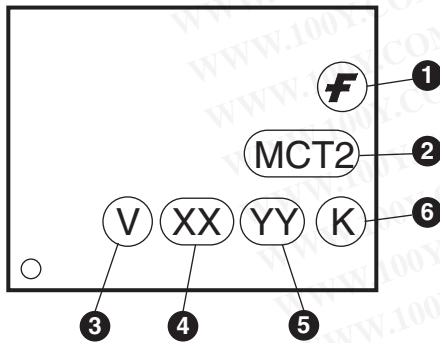

Black Package, No Suffix

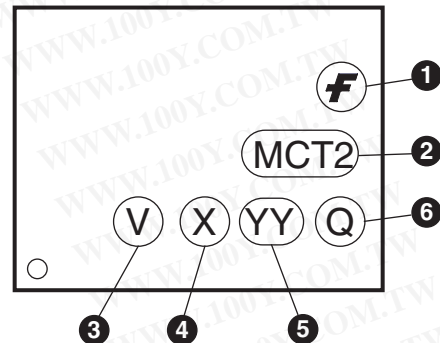

White Package, -M Suffix

Definitions	
1	Fairchild logo
2	Device number
3	VDE mark (Note: Only appears on parts ordered with VDE option – See order entry table)
4	One or two digit year code • Two digits for black package parts, e.g., '03' • One digit for white package parts, e.g., '3'
5	Two digit work week ranging from '01' to '53'
6	Assembly package code

*Note – Parts built in the white package (M suffix) that do not have the 'V' option (see definition 3 above) that are marked with date code '325' or earlier are marked in the portrait format.

勝特力材料 886-3-5753170
 勝特力电子(上海) 86-21-54151736
 勝特力电子(深圳) 86-755-83298787
[Http://www.100y.com.tw](http://www.100y.com.tw)

**MCT2
MCT2200**

**MCT2E
MCT2201**

**MCT210
MCT2202**

MCT271

QT Carrier Tape Specifications ("D" Taping Orientation) (Black Package, No Suffix)

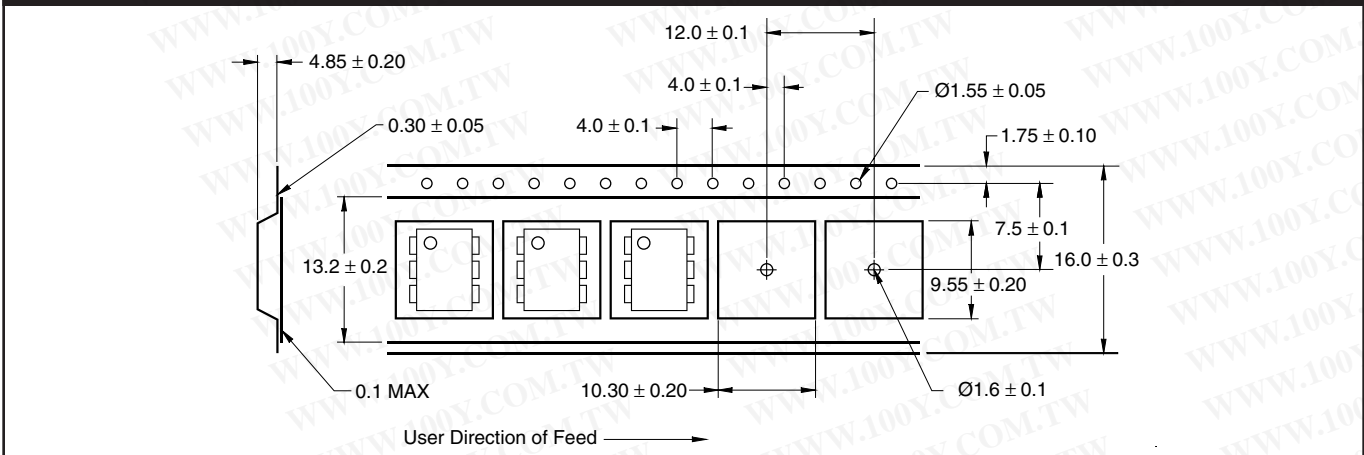

QT Carrier Tape Specifications ("D" Taping Orientation) (White Package, -M Suffix)

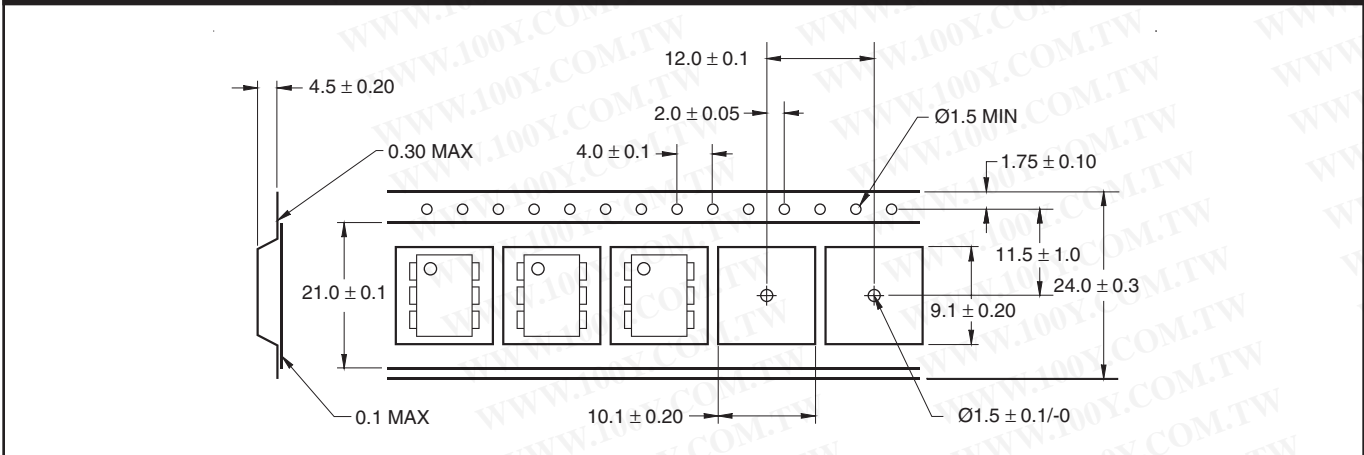

勝特力材料 886-3-5753170
 勝特力电子(上海) 86-21-54151736
 勝特力电子(深圳) 86-755-83298787
[Http://www.100y.com.tw](http://www.100y.com.tw)

MCT2
MCT2200

MCT2E
MCT2201

MCT210
MCT2202

MCT271

Reflow Profile (White Package, -M Suffix)

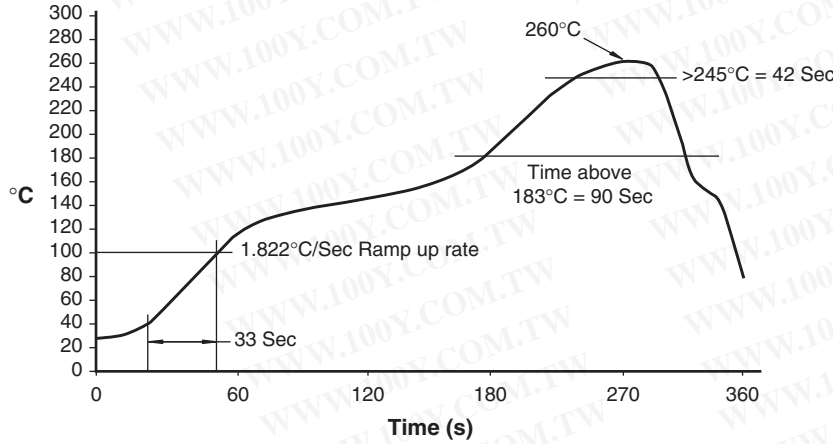

勝特力材料 886-3-5753170
勝特力电子(上海) 86-21-54151736
勝特力电子(深圳) 86-755-83298787
[Http://www.100y.com.tw](http://www.100y.com.tw)

Reflow Profile (Black Package, No Suffix)

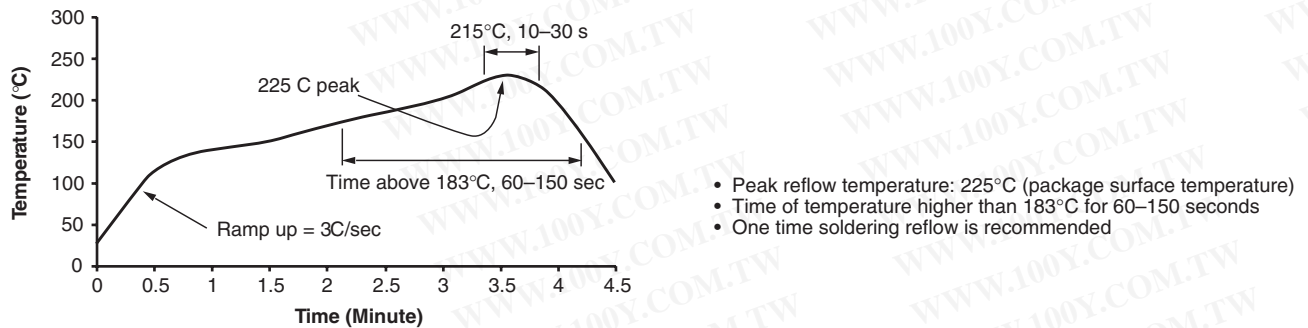

MCT2
MCT2200

MCT2E
MCT2201

MCT210
MCT2202

MCT271

DISCLAIMER

FAIRCHILD SEMICONDUCTOR RESERVES THE RIGHT TO MAKE CHANGES WITHOUT FURTHER NOTICE TO ANY PRODUCTS HEREIN TO IMPROVE RELIABILITY, FUNCTION OR DESIGN. FAIRCHILD DOES NOT ASSUME ANY LIABILITY ARISING OUT OF THE APPLICATION OR USE OF ANY PRODUCT OR CIRCUIT DESCRIBED HEREIN; NEITHER DOES IT CONVEY ANY LICENSE UNDER ITS PATENT RIGHTS, NOR THE RIGHTS OF OTHERS.

LIFE SUPPORT POLICY

FAIRCHILD'S PRODUCTS ARE NOT AUTHORIZED FOR USE AS CRITICAL COMPONENTS IN LIFE SUPPORT DEVICES OR SYSTEMS WITHOUT THE EXPRESS WRITTEN APPROVAL OF THE PRESIDENT OF FAIRCHILD SEMICONDUCTOR CORPORATION. As used herein:

1. Life support devices or systems are devices or systems which, (a) are intended for surgical implant into the body, or (b) support or sustain life, and (c) whose failure to perform when properly used in accordance with instructions for use provided in the labeling, can be reasonably expected to result in a significant injury of the user.
2. A critical component in any component of a life support device or system whose failure to perform can be reasonably expected to cause the failure of the life support device or system, or to affect its safety or effectiveness.

勝特力材料 886-3-5753170
勝特力电子(上海) 86-21-54151736
勝特力电子(深圳) 86-755-83298787
[Http://www.100y.com.tw](http://www.100y.com.tw)