

H11AA814 SERIES

H11A817 SERIES

PACKAGE

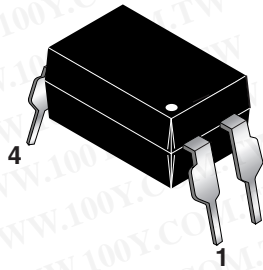

H11AA814 SCHEMATIC

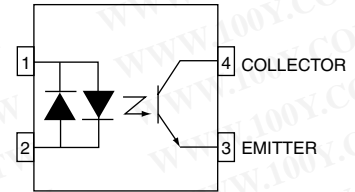

DESCRIPTION

The H11AA814 Series consists of two gallium arsenide infrared emitting diodes, connected in inverse parallel, driving a single silicon phototransistor in a 4-pin dual in-line package.

The H11A817 Series consists of a gallium arsenide infrared emitting diode driving a silicon phototransistor in a 4-pin dual in-line package.

FEATURES

- Compact 4-pin package
- Current transfer ratio in selected groups:

H11AA814:	20-300%	H11A817:	50-600%
H11AA814A:	50-150%	H11A817A:	80-160%
		H11A817B:	130-260%
		H11A817C:	200-400%
		H11A817D:	300-600%

APPLICATIONS

H11AA814 Series

- AC line monitor
- Unknown polarity DC sensor
- Telephone line interface

H11A817 Series

- Power supply regulators
- Digital logic inputs
- Microprocessor inputs

H11A817 SCHEMATIC

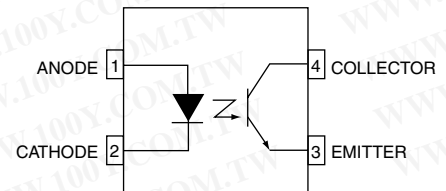

H11AA814 SERIES

H11A817 SERIES

Parameter	Symbol	Device	Value	Units
TOTAL DEVICE				
Storage Temperature	T _{STG}	All	-55 to +150	°C
Operating Temperature	T _{OPR}	All	-55 to +100	°C
Lead Solder Temperature	T _{SOL}	All	260 for 10 sec	°C
Total Device Power Dissipation (-55°C to 50 °C)	P _D	All	200	mW
EMITTER				
Continuous Forward Current	I _F	All	50	mA
Reverse Voltage	V _R	H11A817, H11A817A, H11A817B, H11A817C, H11A817C, H11A817D	5	V
Forward Current - Peak (1 μs pulse, 300 pps)	I _{F(pk)}	All	1.0	A
LED Power Dissipation (25°C ambient) Derate above 25°C	P _D	All	100	mW
			1.33	mW/°C
DETECTOR				
Collector-Emitter Voltage	V _{CEO}	All	35	V
Emitter-Collector Voltage	V _{ECO}	All	6	V
Continuous Collector Current	I _C	All	50	mA
Detector Power Dissipation (25°C ambient) Derate above 25°C	P _D	All	150	mW
			2.0	mW/°C

ELECTRICAL CHARACTERISTICS (T_A = 25°C Unless otherwise specified.)

INDIVIDUAL COMPONENT CHARACTERISTICS

Parameter	Test Conditions	Symbol	Device	Min	Typ	Max	Unit
EMITTER Input Forward Voltage	(I _F = 20 mA)	V _F	H11A817, H11A17A, H11A817B, H11A817C, H11A817D		1.2	1.5	V
	(I _F = ±20 mA)			H11AA814		1.2	
REVERSE LEAKAGE CURRENT Reverse Leakage Current	(V _R = 5.0 V)	I _R	H11A817, H11A17A,		.001	10	μA
			H11A817B, H11A817C,				
			H11A817D				
DETECTOR							
Collector-Emitter Breakdown Voltage	(I _C = 1.0 mA, I _F = 0)	BV _{CEO}	ALL	35	100		V
Emitter-Collector Breakdown Voltage	(I _E = 100 μA, I _F = 0)	BV _{ECO}	ALL	6	10		V
Collector-Emitter Dark Current	(V _{CE} = 10V, I _F = 0)	I _{CEO}	ALL		.025	100	nA
Collector-Emitter Capacitance	(V _{CE} = 0 V, f = 1 MHz)	C _{CE}	ALL		8		pF

H11AA814 SERIES

H11A817 SERIES

TRANSFER CHARACTERISTICS ($T_A = 25^\circ\text{C}$ Unless otherwise specified.)

DC Characteristic	Test Conditions	Symbol	Device	Min	Typ	Max	Unit
Current Transfer Ratio	($I_F = \pm 1 \text{ mA}$, $V_{CE} = 5 \text{ V}$) (note 1)	CTR	H11AA814	20		300	%
	($I_F = \pm 1 \text{ mA}$, $V_{CE} = 5 \text{ V}$) (note 1)	CTR	H11AA814A	50		150	%
	($I_F = 5 \text{ mA}$, $V_{CE} = 5 \text{ V}$) (note 1)	CTR	H11A817	50		600	%
			H11A817A	80		160	%
			H11A817B	130		260	%
			H11A817C	200		400	%
H11A817D	300		600	%			
Collector-Emitter Saturation Voltage	($I_C = 1 \text{ mA}$, $I_F = \pm 20 \text{ mA}$)	$V_{CE(SAT)}$	ALL		.1	.2	V
AC Characteristic							
Rise Time	($I_C = 2 \text{ mA}$, $V_{CE} = 2 \text{ V}$, $R_L = 100\Omega$) (note 1)	T_R	ALL		2.4	18	μs
Fall Time	($I_C = 2 \text{ mA}$, $V_{CE} = 2 \text{ V}$, $R_L = 100\Omega$) (note 1)	T_F	ALL		2.4	18	μs

ISOLATION CHARACTERISTICS

Characteristic	Test Conditions	Symbol	Min	Typ	Max	Units
Input-Output Isolation Voltage (note 3)	($I_{I-O} [1 \mu\text{A}$, 1 min.)	V_{ISO}	5300			Vac(rms)
Isolation Resistance	($V_{I-O} = 500 \text{ VDC}$)	R_{ISO}	10^{11}			Ω
Isolation Capacitance	($V_{I-O} = \&$, $f = 1 \text{ MHz}$)	C_{ISO}		0.5		pf

NOTES

1. Current Transfer Ratio (CTR) = $I_C/I_F \times 100\%$.
2. For test circuit setup and waveforms, refer to Figure 8.
3. For this test, Pins 1 and 2 are common, and Pins 4, 5 and 6 are common.

H11AA814 SERIES

H11A817 SERIES

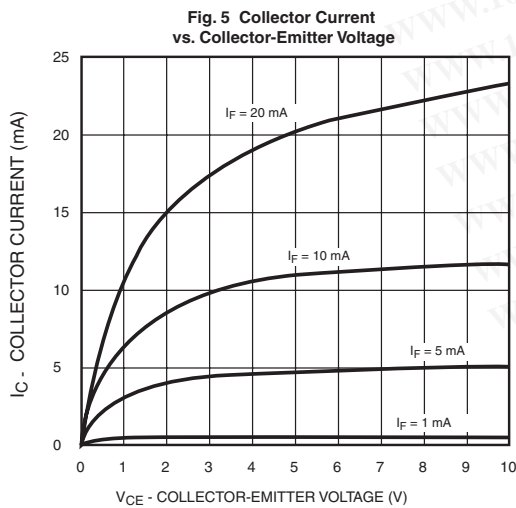
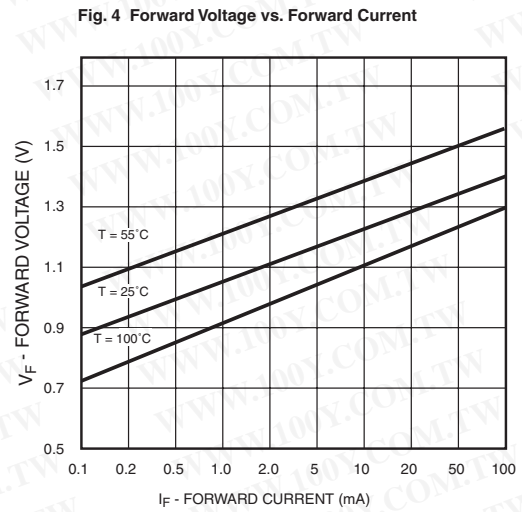
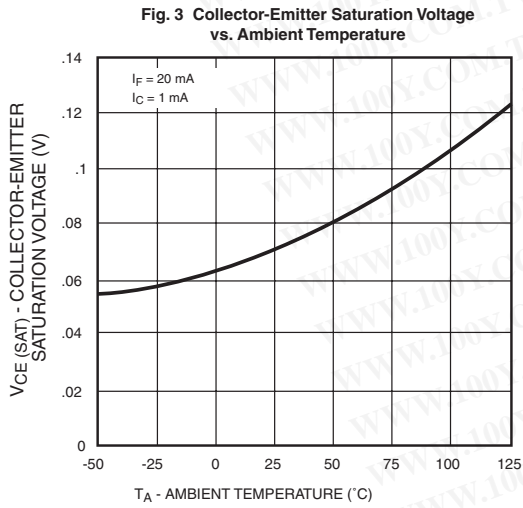
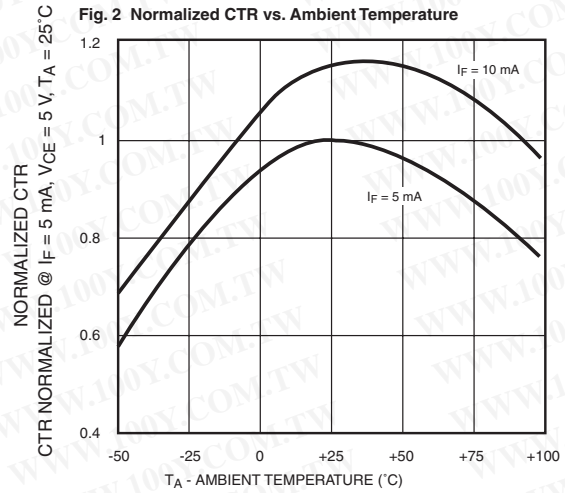
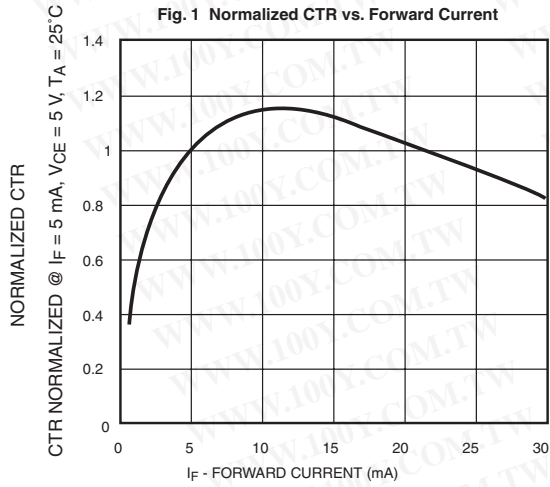

H11AA814 SERIES

H11A817 SERIES

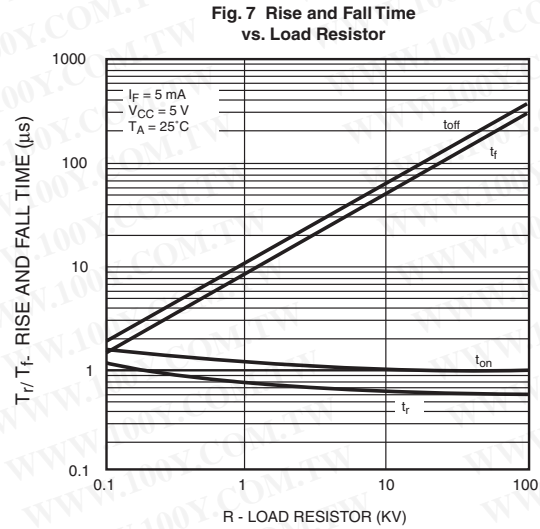
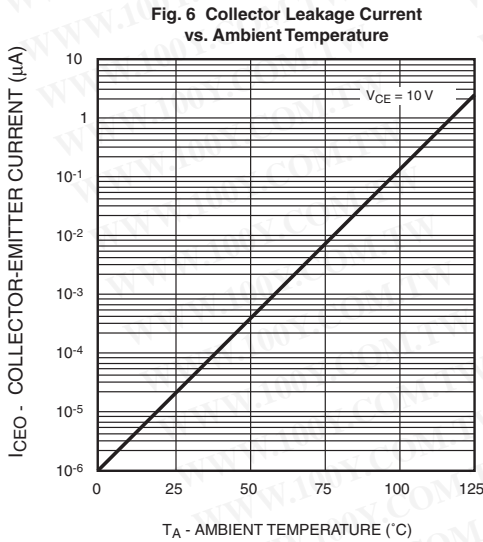
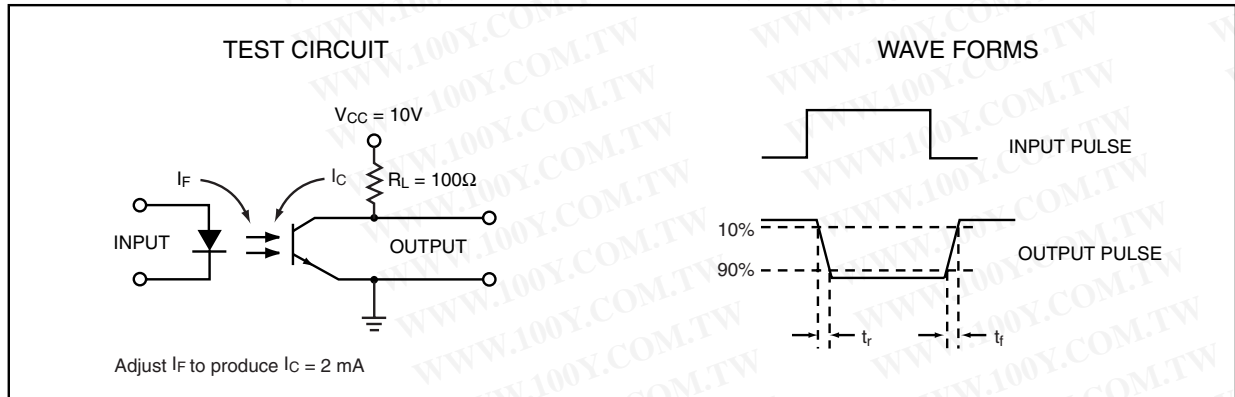
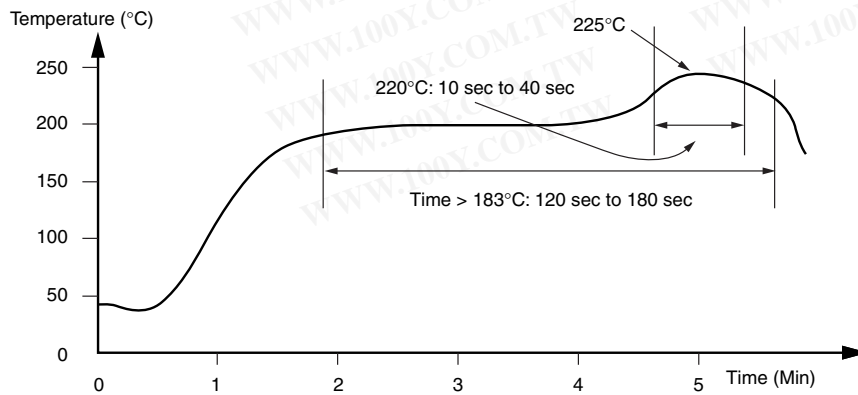

Figure 8. Switching Time Test Circuit and Waveforms



Recommended Thermal Reflow Profile for Surface Mount DIP Package



H11AA814 SERIES

H11A817 SERIES

Package Dimensions (Through Hole)

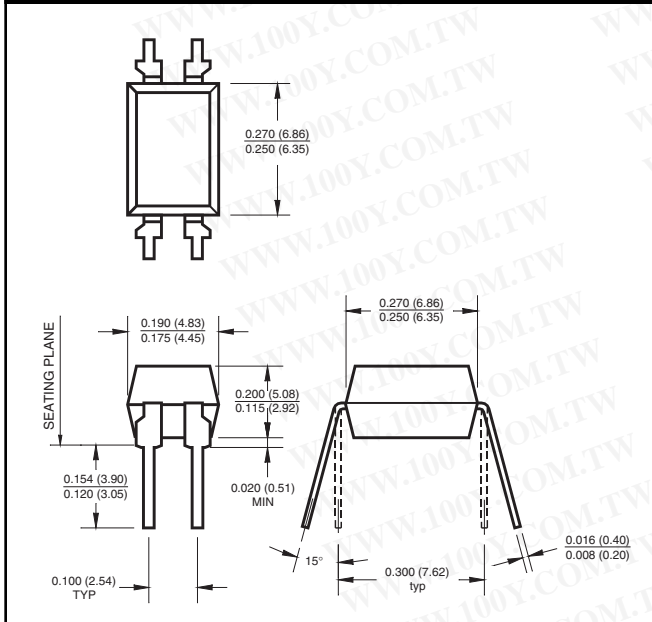

Package Dimensions (Surface Mount)

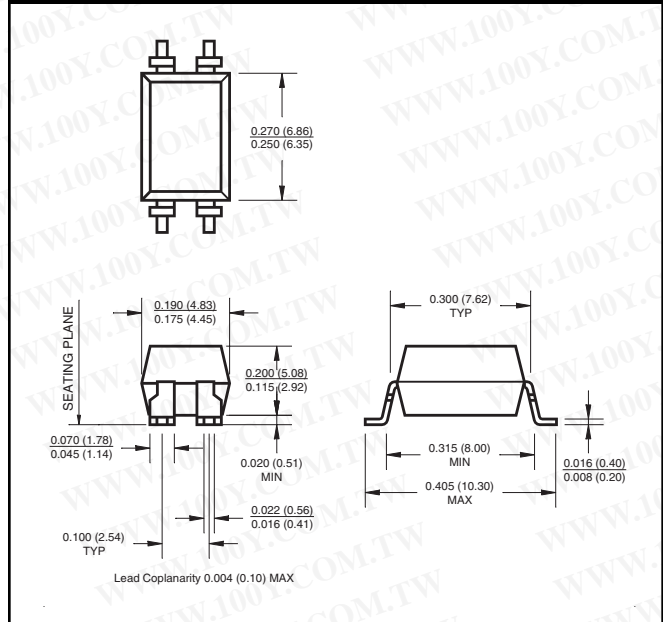

Package Dimensions (0.4" Lead Spacing)

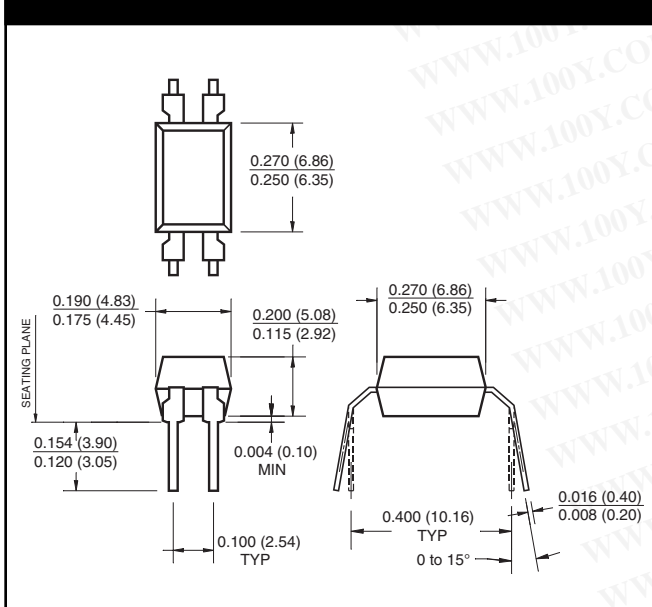

Footprint Dimensions (Surface Mount)

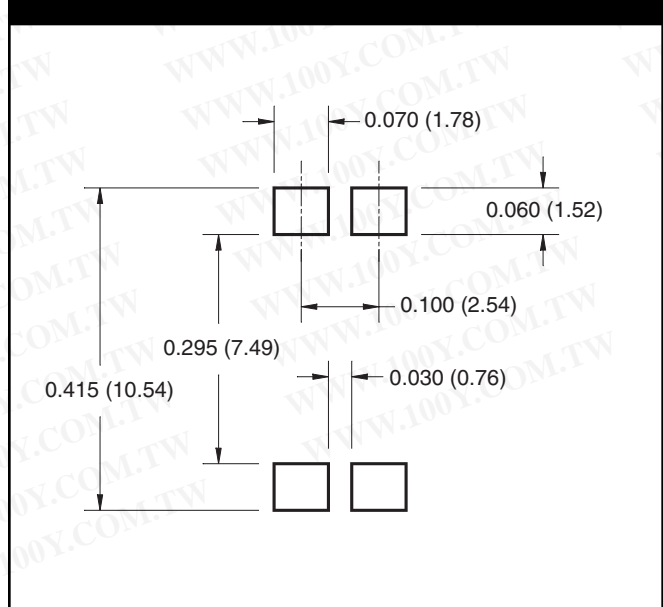

NOTE

All dimensions are in inches (millimeters)

勝特力材料 886-3-5753170
 勝特力电子(上海) 86-21-54151736
 勝特力电子(深圳) 86-755-83298787
[Http://www.100y.com.tw](http://www.100y.com.tw)

H11AA814 SERIES

H11A817 SERIES

ORDERING INFORMATION

Option	Order Entry Identifier	Description
S	.S	Surface Mount Lead Bend
SD	.SD	Surface Mount; Tape and reel
W	.W	0.4" Lead Spacing
300	.300	VDE 0884
300W	.300W	VDE 0884, 0.4" Lead Spacing
3S	.3S	VDE 0884, Surface Mount
3SD	.3SD	VDE 0884, Surface Mount, Tape & Reel

Carrier Tape Specifications

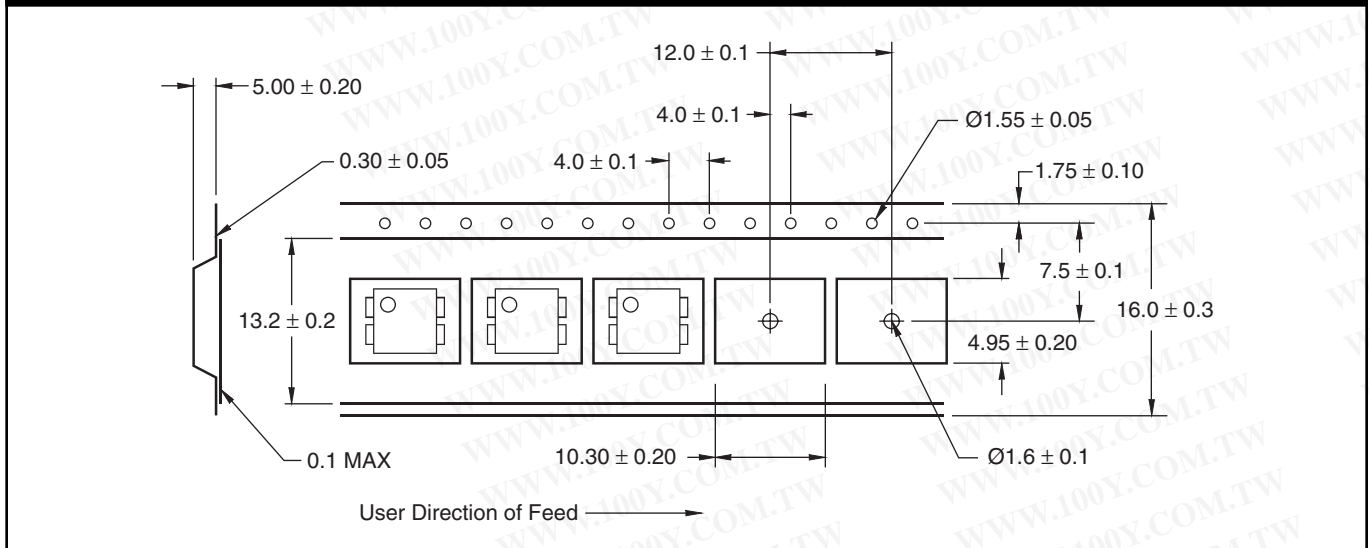

NOTE

All dimensions are in millimeters

H11AA814 SERIES

H11A817 SERIES

DISCLAIMER

FAIRCHILD SEMICONDUCTOR RESERVES THE RIGHT TO MAKE CHANGES WITHOUT FURTHER NOTICE TO ANY PRODUCTS HEREIN TO IMPROVE RELIABILITY, FUNCTION OR DESIGN. FAIRCHILD DOES NOT ASSUME ANY LIABILITY ARISING OUT OF THE APPLICATION OR USE OF ANY PRODUCT OR CIRCUIT DESCRIBED HEREIN; NEITHER DOES IT CONVEY ANY LICENSE UNDER ITS PATENT RIGHTS, NOR THE RIGHTS OF OTHERS.

LIFE SUPPORT POLICY

FAIRCHILD'S PRODUCTS ARE NOT AUTHORIZED FOR USE AS CRITICAL COMPONENTS IN LIFE SUPPORT DEVICES OR SYSTEMS WITHOUT THE EXPRESS WRITTEN APPROVAL OF THE PRESIDENT OF FAIRCHILD SEMICONDUCTOR CORPORATION. As used herein:

1. Life support devices or systems are devices or systems which, (a) are intended for surgical implant into the body, or (b) support or sustain life, and (c) whose failure to perform when properly used in accordance with instructions for use provided in the labeling, can be reasonably expected to result in a significant injury of the user.
2. A critical component in any component of a life support device or system whose failure to perform can be reasonably expected to cause the failure of the life support device or system, or to affect its safety or effectiveness.