

8 MBd Low Input Current Optocoupler

Technical Data

HCPL-2300/HCPL-0300

Features

- **Guaranteed Low Thresholds:**
 $I_F = 0.5 \text{ mA}$, $V_F \leq 1.5 \text{ V}$
- **High Speed: Guaranteed 5 MBd over Temperature**
- **Versatile: Compatible with TTL, LSTTL and CMOS**
- **Efficient 820 nm AlGaAs LED**
- **Internal Shield for Guaranteed Common Mode Rejection**
- **Schottky Clamped, Open Collector Output with Optional Integrated Pull-Up Resistor**
- **Static and Dynamic Performance Guaranteed from -40°C to 85°C**
- **Safety Approval**
 UL Recognized -3750 V rms for 1 minute
 CSA Approved
 IEC/EN/DIN EN 60747-5-2
 Approved with $V_{IORM} = 630 \text{ V}_{\text{peak}}$
 (Option 060)

- **Microprocessor System Interfaces**
- **Digital Isolation for A/D, D/A Conversion**
- **RS-232-C Interface**
- **High Speed, Long Distance Isolated Line Receiver**

Description

The HCPL-2300/HCPL-0300 optocoupler combines an 820 nm AlGaAs photon emitting diode with an integrated high gain photon detector. This

combination of Agilent designed and manufactured semiconductor devices brings new high performance capabilities to designers of isolated logic and data communication circuits.

The new low current, high speed AlGaAs emitter manufactured with a unique diffused junction, has the virtue of fast rise and fall times at low drive currents. Figure 6 illustrates the propagation delay vs. input current characteristic. These unique

Functional Diagram

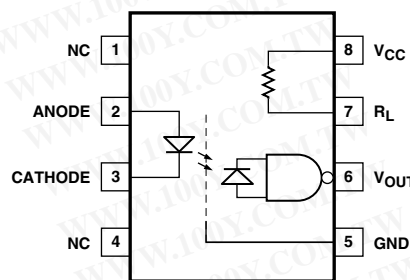

Schematic

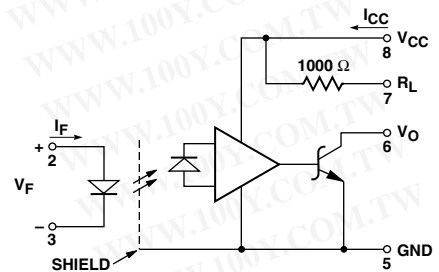

A 0.1 μF CAPACITOR MUST BE CONNECTED BETWEEN PINS 8 AND 5 (SEE NOTE 1).

TRUTH TABLE (POSITIVE LOGIC)

LED	OUTPUT
ON	L
OFF	H

Applications

- **Ground Loop Elimination**
- **Computer-Peripheral Interfaces**
- **Level Shifting**

A 0.1 pF bypass capacitor must be connected between pins 5 and 8.

CAUTION: It is advised that normal static precautions be taken in handling and assembly of this component to prevent damage and/or degradation which may be induced by ESD.

勝特力材料 886-3-5753170
 勝特力电子(上海) 86-21-54151736
 勝特力电子(深圳) 86-755-83298787
 Http://www.100y.com.tw

characteristics enable this device to be used in an RS-232-C interface with ground loop isolation and improved common mode rejection. As a line receiver, the HCPL-2300/HCPL-0300 will operate over longer line lengths for a given data rate because of lower I_F and V_F specifications.

The output of the shielded integrated detector circuit is an open

collector Schottky clamped transistor. The shield, which shunts capacitively coupled common mode noise to ground, provides a guaranteed transient immunity specification of 100 V/ μ s. The output circuit includes an optional integrated 1000 Ω pull-up resistor for the open collector. This gives designers the flexibility to use the internal resistor for pull-up to five volt logic or to use

an external resistor for connection to supply voltages up to 18 V (CMOS logic voltage).

The Electrical and Switching Characteristics of the HCPL-2300/HCPL-0300 are guaranteed over a temperature range of -40°C to 85°C . This enables the user to confidently design a circuit which will operate under a broad range of operating conditions.

Ordering Information

Specify part number followed by Option Number (if desired).

HCPL-2300# XXXX

—	060 = IEC/EN/DIN EN 60747-5-2 $V_{IORM} = 630\text{ V peak}$ Option
—	300 = Gull Wing Surface Mount Lead Option
—	500 = Tape/Reel Package Option (1 K min)
—	XXXE = Lead Free Option

Option data sheets available. Contact your Agilent sales representative or authorized distributor for information.

Remarks: The notation “#” is used for existing products, while (new) products launched since 15th July 2001 and lead free option will use “-”

Package Outline Drawings

Small Outline SO-8 Package HCPL-0300

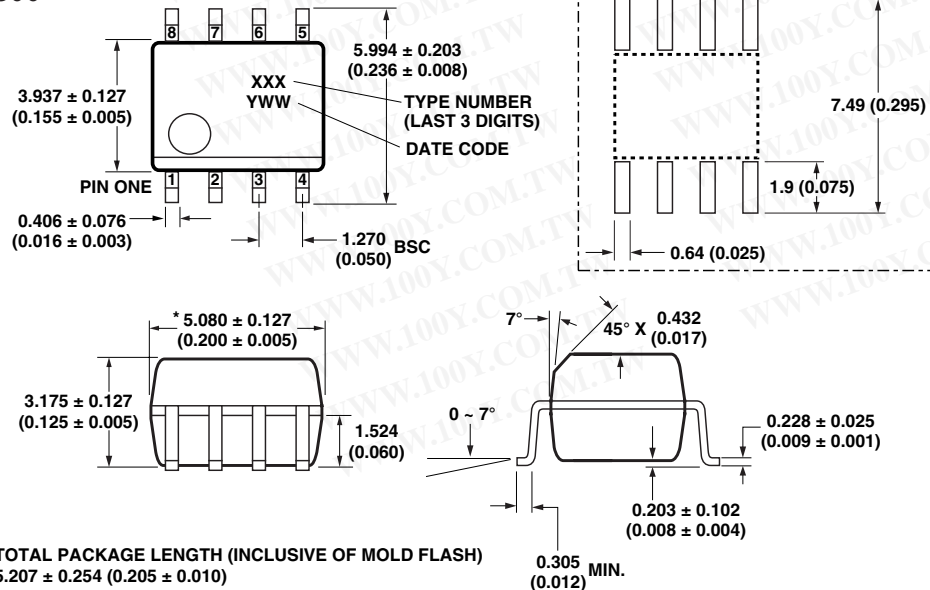

DIMENSIONS IN MILLIMETERS (INCHES).
 LEAD COPLANARITY = 0.10 mm (0.004 INCHES) MAX.

NOTE: FLOATING LEAD PROTRUSION IS 0.15 mm (6 mils) MAX.

勝特力材料 886-3-5753170
 勝特力电子(上海) 86-21-54151736
 勝特力电子(深圳) 86-755-83298787
 Http://www.100y.com.tw

8-Pin DIP Package (HCPL-2300)

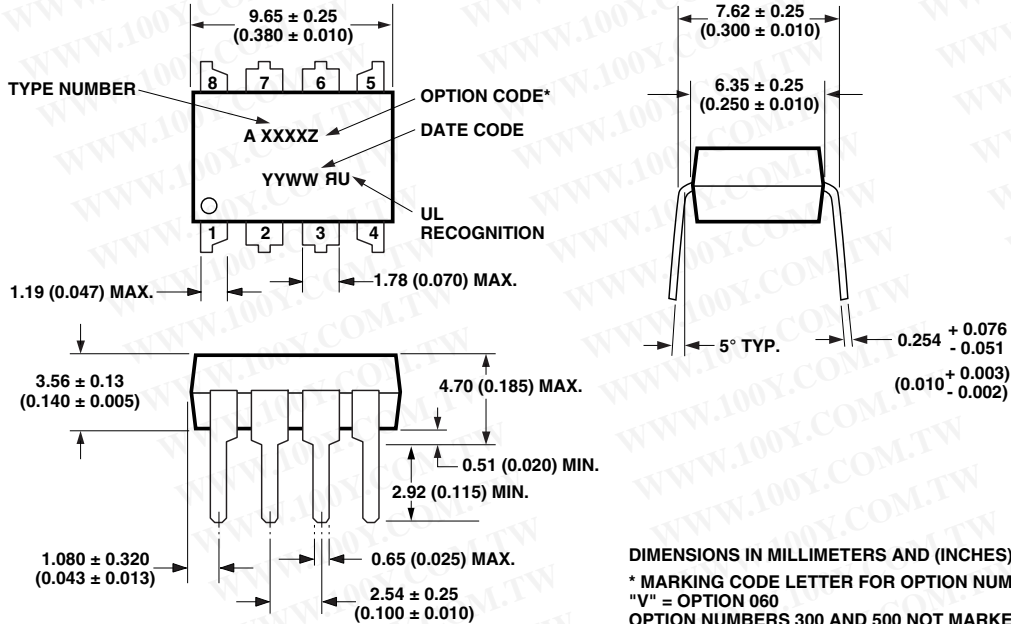

DIMENSIONS IN MILLIMETERS AND (INCHES).

* MARKING CODE LETTER FOR OPTION NUMBERS

"V" = OPTION 060

OPTION NUMBERS 300 AND 500 NOT MARKED.

NOTE: FLOATING LEAD PROTRUSION IS 0.25 mm (10 mils) MAX.

8-Pin DIP Package with Gull Wing Surface Mount Option 300 (HCPL-2300)

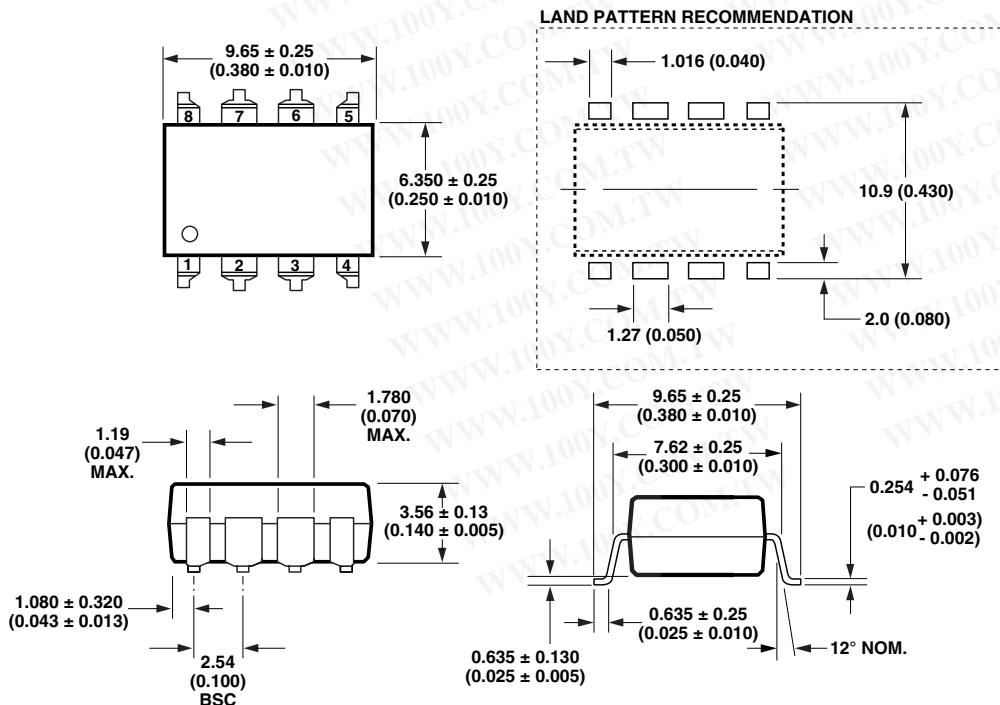

DIMENSIONS IN MILLIMETERS (INCHES).

LEAD COPLANARITY = 0.10 mm (0.004 INCHES).

NOTE: FLOATING LEAD PROTRUSION IS 0.25 mm (10 mils) MAX.

Solder Reflow Temperature Profile

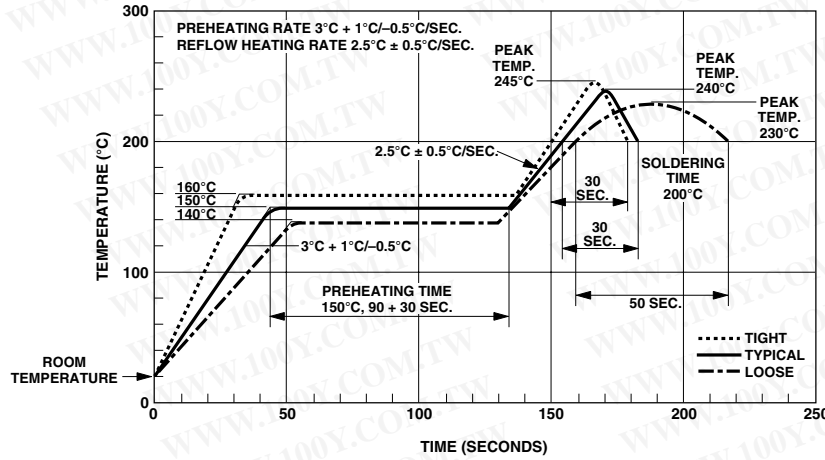

Recommended Pb-Free IR Profile

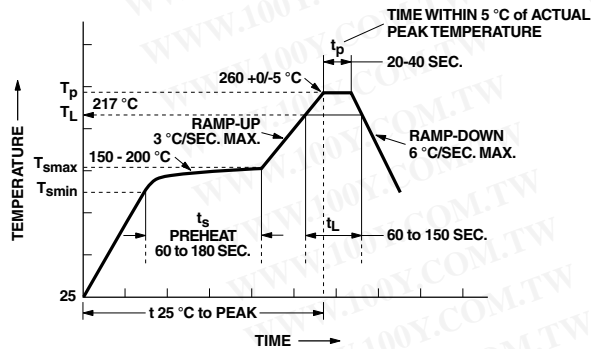

NOTES:
 THE TIME FROM 25 °C to PEAK TEMPERATURE = 8 MINUTES MAX.
 $T_{smax} = 200\text{ °C}$, $T_{smin} = 150\text{ °C}$

Regulatory Information

The HCPL-2300 has been approved by the following organizations:

UL
 Recognized under UL 1577,
 Component Recognition Program,
 File E55361.

CSA
 Approved under CSA Component
 Acceptance Notice #5, File CA 88324.

IEC/EN/DIN EN 60747-5-2

Approved under:
 IEC 60747-5-2:1997 + A1:2002
 EN 60747-5-2:2001 + A1:2002
 DIN EN 60747-5-2 (VDE 0884
 Teil 2):2003-01
 (Option 060 only)

Insulation and Safety Related Specifications

Parameter	Symbol	Value	Units	Conditions
Min. External Air Gap (External Clearance)	L(IO1)	7.1	mm	Measured from input terminals to output terminals, shortest distance through air
Min. External Tracking Path (External Creepage)	L(IO2)	7.4	mm	Measured from input terminals to output terminals, shortest distance path along body
Min. Internal Plastic Gap (Internal Clearance)		0.08	mm	Through insulation distance, conductor to conductor, usually the direct distance between the photoemitter and photodetector inside the optocoupler cavity
Tracking Resistance (Comparative Tracking Index)	CTI	200	Volts	DIN IEC 112/VDE 0303 PART 1
Isolation Group		IIIa		Material Group (DIN VDE 0110, 1/89, Table 1)

Option 300 – surface mount classification is Class A in accordance with CECC 00802.

IEC/EN/DIN EN 60747-5-2 Insulation Related Characteristics (HCPL-2300 Option 060 only)

Description	Symbol	Characteristic	Units
Installation classification per DIN VDE 0110/1.89, Table 1 for rated mains voltage ≤ 300 V rms for rated mains voltage ≤ 450 V rms		I-IV	
		I-III	
		55/85/21	
Climatic Classification		55/85/21	
Pollution Degree (DIN VDE 0110/1.89)		2	
Maximum Working Insulation Voltage	V _{IORM}	630	V _{peak}
Input to Output Test Voltage, Method b* V _{IORM} × 1.875 = V _{PR} , 100% Production Test with t _m = 1 sec, Partial Discharge < 5 pC	V _{PR}	1181	V _{peak}
Input to Output Test Voltage, Method a* V _{IORM} × 1.5 = V _{PR} , Type and sample test, t _m = 60 sec, Partial Discharge < 5 pC	V _{PR}	945	V _{peak}
Highest Allowable Overvoltage* (Transient Overvoltage, t _{ini} = 10 sec)	V _{IOTM}	6000	V _{peak}
Safety Limiting Values (Maximum values allowed in the event of a failure, also see Figure 11, Thermal Derating curve.) Case Temperature Input Current Output Power	T _S I _{S,INPUT} P _{S,OUTPUT}	175 230 600	°C mA mW
Insulation Resistance at T _S , V _{IO} = 500 V	R _S	≥ 10 ⁹	Ω

*Refer to the front of the optocoupler section of the current catalog, under Product Safety Regulations section, IEC/EN/DIN EN 60747-5-2, for a detailed description.

Note: Isolation characteristics are guaranteed only within the safety maximum ratings which must be ensured by protective circuits in application.

Absolute Maximum Ratings

(No Derating Required up to 55°C)

- Storage Temperature, T_S -55°C to +125°C
- Operating Temperature, T_A -40°C to +85°C
- Lead Solder Temperature, max 260°C for 10 s
(1.6 mm below seating plane)
- Average Forward Input Current - I_F 5 mA^[2]
- Reverse Input Voltage, V_R 3.0 V
- Supply Voltage, V_{CC} 0 V to 7.0 V
- Pull-Up Resistor Voltage, V_{RL} -0.5 V to V_{CC}
- Output Collector Current, I_O -25 to 25 mA
- Input Power Dissipation, P_I 10 mW
- Output Collector Power Dissipation, P_O 40 mW
- Output Collector Voltage, V_O -0.5 V to 18 V
- Infrared and Vapor Phase Reflow Temperature
(Option #300) see Fig. 1, Thermal Profile

Recommended Operating Conditions

Parameter	Symbol	Min.	Max.	Units
Input Voltage, Low Level	V _{FL}	-2.5	0.8	V
Input Current High Level	I _{FH}	0°C to 85°C	0.5	1.0
		-40°C to 85°C	0.5	0.75
Supply Voltage, Output	V _{CC}	4.75	5.25	V
Fan Out (TTL Load)	N		5	
Operating Temperature	T _A	-40	85	°C

勝特力材料 886-3-5753170
 勝特力电子(上海) 86-21-54151736
 勝特力电子(深圳) 86-755-83298787
[Http://www.100y.com.tw](http://www.100y.com.tw)

DC Electrical Specifications

For $-40^{\circ}\text{C} \leq T_A \leq 85^{\circ}\text{C}$, $4.75\text{ V} \leq V_{CC} \leq 5.25\text{ V}$, $V_{FL} \leq 0.8\text{ V}$, unless otherwise specified.

All typicals at $T_A = 25^{\circ}\text{C}$ and $V_{CC} = 5\text{ V}$, unless otherwise specified. See note 1.

Parameter	Symbol	Min.	Typ.	Max.	Units	Test Conditions	Fig.	Note
High Level Output Current	I_{OH}		0.05	250	μA	$V_F = 0.8\text{ V}$, $V_O = 18\text{ V}$	4	
Low Level Output Voltage	V_{OL}		0.4	0.5	V	$I_F = 0.5\text{ mA}$ $I_{OL}(\text{Sinking}) = 8\text{ mA}$	3	
High Level Supply Current	I_{CCH}		4.0	6.3	mA	$I_F = 0\text{ mA}$, $V_{CC} = 5.25\text{ V}$		
Low Level Supply Current	I_{CCL}		6.2	10.0	mA	$I_F = 1.0\text{ mA}$, $V_{CC} = 5.25\text{ V}$		
Input Forward Voltage	V_F	1.0	1.3	1.5	V	$T_A = 25^{\circ}\text{C}$ $I_F = 1.0\text{ mA}$	2	
		0.85		1.65				
Input Diode Temperature Coefficient	$\frac{\Delta V_F}{\Delta T_A}$		-1.6		mV/ $^{\circ}\text{C}$	$I_F = 1.0\text{ mA}$		
Input Reverse Breakdown Voltage	BV_R	3.0			V	$I_R = 10\ \mu\text{A}$		
Input Capacitance	C_{IN}		18		pF	$V_F = 0\text{ V}$, $f = 1\text{ MHz}$		
Internal Pull-up Resistor	R_L	680	1000	1700	Ω	$T_A = 25^{\circ}\text{C}$		

Switching Specifications

For $-40^{\circ}\text{C} \leq T_A \leq 85^{\circ}\text{C}$, $0.5\text{ mA} \leq I_{FH} \leq 0.75\text{ mA}$;

For $0^{\circ}\text{C} \leq T_A \leq 85^{\circ}\text{C}$, $0.5\text{ mA} \leq I_{FH} \leq 1.0\text{ mA}$; With $4.75\text{ V} \leq V_{CC} \leq 5.25\text{ V}$, $V_{FL} \leq 0.8\text{ V}$, unless otherwise specified. All typicals at $T_A = 25^{\circ}\text{C}$ and $V_{CC} = 5\text{ V}$, $I_{FH} = 0.625\text{ mA}$, unless otherwise specified. See note 1.

Parameter	Symbol	Min.	Typ.	Max.	Units	Test Conditions	Fig.	Note
Propagation Delay Time to Logic High Output Level	t_{PLH}		95		ns	$C_P = 0\text{ pF}$	5, 6, 8	4, 8
			85	160		$C_P = 20\text{ pF}$	5, 8	
Propagation Delay Time to Logic Low Output Level	t_{PHL}		110		ns	$C_P = 0\text{ pF}$	5, 6, 8	5, 8
			35	200		$C_P = 20\text{ pF}$	5, 8	
Output Rise Time (10-90%)	t_r		40		ns	$C_P = 20\text{ pF}$	7, 8	8
Output Fall Time (90-10%)	t_f		20					
Common Mode Transient Immunity at High Output Level	$ CM_H $	100	400		V/ μs	$V_{CM} = 50\text{ V (peak)}$, $V_O(\text{min.}) = 2\text{ V}$, $R_L = 560\ \Omega$, $I_F = 0\text{ mA}$	9, 10	6
Common Mode Transient Immunity at Low Output Level	$ CM_L $	100	400		V/ μs	$V_{CM} = 50\text{ V (peak)}$, $V_O(\text{max.}) = 0.8\text{ V}$, $R_L = 560\ \Omega$, $I_F = 0.5\text{ mA}$	9, 10	7

勝特力材料 886-3-5753170
 勝特力电子(上海) 86-21-54151736
 勝特力电子(深圳) 86-755-83298787
 Http://www.100y.com.tw

Package Characteristics

For $-40^{\circ}\text{C} \leq T_A \leq 85^{\circ}\text{C}$, unless otherwise specified. All typicals at $T_A = 25^{\circ}\text{C}$.

Parameter	Symbol	Min.	Typ.	Max.	Units	Test Conditions	Fig.	Notes
Input-Output Momentary Withstand Voltage*	V_{ISO}	3750			V rms	RH \leq 50%, t = 1 min, $T_A = 25^{\circ}\text{C}$		3, 9
Resistance, Input-Output	$R_{\text{I-O}}$		10^{12}		Ω	$V_{\text{I-O}} = 500 \text{ V}$		3
Capacitance, Input-Output	$C_{\text{I-O}}$		0.6		pF	f = 1 MHz		3

*The Input-Output Momentary Withstand Voltage is a dielectric voltage rating that should not be interpreted as an input-output continuous voltage rating. For the continuous voltage rating refer to the IEC/EN/DIN EN 60747-5-2 Insulation Characteristics Table (if applicable), your equipment level safety specification, or Agilent Application Note 1074, "Optocoupler Input-Output Endurance Voltage."

Notes:

- By passing the power supply line is required with a 0.1 μF ceramic disc capacitor adjacent to each optocoupler as illustrated in Figure 19. The power supply bus for the optocoupler(s) should be separate from the bus for any active loads, otherwise a larger value of bypass capacitor (up to 0.5 μF) may be needed to suppress regenerative feedback via the power supply.
- Peaking circuits may produce transient input currents up to 100 mA, 500 ns maximum pulse width, provided average current does not exceed 5 mA.
- Device considered a two terminal device: pins 1, 2, 3, and 4 shorted together, and pins 5, 6, 7, and 8 shorted together.
- The t_{PLH} propagation delay is measured from the 50% point on the trailing edge of the input pulse to the 1.5 V point on the trailing edge of the output pulse.
- The t_{PHL} propagation delay is measured from the 50% point on the leading edge of the input pulse to the 1.5 V point on the leading edge of the output pulse.
- CM_H is the maximum tolerable rate of rise of the common mode voltage to assure that the output will remain in a high logic state (i.e., $V_{\text{OUT}} > 2.0 \text{ V}$).
- CM_L is the maximum tolerable rate of fall of the common mode voltage to assure that the output will remain in a low logic state (i.e., $V_{\text{OUT}} < 0.8 \text{ V}$).
- C_P is the peaking capacitance. Refer to test circuit in Figure 8.
- In accordance with UL 1577, each optocoupler is momentary withstand proof tested by applying an insulation test voltage $\geq 4500 \text{ Vrms}$ for 1 second (leakage detection current limit, $I_{\text{I-O}} \leq 5 \mu\text{A}$). This test is performed before the 100% production test for partial discharge (Method b) shown in the IEC/EN/DIN EN 60747-5-2 Insulation Characteristics Table, if applicable.

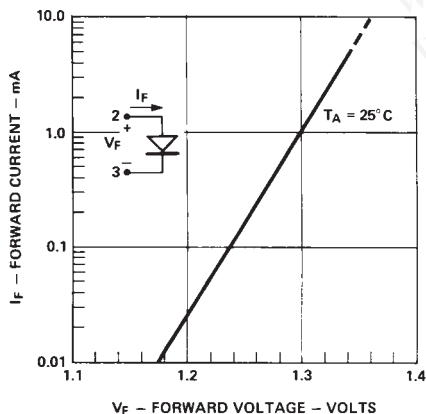

Figure 2. Typical Input Diode Forward Characteristics.

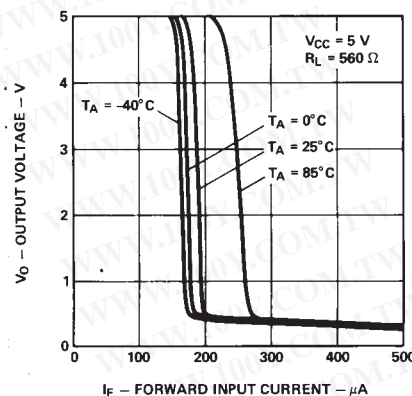

Figure 3. Typical Output Voltage vs. Forward Input Current vs. Temperature.

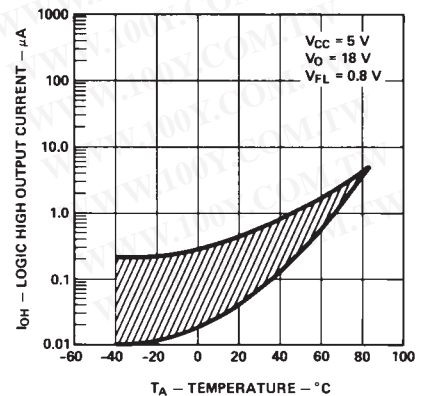

Figure 4. Typical Logic High Output Current vs. Temperature.

勝特力材料 886-3-5753170
勝特力电子(上海) 86-21-54151736
勝特力电子(深圳) 86-755-83298787
Http://www.100y.com.tw

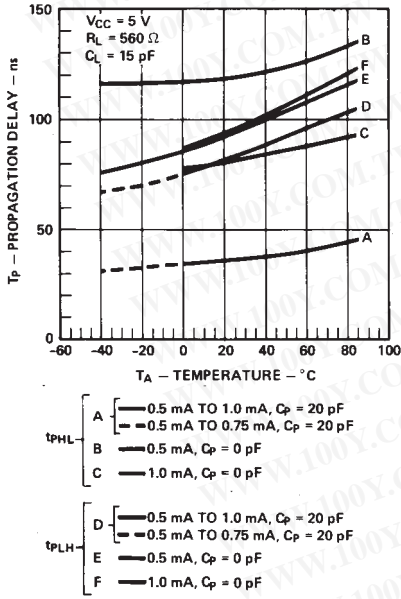

Figure 5. Typical Propagation Delay vs. Temperature and Forward Current with and without Application of a Peaking Capacitor.

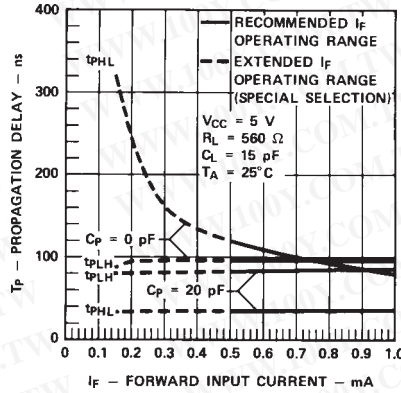

Figure 6. Typical Propagation Delay vs. Forward Current.

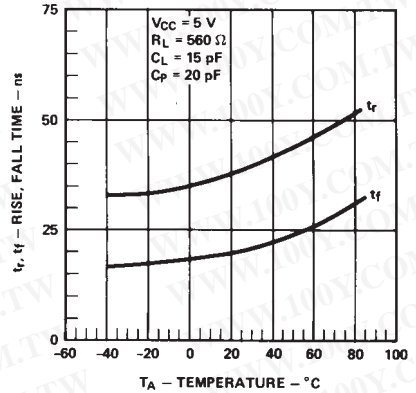

Figure 7. Typical Rise, Fall Time vs. Temperature.

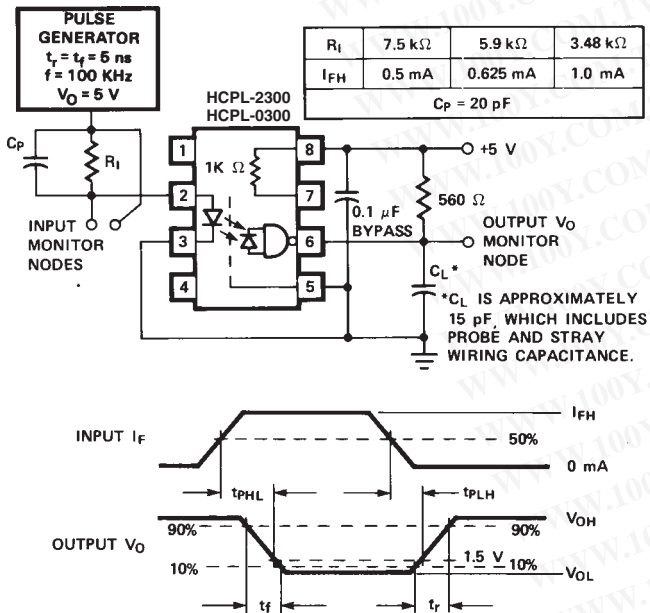

Figure 8. Test Circuit for t_{PHL} , t_{PLH} , t_r , and t_f .

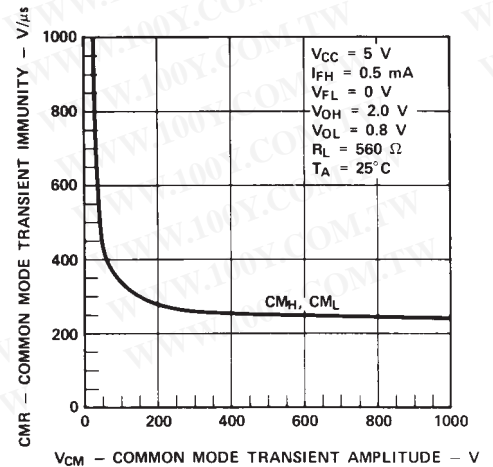

Figure 9. Typical Common Mode Transient Immunity vs. Common Mode Transient Amplitude.

勝特力材料 886-3-5753170
 勝特力电子(上海) 86-21-54151736
 勝特力电子(深圳) 86-755-83298787
 Http://www.100y.com.tw

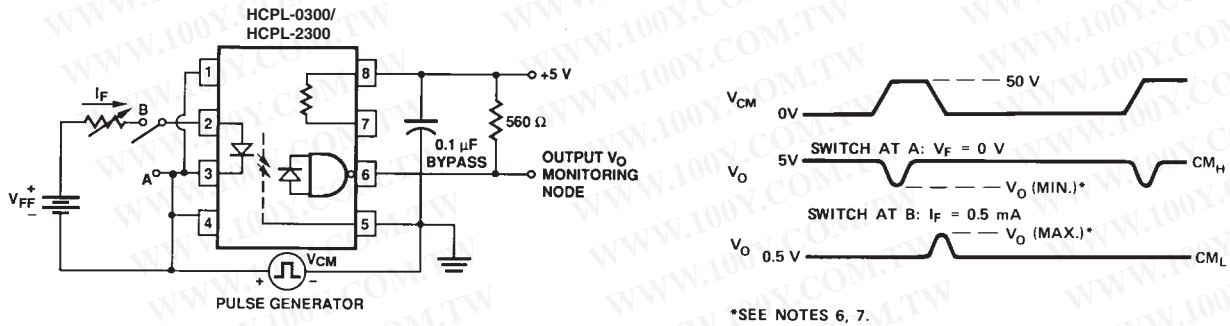

Figure 10. Test Circuit for Common Mode Transient Immunity and Typical Waveforms.

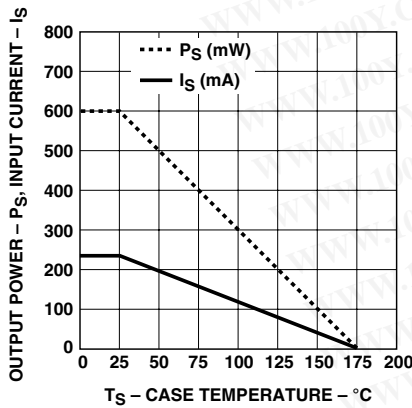

Figure 11. Thermal Derating Curve, Dependence of Safety Limiting Value with Case Temperature per IEC/EN/DIN EN 60747-5-2.

Applications

The HCPL-2300/HCPL-0300 optocoupler has the unique combination of low 0.5 mA LED operating drive current at a 5 Mbd speed performance. Low power supply current requirement of 10 mA maximum at 5.25 V and the ability to provide isolation between logic systems fulfills numerous applications ranging from logic level translations, line receiver and party line receiver applications, microprocessor I/O port isolation, etc. The open collector output allows for wired-OR arrangement. Specific interface circuits are illustrated in Figures

12-16, and 18 with corresponding component values, performance data and recommended layout in Figures 17 and 19.

For -40°C to 85°C operating temperature range, a mid-range LED forward current (I_F) of 0.625 mA is recommended in order to prevent overdriving the integrated circuit detector due to increased LED efficiency at temperatures between 0°C and -40°C . For narrower temperature range of 0°C to 85°C , a suggested operating LED current of 0.75 mA is recommended for the mid-range operating point and for minimal propagation delay skew. A peaking capacitance of 20 pF in parallel with the current limiting resistor for the LED shortens t_{PHL} by approximately 33% and t_{PLH} by 13%. Maintaining LED forward voltage (V_F) below 0.8 V will guarantee that the HCPL-2300/HCPL-0300 output is off.

The recommended shunt drive technique for TTL/LSTTL/CMOS of Figure 12 provides for optimal speed performance, no leakage current path through the LED, and reduced common mode influences associated with series switching of a "floating" LED.

Alternate series drive techniques with either an active CMOS inverter or an open collector TTL/LSTTL inverter are illustrated in Figures 13 and 14 respectively. Open collector leakage current of 250 μA has been compensated by the 3.16 K Ω resistor (Figure 14) at the expense of twice the operating forward current.

An application of the HCPL-2300/HCPL-0300 as an unbalanced line receiver for use in long line twisted wire pair communication links is shown in Figure 15. Low LED I_F and V_F allow longer line length, higher speed and multiple stations on the line in comparison to higher I_F , V_F optocouplers. Greater speed performance along with nearly infinite common mode immunity are achieved via the balanced split phase circuit of Figure 16. Basic balanced differential line receiver can be accomplished with one HCPL-2300/HCPL-0300 in Figure 16, but with a typical 400 V/ μs common mode immunity. Data rate versus distance for both the above unbalanced and balanced line receiver applications are compared in Figure 17. The RS-232-C interface circuit of Figure 18

provides guaranteed minimum common mode immunity of 100 V/ μ s while maintaining the 2:1 dynamic range of I_F .

A recommended layout for use with an internal 1000 Ω resistor

or an external pull-up resistor and required V_{CC} bypass capacitor is given in Figure 19. V_{CC1} is used with an external pull-up resistor for output voltage levels (V_O) greater than or equal to 5 V. As illustrated in Figure 19, an

optional V_{CC} and GND trace can be located between the input and the output leads of the HCPL-2300/HCPL-0300 to provide additional noise immunity at the compromise of insulation capability (V_{I-O}).

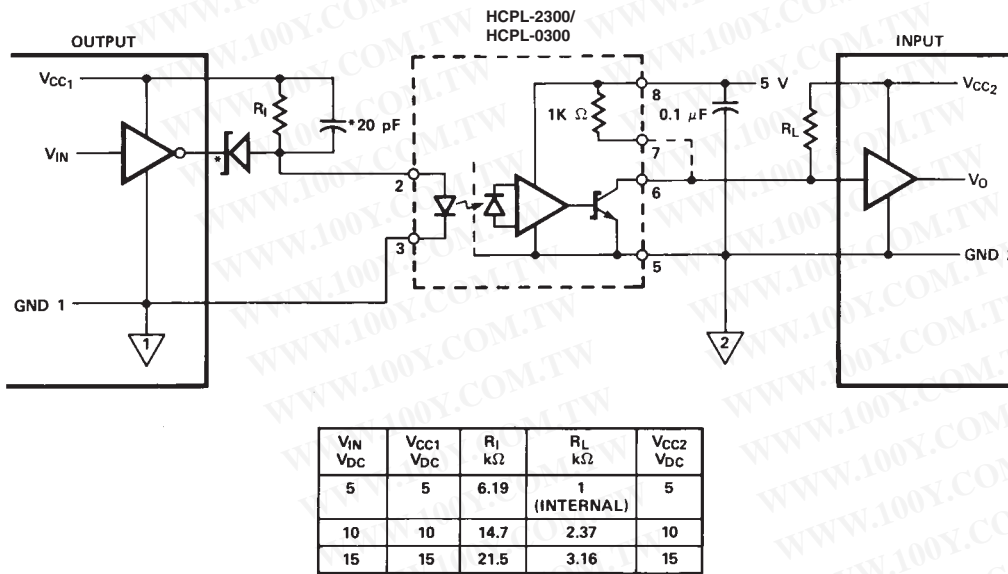

*SCHOTTKY DIODE (HP 5082-2800, OR EQUIVALENT) AND 20 pF CAPACITOR ARE NOT REQUIRED FOR UNITS WITH OPEN COLLECTOR OUTPUT.

Figure 12. Recommended Shunt Drive Circuit for Interfacing between TTL/LSTTL/CMOS Logic Systems.

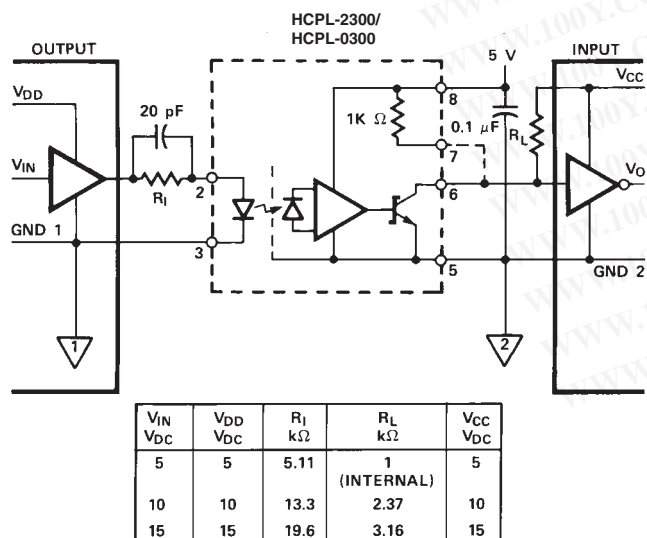

Figure 13. Active CMOS Series Drive Circuit.

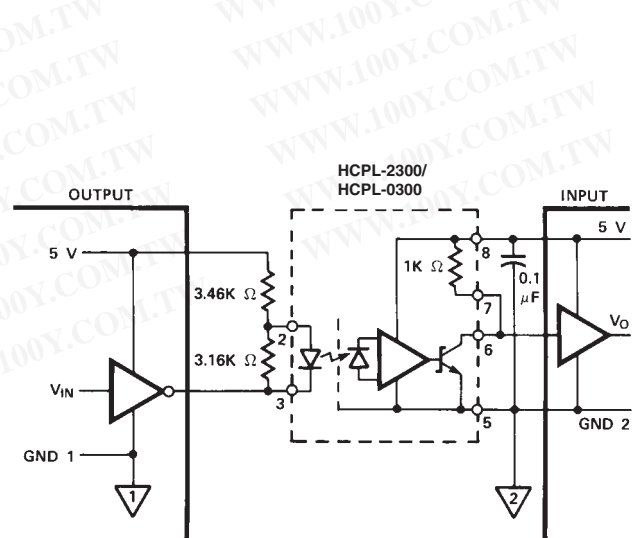

Figure 14. Series Drive from Open Collector TTL/LSTTL Units.

勝特力材料 886-3-5753170
 勝特力电子(上海) 86-21-54151736
 勝特力电子(深圳) 86-755-83298787
 Http://www.100y.com.tw

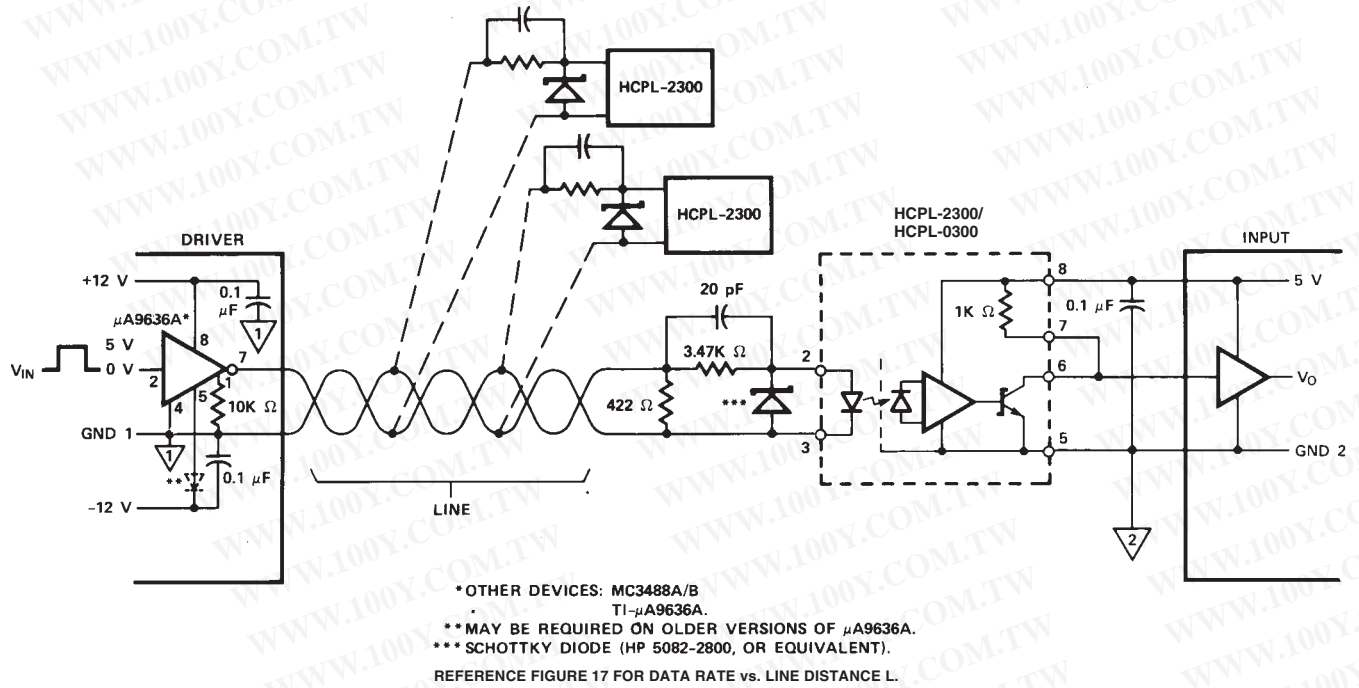

Figure 15. Application of HCPL-2300/HCPL-0300 as Isolated, Unbalanced Line Receiver(s).

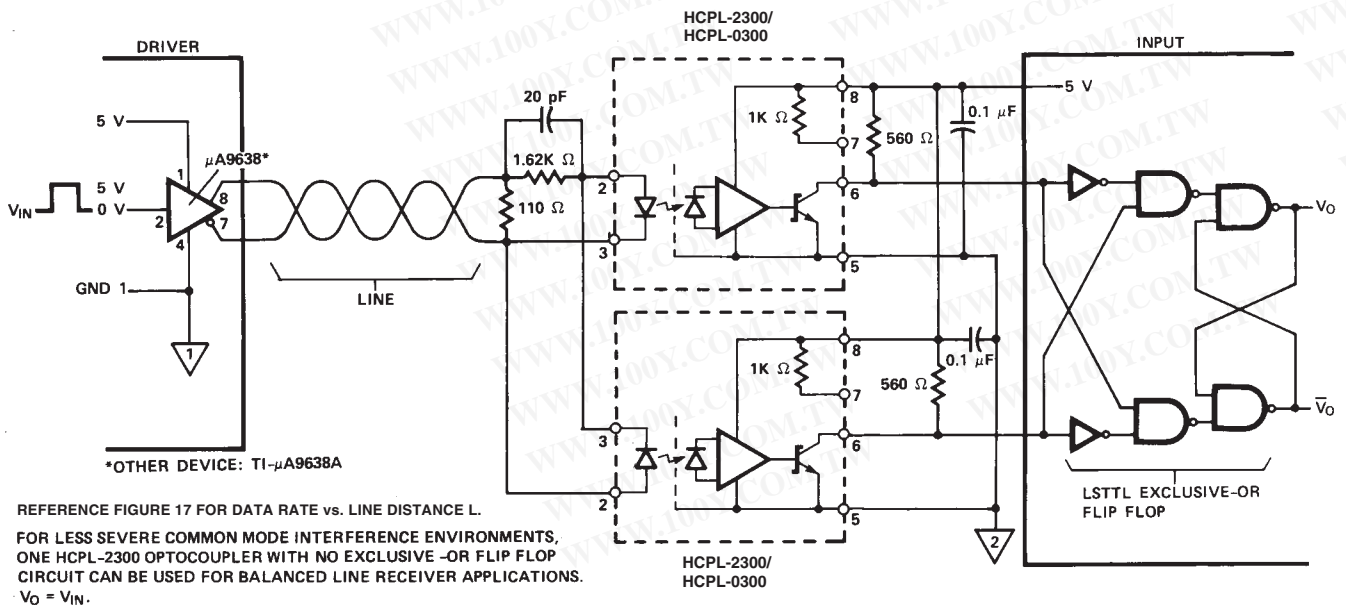

Figure 16. Application of Two HCPL-2300/HCPL-0300 Units Operating as an Isolated, High Speed, Balanced, Split Phase Line Receiver with Significantly Enhanced Common Mode Immunity.

勝特力材料 886-3-5753170
 勝特力电子(上海) 86-21-54151736
 勝特力电子(深圳) 86-755-83298787
 Http://www.100y.com.tw

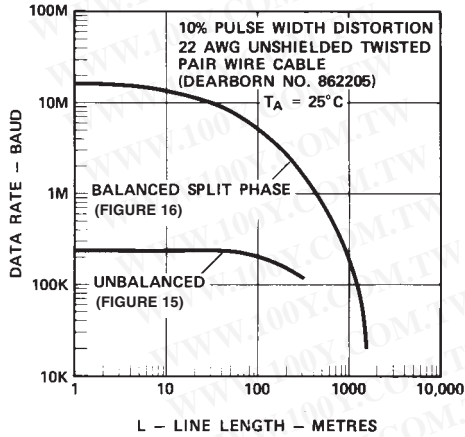

Figure 17. Typical Point to Point Data Rate vs. Length of Line for Unbalanced (Figure 15) and Balanced (Figure 16) Line Receivers Using HCPL-2300/HCPL-0300 Optocouplers.

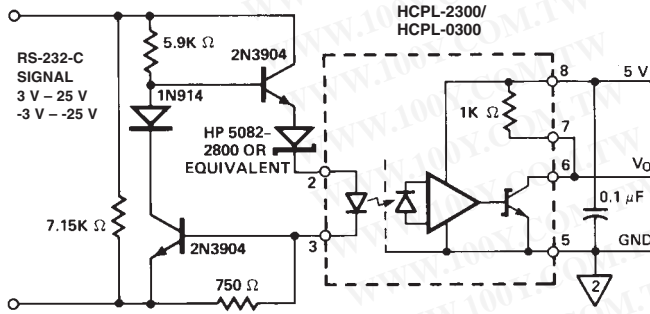
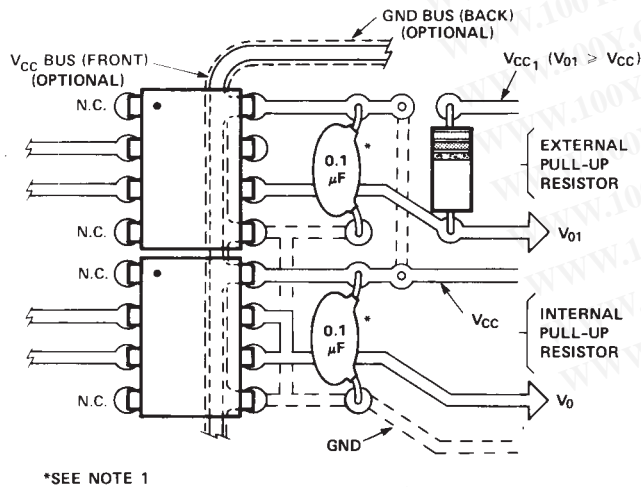

Figure 18. RS-232-C Interface Circuit with HCPL-2300/HCPL-0300. $0^{\circ}\text{C} < T_A < 85^{\circ}\text{C}$.



*SEE NOTE 1

Figure 19. Recommended Printed Circuit Board Layout.

www.agilent.com/semiconductors

For product information and a complete list of distributors, please go to our web site.

For technical assistance call:

Americas/Canada: +1 (800) 235-0312 or (916) 788-6763

Europe: +49 (0) 6441 92460

China: 10800 650 0017

Hong Kong: (+65) 6756 2394

India, Australia, New Zealand: (+65) 6755 1939

Japan: (+81 3) 3335-8152 (Domestic/International), or 0120-61-1280 (Domestic Only)

Korea: (+65) 6755 1989

Singapore, Malaysia, Vietnam, Thailand, Philippines, Indonesia: (+65) 6755 2044

Taiwan: (+65) 6755 1843

Data subject to change.

Copyright © 2005 Agilent Technologies, Inc.

Obsoletes 5989-0284EN

February 28, 2005

5989-2125EN