

Features

- Operating voltage
 - 2.4V~5V for the HT12A
 - 2.4V~12V for the HT12E
- Low power and high noise immunity CMOS technology
- Low standby current: 0.1μA (typ.) at V_{DD}=5V
- HT12A with a 38kHz carrier for infrared transmission medium
- Minimum transmission word
 - Four words for the HT12E
 - One word for the HT12A
- Built-in oscillator needs only 5% resistor
- Data code has positive polarity
- Minimal external components
- Pair with Holtek's 2¹² series of decoders
- 18-pin DIP, 20-pin SOP package

Applications

- Burglar alarm system
- Smoke and fire alarm system
- Garage door controllers
- Car door controllers
- Car alarm system
- Security system
- Cordless telephones
- Other remote control systems

General Description

The 2¹² encoders are a series of CMOS LSIs for remote control system applications. They are capable of encoding information which consists of N address bits and 12-N data bits. Each address/data input can be set to one of the two logic states. The programmed addresses/data are transmitted together with the header

bits via an RF or an infrared transmission medium upon receipt of a trigger signal. The capability to select a \overline{TE} trigger on the HT12E or a DATA trigger on the HT12A further enhances the application flexibility of the 2¹² series of encoders. The HT12A additionally provides a 38kHz carrier for infrared systems.

Selection Table

Function Part No.	Address No.	Address/ Data No.	Data No.	Oscillator	Trigger	Carrier Output	Negative Polarity	Package
HT12A	8	0	4	455kHz resonator	D8~D11	38kHz	No	18DIP, 20SOP
HT12E	8	4	0	RC oscillator	\overline{TE}	No	No	18DIP, 20SOP

Note: Address/Data represents pins that can be either address or data according to the application requirement.

勝特力材料 886-3-5753170
 勝特力电子(上海) 86-21-54151736
 勝特力电子(深圳) 86-755-83298787
[Http://www.100y.com.tw](http://www.100y.com.tw)

Block Diagram

TE Trigger

HT12E

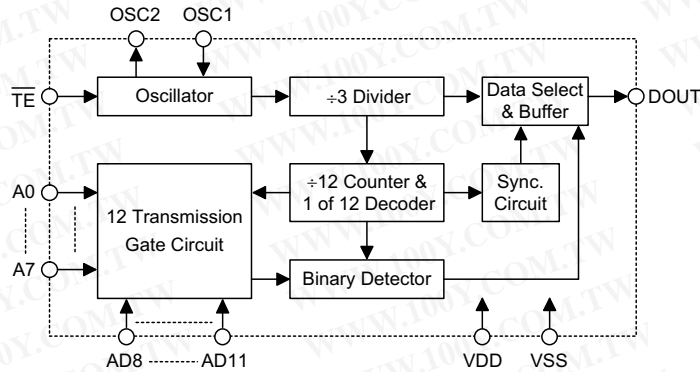

DATA Trigger

HT12A

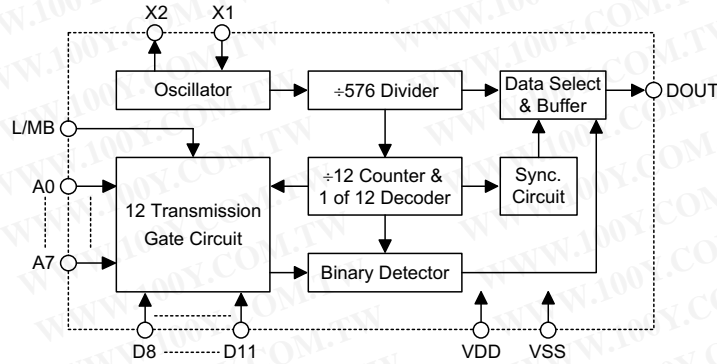

Note: The address data pins are available in various combinations (refer to the address/data table).

Pin Assignment

**8-Address
4-Data**

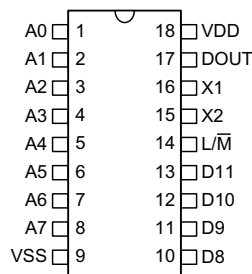

**HT12A
-18 DIP-A**

**8-Address
4-Data**

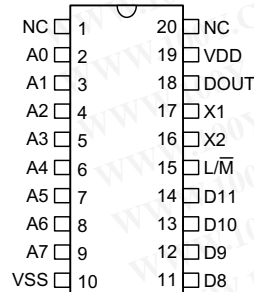

**HT12A
-20 SOP-A**

**8-Address
4-Address/Data**

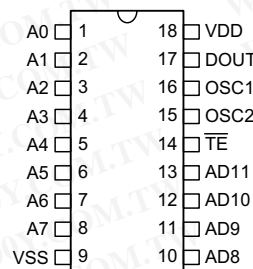

**HT12E
-18 DIP-A**

**8-Address
4-Address/Data**

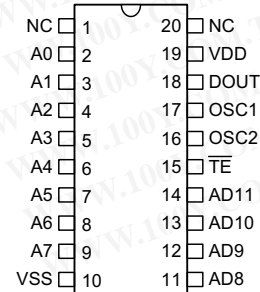

**HT12E
-20 SOP-A**

Pin Description

Pin Name	I/O	Internal Connection	Description
A0~A7	I	CMOS IN Pull-high (HT12A)	Input pins for address A0~A7 setting These pins can be externally set to VSS or left open
		NMOS TRANSMISSION GATE PROTECTION DIODE (HT12E)	
AD8~AD11	I	NMOS TRANSMISSION GATE PROTECTION DIODE (HT12E)	Input pins for address/data AD8~AD11 setting These pins can be externally set to VSS or left open
D8~D11	I	CMOS IN Pull-high	Input pins for data D8~D11 setting and transmission enable, active low These pins should be externally set to VSS or left open (see Note)
DOUT	O	CMOS OUT	Encoder data serial transmission output
$\overline{L/M}$	I	CMOS IN Pull-high	Latch/Momentary transmission format selection pin: Latch: Floating or VDD Momentary: VSS
\overline{TE}	I	CMOS IN Pull-high	Transmission enable, active low (see Note)
OSC1	I	OSCILLATOR 1	Oscillator input pin
OSC2	O	OSCILLATOR 1	Oscillator output pin
X1	I	OSCILLATOR 2	455kHz resonator oscillator input
X2	O	OSCILLATOR 2	455kHz resonator oscillator output
VSS	I	—	Negative power supply, ground
VDD	I	—	Positive power supply

Note: D8~D11 are all data input and transmission enable pins of the HT12A.

\overline{TE} is a transmission enable pin of the HT12E.

Approximate Internal Connections

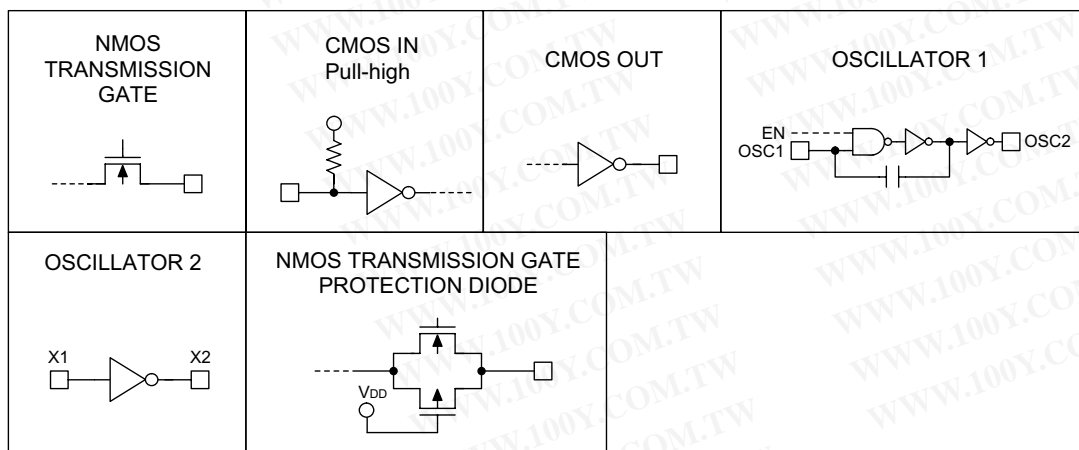

Absolute Maximum Ratings

Supply Voltage (HT12A)	$V_{SS}-0.3V$ to $V_{SS}+5.5V$	Supply Voltage (HT12E)	$-0.3V$ to $13V$
Input Voltage	$V_{SS}-0.3$ to $V_{DD}+0.3V$	Storage Temperature	$-50^{\circ}C$ to $125^{\circ}C$
Operating Temperature	$-20^{\circ}C$ to $75^{\circ}C$		

Note: These are stress ratings only. Stresses exceeding the range specified under "Absolute Maximum Ratings" may cause substantial damage to the device. Functional operation of this device at other conditions beyond those listed in the specification is not implied and prolonged exposure to extreme conditions may affect device reliability.

Electrical Characteristics

HT12A

$T_a=25^{\circ}C$

Symbol	Parameter	Test Conditions		Min.	Typ.	Max.	Unit
		V_{DD}	Conditions				
V_{DD}	Operating Voltage	—	—	2.4	3	5	V
I_{STB}	Standby Current	3V	Oscillator stops	—	0.1	1	μA
		5V		—	0.1	1	μA
I_{DD}	Operating Current	3V	No load $f_{OSC}=455kHz$	—	200	400	μA
		5V		—	400	800	μA
I_{DOUT}	Output Drive Current	5V	$V_{OH}=0.9V_{DD}$ (Source)	-1	-1.6	—	mA
			$V_{OL}=0.1V_{DD}$ (Sink)	2	3.2	—	mA
V_{IH}	"H" Input Voltage	—	—	$0.8V_{DD}$	—	V_{DD}	V
V_{IL}	"L" Input Voltage	—	—	0	—	$0.2V_{DD}$	V
R_{DATA}	D8~D11 Pull-high Resistance	5V	$V_{DATA}=0V$	—	150	300	$k\Omega$

HT12E

$T_a=25^{\circ}C$

Symbol	Parameter	Test Conditions		Min.	Typ.	Max.	Unit
		V_{DD}	Conditions				
V_{DD}	Operating Voltage	—	—	2.4	5	12	V
I_{STB}	Standby Current	3V	Oscillator stops	—	0.1	1	μA
		12V		—	2	4	μA
I_{DD}	Operating Current	3V	No load, $f_{OSC}=3kHz$	—	40	80	μA
		12V		—	150	300	μA
I_{DOUT}	Output Drive Current	5V	$V_{OH}=0.9V_{DD}$ (Source)	-1	-1.6	—	mA
			$V_{OL}=0.1V_{DD}$ (Sink)	1	1.6	—	mA
V_{IH}	"H" Input Voltage	—	—	$0.8V_{DD}$	—	V_{DD}	V
V_{IL}	"L" Input Voltage	—	—	0	—	$0.2V_{DD}$	V
f_{OSC}	Oscillator Frequency	5V	$R_{OSC}=1.1M\Omega$	—	3	—	kHz
$R_{\overline{TE}}$	\overline{TE} Pull-high Resistance	5V	$V_{\overline{TE}}=0V$	—	1.5	3	$M\Omega$

Functional Description

Operation

The 2¹² series of encoders begin a 4-word transmission cycle upon receipt of a transmission enable (\overline{TE} for the HT12E or D8~D11 for the HT12A, active low). This cycle will repeat itself as long as the transmission enable (\overline{TE} or D8~D11) is held low. Once the transmission enable returns high the encoder output completes its final cycle and then stops as shown below.

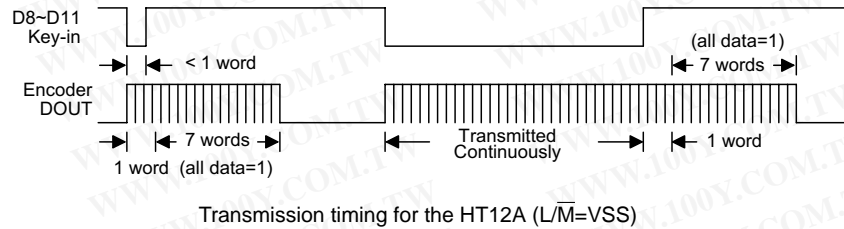
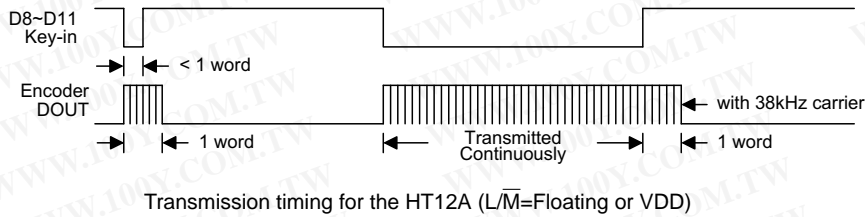
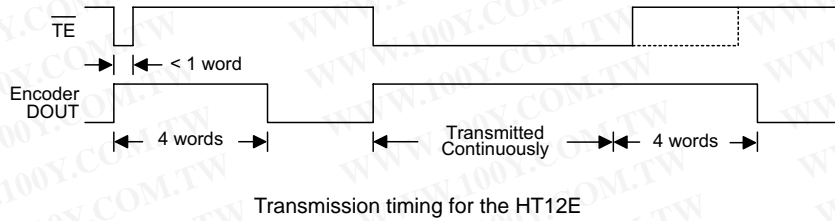

Information Word

If $L/\overline{M}=1$ the device is in the latch mode (for use with the latch type of data decoders). When the transmission enable is removed during a transmission, the DOUT pin outputs a complete word and then stops. On the other hand, if $L/\overline{M}=0$ the device is in the momentary mode (for use with the momentary type of data decoders). When the transmission enable is removed during a transmission, the DOUT outputs a complete word and then adds 7 words all with the "1" data code.

An information word consists of 4 periods as illustrated below.

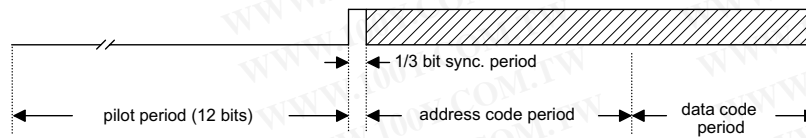

勝特力材料 886-3-5753170
 勝特力电子(上海) 86-21-54151736
 勝特力电子(深圳) 86-755-83298787
 Http://www.100y.com.tw

Address/Data Waveform

Each programmable address/data pin can be externally set to one of the following two logic states as shown below.

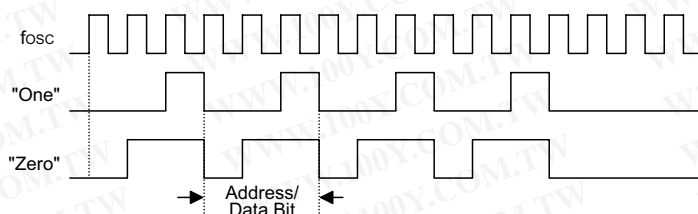

Address/Data bit waveform for the HT12E

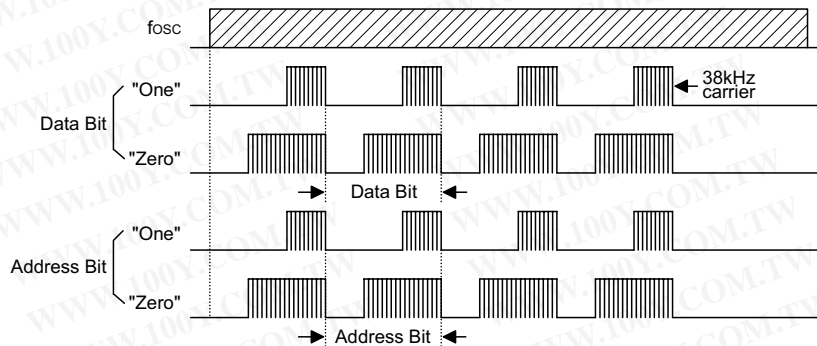

Address/Data bit waveform for the HT12A

The address/data bits of the HT12A are transmitted with a 38kHz carrier for infrared remote controller flexibility.

Address/Data Programming (Preset)

The status of each address/data pin can be individually pre-set to logic "high" or "low". If a transmission-enable signal is applied, the encoder scans and transmits the status of the 12 bits of address/data serially in the order A0 to AD11 for the HT12E encoder and A0 to D11 for the HT12A encoder.

During information transmission these bits are transmitted with a preceding synchronization bit. If the trigger signal is not applied, the chip enters the standby mode and consumes a reduced current of less than 1μA for a supply voltage of 5V.

Usual applications preset the address pins with individual security codes using DIP switches or PCB wiring, while the data is selected by push buttons or electronic switches.

The following figure shows an application using the HT12E:

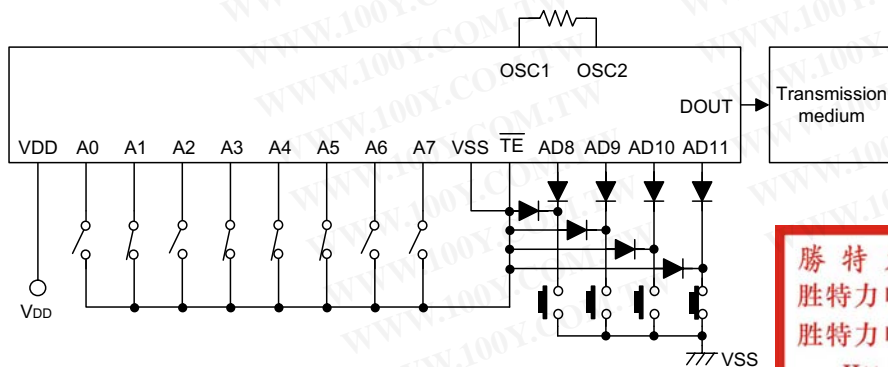

勝特力材料 886-3-5753170
 勝特力电子(上海) 86-21-54151736
 勝特力电子(深圳) 86-755-83298787
[Http://www.100y.com.tw](http://www.100y.com.tw)

The transmitted information is as shown:

Pilot & Sync.	A0	A1	A2	A3	A4	A5	A6	A7	AD8	AD9	AD10	AD11
	1	0	1	0	0	0	1	1	1	1	1	0

Address/Data Sequence

The following provides the address/data sequence table for various models of the 2¹² series of encoders.

Part No.	Address/Data Bits											
	0	1	2	3	4	5	6	7	8	9	10	11
HT12A	A0	A1	A2	A3	A4	A5	A6	A7	D8	D9	D10	D11
HT12E	A0	A1	A2	A3	A4	A5	A6	A7	AD8	AD9	AD10	AD11

Transmission Enable

For the HT12E encoders, transmission is enabled by applying a low signal to the \overline{TE} pin. For the HT12A encoders, transmission is enabled by applying a low signal to one of the data pins D8-D11.

Two Erroneous HT12E Application Circuits

The HT12E must follow closely the application circuits provided by Holtek (see the "Application circuits").

- Error: AD8~AD11 pins input voltage > $V_{DD}+0.3V$

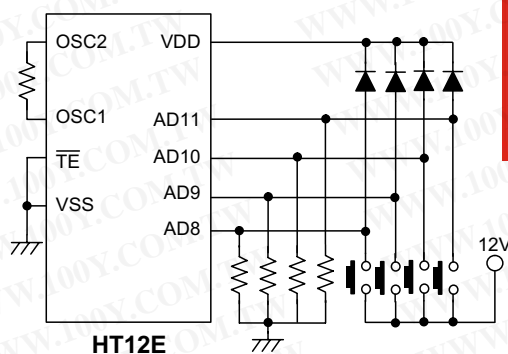

勝特力材料 886-3-5753170
 勝特力电子(上海) 86-21-54151736
 勝特力电子(深圳) 86-755-83298787
[Http://www.100y.com.tw](http://www.100y.com.tw)

- Error: The IC's power source is activated by pins AD8~AD11

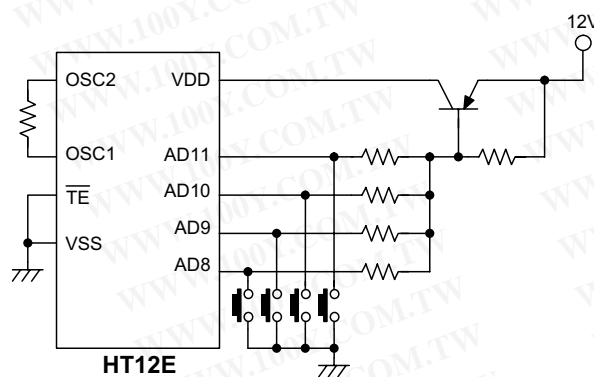

Flowchart

• HT12A

• HT12E

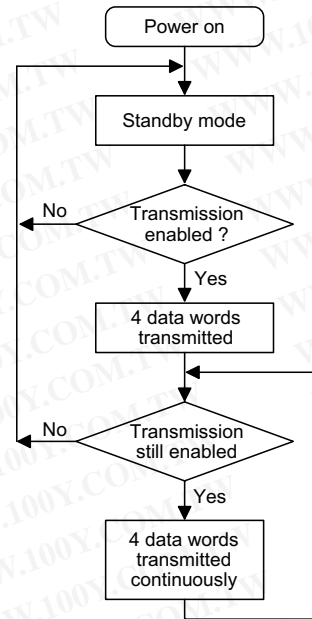
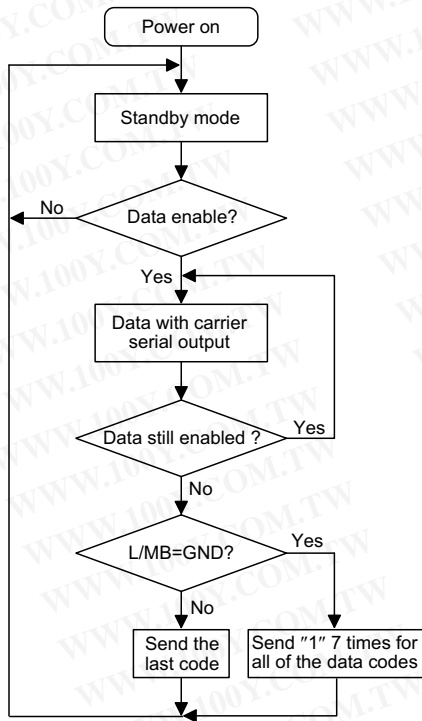

Note: D8-D11 are transmission enables of the HT12A.
 $\overline{\text{TE}}$ is the transmission enable of the HT12E.

勝特力材料 886-3-5753170
 勝特力电子(上海) 86-21-54151736
 勝特力电子(深圳) 86-755-83298787
[Http://www.100y.com.tw](http://www.100y.com.tw)

Oscillator Frequency vs. Supply Voltage

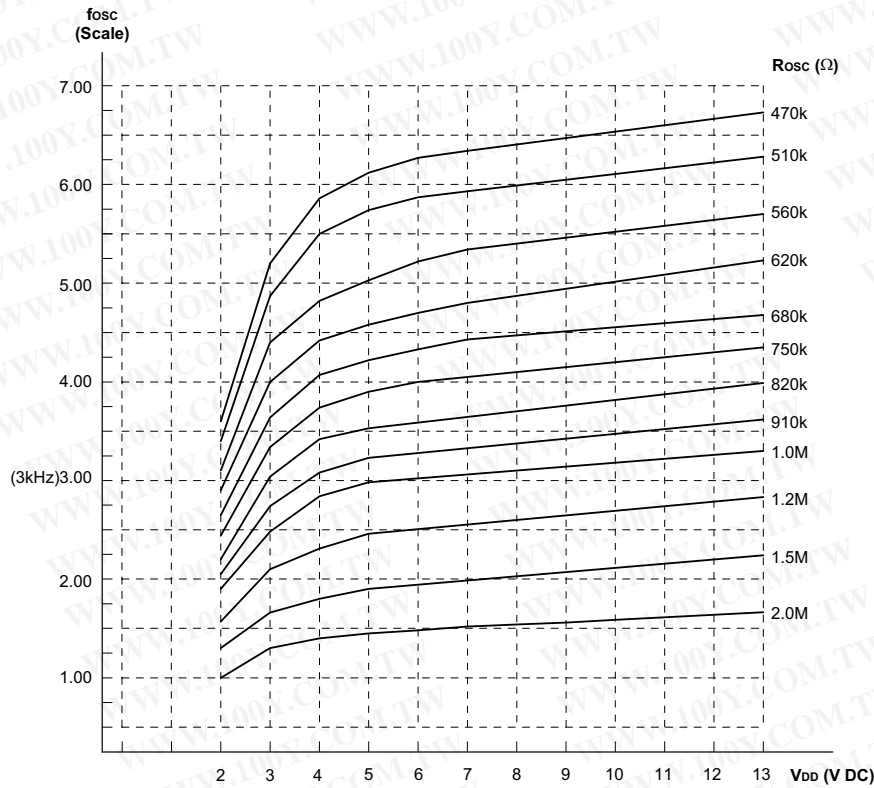

The recommended oscillator frequency is $f_{OSC D}(\text{decoder}) \cong 50 f_{OSCE}(\text{HT12E encoder})$
 $\cong \frac{1}{3} f_{OSCE}(\text{HT12A encoder})$

Application Circuits

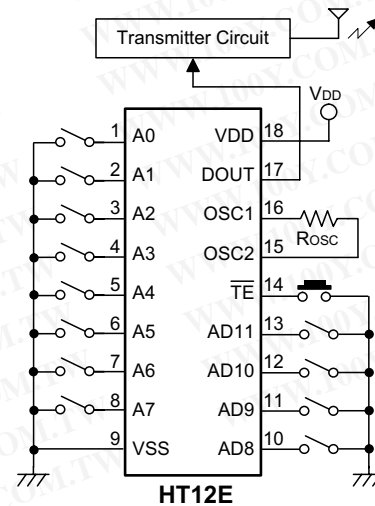
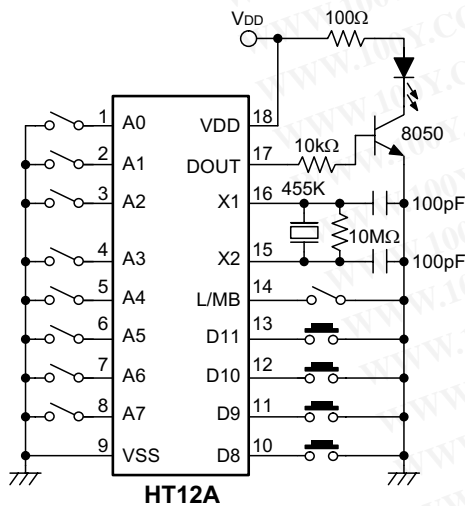

Package Information

18-pin DIP (300mil) Outline Dimensions

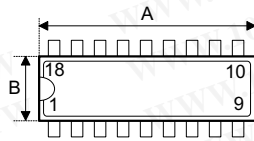

勝特力材料 886-3-5753170
 勝特力电子(上海) 86-21-54151736
 勝特力电子(深圳) 86-755-83298787
[Http://www.100y.com.tw](http://www.100y.com.tw)

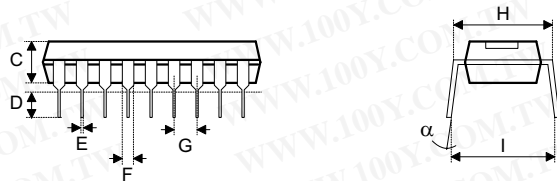

Symbol	Dimensions in mil		
	Min.	Nom.	Max.
A	895	—	915
B	240	—	260
C	125	—	135
D	125	—	145
E	16	—	20
F	50	—	70
G	—	100	—
H	295	—	315
I	335	—	375
α	0°	—	15°

20-pin SOP (300mil) Outline Dimensions

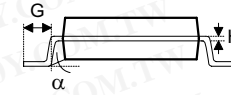
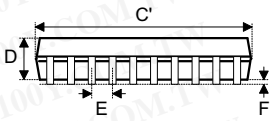
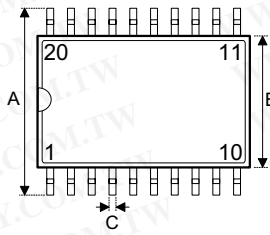

勝特力材料 886-3-5753170
 勝特力电子(上海) 86-21-54151736
 勝特力电子(深圳) 86-755-83298787
[Http://www.100y.com.tw](http://www.100y.com.tw)

Symbol	Dimensions in mil		
	Min.	Nom.	Max.
A	394	—	419
B	290	—	300
C	14	—	20
C'	490	—	510
D	92	—	104
E	—	50	—
F	4	—	—
G	32	—	38
H	4	—	12
α	0°	—	10°

Product Tape and Reel Specifications

Reel Dimensions

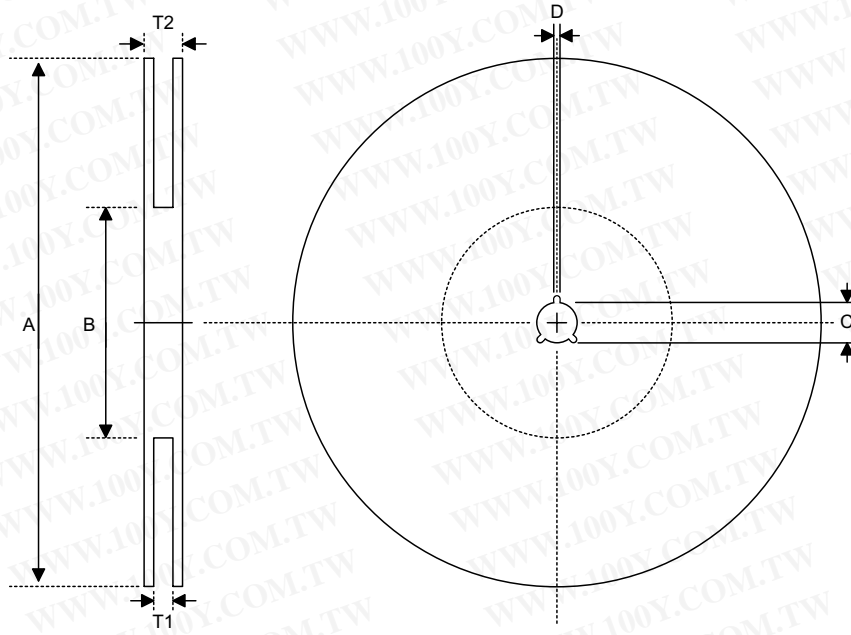

SOP 20W

Symbol	Description	Dimensions in mm
A	Reel Outer Diameter	330±1.0
B	Reel Inner Diameter	62±1.5
C	Spindle Hole Diameter	13.0+0.5 -0.2
D	Key Slit Width	2.0±0.5
T1	Space Between Flange	24.8+0.3 -0.2
T2	Reel Thickness	30.2±0.2

勝特力材料 886-3-5753170
 勝特力电子(上海) 86-21-54151736
 勝特力电子(深圳) 86-755-83298787
[Http://www.100y.com.tw](http://www.100y.com.tw)

Carrier Tape Dimensions

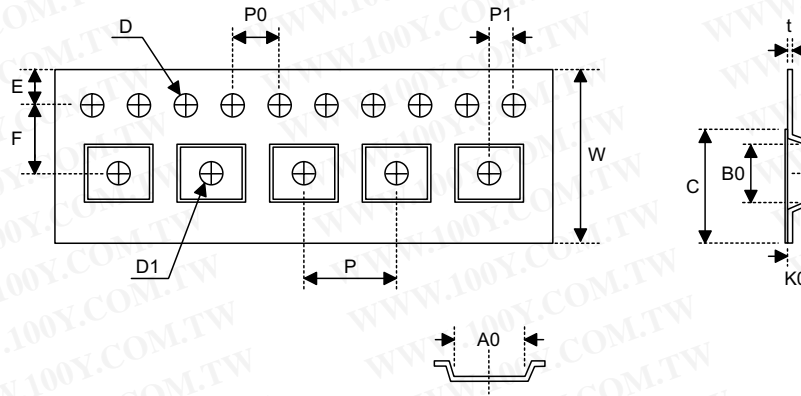

SOP 20W

Symbol	Description	Dimensions in mm
W	Carrier Tape Width	24.0+0.3 -0.1
P	Cavity Pitch	12.0±0.1
E	Perforation Position	1.75±0.1
F	Cavity to Perforation (Width Direction)	11.5±0.1
D	Perforation Diameter	1.5+0.1
D1	Cavity Hole Diameter	1.5+0.25
P0	Perforation Pitch	4.0±0.1
P1	Cavity to Perforation (Length Direction)	2.0±0.1
A0	Cavity Length	10.8±0.1
B0	Cavity Width	13.3±0.1
K0	Cavity Depth	3.2±0.1
t	Carrier Tape Thickness	0.3±0.05
C	Cover Tape Width	21.3

勝特力材料 886-3-5753170
勝特力电子(上海) 86-21-54151736
勝特力电子(深圳) 86-755-83298787
[Http://www.100y.com.tw](http://www.100y.com.tw)

勝特力材料 886-3-5753170
勝特力电子(上海) 86-21-54151736
勝特力电子(深圳) 86-755-83298787
[Http://www.100y.com.tw](http://www.100y.com.tw)

Holtek Semiconductor Inc. (Headquarters)
No.3, Creation Rd. II, Science Park, Hsinchu, Taiwan
Tel: 886-3-563-1999
Fax: 886-3-563-1189
<http://www.holtek.com.tw>

Holtek Semiconductor Inc. (Taipei Sales Office)
4F-2, No. 3-2, YuanQu St., Nankang Software Park, Taipei 115, Taiwan
Tel: 886-2-2655-7070
Fax: 886-2-2655-7373
Fax: 886-2-2655-7383 (International sales hotline)

Holtek Semiconductor Inc. (Shanghai Sales Office)
7th Floor, Building 2, No.889, Yi Shan Rd., Shanghai, China 200233
Tel: 021-6485-5560
Fax: 021-6485-0313
<http://www.holtek.com.cn>

Holtek Semiconductor Inc. (Shenzhen Sales Office)
43F, SEG Plaza, Shen Nan Zhong Road, Shenzhen, China 518031
Tel: 0755-8346-5589
Fax: 0755-8346-5590
ISDN: 0755-8346-5591

Holtek Semiconductor Inc. (Beijing Sales Office)
Suite 1721, Jinyu Tower, A129 West Xuan Wu Men Street, Xicheng District, Beijing, China 100031
Tel: 010-6641-0030, 6641-7751, 6641-7752
Fax: 010-6641-0125

Holmate Semiconductor, Inc. (North America Sales Office)
46712 Fremont Blvd., Fremont, CA 94538
Tel: 510-252-9880
Fax: 510-252-9885
<http://www.holmate.com>

Copyright © 2003 by HOLTEK SEMICONDUCTOR INC.

The information appearing in this Data Sheet is believed to be accurate at the time of publication. However, Holtek assumes no responsibility arising from the use of the specifications described. The applications mentioned herein are used solely for the purpose of illustration and Holtek makes no warranty or representation that such applications will be suitable without further modification, nor recommends the use of its products for application that may present a risk to human life due to malfunction or otherwise. Holtek's products are not authorized for use as critical components in life support devices or systems. Holtek reserves the right to alter its products without prior notification. For the most up-to-date information, please visit our web site at <http://www.holtek.com.tw>.