

International **IR** Rectifier

IPS511G/IPS512G

FULLY PROTECTED HIGH SIDE POWER MOSFET SWITCH

Features

- Over temperature protection (with auto-restart)
- Short-circuit protection (current limit)
- Active clamp
- E.S.D protection
- Status feedback
- Open load detection
- Logic ground isolated from power ground

Description

The IPS511G/IPS512G are fully protected five terminal high side switches with built in short-circuit, over-temperature, ESD protection, inductive load capability and diagnostic feedback. The output current is controlled when it reaches I_{lim} value. The current limitation is activated until the thermal protection acts. The over-temperature protection turns off the high side switch if the junction temperature exceeds $T_{shutdown}$. It will automatically restart after the junction has cooled 7°C below $T_{shutdown}$. A diagnostic pin is provided for status feedback of short-circuit, over-temperature and open load detection. The double level shifter circuitry allows large offsets between the logic ground and the load ground.

Product Summary

$R_{ds(on)}$	150m Ω (max)
V_{clamp}	50V
I Limit	5A
$V_{open\ load}$	3V

Truth Table

Op. Conditions	In	Out	Dg
Normal	H	H	H
Normal	L	L	L
Open load	H	H	H
Open load	L	H	H
Over current	H	L (limiting)	L
Over current	L	L	L
Over-temperature	H	L (cycling)	L
Over-temperature	L	L	L

Typical Connection

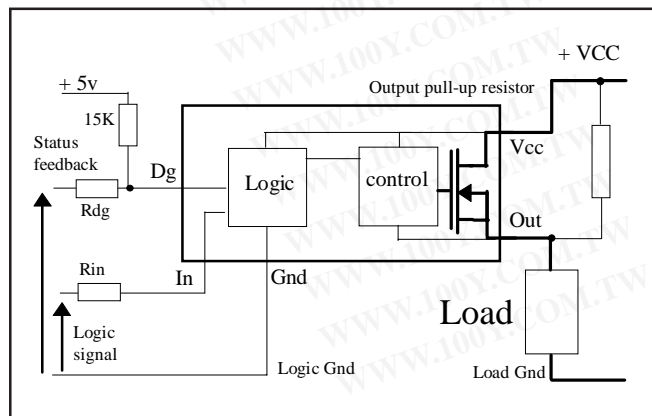

Available Package

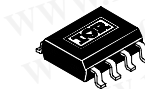

8 Lead SOIC
 (Single)
 IPS511G

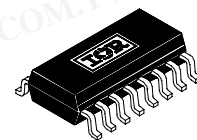

16 Lead SOIC
 (Dual)
 IPS512G

IPS511G/IPS512G

International
 Rectifier

Absolute Maximum Ratings

Absolute maximum ratings indicate sustained limits beyond which damage to the device may occur. All voltage parameters are referenced to GROUND lead. ($T_j = 25^\circ\text{C}$ unless otherwise specified).

Symbol	Parameter	Min.	Max.	Units	Test Conditions
V_{out}	Maximum output voltage	$V_{CC}-50$	$V_{CC}+0.3$	V	
V_{offset}	Maximum logic ground to load ground offset	$V_{CC}-50$	$V_{CC}+0.3$		
V_{in}	Maximum Input voltage	-0.3	5.5		
$I_{in, max}$	Maximum IN current	-5	10	mA	
V_{dg}	Maximum diagnostic output voltage	-0.3	5.5	V	
$I_{dg, max}$	Maximum diagnostic output current	-1	10	mA	
$I_{sd cont.}$	Diode max. continuous current ⁽¹⁾ (IPS511G) (per leg/both legs ON - IPS512G)	—	1.4	A	
		—	0.8		
$I_{sd pulsed}$	Diode max. pulsed current ⁽¹⁾	—	10		
ESD1	Electrostatic discharge voltage (Human Body)	—	4000	V	C=100pF, R=1500 Ω ,
ESD2	Electrostatic discharge voltage (Machine Model)	—	500		C=200pF, R=0 Ω , L=10 μ H
P_d	Maximum power dissipation ($r_{th}=125^\circ\text{C/W}$) IPS511G	—	1	W	
	($r_{th}=85^\circ\text{C/W}$, both legs on) IPS512G	—	1.5		
$T_j max.$	Max. storage & operating junction temp.	-40	+150	$^\circ\text{C}$	
$V_{vv max}$	Maximum Vcc voltage	—	50	V	

Thermal Characteristics

Symbol	Parameter	Min.	Typ.	Max.	Units	Test Conditions
R_{th1}	Thermal resistance with standard footprint	—	100	—		8 Lead SOIC
R_{th2}	Thermal resistance with 1" square footprint	—	80	—		
R_{th1} (2 mos on)	Thermal resistance with standard footprint (2 mosfets on)	—	85	—	$^\circ\text{C/W}$	16 Lead SOIC
R_{th2} (1) (1 mos on)	Thermal resistance with standard footprint (1 mosfet on)	—	100	—		
R_{th2} (2 mos on)	Thermal resistance with 1" square footprint (2 mosfets on)	—	50	—		

(1) Limited by junction temperature (pulsed current limited also by internal wiring)

IPS511G/IPS512G

Recommended Operating Conditions

These values are given for a quick design. For operation outside these conditions, please consult the application notes.

Symbol	Parameter	Min.	Max.	Units
V _{CC}	Continuous V _{CC} voltage	5.5	35	V
V _{IH}	High level input voltage	4	5.5	
V _{IL}	Low level input voltage	-0.3	0.9	
I _{out} T _{amb} =85°C	Continuous output current (T _{Ambient} = 85°C, T _J = 125°C, r _{th} = 100°C/W) IPS511G	—	1.4	A
I _{out} T _{amb} =85°C	Continuous output current per leg (T _{Ambient} = 85°C, T _J = 125°C R _{th} = 85°C/W both legs on) IPS512G	—	1.0	
R _{in}	Recommended resistor in series with IN pin	4	6	kΩ
R _{dg}	Recommended resistor in series with DG pin	10	20	

Static Electrical Characteristics

(T_J = 25°C, V_{CC} = 14V unless otherwise specified.)

Symbol	Parameter	Min.	Typ.	Max.	Units	Test Conditions
R _{ds(on)} @T _J =25°C	ON state resistance T _J = 25°C	—	130	150	mΩ	V _{in} = 5V, I _{out} = 2.5A
R _{ds(on)} (V _{CC} =6V)	ON state resistance @ V _{CC} = 6V	—	130	150		V _{in} = 5V, I _{out} = 1A
R _{ds(on)} @T _J =150°C	ON state resistance T _J = 150°C	—	220	—		V _{in} = 5V, I _{out} = 2.5A
V _{CC oper.}	Operating voltage range	5.5	—	35	V	
V _{clamp 1}	V _{CC} to OUT clamp voltage 1	50	56	—		I _d = 10mA (see Fig.1 & 2)
V _{clamp 2}	V _{CC} to OUT clamp voltage 2	—	58	65		I _d = I _{sd} (see Fig.1 & 2)
V _f	Body diode forward voltage	—	0.9	1.2	μA	I _d = 2.5A, V _{in} = 0V
I _{CC off}	Supply current when OFF	—	16	50		V _{in} = 0V, V _{out} = 0V
I _{CC on}	Supply current when ON	—	0.7	2	mA	V _{in} = 5V
I _{CC ac}	Ripple current when ON (AC RMS)	—	20	—	μA	V _{in} = 5V
V _{dgl}	Low level diagnostic output voltage	—	0.15	0.4	V	I _{dg} = 1.6 mA
I _{ol}	Output leakage current	—	60	120	μA	V _{out} = 6V
I _{ol}	Output leakage current	0	—	25		V _{out} = 0V
I _{dg leakage}	Diagnostic output leakage current	—	—	10		V _{dg} = 5.5V
V _{Ih}	IN high threshold voltage	—	2.3	2.5	V	
V _{Il}	IN low threshold voltage	1	2	—		
I _{in, on}	On state IN positive current	—	70	200	μA	V _{in} = 5V
I _{n, hyst.}	Input hysteresis	0.1	0.25	0.5	V	

IPS511G/IPS512G

International
IR Rectifier

Switching Electrical Characteristics

V_{CC} = 14V, Resistive Load = 5.6Ω, T_j = 25°C, (unless otherwise specified).

Symbol	Parameter	Min.	Typ.	Max.	Units	Test Conditions
T _{don}	Turn-on delay time	—	7	50	μs	See figure 3
T _{r1}	Rise time to V _{out} = V _{CC} - 5V	—	10	50		
T _{r2}	Rise time from the end of TR1 to V _{out} = 90% of V _{CC}	—	45	95		
dV/dt (on)	Turn ON dV/dt	—	1.3	4	V/μs	
E _{on}	Turn ON energy	—	400	—	μs	See figure 4
T _{doff}	Turn-off delay time	—	15	50		
T _f	Fall time to V _{out} = 10% of V _{CC}	—	10	50		
dV/dt (off)	Turn OFF dV/dt	—	2	6	V/μs	
E _{off}	Turn OFF energy	—	80	—	μJ	
T _{diag}	V _{out} to V _{diag} propagation delay	—	5	15	μs	

Protection Characteristics

Symbol	Parameter	Min.	Typ.	Max.	Units	Test Conditions
I _{lim}	Internal current limit	3	5	7	A	V _{out} = 0V
T _{sd+}	Over-temp. positive going threshold	—	165	—	°C	See fig. 2
T _{sd-}	Over-temp. negative going threshold	—	158	—	°C	See fig. 2
V _{sc}	Short-circuit detection voltage (3)	2	3	4	V	See fig. 2
V _{open load}	Open load detection threshold	2	3	4	V	

(3) Referenced to V_{CC}

Lead Assignments

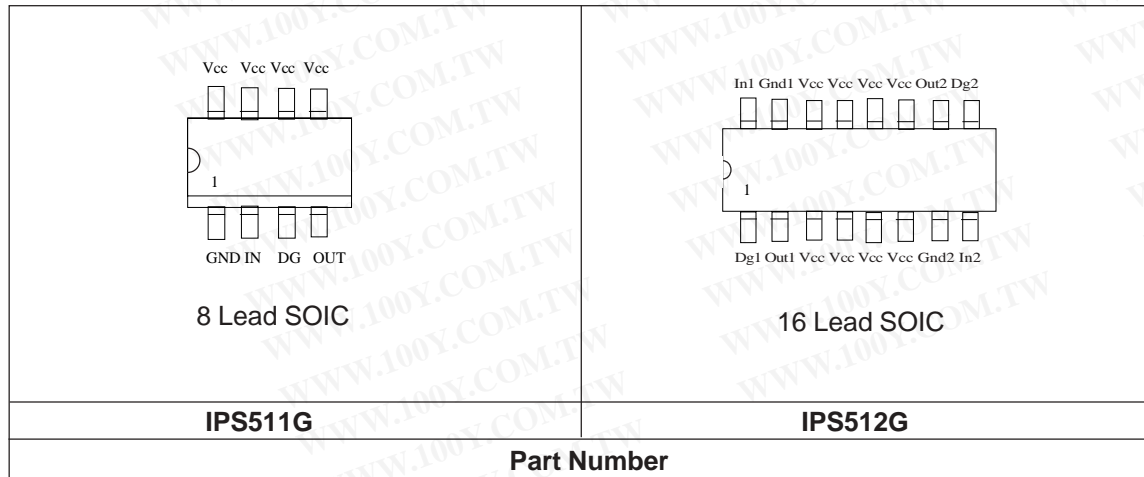

International
IR Rectifier

IPS511G/IPS512G

Functional Block Diagram

All values are typical

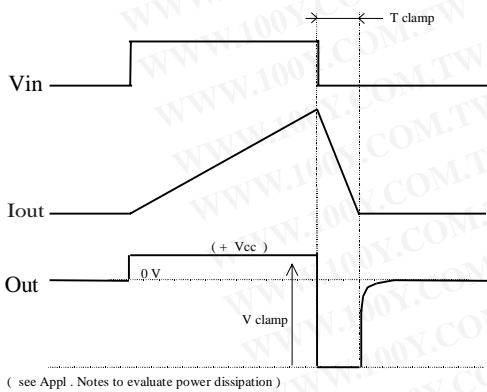
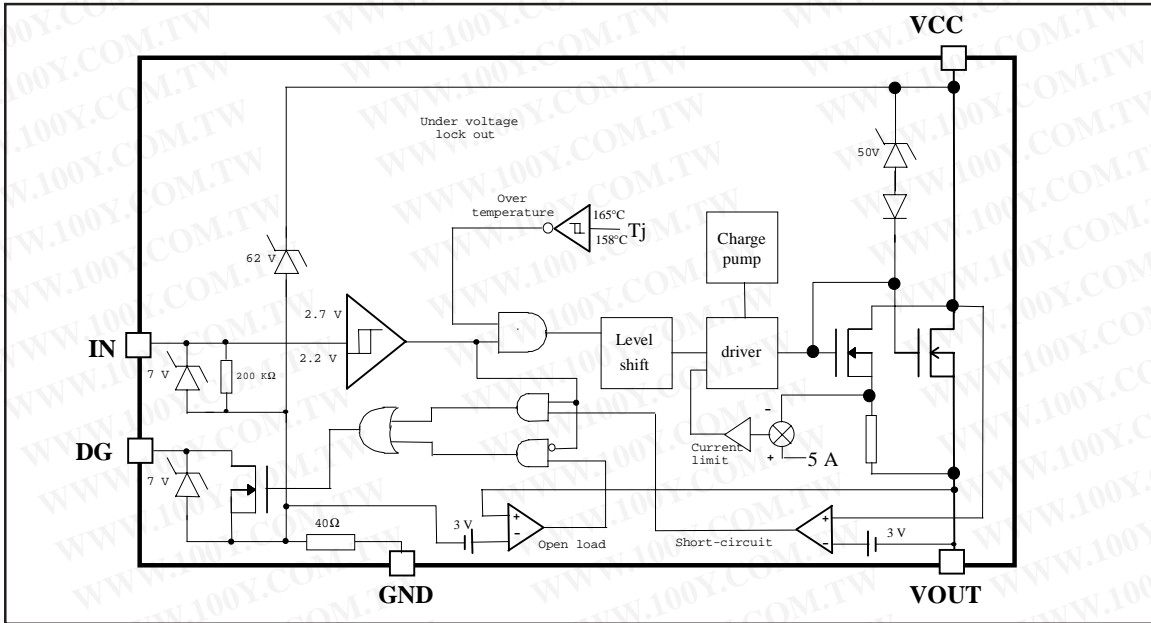

Figure 1 - Active clamp waveforms

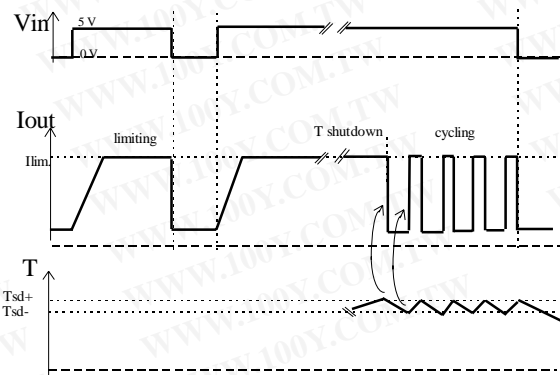

Figure 2 - Protection timing diagram

IPS511G/IPS512G

International
IR Rectifier

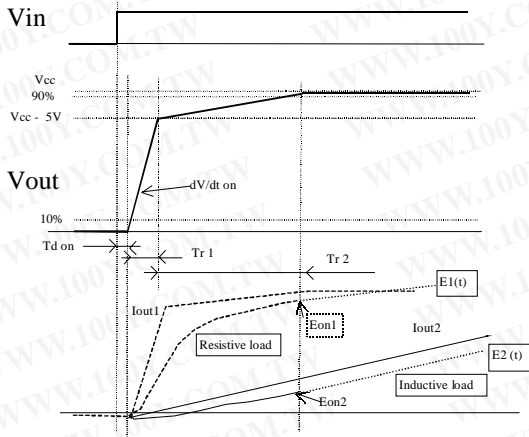

Figure 3 - Switching times definition (turn-on)
 Turn on energy with a resistive or an inductive load

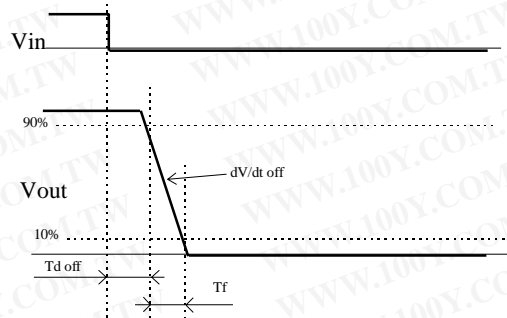

Figure 4 - Switching times definition (turn-off)

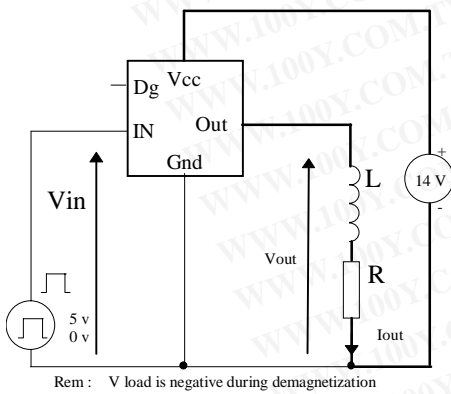

Figure 5 - Active clamp test circuit

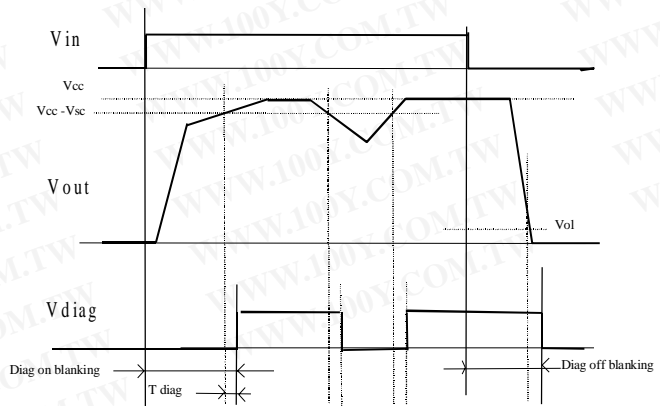

Figure 6 - Diagnostic delay definitions

International
IR Rectifier

IPS511G/IPS512G

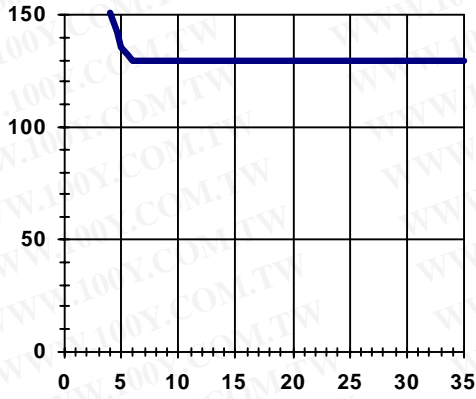

Figure 7 - R_{ds(on)} (mΩ) Vs V_{CC} (V)

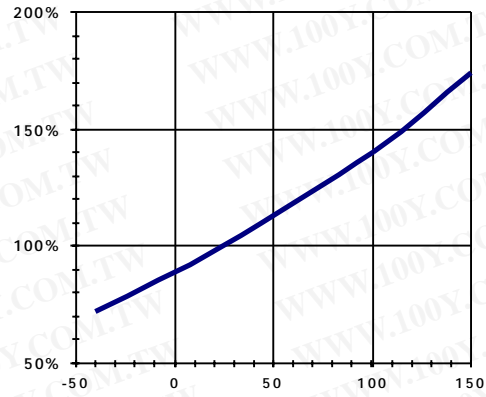

Figure 8 - Normalized R_{ds(on)} Vs T_j (°C)

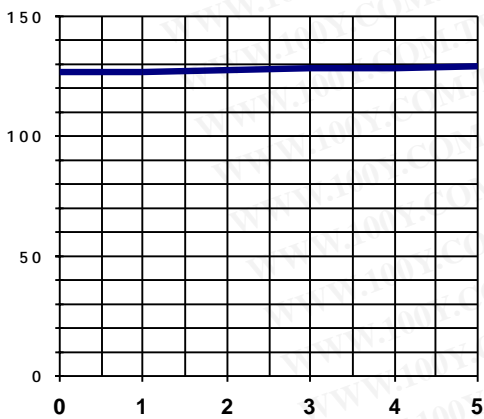

Figure 9 - R_{ds(on)} (mΩ) Vs I_{out} (A)

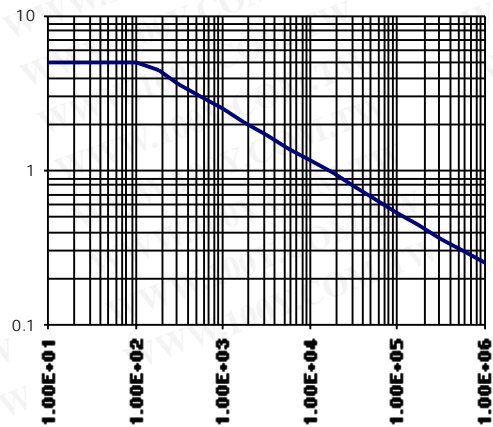

Figure 10 - Max. I_{out} (A) Vs Load Inductance (uH)

勝特力材料 886-3-5753170
 勝特力电子(上海) 86-21-54151736
 勝特力电子(深圳) 86-755-83298787
[Http://www.100y.com.tw](http://www.100y.com.tw)

International
IR Rectifier

IPS511G/IPS512G

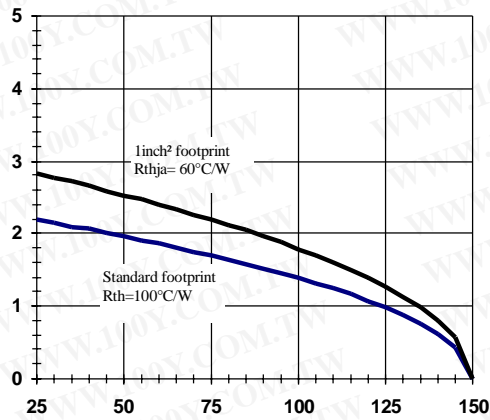

Figure 11a - Max load current (A) Vs Tamb (°C)
IPS511G

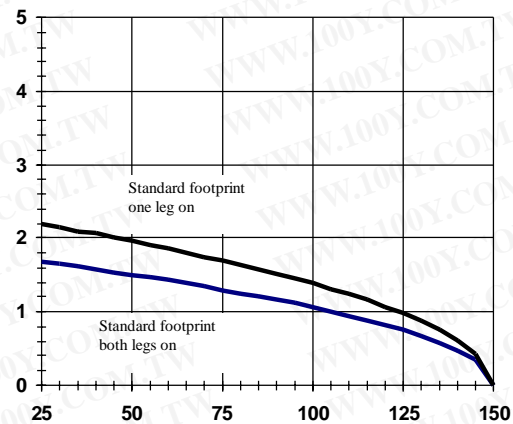

Figure 11b - Max load current (A) Vs Tamb (°C)
IPS512G

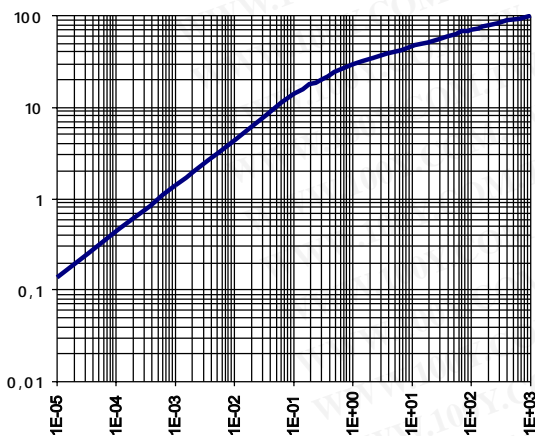

Figure 12 - Transient Thermal Impedance (°C/W)
Vs Time (S) - IPS511G/IPS512G

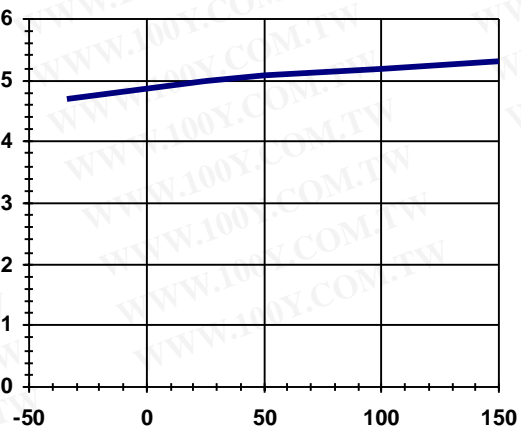

Figure 13 - Ilim (A) Vs Tj (°C)

IPS511G/IPS512G

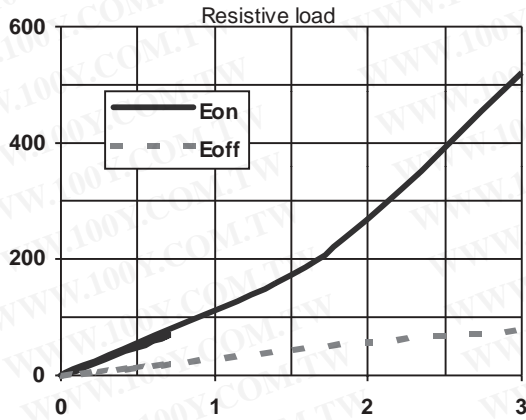

Figure 14 - Eon, Eoff (μJ) vs I (A)

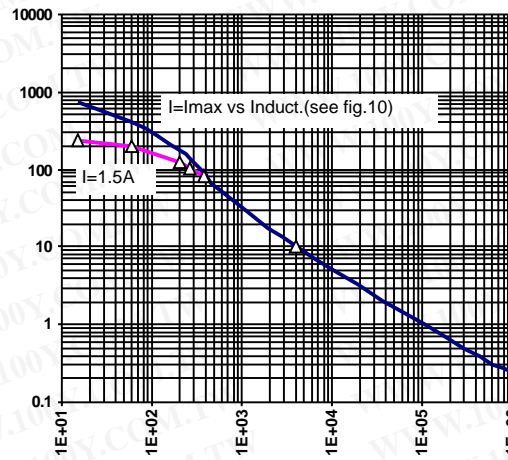

Figure 15 - Eon (μJ) Vs Load Inductance (μH) (see Fig. 3)

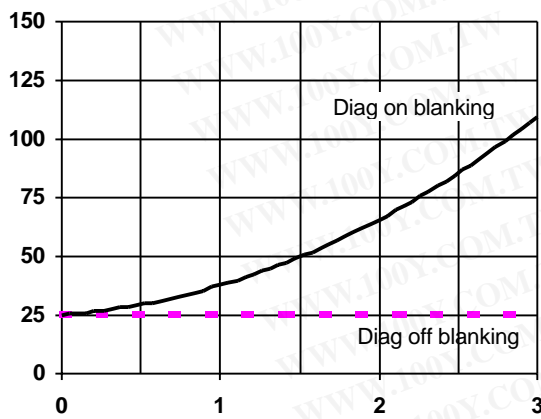

Figure 16 - Diag Blanking time (μs) Vs Iout (A) (resistive load - see Fig. 6)

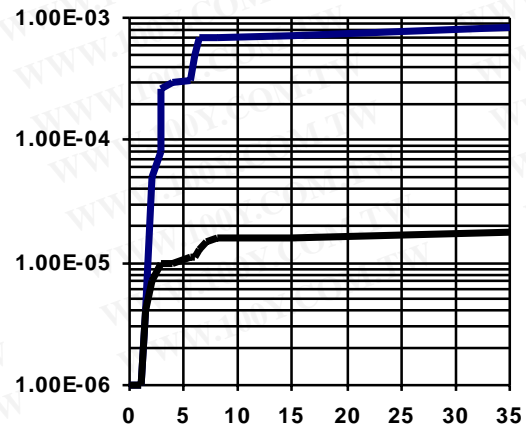
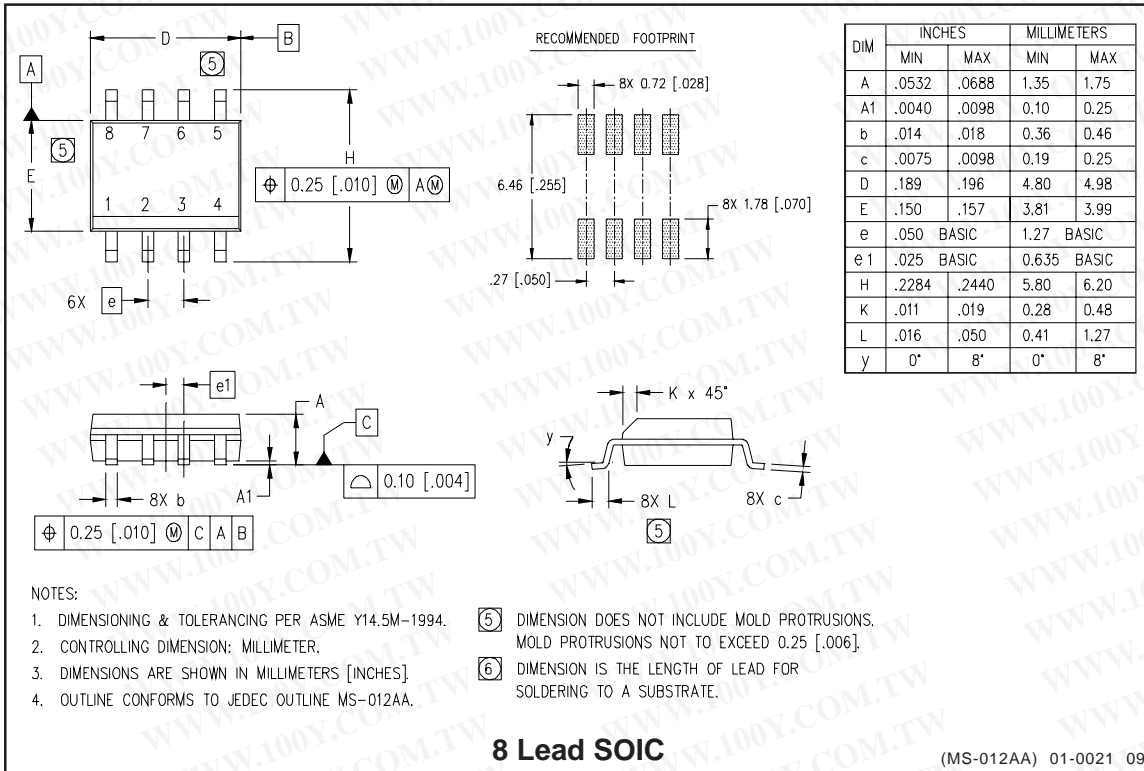

Figure 17 - Icc (mA) Vs Vcc (V)

IPS511G/IPS512G

International
IR Rectifier

Case Outline - IPS511G



IPS511G/IPS512G

Case Outline

