

## SINGLE-SUPPLY DUAL HIGH CURRENT OPERATIONAL AMPLIFIER

### ■ GENERAL DESCRIPTION

The NJM3414A integrated circuit is a high gain, high output current, high output voltage swing dual operational amplifier capable of driving 70mA.

### ■ FEATURES

- Single Supply
- Operating Voltage (+3V~+15V)
- High Output Current (70mA typ.)
- Slew Rate (1.0V/μs typ.)
- Package Outline DIP8, DMP8, SIP8, SSOP8
- Bipolar Technology

### ■ PIN CONFIGURATION

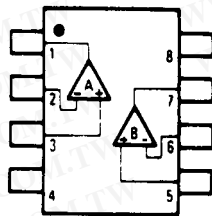

NJM3414AD  
NJM3414AM  
NJM3414AV

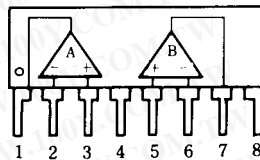

NJM3414AL

### ■ PACKAGE OUTLINE

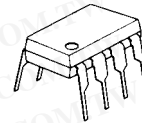

NJM3414AD



NJM3414AM

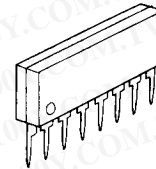

NJM3414AL



NJM3414AV

\* S-Type (SIP9) available

### PIN FUNCTION

- 1.A OUTPUT
- 2.A -INPUT
- 3.A +INPUT
- 4.GND
- 5.B +INPUT
- 6.B -INPUT
- 7.B OUTPUT
- 8.V<sup>+</sup>

### ■ EQUIVALENT CIRCUIT (1/2 Shown)

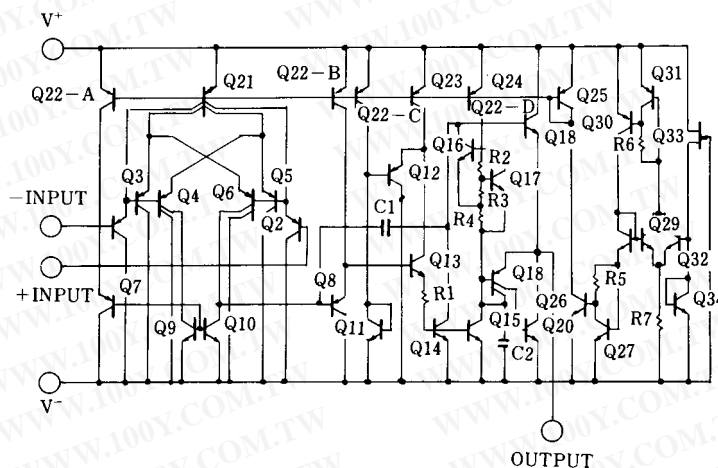

勝特力材料 886-3-5753170  
 勝特力电子(上海) 86-21-54151736  
 勝特力电子(深圳) 86-755-83298787  
[Http://www.100y.com.tw](http://www.100y.com.tw)

# NJM3414A

## ■ ABSOLUTE MAXIMUM RATINGS

(Ta=25°C)

PARAMETER	SYMBOL	RATINGS	UNIT
Supply Voltage	$V^+(V^+V^-)$	15V (or $\pm 7.5$ )	V
Differential Input Voltage	$V_{ID}$	15	V
Input Voltage	$V_{IC}$	-0.3~+15	V
Power Dissipation	$P_D$	(DIP8) 500 (DMP8) 300 (SSOP8) 250 (SIP8) 800	mW
Operating Temperature Range	$T_{opr}$	-20~+75	°C
Storage Temperature Range	$T_{stg}$	-40~+125	°C

## ■ ELECTRICAL CHARACTERISTICS

(Ta=25°C,  $V^+=8.6V$ )

PARAMETER	SYMBOL	TEST CONDITION	MIN.	TYP.	MAX.	UNIT
Input Offset Voltage	$V_{IO}$	$R_S=0\Omega$	-	2	5	mV
Input Offset Current	$I_{IO}$		-	5	100	nA
Input Bias Current	$I_B$		-	100	500	nA
Large Signal Voltage Gain	$A_V$	$R_L=2k\Omega$	88	100	-	dB
Input Common Voltage Range	$V_{ICM}$		$V^+-2$	-	-	V
Maximum Output Voltage Swing 1	$V_{OM1}$	$R_L \geq 2k\Omega, V^+=5V$	3.5	-	-	V
Maximum Output Voltage Swing 2	$V_{OM2}$	$I_O=70mA, V^+=5V$	3.2	-	-	V
Common Mode Rejection Ratio	CMR		80	90	-	dB
Supply Voltage Rejection Ratio	SVR		80	90	-	dB
Operating Current	$I_{CC}$	$R_L=\infty$	3	4	5	mA
Slew Rate	SR		-	1.0	-	V/ $\mu$ s
Gain Bandwidth Product	GB		-	1.3	-	MHz
Operating Voltage Range	$V^+$		-	-	15	V

勝特力材料 886-3-5753170  
 勝特力电子(上海) 86-21-54151736  
 勝特力电子(深圳) 86-755-83298787  
[Http://www.100y.com.tw](http://www.100y.com.tw)

## ■ TYPICAL CHARACTERISTICS

### Output Source Current vs. $V_{sat}^+$

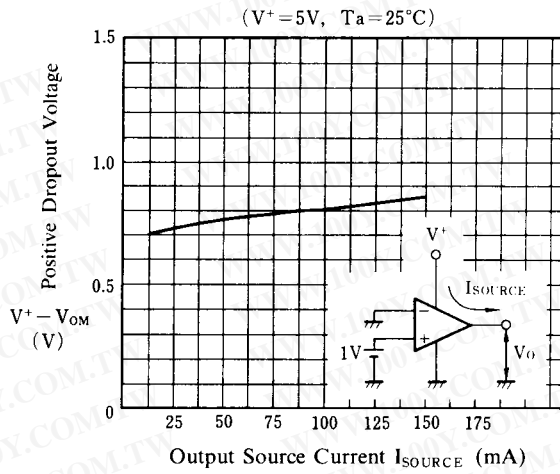

### Output Sink Current vs. $V_{sat}$

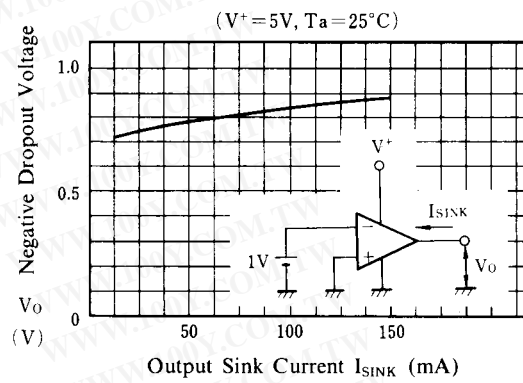

### Input Offset Voltage vs. Temperature

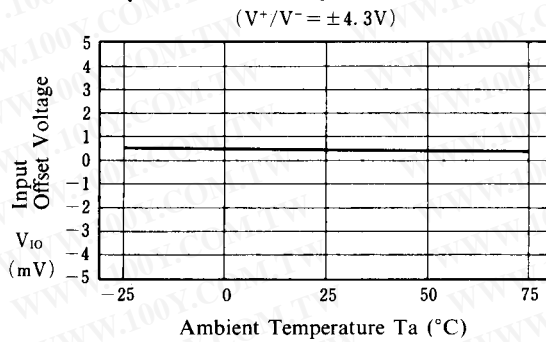

### Input Bias Current vs. Temperature

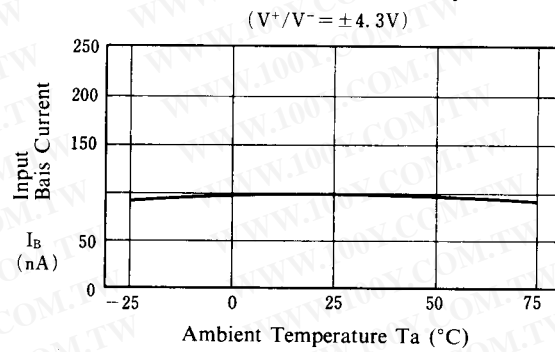

### Operating Voltage vs. Operating Current

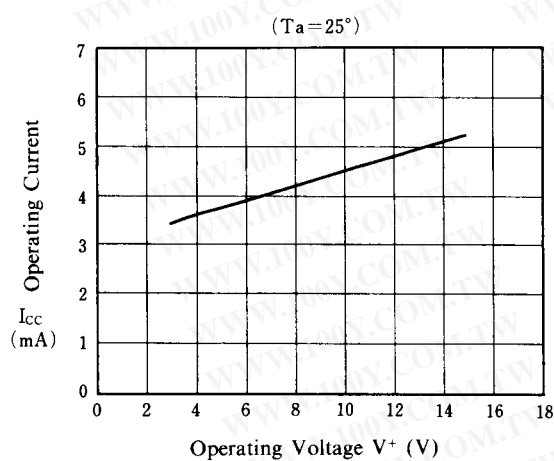

### Maximum Output Voltage Swing 2 vs. Temperature

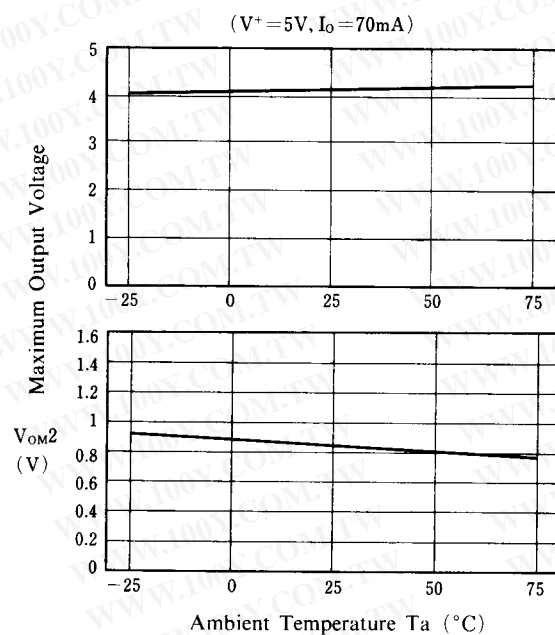

勝特力材料 886-3-5753170  
 勝特力电子(上海) 86-21-54151736  
 勝特力电子(深圳) 86-755-83298787  
[Http://www.100y.com.tw](http://www.100y.com.tw)

# NJM3414A

## TYPICAL CHARACTERISTICS

**Maximum Output Voltage vs. Operating Voltage**

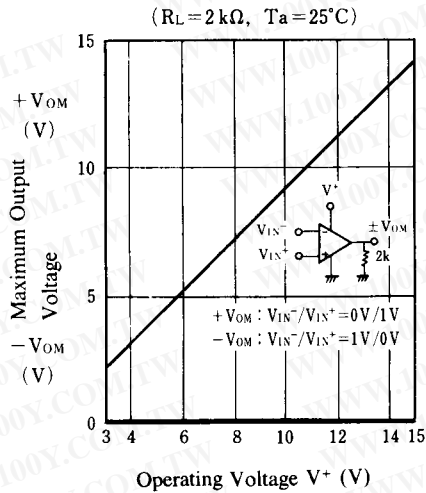

**Maximum Output Voltage vs. Load Resistance**

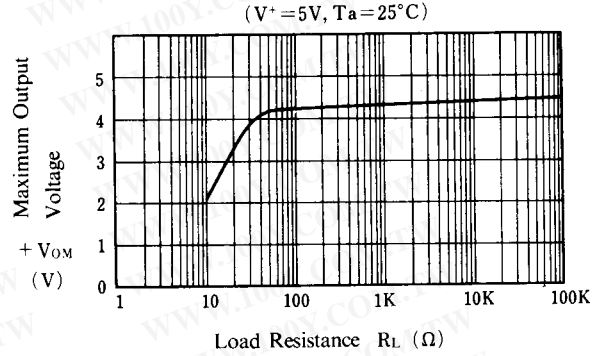

勝特力材料 886-3-5753170  
 勝特力电子(上海) 86-21-54151736  
 勝特力电子(深圳) 86-755-83298787  
[Http://www.100y.com.tw](http://www.100y.com.tw)

**Maximum Output Voltage vs. Frequency**

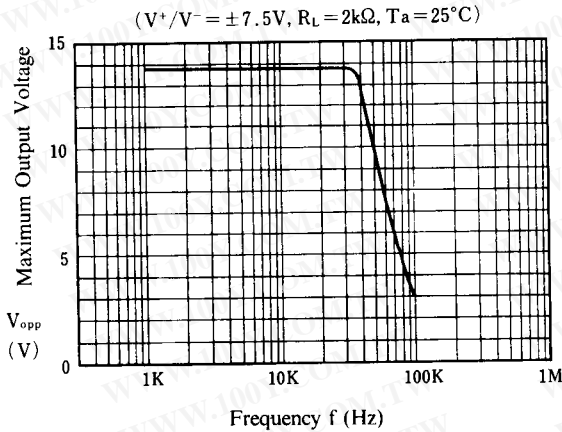

**Voltage Gain, Phase vs. Frequency**

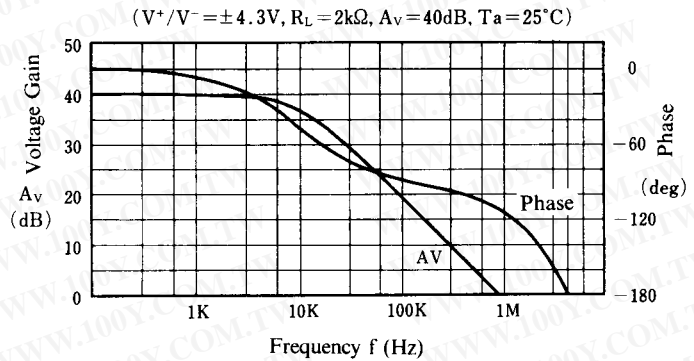

**Operating Current vs. Temperature**

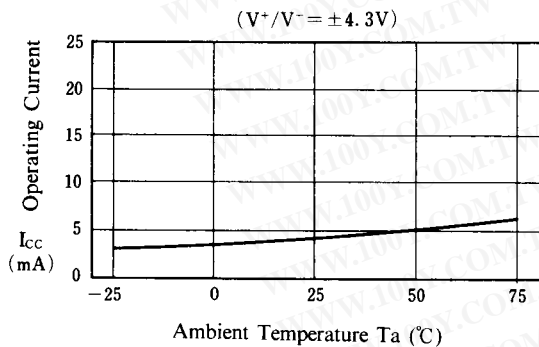

**Maximum Output Voltage vs. Temperature**

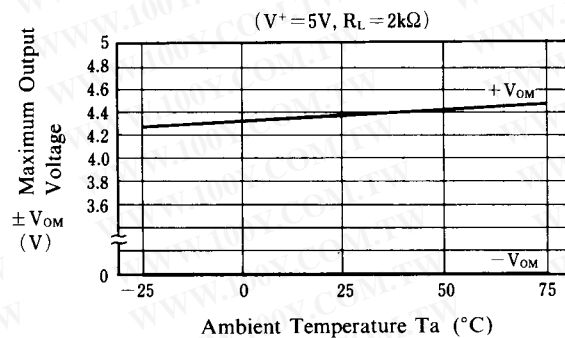

**DIP8**

勝特力材料 886-3-5753170  
 勝特力电子(上海) 86-21-54151736  
 勝特力电子(深圳) 86-755-83298787  
[Http://www.100y.com.tw](http://www.100y.com.tw)

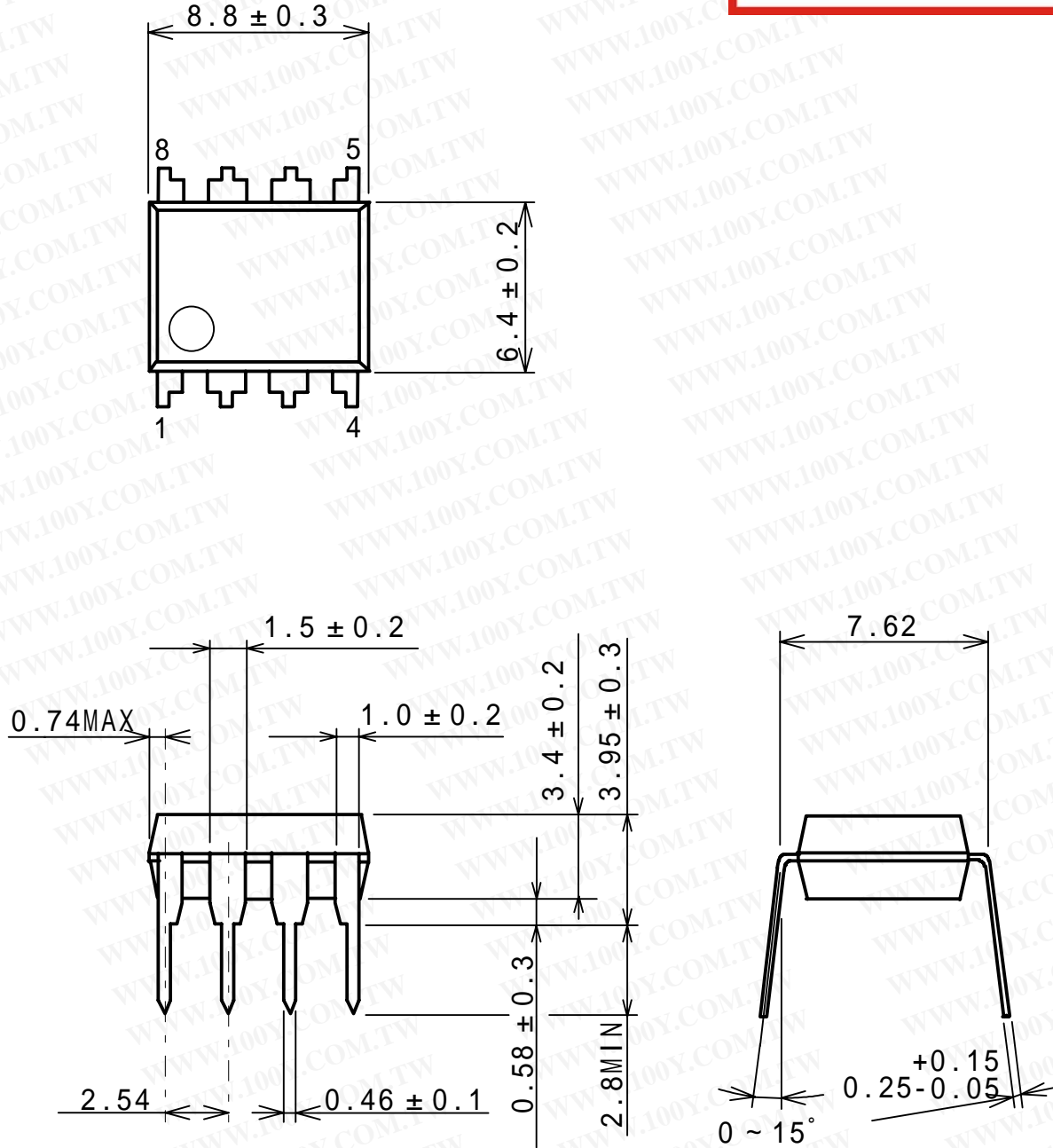

UNIT : mm

**DMP8**

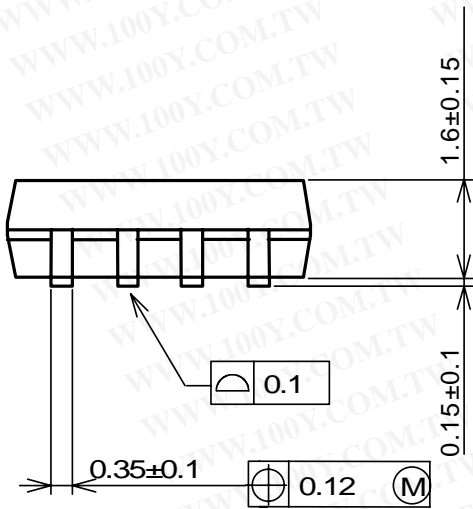
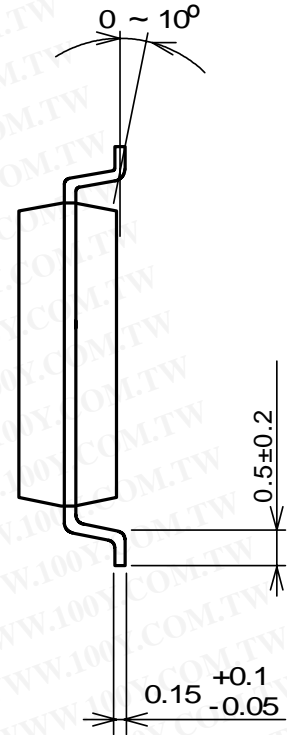
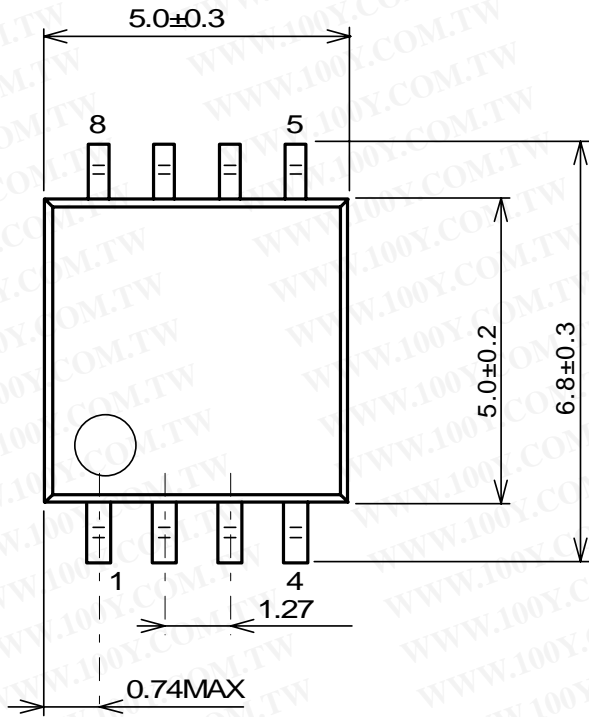

勝特力材料 886-3-5753170  
 勝特力电子(上海) 86-21-54151736  
 勝特力电子(深圳) 86-755-83298787  
[Http://www.100y.com.tw](http://www.100y.com.tw)

UNIT : mm

SIP8

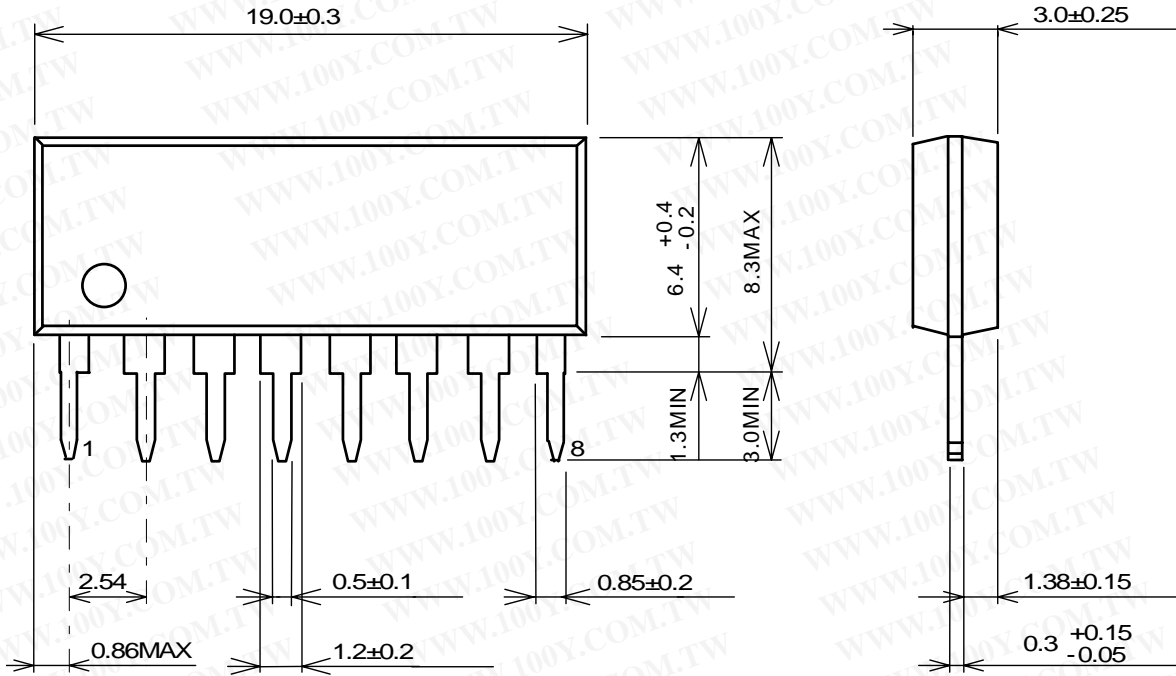

勝特力材料 886-3-5753170  
 勝特力电子(上海) 86-21-54151736  
 勝特力电子(深圳) 86-755-83298787  
[Http://www.100y.com.tw](http://www.100y.com.tw)

UNIT : mm

## SSOP8

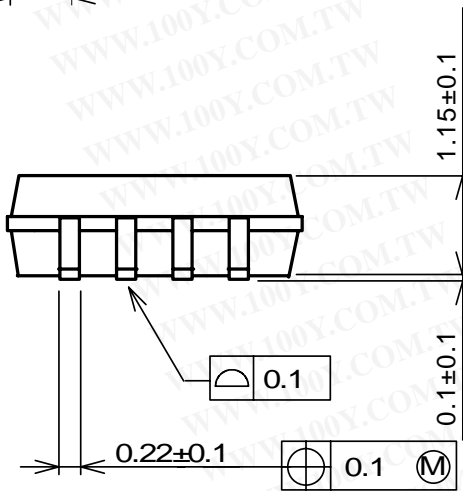
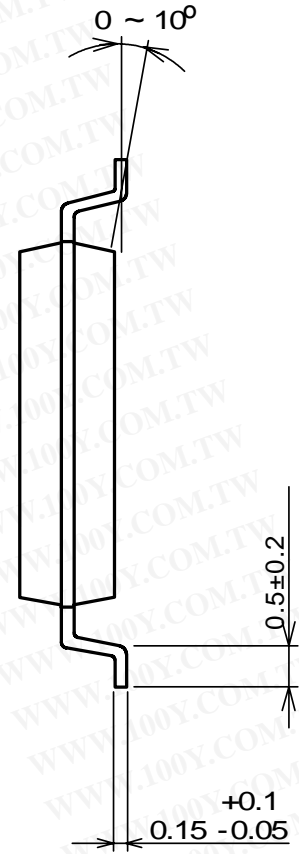
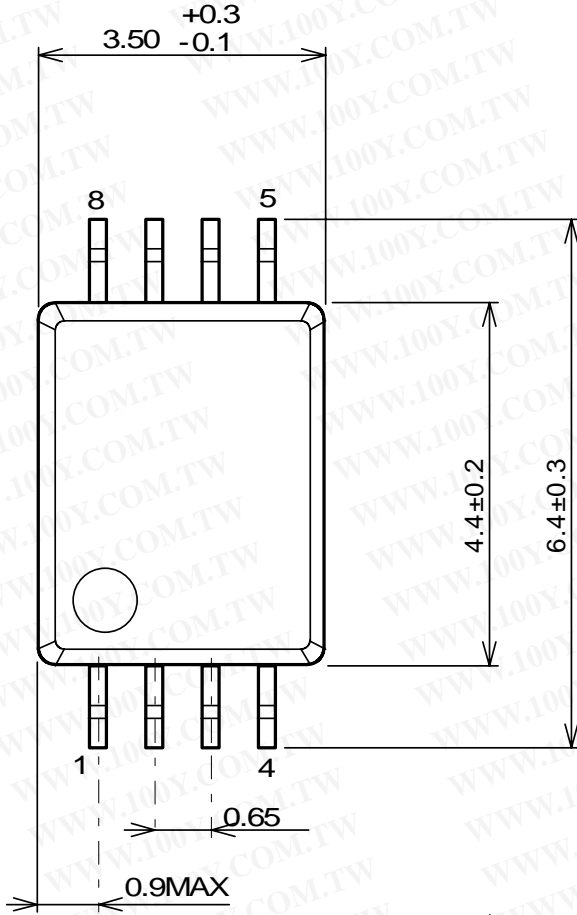

勝特力材料 886-3-5753170  
 勝特力电子(上海) 86-21-54151736  
 勝特力电子(深圳) 86-755-83298787  
[Http://www.100y.com.tw](http://www.100y.com.tw)

UNIT : mm