

KA79LXXA

3-Terminal 0.1A Negative Voltage Regulator

Features

- Output Current up to 100mA
- No External Components
- Internal Thermal Over Load Protection
- Internal Short Circuit Current Limiting
- Output Voltage Offered in $\pm 5\%$ Tolerance
- Output Voltage of -5V, -8V, -12V, -15V, -18V and -24V

Description

These regulators employ internal current limiting and thermal shutdown, making them essentially indestructible.

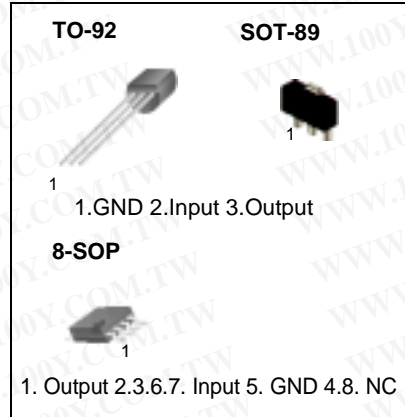

Internal Block Diagram

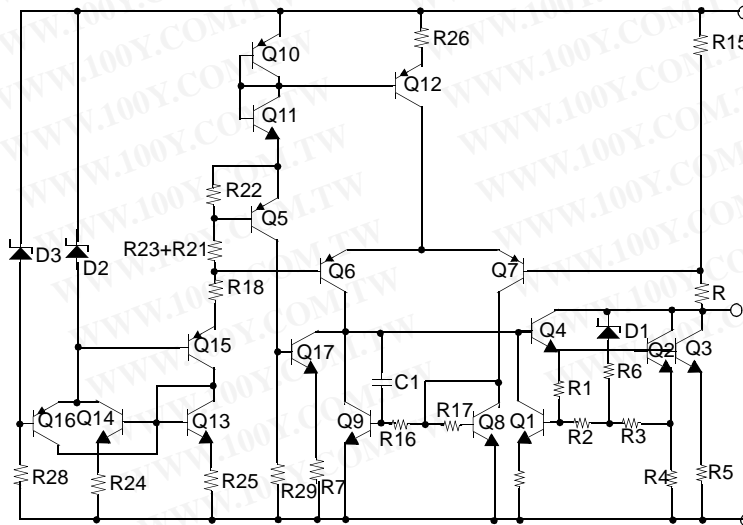

Absolute Maximum Ratings

Parameter	Symbol	Value	Unit
Input Voltage (for $V_O = -5V$ to $-8V$) (for $V_O = -12V$ to $-18V$) (for $V_O = -24V$)	V_I	-30 -35 -40	V
Operating Temperature Range	TOPR	0 ~ +125	°C
Storage Temperature Range	TSTG	-65 ~ +150	°C

Electrical Characteristics(KA79L05A)

($V_I = -10V$, $I_O = 40mA$, $C_I = 0.33\mu F$, $C_O = 0.1\mu F$, $0^\circ C \leq T_J \leq +125^\circ C$, unless otherwise specified)

Parameter	Symbol	Conditions	Min.	Typ.	Max.	Unit	
Output Voltage	V_O	$T_J = +25^\circ C$	-4.8	-5.0	-5.2	V	
Line Regulation (Note1)	ΔV_O	$T_J = +25^\circ C$	$-7.0V \geq V_I \geq -20V$	-	15	150	mV
			$-8V \geq V_I \geq -20V$	-	-	100	mV
Load Regulation (Note1)	ΔV_O	$T_J = +25^\circ C$	$1.0mA \leq I_O \leq 100mA$	-	20	60	mV
			$1.0mA \leq I_O \leq 40mA$	-	10	30	mV
Output Voltage	V_O	$-7.0V \geq V_I \geq -20V$, $1.0mA \leq I_O \leq 40mA$	-4.75	-	-5.25	V	
		$V_I = -10V$, $1.0mA \leq I_O \leq 70mA$	-4.75	-	-5.25	V	
Quiescent Current	I_Q	$T_J = +25^\circ C$	-	2.0	5.5	mA	
		$T_J = +125^\circ C$	-	-	6.0		
Quiescent Current Change	With Line	ΔI_Q	-	-	1.5	mA	
	With Load	ΔI_Q	-	-	0.1	mA	
Output Noise Voltage	V_N	$T_A = +25^\circ C$, $10Hz \leq f \leq 100kHz$	-	30	-	μV	
Ripple Rejection	RR	$f = 120Hz$, $-8V \geq V_I \geq -18V$, $T_J = +25^\circ C$	41	60	-	dB	
Dropout Voltage	V_D	$T_J = +25^\circ C$	-	1.7	-	V	

Note

1. Load and line regulation are specified at constant junction temperature. Change in V_O due to heating effects must be taken into account separately. Pulse testing with low duty is used.

Electrical Characteristics (KA79L08A) (Continued)

($V_I = -14V$, $I_O = 40mA$, $C_I = 0.33\mu F$, $C_O = 0.1\mu F$, $0^\circ C \leq T_J \leq +125^\circ C$, unless otherwise specified)

Parameter	Symbol	Conditions	Min.	Typ.	Max.	Unit	
Output Voltage	V_O	$T_J = +25^\circ C$	-7.7	-8.0	-8.3	V	
Line Regulation (Note1)	ΔV_O	$T_J = +25^\circ C$	$-10.3V \geq V_I \geq -23V$	-	-	175	mV
			$-12V \geq V_I \geq -23V$	-	-	125	mV
Load Regulation (Note1)	ΔV_O	$T_J = +25^\circ C$	$1.0mA \leq I_O \leq 100mA$	-	-	80	mV
			$1.0mA \leq I_O \leq 40mA$	-	-	40	mV
Output Voltage	V_O	$-10.3V \geq V_I \geq -23V$, $1.0mA \leq I_O \leq 40mA$	-7.6	-	-8.4	V	
		$V_I = -14V$, $1.0mA \leq I_O \leq 70mA$	-7.6	-	-8.4		
Quiescent Current	I_Q	$T_J = +25^\circ C$	-	-	6.0	mA	
		$T_J = +125^\circ C$	-	-	5.5		
Quiescent Current Change	With Line	ΔI_Q	$-11.7V \geq V_I \geq -23V$	-	-	1.5	mA
	With Load		$1.0mA \leq I_O \leq 40mA$	-	-	0.1	mA
Output Noise Voltage	V_N	$T_J = +25^\circ C$, $10Hz \leq f \leq 100kHz$	-	50	-	μV	
Ripple Rejection	RR	$f = 120Hz$, $-11V \geq V_I \geq -21V$, $T_J = +25^\circ C$	39	55	-	dB	
Dropout Voltage	V_D	$T_J = +25^\circ C$	-	1.7	-	V	

Note

1. Load and line regulation are specified at constant junction temperature. Change in V_O due to heating effects must be taken into account separately. Pulse testing with low duty is used.

Electrical Characteristics(KA79L12A) (Continued)

($V_I = -19V$, $I_O = 40mA$, $C_I = 0.33\mu F$, $C_O = 0.1\mu F$, $0^\circ C \leq T_J \leq +125^\circ C$, unless otherwise specified)

Parameter	Symbol	Conditions	Min.	Typ.	Max.	Unit	
Output Voltage	V_O	$T_J = +25^\circ C$	-11.5	-12.0	-12.5	V	
Line Regulation (Note1)	ΔV_O	$T_J = +25^\circ C$	$-14.5V \geq V_I \geq -27V$	-	-	250	mV
			$-16V \geq V_I \geq -27V$	-	-	200	mV
Load Regulation (Note1)	ΔV_O	$T_J = +25^\circ C$	$1.0mA \leq I_O \leq 100mA$	-	-	100	mV
			$1.0mA \leq I_O \leq 40mA$	-	-	50	mV
Output Voltage	V_O	$-14.5V > V_I > -27V$, $1.0mA \leq I_O \leq 40mA$	-11.4	-	-12.6	V	
		$V_I = -19V$, $1.0mA \leq I_O \leq 70mA$	-11.4	-	-12.6	V	
Quiescent Current	I_Q	$T_J = +25^\circ C$	-	-	6.0	mA	
		$T_J = +125^\circ C$	-	-	6.5		
Quiescent Current Change	With Line	ΔI_Q	$-16V \geq V_I \geq -27V$	-	-	1.5	mA
	With Load	ΔI_Q	$1.0mA \leq I_O \leq 40mA$	-	-	0.1	mA
Output Noise Voltage	V_N	$T_A = +25^\circ C$, $10Hz \leq f \leq 100kHz$	-	80	-	μV	
Ripple Rejection	RR	$f = 120Hz$, $-15V \geq V_I \geq -25V$ $T_J = +25^\circ C$	37	42	-	dB	
Dropout Voltage	V_D	$T_J = +25^\circ C$	-	1.7	-	V	

Note

1. Load and line regulation are specified at constant junction temperature. Change in V_O due to heating effects must be taken into account separately. Pulse testing with low duty is used.

Electrical Characteristics(KA79L15A) (Continued)

($V_I = -23V$, $I_O = 40mA$, $C_I = 0.33\mu F$, $C_O = 0.1\mu F$, $0^\circ C \leq T_J \leq +125^\circ C$, unless otherwise specified)

Parameter	Symbol	Conditions	Min.	Typ.	Max.	Unit	
Output Voltage	V_O	$T_J = +25^\circ C$	-14.4	-15.0	-15.6	V	
Line Regulation (Note1)	ΔV_O	$T_J = +25^\circ C$	$-17.5V \geq V_I \geq -30V$	-	-	300	mV
			$-20V \geq V_I \geq -30V$	-	-	250	mV
Load Regulation (Note1)	ΔV_O	$T_J = +25^\circ C$	$1.0mA \leq I_O \leq 100mA$	-	-	150	mV
			$1.0mA \leq I_O \leq 40mA$	-	-	75	mV
Output Voltage	V_O	$-17.5V \geq V_I \geq -30V$, $1.0mA \leq I_O \leq 40mA$	-14.25	-	-15.75	V	
		$V_I = -23V$, $1.0mA \leq I_O \leq 70mA$	-14.25	-	-15.75	V	
Quiescent Current	I_Q	$T_J = +25^\circ C$	-	-	6.0	mA	
		$T_J = +125^\circ C$	-	-	6.5		
Quiescent Current Change	With Line	ΔI_Q	-20V $\geq V_I \geq -30V$	-	-	1.5	mA
	With Load	ΔI_Q	$1.0mA \leq I_O \leq 40mA$	-	-	0.1	mA
Output Noise Voltage	V_N	$T_A = +25^\circ C$, $10Hz \leq f \leq 100kHz$	-	90	-	μV	
Ripple Rejection	RR	$f = 120Hz$, $-18.5V \geq V_I \geq -28.5V$ $T_J = +25^\circ C$	34	39	-	dB	
Dropout Voltage	V_D	$T_J = +25^\circ C$	-	1.7	-	V	

Note

1. Load and line regulation are specified at constant junction temperature. Change in V_O due to heating effects must be taken into account separately. Pulse testing with low duty is used.

Electrical Characteristics(KA79L18A) (Continued)

($V_I = -27V$, $I_O = 40mA$, $C_I = 0.33\mu F$, $C_O = 0.1\mu F$, $0^\circ C \leq T_J \leq +125^\circ C$, unless otherwise specified)

Parameter	Symbol	Conditions	Min.	Typ.	Max.	Unit	
Output Voltage	V_O	$T_J = +25^\circ C$	-17.3	-18.0	-18.7	V	
Line Regulation (Note1)	ΔV_O	$T_J = +25^\circ C$	$-20.7V \geq V_I \geq -33V$	-	-	325	mV
			$-21V \geq V_I \geq -33V$	-	-	275	mV
Load Regulation (Note1)	ΔV_O	$T_J = +25^\circ C$	$1.0mA \leq I_O \leq 100mA$	-	-	170	mV
			$1.0mA \leq I_O \leq 40mA$	-	-	85	mV
Output Voltage	V_O	$-20.7V > V_I > -33V$, $1.0mA \leq I_O \leq 40mA$	-17.1	-	-18.9	V	
		$V_I = -27V$, $1.0mA \leq I_O \leq 70mA$	-17.1	-	-18.9	V	
Quiescent Current	I_Q	$T_J = +25^\circ C$	-	-	6.5	mA	
		$T_J = +125^\circ C$	-	-	6.0		
Quiescent Current Change	With Line	ΔI_Q	$-21V \geq V_I \geq -33V$	-	-	1.5	mA
	With Load	ΔI_Q	$1.0mA \leq I_O \leq 40mA$	-	-	0.1	mA
Output Noise Voltage	V_N	$T_A = +25^\circ C$, $10Hz \leq f \leq 100kHz$	-	150	-	μV	
Ripple Rejection	RR	$f = 120Hz$, $-23V \geq V_I \geq -33V$ $T_J = +25^\circ C$	33	48	-	dB	
Dropout Voltage	V_D	$T_J = +25^\circ C$	-	1.7	-	V	

Note

1. Load and line regulation are specified at constant junction temperature. Change in V_O due to heating effects must be taken into account separately. Pulse testing with low duty is used.

Electrical Characteristics(KA79L24A) (Continued)

($V_I = -33V$, $I_O = 40mA$, $C_I = 0.33\mu F$, $C_O = 0.1\mu F$, $0^\circ C \leq T_J \leq +125^\circ C$, unless otherwise specified)

Parameter	Symbol	Conditions	Min.	Typ.	Max.	Unit	
Output Voltage	V_O	$T_J = +25^\circ C$	-23	-24	-25	V	
Line Regulation (Note1)	ΔV_O	$T_J = +25^\circ C$	$-27V \geq V_I \geq -38V$	-	-	350	mV
			$-28V \geq V_I \geq -38V$	-	-	300	mV
Load Regulation (Note1)	ΔV_O	$T_J = +25^\circ C$	$1.0mA \leq I_O \leq 100mA$	-	-	200	mV
			$1.0mA \leq I_O \leq 40mA$	-	-	100	mV
Output Voltage	V_O	$-27V \geq V_I \geq -38V$, $1.0mA \leq I_O \leq 40mA$	-22.8	-	-25.2	V	
		$V_I = -33V$, $1.0mA \leq I_O \leq 70mA$	-22.8	-	-25.2	V	
Quiescent Current	I_Q	$T_J = +25^\circ C$	-	-	6.5	mA	
		$T_J = +125^\circ C$	-	-	6.0		
Quiescent Current Change	With Line	ΔI_Q	$-28V \geq V_I \geq -38V$	-	-	1.5	mA
	With Load	ΔI_Q	$1.0mA \leq I_O \leq 40mA$	-	-	0.1	mA
Output Noise Voltage	V_N	$T_A = +25^\circ C$, $10Hz \leq f \leq 100kHz$	-	200	-	μV	
Ripple Rejection	RR	$f = 120Hz$, $-29V \geq V_I \geq -35V$ $T_J = +25^\circ C$	31	47	-	dB	
Dropout Voltage	V_D	$T_J = +25^\circ C$	-	1.7	-	V	

Note

1. Load and line regulation are specified at constant junction temperature. Change in V_O due to heating effects must be taken into account separately. Pulse testing with low duty is used.

Typical Application

Design Considerations

The KA79LXXA Series of fixed voltage regulators are designed with Thermal Overload Protection that shuts down the circuit when subjected to an excessive power overload condition. Internal Short Circuit Protection that limits the maximum current the circuit will pass. In many low current applications, compensation capacitors are not required. However, it is recommended that the regulator input be bypassed with a capacitor if the regulator is connected to the power supply filter with long wire lengths, or if the output load capacitance is large. An input bypass capacitor should be selected to provide good high frequency characteristics to insure stable operation under all load conditions. A $0.33\mu\text{F}$ or larger tantalum, mylar, or other capacitor having low internal impedance at high frequencies should be chosen. The bypass capacitor should be mounted with the shortest possible leads directly across the regulator's input terminals. Normally good construction techniques should be used to minimize ground loops and lead resistance drops since the regulator has no external sense lead. Bypassing the output is also recommended.

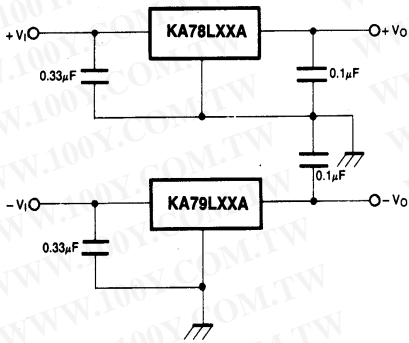

Figure 1. Positive And Negative Regulator

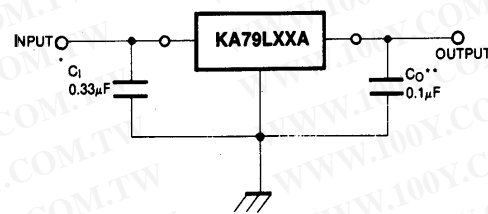

Figure 2. Typical Application

A common ground is required between the input and the output voltages. The input voltage must remain typically 2.0V above the output voltage even during the low point on the input ripple voltage.

* C_1 is required if regulator is located an appreciable distance from power supply filter.

* C_0 improves stability and transient response.

Mechanical Dimensions

Package

Dimensions in millimeters

TO-92

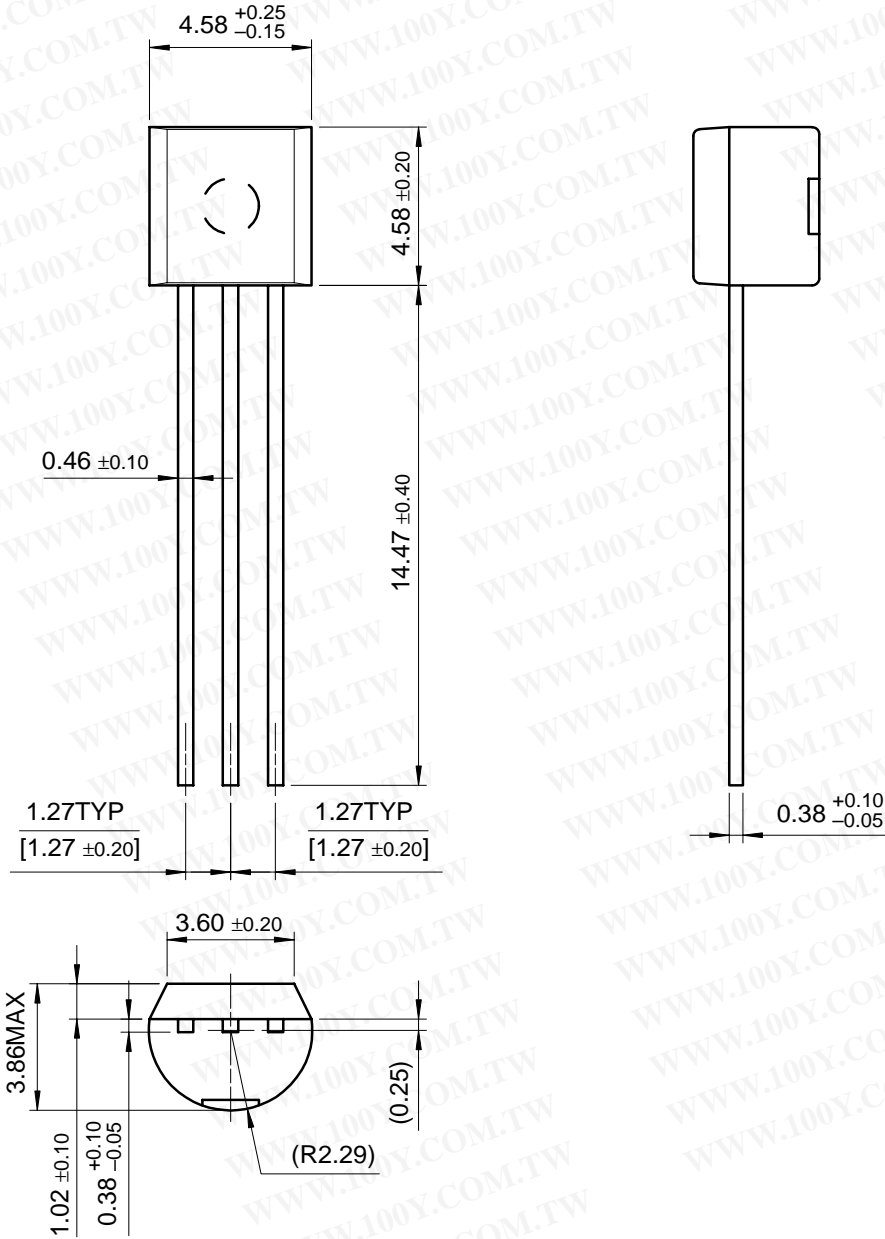

Mechanical Dimensions (Continued)

Package

Dimensions in millimeters

8-SOP

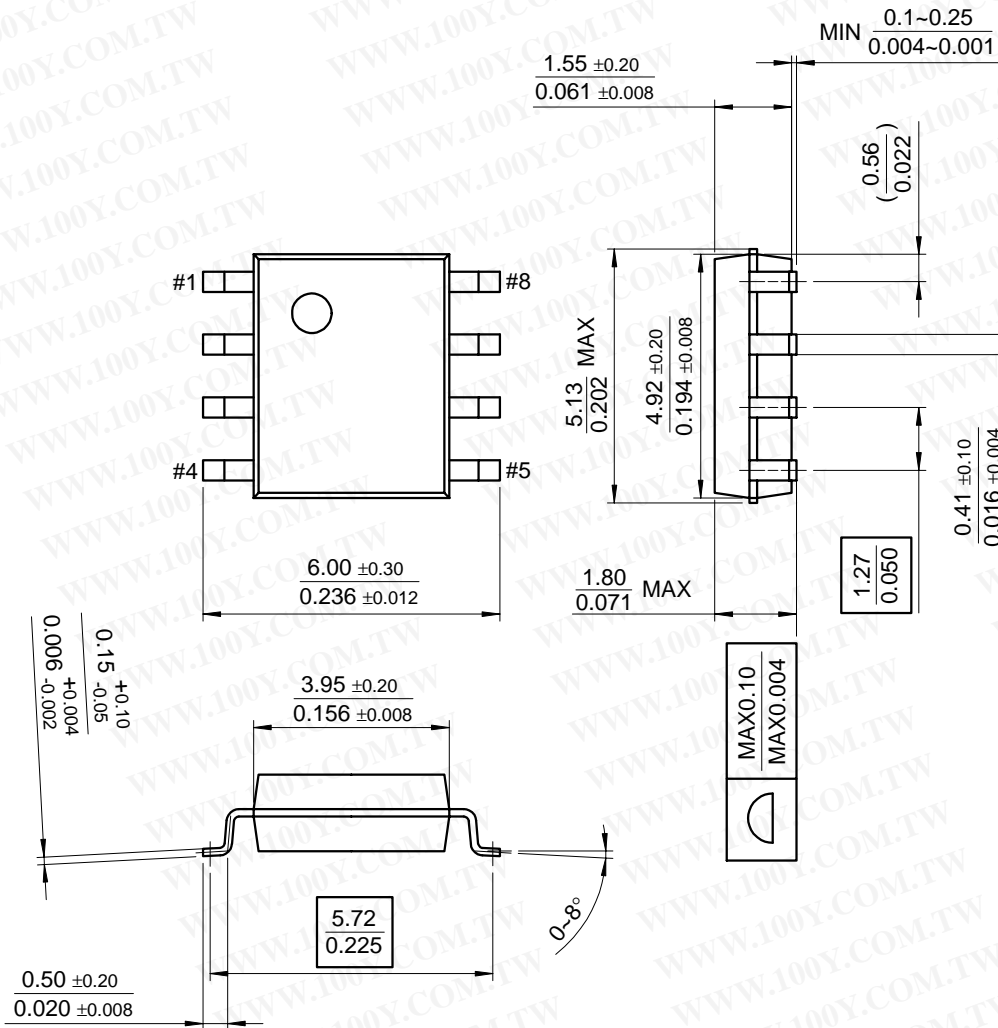

Mechanical Dimensions (Continued)

Package

Dimensions in millimeters

SOT-89

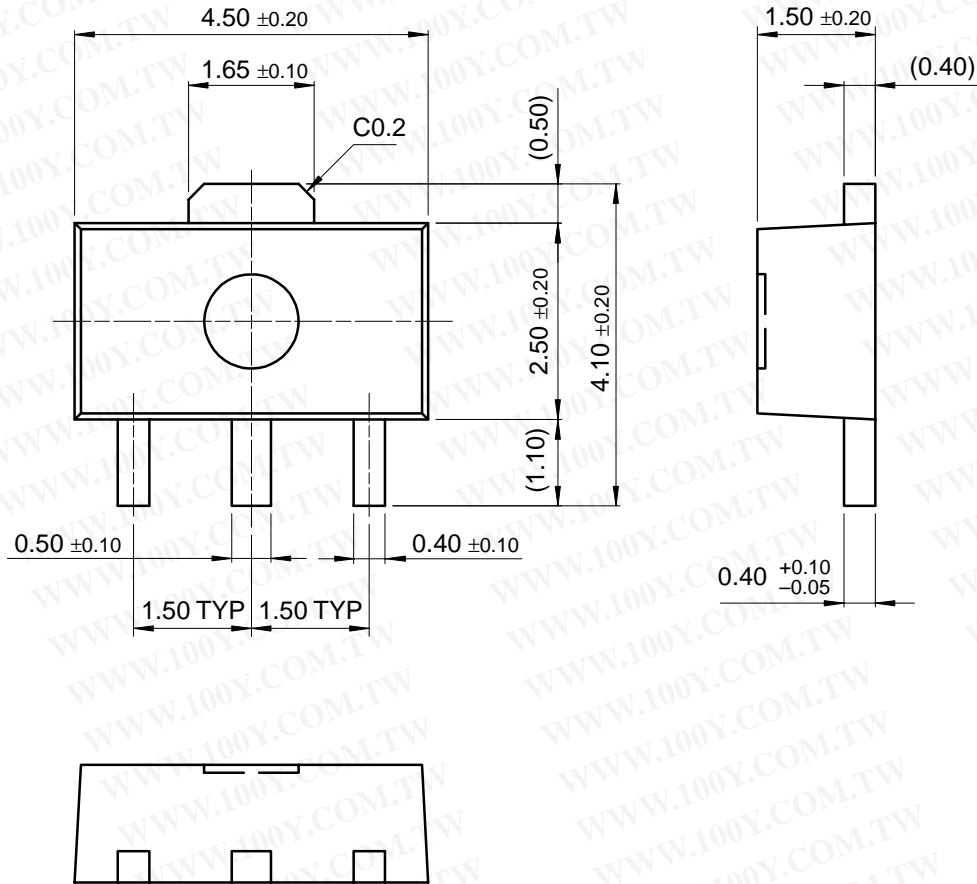

KA79LXXA

勝特力材料 886-3-5753170
勝特力电子(上海) 86-21-54151736
勝特力电子(深圳) 86-755-83298787
[Http://www.100y.com.tw](http://www.100y.com.tw)

Ordering Information

Product Number	Package	Operating Temperature
KA79L05AZ	TO-92	0 ~ +125°C
KA79L08AZ		
KA79L12AZ		
KA79L15AZ		
KA79L18AZ		
KA79L24AZ		
KA79L05AD	8-SOP	
KA79L05AM	SOT-89	