

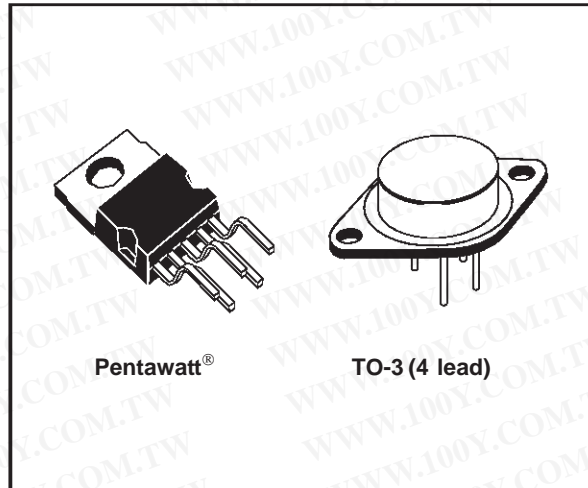

**L200**

## ADJUSTABLE VOLTAGE AND CURRENT REGULATOR

- ADJUSTABLE OUTPUT CURRENT UP TO 2 A (GUARANTEED UP TO  $T_j = 150^\circ\text{C}$ )
- ADJUSTABLE OUTPUT VOLTAGE DOWN TO 2.85 V
- INPUT OVERVOLTAGE PROTECTION (UP TO 60 V, 10 ms)
- SHORT CIRCUIT PROTECTION
- OUTPUT TRANSISTOR S.O.A. PROTECTION
- THERMAL OVERLOAD PROTECTION
- LOW BIAS CURRENT ON REGULATION PIN
- LOW STANDBY CURRENT DRAIN



### DESCRIPTION

The L200 is a monolithic integrated circuit for voltage and current programmable regulation. It is available in Pentawatt® package or 4-lead TO-3 metal case. Current limiting, power limiting, thermal shutdown and input overvoltage protection (up to

60 V) make the L200 virtually blow-out proof. The L200 can be used to replace fixed voltage regulators when high output voltage precision is required and eliminates the need to stock a range of fixed voltage regulators.

### ABSOLUTE MAXIMUM RATINGS

Symbol	Parameter	Value	Unit
$V_i$	DC Input Voltage	40	V
$V_i$	Peak Input Voltage (10 ms)	60	V
$\Delta V_{i-o}$	Dropout Voltage	32	V
$I_o$	Output Current	internally limited	
$P_{tot}$	Power Dissipation	internally limited	
$T_{stg}$	Storage Temperature	-55 to 150	$^\circ\text{C}$
$T_{op}$	Operating Junction Temperature for L200C	-25 to 150	$^\circ\text{C}$
	for L200	-55 to 150	$^\circ\text{C}$

### THERMAL DATA

			TO-3	Pentawatt®
$R_{th\ j-case}$	Thermal Resistance Junction-case	Max	4 $^\circ\text{C}/\text{W}$	3 $^\circ\text{C}/\text{W}$
$R_{th\ j-amb}$	Thermal Resistance Junction-ambient	Max	35 $^\circ\text{C}/\text{W}$	50 $^\circ\text{C}/\text{W}$

## L200

### CONNECTION DIAGRAMS AND ORDER CODES (top views)

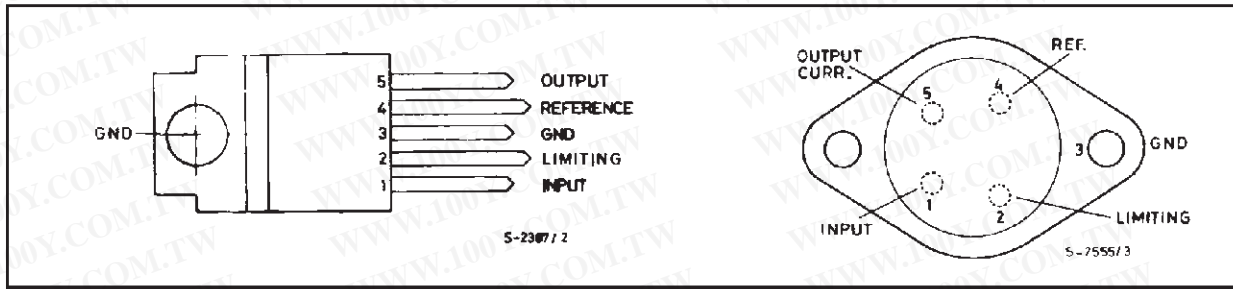

Type	Pentawatt®	TO-3
L200		L200 T
L200 C	L200 CH L200 CV	L200 CT

### BLOCK DIAGRAM

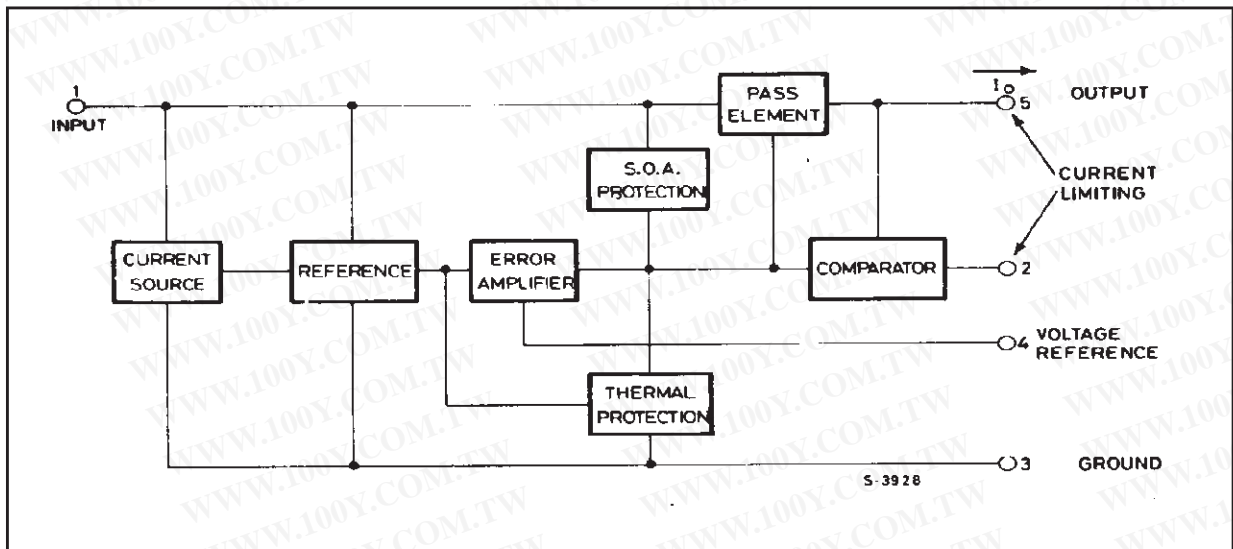

### APPLICATION CIRCUITS

Figure 1. Programmable Voltage Regulator with Current Limiting

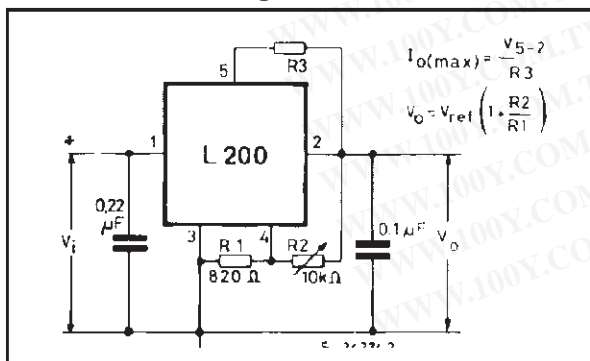
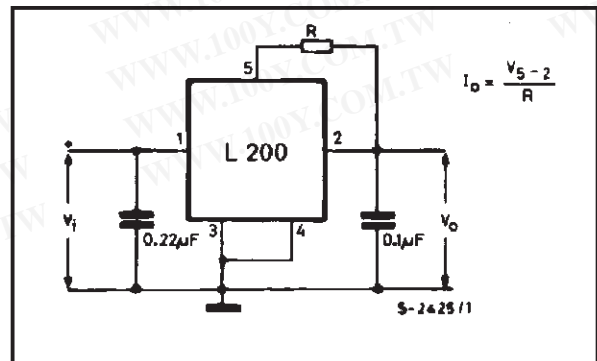
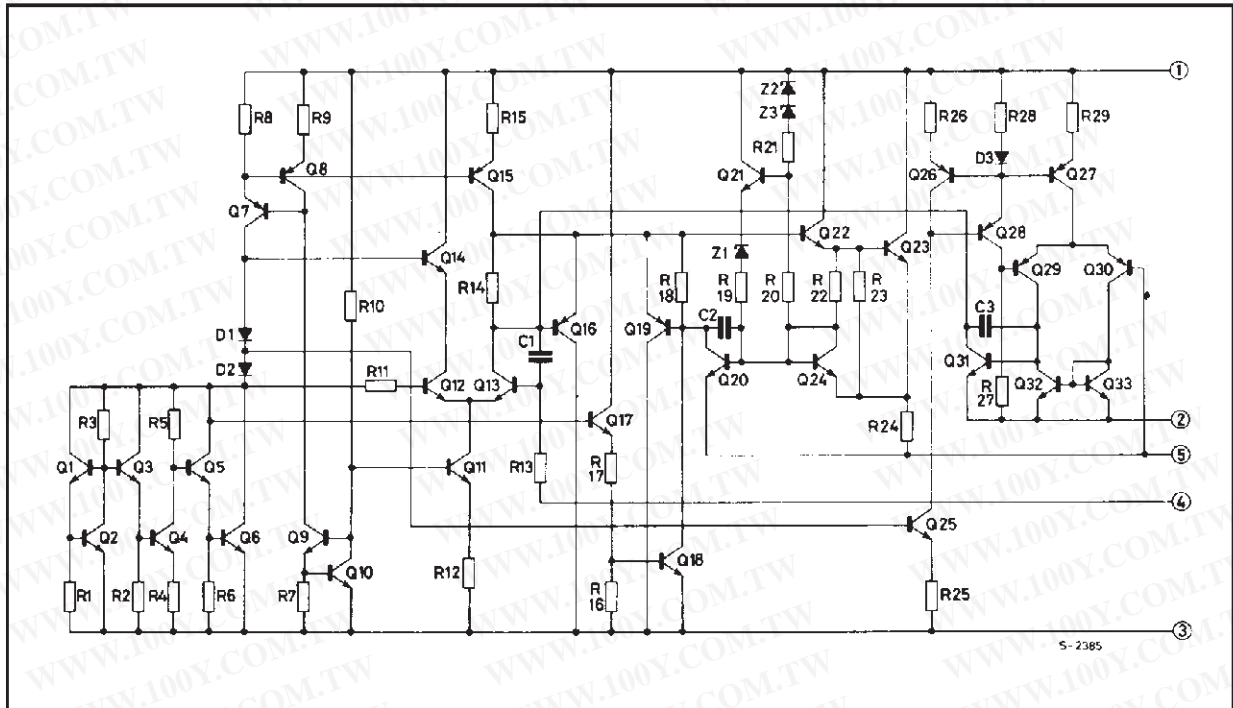

Figure 2. Programmable Current Regulator.



**SCHEMATIC DIAGRAM**



**ELECTRICAL CHARACTERISTICS** ( $T_{amb} = 25\text{ }^{\circ}\text{C}$ , unless otherwise specified)

Symbol	Parameter	Test Conditions	Min.	Typ.	Max.	Unit
--------	-----------	-----------------	------	------	------	------

**VOLTAGE REGULATION LOOP**

$I_d$	Quiescent drain Current (pin 3)	$V_i = 20\text{ V}$		4.2	9.2	mA
$e_N$	Output Noise Voltage	$V_o = V_{ref}$ $B = 1\text{ MHz}$ $I_o = 10\text{ mA}$		80		$\mu\text{V}$
$V_o$	Output Voltage Range	$I_o = 10\text{ mA}$	2.85		36	V
$\frac{\Delta V_o}{V_o}$	Voltage Load Regulation (note 1)	$\Delta I_o = 2\text{ A}$ $\Delta I_o = 1.5\text{ A}$		0.15 0.1	1 0.9	% %
$\frac{\Delta V_i}{\Delta V_o}$	Line Regulation	$V_o = 5\text{ V}$ $V_i = 8\text{ to }18\text{ V}$	48	60		dB
SVR	Supply Voltage Rejection	$V_o = 5\text{ V}$ $\Delta V_i = 10\text{ V}_{pp}$ $f = 100\text{ Hz}$ (note 2) $I_o = 500\text{ mA}$	48	60		dB
$\Delta V_{i-o}$	Droput Voltage between Pins 1 and 5	$I_o = 1.5\text{ A}$ $\Delta V_o \leq 2\%$		2	2.5	V
$V_{ref}$	Reference Voltage (pin 4)	$V_i = 20\text{ V}$ $I_o = 10\text{ mA}$	2.64	2.77	2.86	V

**L200**

**ELECTRICAL CHARACTERISTICS (continued)**

Symbol	Parameter	Test Conditions	Min.	Typ.	Max.	Unit
$\Delta V_{ref}$	Average Temperature Coefficient of Reference Voltage	$V_i = 20\text{ V}$ $I_o = 10\text{ mA}$ for $T_j = -25\text{ to }125\text{ }^\circ\text{C}$ for $T_j = 125\text{ to }150\text{ }^\circ\text{C}$		-0.25 -1.5		mV/ $^\circ\text{C}$ mV/ $^\circ\text{C}$
$I_4$	Bias Current and Pin 4			3	10	$\mu\text{A}$
$\frac{\Delta I_4}{\Delta T \cdot I_4}$	Average Temperature Coefficient (pin 4)			-0.5		%/ $^\circ\text{C}$
$Z_o$	Output Impedance	$V_i = 10\text{ V}$ $I_o = 0.5\text{ A}$ $V_o = V_{ref}$ $f = 100\text{ Hz}$		1.5		m $\Omega$

**CURRENT REGULATION LOOP**

$V_{sc}$	Current Limit Sense Voltage between Pins 5 and 2	$V_i = 10\text{ V}$ $I_5 = 100\text{ mA}$ $V_o = V_{ref}$	0.38	0.45	0.52	V
$\frac{\Delta V_{sc}}{\Delta T \cdot V_{sc}}$	Average Temperature Coefficient of $V_{sc}$			0.03		%/ $^\circ\text{C}$
$\frac{\Delta I_o}{I_o}$	Current Load Regulation	$V_i = 10\text{ V}$ $I_o = 0.5\text{ A}$ $I_o = 1\text{ A}$ $I_o = 1.5\text{ A}$ $\Delta V_o = 3\text{ V}$		1.4 1 0.9		% % %
$I_{sc}$	Peak Short Circuit Current	$V_i - V_o = 14\text{ V}$ (pins 2 and 5 short circuited)			3.6	A

Note 1: A load step of 2 A can be applied provided that input-output differential voltage is lower than 20 V (see Figure 3).

Note 2: The same performance can be maintained at higher output levels if a bypassing capacitor is provided between pins 2 and 4.

**Figure 3. Typical Safe Operating Area Protection.**

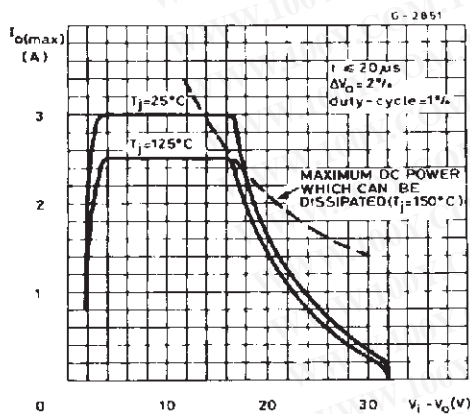

**Figure 4. Quiescent Current vs. Supply Voltage.**

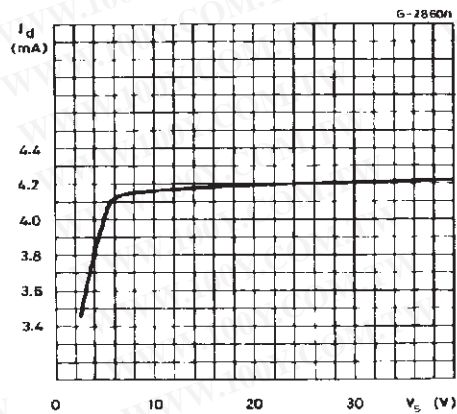



Figure 5. Quiescent Current vs. Junction Voltage.

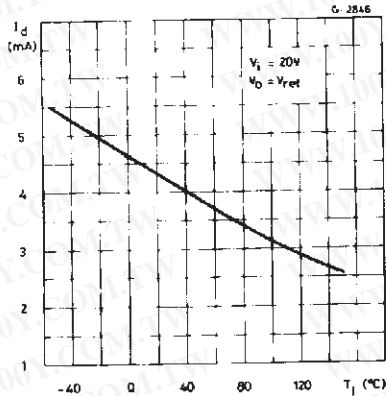

Figure 6. Quiescent Current vs. Output Current.

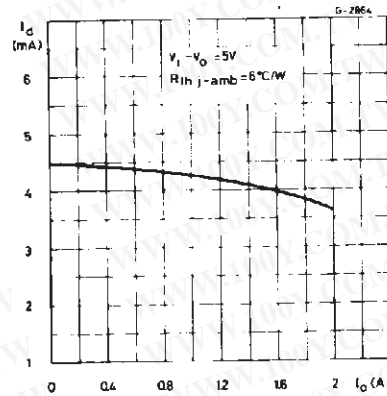

Figure 7. Output Noise Voltage vs. Output Voltage.

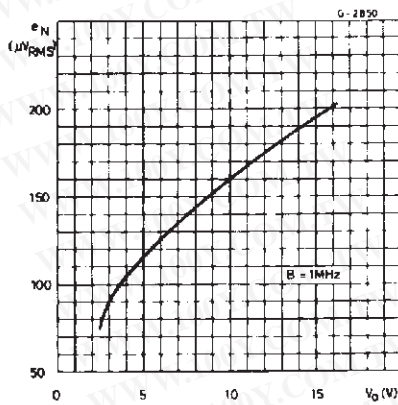

Figure 8. Output Noise Voltage vs. Frequency.

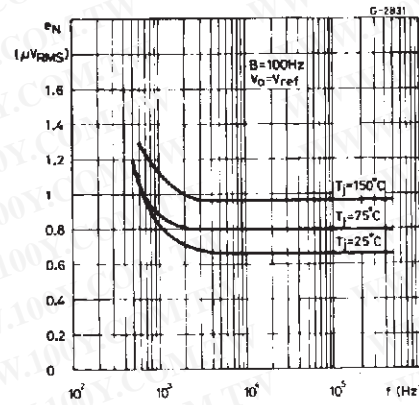

Figure 9. Reference Voltage vs. Junction Temperature.

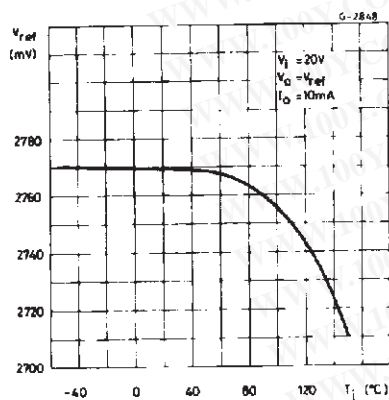
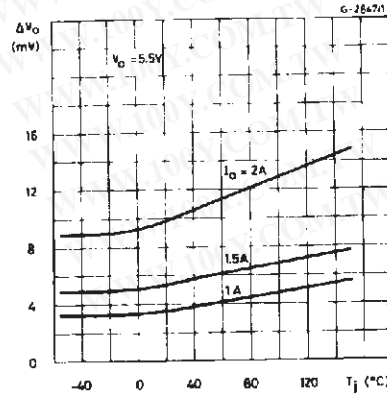

Figure 10. Voltage Load Regulation vs. Junction Temperature.



L200

Figure 11. Supply Voltage Rejection vs. Frequency.

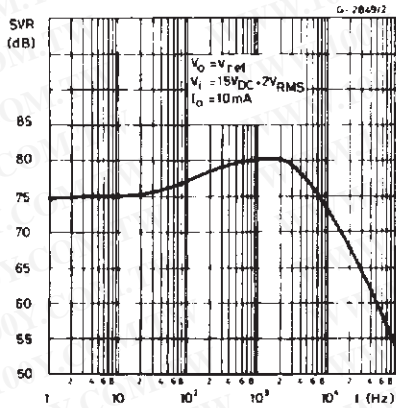

Figure 12. Dropout Voltage vs. Junction Temperature.

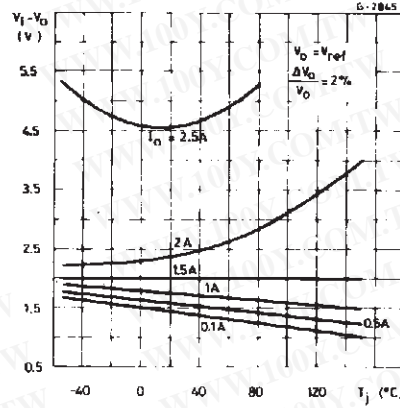

Figure 13. Output Impedance vs. Frequency.

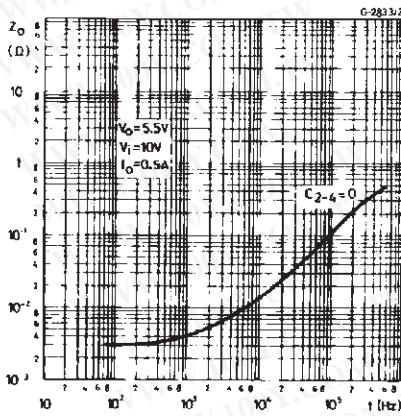

Figure 14. Output Impedance vs. Output Current.

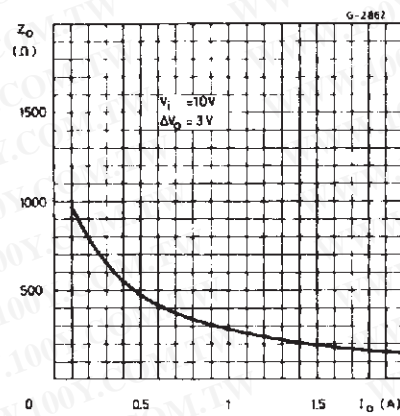

Figure 15. Voltage Transient Reponse.

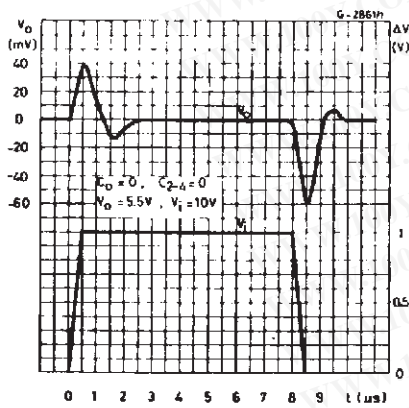

Figure 16. Load Transient Reponse.

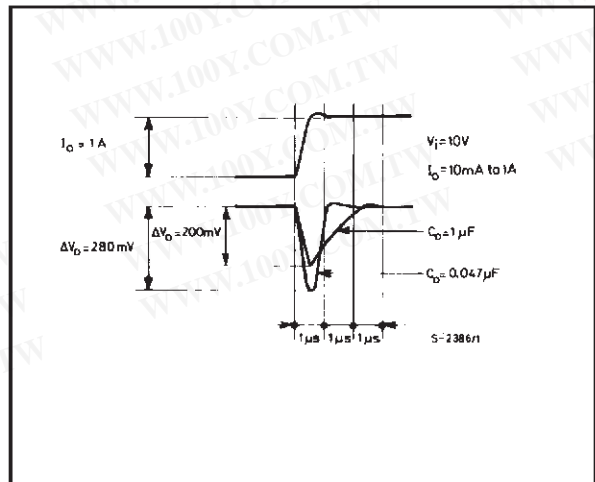

Figure 17. Load Transient Reponse

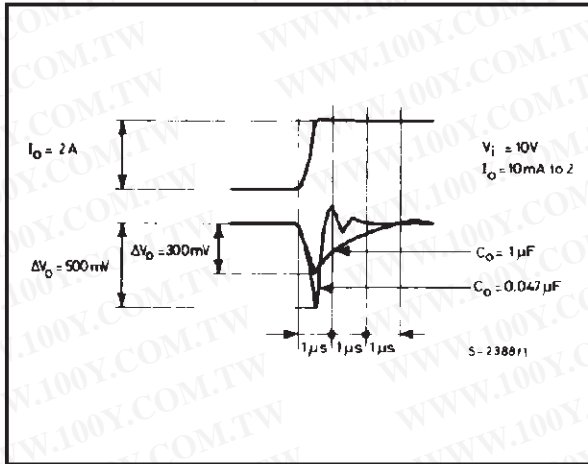
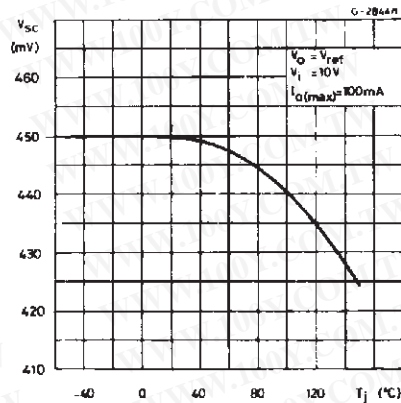

Figure 18. Current Limit Sense Voltage vs. Junction Temperature.



APPLICATIONS CIRCUITS

Figure 19. - Programmable Voltage Regulator

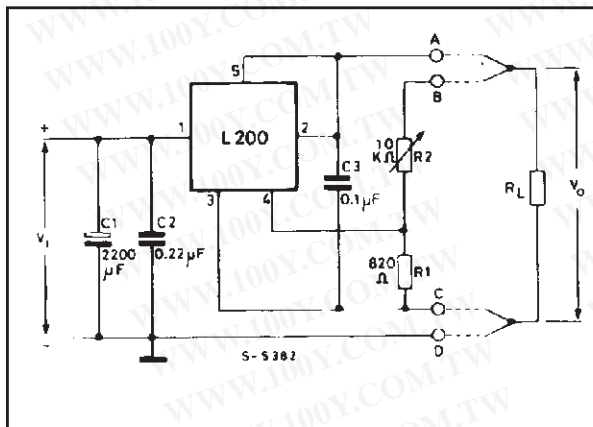

Figure 20. - P.C.Board and Components Layout of Figure 19.

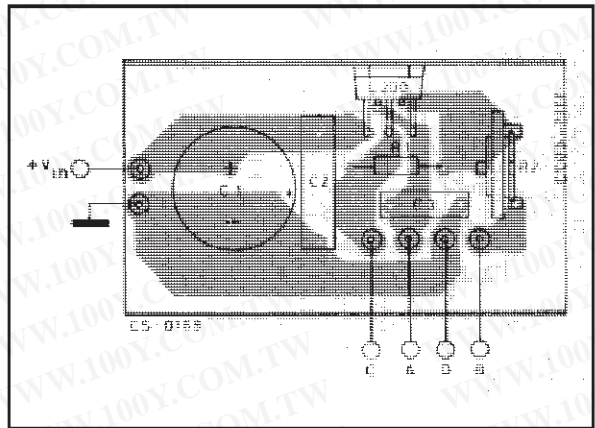

Figure 21. - High Current Voltage Regulator with Short Circuit Protection.

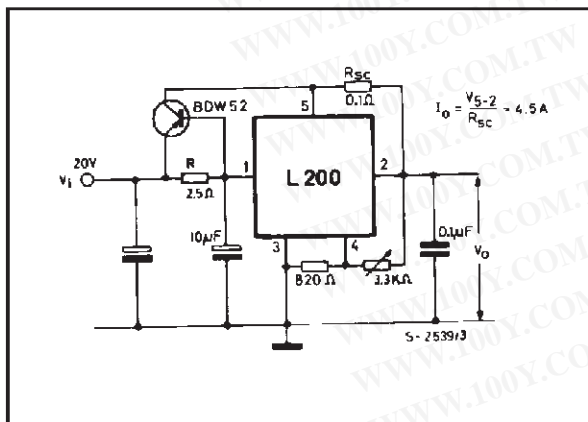
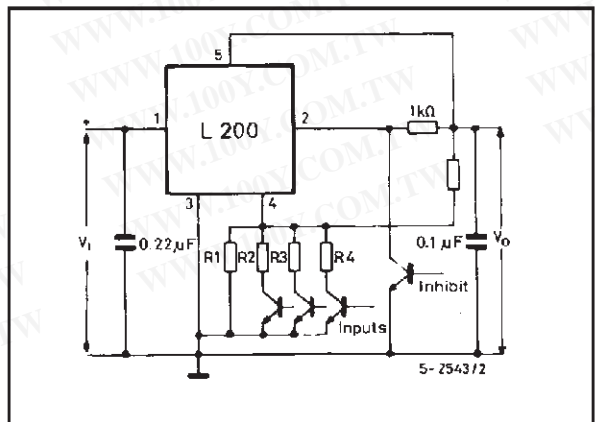
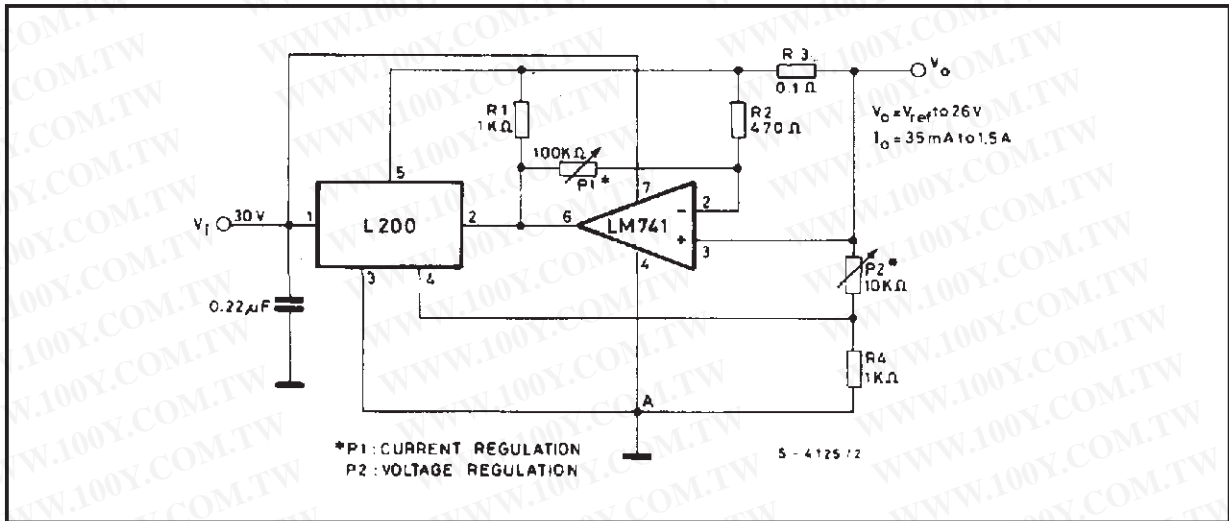

Figure 22. - Digitally Selected Regulator with Inhibit.



L200

Figure 23. Programmable Voltage and Current Regulator.



Note: Connecting point A to a negative voltage (for example -3V/10 mA) it is possible to extend the output voltage range down to 0 V and obtain the current limiting down to this level (output short-circuit condition).

Figure 24. High Current Regulator with NPN Pass Transistor.

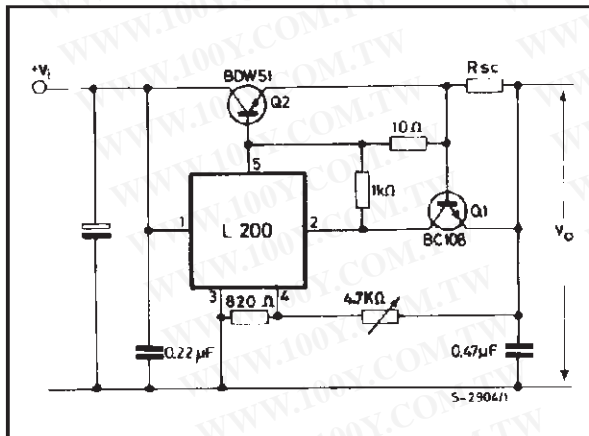

Figure 25. High Current Tracking Regulator.

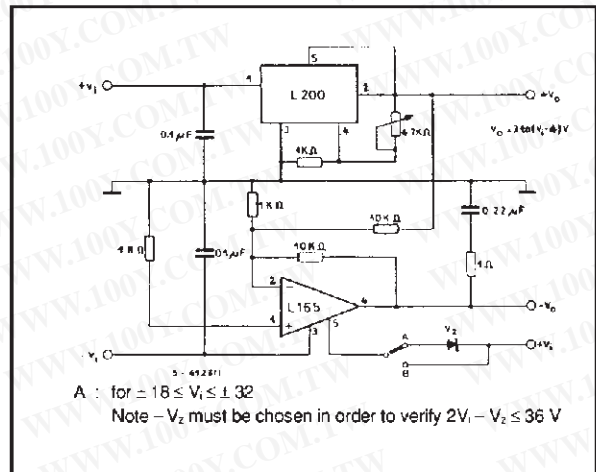



Figure 26. High Input and Output Voltage.

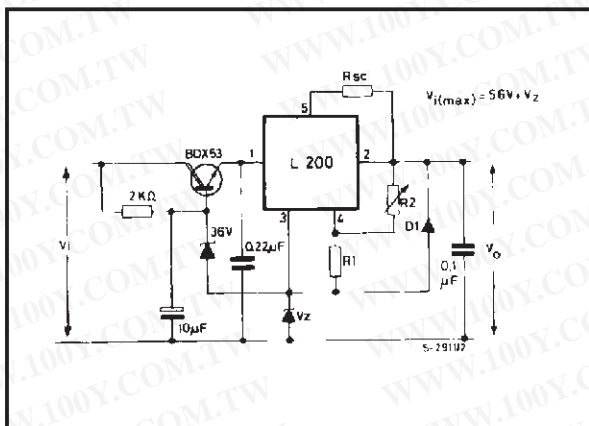
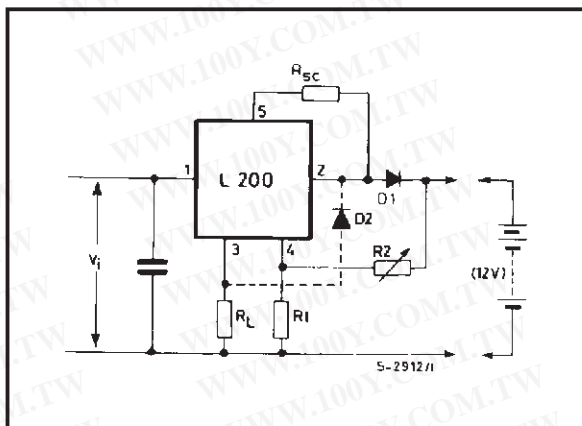

Figure 27. Constant Current Battery Charger.



The resistors  $R_1$  and  $R_2$  determine the final charging voltage and  $R_{SC}$  the initial charging current.  $D_1$  prevents discharge of the battery through the regulator.

The resistor  $R_L$  limits the reverse currents through the regulator (which should be 100 mA max) when the battery is accidentally reverse connected. If  $R_L$  is in series with a bulb of 12 V/50 mA rating this will indicate incorrect connection.

Figure 28. 30 W Motor Speed Control.

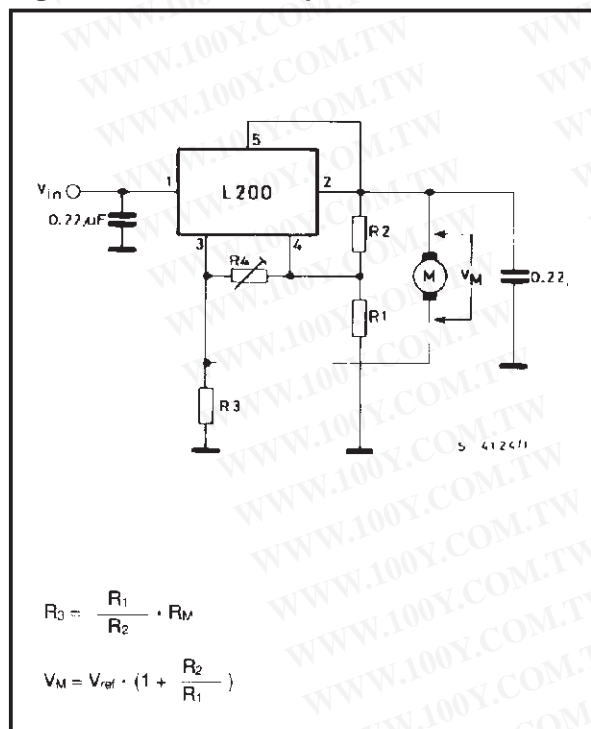

Figure 29. Lowv Turn on.

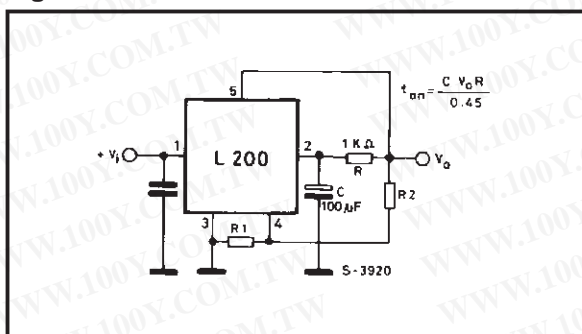
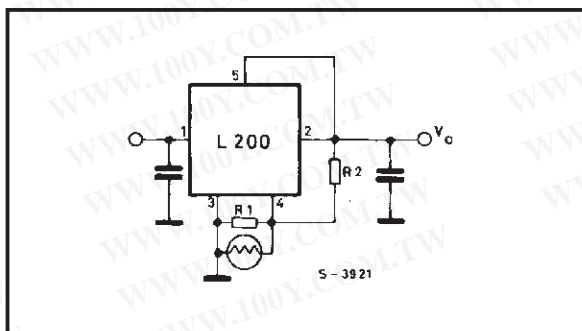

Figure 30. Light Controller.



L200

DIM.	mm			inch		
	MIN.	TYP.	MAX.	MIN.	TYP.	MAX.
A			4.8			0.189
C			1.37			0.054
D	2.4		2.8	0.094		0.110
D1	1.2		1.35	0.047		0.053
E	0.35		0.55	0.014		0.022
E1	0.76		1.19	0.030		0.047
F	0.8		1.05	0.031		0.041
F1	1		1.4	0.039		0.055
G	3.2	3.4	3.6	0.126	0.134	0.142
G1	6.6	6.8	7	0.260	0.268	0.276
H2			10.4			0.409
H3	10.05		10.4	0.396		0.409
L	17.55	17.85	18.15	0.691	0.703	0.715
L1	15.55	15.75	15.95	0.612	0.620	0.628
L2	21.2	21.4	21.6	0.831	0.843	0.850
L3	22.3	22.5	22.7	0.878	0.886	0.894
L4			1.29			0.051
L5	2.6		3	0.102		0.118
L6	15.1		15.8	0.594		0.622
L7	6		6.6	0.236		0.260
L9		0.2			0.008	
M	4.23	4.5	4.75	0.167	0.177	0.187
M1	3.75	4	4.25	0.148	0.157	0.167
V4	40° (typ.)					

OUTLINE AND MECHANICAL DATA

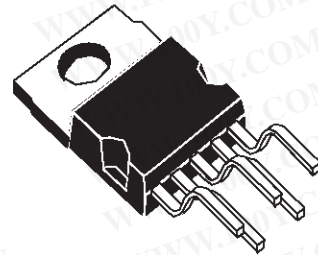

Pentawatt V

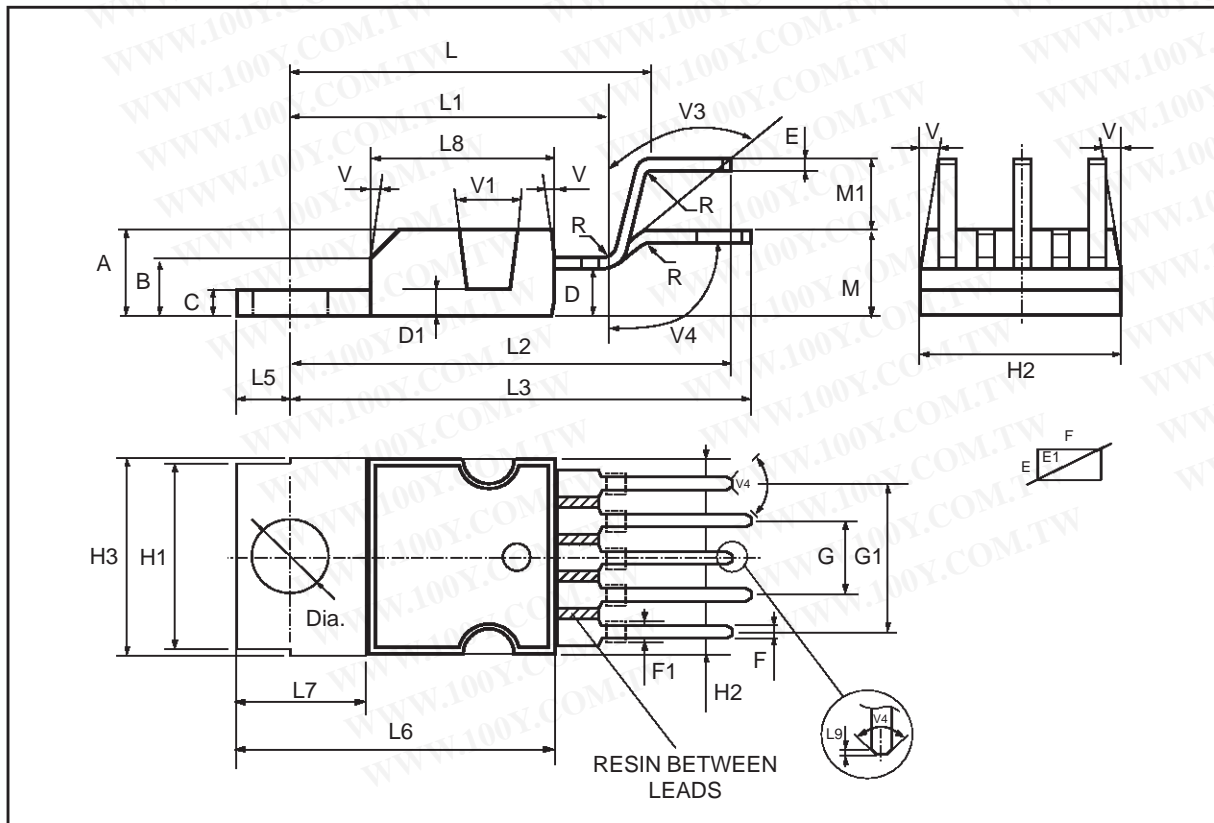

DIM.	mm			inch		
	MIN.	TYP.	MAX.	MIN.	TYP.	MAX.
A		11.8			0.46	
B (*)		1		0.39		
C			2.5			0.098
D			9.6			0.37
E			20			0.78
G		12.7			0.50	
N	50° (typ.)					
O	30° (typ.)					
P			26.2			1.03
R	3.88		4.20	0.15		0.16
U			39.5			1.55
V		30.1			1.18	

(\*) Measured with Gauge

### OUTLINE AND MECHANICAL DATA

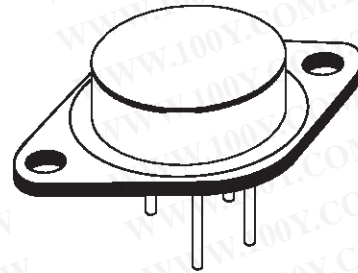

TO3 4-Leads

