



## L4902A

### DUAL 5V REGULATOR WITH RESET AND DISABLE

- DOUBLE BATTERY OPERATING
- OUTPUT CURRENTS :  $I_{O1} = 300 \text{ mA}$   
 $I_{O2} = 300 \text{ mA}$
- FIXED PRECISION OUTPUT VOLTAGE  
 $5 \text{ V} \pm 2 \%$
- RESET FUNCTION CONTROLLED BY INPUT VOLTAGE AND OUTPUT 1 VOLTAGE
- RESET FUNCTION EXTERNALLY PROGRAMMABLE TIMING
- RESET OUTPUT LEVEL RELATED TO OUTPUT 2
- OUTPUT 2 INTERNALLY SWITCHED WITH ACTIVE DISCHARGING
- OUTPUT 2 DISABLE LOGICAL INPUT
- LOW LEAKAGE CURRENT, LESS THAN  $1 \mu\text{A}$  AT OUTPUT 1
- RESET OUTPUT NORMALLY HIGH
- INPUT OVERVOLTAGE PROTECTION UP TO 60V
- OUTPUT TRANSISTORS SOA PROTECTION
- SHORT CIRCUIT AND THERMAL OVERLOAD PROTECTION

#### DESCRIPTION

The L4902A is a monolithic low drop dual 5V regulator designed mainly for supplying microprocessor systems.

Reset and data save functions and remote switch on/off control can be realized.

#### PIN CONNECTION

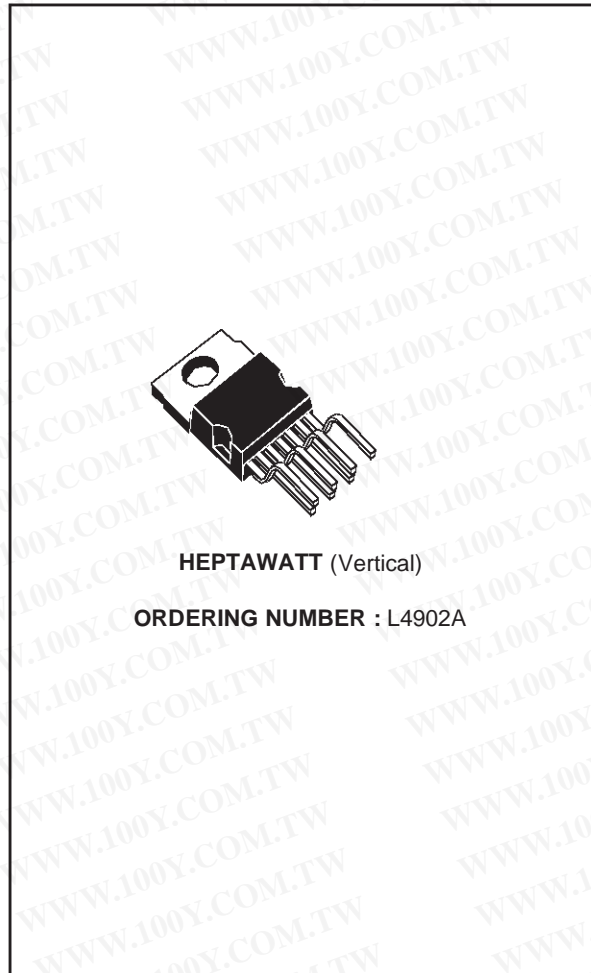
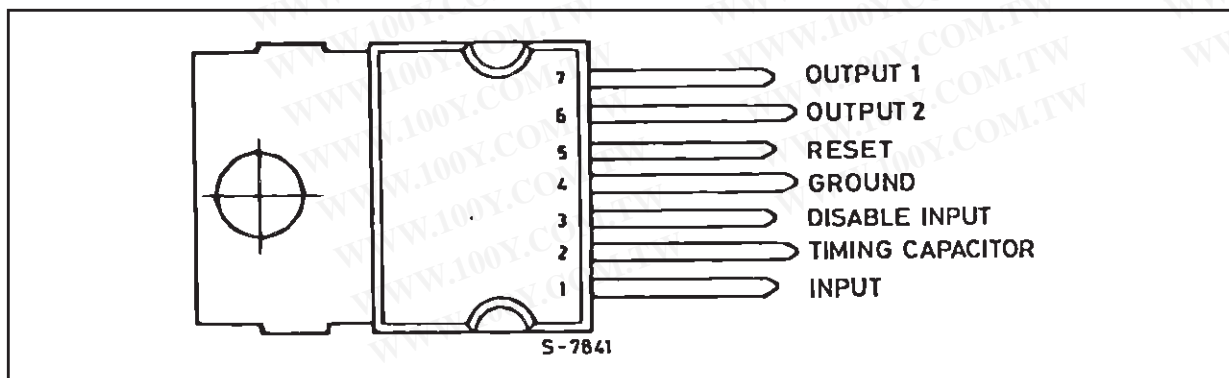

**L4902A**

**PIN FUNCTIONS**

N°	Name	Function
1	Input 1	Regulators Common Input
2	Timing Capacitor	If Reg. 2 is switched-ON the delay capacitor is charged with a 5µA constant current. When Reg. 2 is switched-OFF the delay capacitor is discharged.
3	Disable Input	A high level (> V <sub>DT</sub> ) disable output Reg. 2.
4	GND	Common Ground
5	Reset Output	When pin 2 reaches 5V the reset output is switched high. Therefore $t_{RD} = C_t \left(\frac{5V}{10\mu A}\right)$ ; $t_{RD} \text{ (ms)} = C_t \text{ (nF)}$
6	Output 2	5V – 300mA Regulator Output. Enabled if V <sub>o1</sub> > V <sub>RT</sub> . DISABLE INPUT < V <sub>DT</sub> and V <sub>IN</sub> > V <sub>IT</sub> . If Reg. 2 is switched-OFF the C <sub>02</sub> capacitor is discharged.
7	Output 1	5V – 300mA. Low leakage (in switch-OFF condition) output

**BLOCK DIAGRAM**

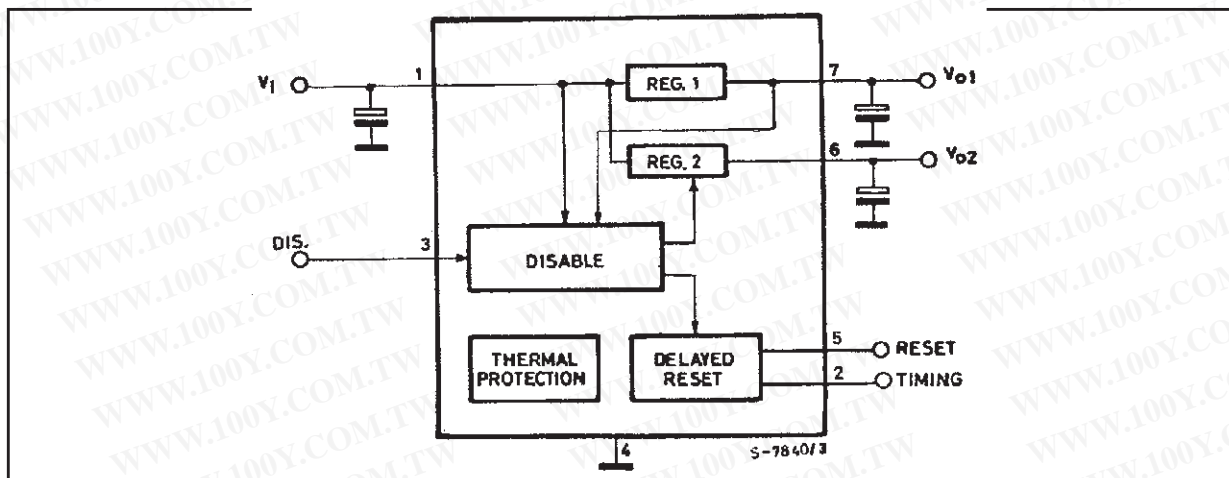

**SCHEMATIC DIAGRAM**

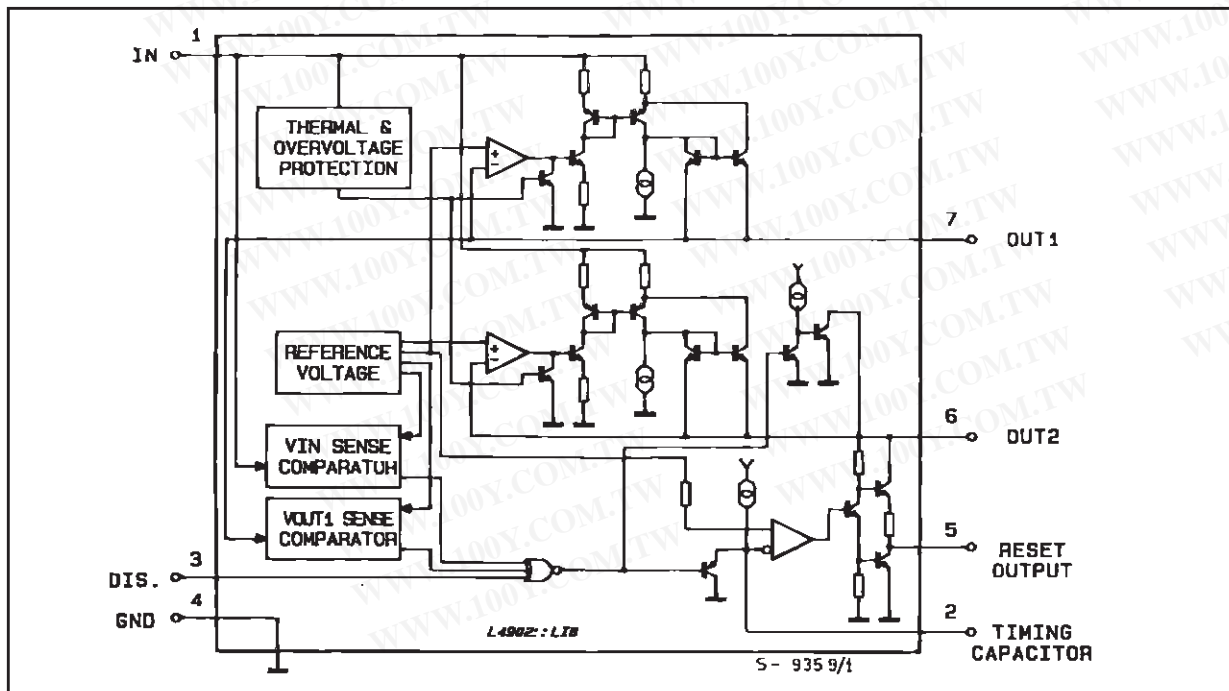

### ABSOLUTE MAXIMUM RATINGS

Symbol	Parameter	Value	Unit
$V_{IN}$	DC Input Voltage	28	V
	Transient Input Overvoltage (t = 40ms)	60	V
$I_o$	Output Current	Internally Limited	
$T_{stg}, T_j$	Storage and Junction Temperature	- 40 to 150	°C

### THERMAL DATA

Symbol	Parameter	Value	Unit
$R_{thj-case}$	Thermal Resistance Junction-case	Max 4	°C/W

### ELECTRICAL CHARACTERISTICS ( $V_{IN} = 14.4V, T_{amb} = 25^{\circ}C$ unless otherwise specified)

Symbol	Parameter	Test Conditions	Min.	Typ.	Max.	Unit
$V_i$	DC Operating Input Voltage				24	V
$V_{O1}$	Output Voltage 1	R Load 1k $\Omega$	4.95	5.05	5.15	V
$V_{O2H}$	Output Voltage 2 HIGH	R Load 1k $\Omega$	$V_{O1} - 0.1$	5	$V_{O1}$	V
$V_{O2L}$	Output Voltage 2 LOW	$I_{O2} = -5mA$		0.1		V
$I_{O1}$	Output Current 1 max.	$\Delta V_{O1} = -100mV$	300			mA
$I_{L01}$	Leakage Output 1 Current	$V_{IN} = 0, V_{O1} \leq 3V$			1	$\mu A$
$I_{O2}$	Output Current 2 max.	$\Delta V_{O2} = -100mV$	300			mA
$V_{IO1}$	Output 1 Dropout Voltage (*)	$I_{O1} = 10mA$		0.7	0.8	V
		$I_{O1} = 100mA$		0.8	1	V
		$I_{O1} = 300mA$		1.1	1.4	V
$V_{IT}$	Input Threshold Voltage		$V_{O1} + 1.2$	6.4	$V_{O1} + 1.7$	V
$V_{ITH}$	Input Threshold Voltage Hyst.			250		mV
$\Delta V_{O1}$	Line Regulation 1	$7V < V_{IN} < 24V, I_{O1} = 5mA$		5	50	mV
$\Delta V_{O2}$	Line Regulation 2	$7V < V_{IN} < 24V, I_{O2} = 5mA$		5	50	mV
$\Delta V_{O1}$	Load Regulation 1	$5mA < I_{O1} < 300mA$		40	80	mV
$\Delta V_{O2}$	Load Regulation 2	$5mA < I_{O2} < 300mA$		50	80	mV
$I_Q$	Quiescent Current	$I_{O1} = I_{O2} \leq 5mA$		4.5	6.5	mA
		$0 < V_{IN} < 13V$		2.7	4.5	
		$7V < V_{IN} < 13V, V_{O2} \text{ LOW}$		1.6	3.5	
		$7V < V_{IN} < 13V, V_{O2} \text{ HIGH}$				
$V_{RT}$	Reset Threshold Voltage		$V_{O2} - 0.15$	4.9	$V_{O2} - 0.05$	V
$V_{RTH}$	Reset Threshold Hysteresis		30	50	80	mV
$V_{RH}$	Reset Output Voltage HIGH	$I_R = 500\mu A$	$V_{O2} - 1$	4.12	$V_{O2}$	V
$V_{RL}$	Reset Output Voltage LOW	$I_R = -1mA$		0.25	0.4	V
$t_{RD}$	Reset Pulse Delay	$C_t = 10nF$	3	5	11	ms
$t_d$	Timing Capacitor Discharge Time	$C_t = 10nF$			20	$\mu s$
$V_{DT}$	$V_{O2}$ Disable Threshold Voltage			1.25	2.4	V
$I_D$	$V_{O2}$ Disable Input Current	$V_D \leq 0.4V$		- 150		$\mu A$
		$V_D \geq 2.4V$		- 30		$\mu A$
$\frac{\Delta V_{O1}}{\Delta T}$	Thermal Drift	$-20^{\circ}C \leq T_{amb} \leq 125^{\circ}C$		0.3		mV/°C
				- 0.8		
$\frac{\Delta V_{O2}}{\Delta T}$	Thermal Drift	$-20^{\circ}C \leq T_{amb} \leq 125^{\circ}C$		0.3		mV/°C
				- 0.8		
SVR1	Supply Voltage Rejection	f = 100Hz $V_R = 0.5V$ $I_o = 100mA$	50	84		dB
SVR2	Supply Voltage Rejection		50	80		dB

\* The dropout voltage is defined as the difference between the input and the output voltage when the output voltage is lowered of 25 mV under constant output current condition.

L4902A

TEST CIRCUIT

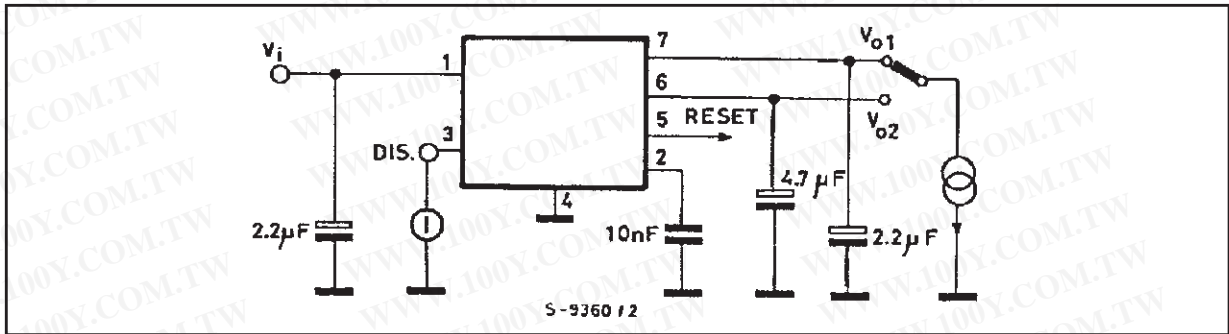

APPLICATION INFORMATION

In power supplies for  $\mu$ P systems it is necessary to provide power continuously to avoid loss of information in memories and in time of day clocks, or to save data when the primary supply is removed. The L4902A makes it very easy to supply such equipments ; it provides two voltage regulators (both 5V high precision) with common inputs plus a reset output for the data save function and a Reg. 2 disable input.

CIRCUIT OPERATION (see Figure 1)

After switch on Reg. 1 saturates until  $V_{O1}$  rises to the nominal value.

When the input reaches  $V_{IT}$  and the output 1 is higher than  $V_{RT}$  the output 2 ( $V_{O2}$ ) switches on and the reset output ( $V_R$ ) also goes high after a pro-

grammable time  $T_{RD}$  (timing capacitor).

$V_{O2}$  and  $V_R$  are switched together at low level when one of the following conditions occurs :

- a high level ( $V_{DT}$ ) is applied on pin 3 ;
- an input overvoltage ;
- an overload on the output 1 ( $V_{O1} > V_{RT}$ ) ;
- a switch off ( $V_{IN} < V_{IT} - V_{ITH}$ ) ;

and they start again as before when the condition is removed.

An overload on output 2 does not switch Reg. 2, and does not influence Reg. 1.

The  $V_{O1}$  output features :

- 5V internal reference without voltage divider between the output and the error comparator
- very low drop series regulator element utilizing current mirrors

permit high output impedance and then very low leakage current even in power down condition.

Figure 1

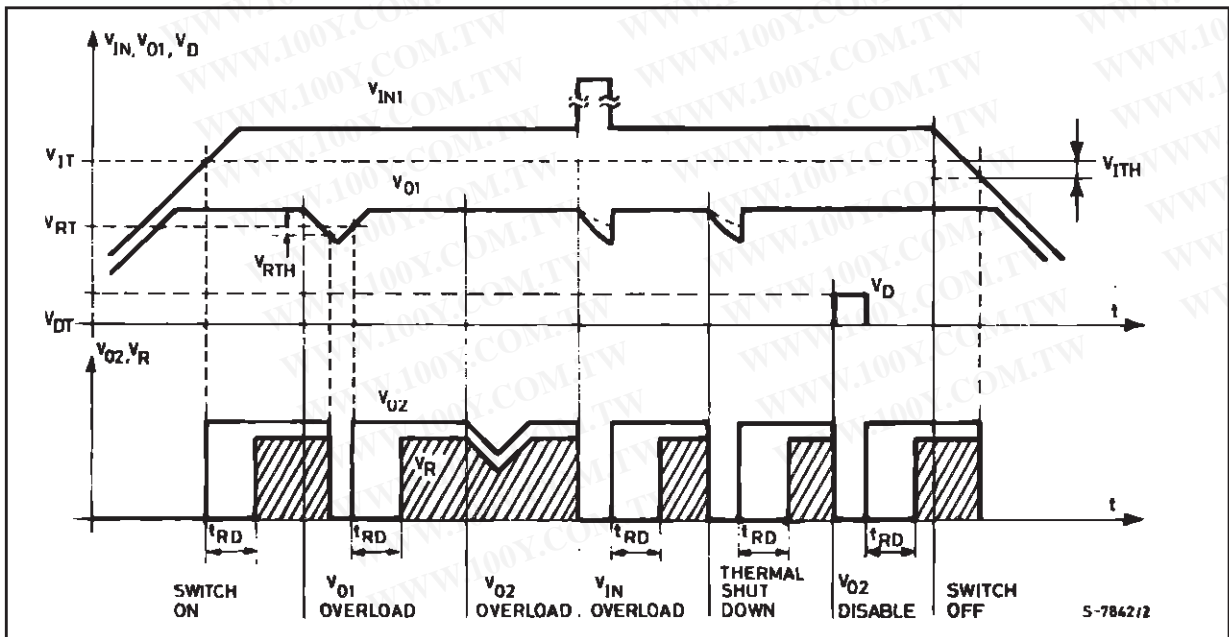

This output may therefore be used to supply circuits continuously, such as volatile RAMs, allowing the use of a back-up battery.

The  $V_{O2}$  output can supply other non essential 5 V circuits which may be powered down when the system is inactive, or that must be powered down to prevent uncorrect operation for supply voltages below the minimum value.

The reset output can be used as a "POWER DOWN INTERRUPT", permitting RAM access only in correct power conditions, or as a "BACK-UP ENABLE" to transfer data into in a NV SHADOW MEMORY

when the supply is interrupted.

The disable function can be used for remote on/off control of circuits connected to the  $V_{O2}$  output.

### APPLICATION SUGGESTIONS

Figure 2 illustrate how the L4902A's disable input may be used in a CMOS  $\mu$ Computer application. The  $V_{O1}$  regulator (low consumption) supply permanently a CMOS time of day clock and a CMOS  $\mu$ computer chip with volatile memory.  $V_{O2}$  output, supplying non-essential circuits, is turned OFF under control of a  $\mu$ P unit.

Figure 2

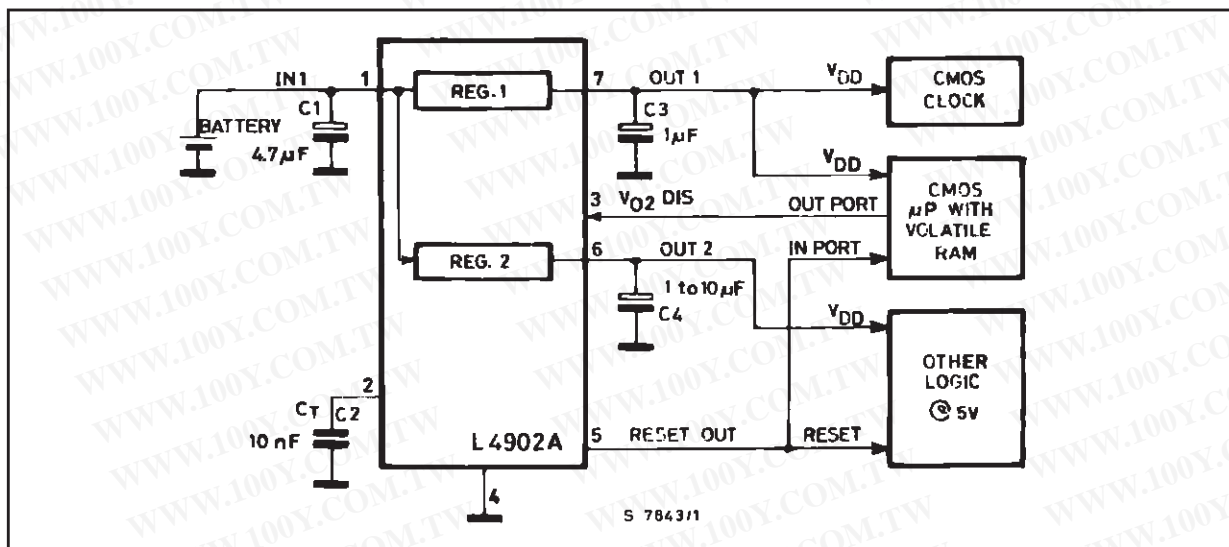
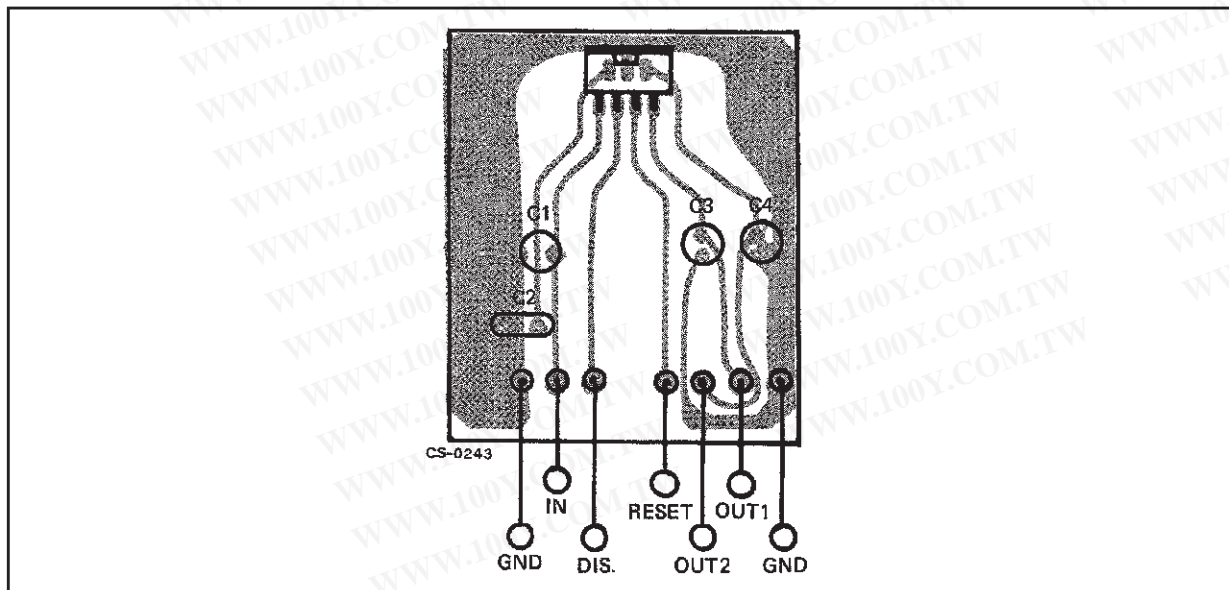

Figure 3 : P.C. Board Component Layout of Figure 2



## L4902A

Configurations of this type are used in products where the OFF switch is part of a keyboard scanned by a micro which operates continuously even in the OFF state.

Another application for the L4902A is supplying a shadow-ram microcomputer chip (SGS M38SH72 for example) where a fast NV memory is backed up on chip by a EEPROM when a low level on the reset output occurs.

By adding two CMOS-SCHMIDT-TRIGGER and few external components, also a watch dog func-

tion may be realized (see Figure 5). During normal operation the microsystem supplies a periodical pulse waveform; if an anomalous condition occurs (in the program or in the system), the pulses will be absent and the disable input will be activated after a settling time determined by R1 C1. In this condition all the circuitry connected to V<sub>O2</sub> will be disabled, the system will be restarted with a new reset front.

The disable of V<sub>O2</sub> prevent spurious operation during microprocessor malfunctioning.

Figure 4

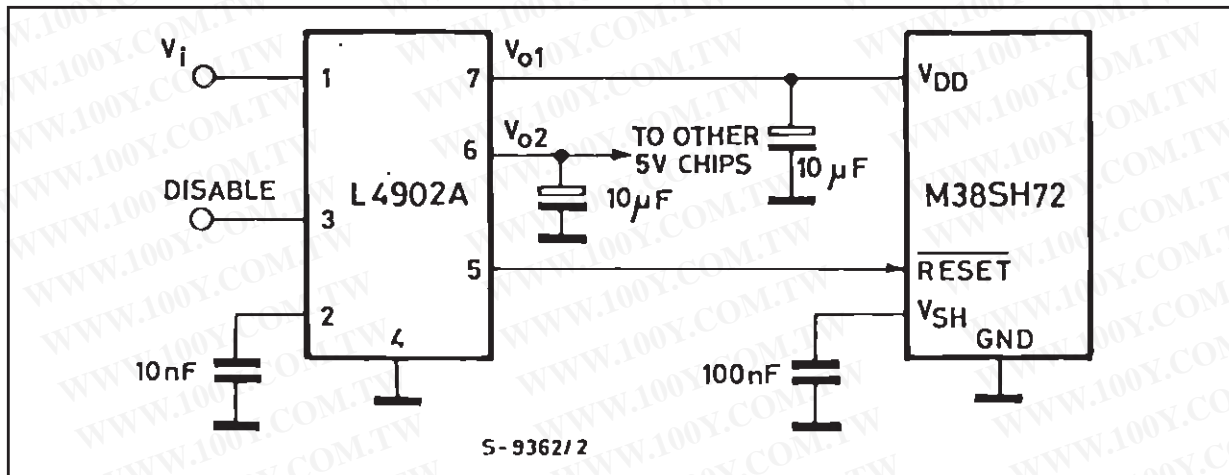

Figure 5

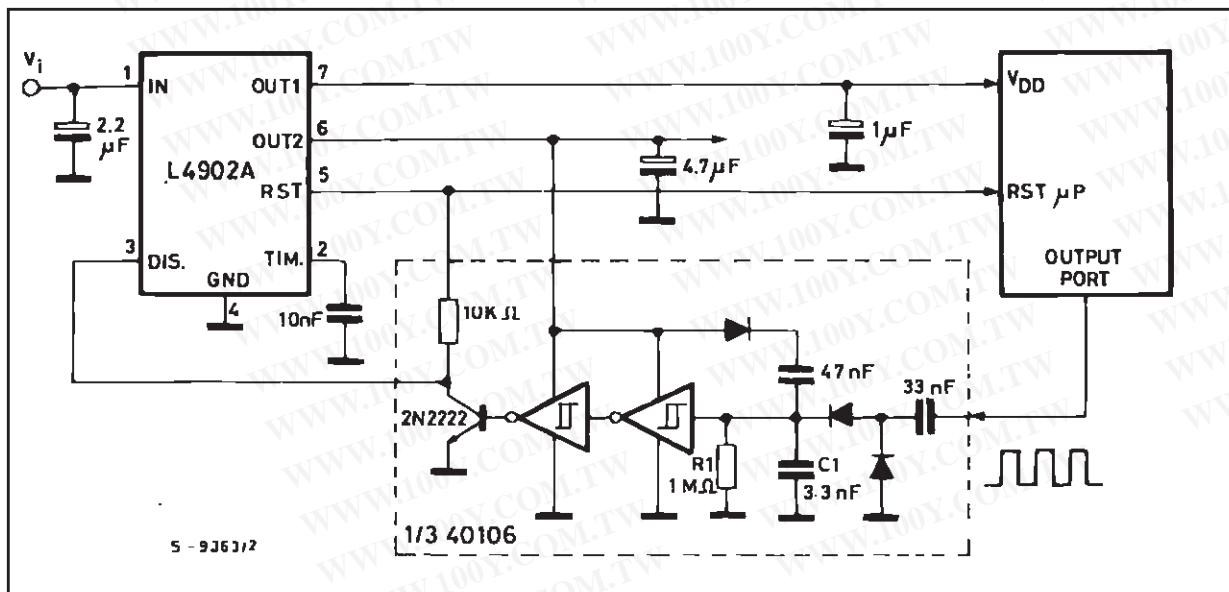

Figure 6 : Quiescent Current versus Output Current

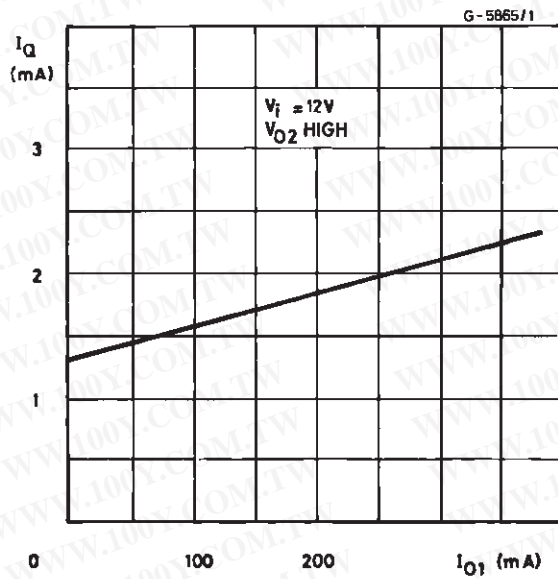

Figure 7 : Quiescent Current versus Input Voltage

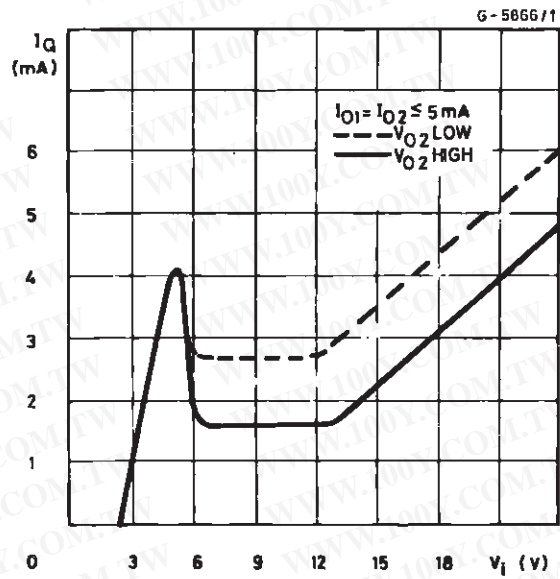
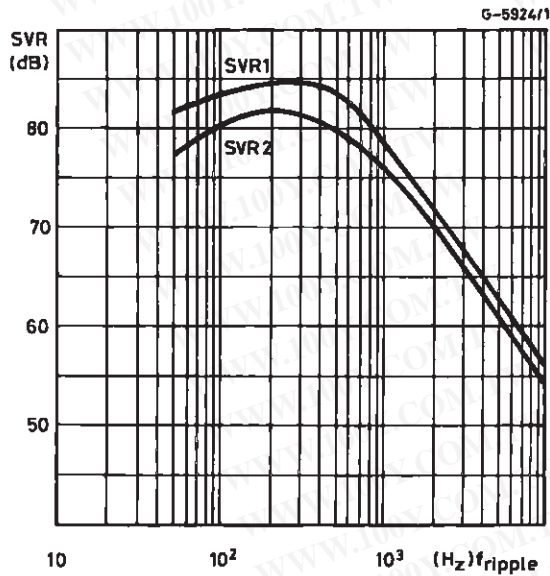

Figure 8 : Supply Voltage Rejection Regulators 1 and 2 versus Input Ripple Frequency



**L4902A**

DIM.	mm			inch		
	MIN.	TYP.	MAX.	MIN.	TYP.	MAX.
A			4.8			0.189
C			1.37			0.054
D	2.4		2.8	0.094		0.110
D1	1.2		1.35	0.047		0.053
E	0.35		0.55	0.014		0.022
E1	0.7		0.97	0.028		0.038
F	0.6		0.8	0.024		0.031
F1			0.9			0.035
G	2.34	2.54	2.74	0.095	0.100	0.105
G1	4.88	5.08	5.28	0.193	0.200	0.205
G2	7.42	7.62	7.82	0.295	0.300	0.307
H2			10.4			0.409
H3	10.05		10.4	0.396		0.409
L	16.7	16.9	17.1	0.657	0.668	0.673
L1		14.92			0.587	
L2	21.24	21.54	21.84	0.386	0.848	0.860
L3	22.27	22.52	22.77	0.877	0.891	0.896
L4			1.29			0.051
L5	2.6	2.8	3	0.102	0.110	0.118
L6	15.1	15.5	15.8	0.594	0.610	0.622
L7	6	6.35	6.6	0.236	0.250	0.260
L9		0.2			0.008	
M	2.55	2.8	3.05	0.100	0.110	0.120
M1	4.83	5.08	5.33	0.190	0.200	0.210
V4	40° (typ.)					
Dia	3.65		3.85	0.144		0.152

**OUTLINE AND MECHANICAL DATA**

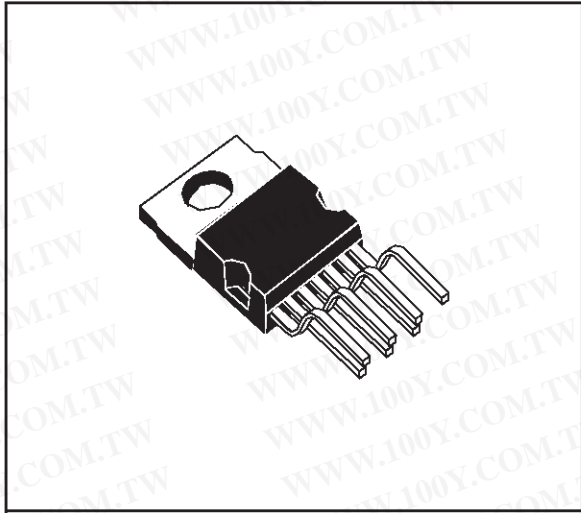

**Heptawatt V**

