

## Current Transducer LTC 1000-S

$I_{PN} = 1000 \text{ A}$

For the electronic measurement of currents : DC, AC, pulsed..., with a galvanic isolation between the primary circuit (high power) and the secondary circuit (electronic circuit).

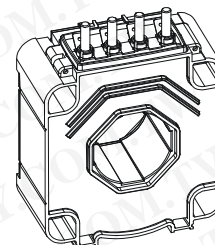

### Electrical data

$I_{PN}$	Primary nominal r.m.s. current	1000	A			
$I_P$	Primary current, measuring range @ $\pm 24 \text{ V}$	$0 \dots \pm 2400$ <sup>1)</sup>	A			
$\hat{I}_P$	Max overload not measurable	10 / 10	kA/ms			
$R_M$	Measuring resistance	$R_{Mmin}$	$R_{Mmax}$			
				with $\pm 15 \text{ V}$	@ $\pm 1000 \text{ A}_{max}$	0
		with $\pm 24 \text{ V}$	@ $\pm 1200 \text{ A}_{max}$	0	7	$\Omega$
		with $\pm 24 \text{ V}$	@ $\pm 1000 \text{ A}_{max}$	0	50	$\Omega$
with $\pm 24 \text{ V}$	@ $\pm 2000 \text{ A}_{max}$	0	7	$\Omega$		
$I_{SN}$	Secondary nominal r.m.s. current	200	mA			
$K_N$	Conversion ratio	1 : 5000				
$V_C$	Supply voltage ( $\pm 5 \%$ )	$\pm 15 \dots 24$	V			
$I_C$	Current consumption	$< 30 (@ \pm 24 \text{ V}) + I_S$	mA			

### Features

- Closed loop (compensated) current transducer using the Hall effect
- Insulated plastic case recognized according to UL 94-V0
- Railway equipment.

### Advantages

- Excellent accuracy
- Very good linearity
- Low temperature drift
- Optimized response time
- Wide frequency bandwidth
- No insertion losses
- High immunity to external interference
- Current overload capability.

### Accuracy - Dynamic performance data

$X_G$	Overall accuracy @ $I_{PN}, T_A = 25^\circ\text{C}$	$< \pm 0.4$	%
		@ $I_{PN}, T_A = -40^\circ\text{C} \dots +85^\circ\text{C}$	$< \pm 1$
$e_L$	Linearity error	$< 0.1$	%
$I_O$	Offset current @ $I_P = 0, T_A = 25^\circ\text{C}$	Max $\pm 0.5$	mA
$I_{OT}$	Thermal drift of $I_O$	$-40^\circ\text{C} \dots +85^\circ\text{C}$	$\pm 1$ mA
$t_r$	Response time <sup>2)</sup> @ 90 % of $I_{PN}$	$< 1$	$\mu\text{s}$
$di/dt$	di/dt accurately followed	$> 100$	A/ $\mu\text{s}$
$f$	Frequency bandwidth (-1 dB)	DC .. 100	kHz

### Applications

- AC variable speed drives and servo motor drives
- Static converters for DC motor drives
- Battery supplied applications
- Uninterruptible Power Supplies (UPS)
- Switched Mode Power Supplies (SMPS)
- Power supplies for welding applications.

### General data

$T_A$	Ambient operating temperature	$-40 \dots +85$	$^\circ\text{C}$
$T_S$	Ambient storage temperature	$-45 \dots +90$	$^\circ\text{C}$
$R_S$	Secondary coil resistance @ $T_A = 85^\circ\text{C}$	44	$\Omega$
$m$	Mass	750	g
	Standards	EN 50155 : 2001	

### Application Domain

- Traction

Notes : <sup>1)</sup> With a di/dt of  $> 5 \text{ A}/\mu\text{s}$   
<sup>2)</sup> With a di/dt of  $100 \text{ A}/\mu\text{s}$ .

## Current Transducer LTC 1000-S

### Isolation characteristics

$V_d$	R.m.s. voltage for AC isolation test, 50 Hz, 1 mn	13.4 <sup>3)</sup> 1.5 <sup>4)</sup>	kV kV
$V_e$	R.m.s. voltage for partial discharge extinction	> 2.8 <sup>5)</sup>	kV
		Min	
dCp	Creepage distance	66.70	mm
dCl	Clearance distance	45.90	mm
CTI	Comparative Tracking Index (Group I)	600	

Notes : <sup>3)</sup> Between primary and secondary + shield  
<sup>4)</sup> Between secondary and shield  
<sup>5)</sup> Test carried out with a busbar  $\varnothing$  40 mm centred in the through-hole.

### Safety



This transducer must be used in electric/electronic equipment with respect to applicable standards and safety requirements in accordance with the following manufacturer's operating instructions.



Caution, risk of electrical shock

When operating the transducer, certain parts of the module can carry hazardous voltage (eg. primary busbar, power supply).

Ignoring this warning can lead to injury and/or cause serious damage.

This transducer is a built-in device, whose conducting parts must be inaccessible after installation.

A protective housing or additional shield could be used.

Main supply must be able to be disconnected.

**Dimensions LTC 1000-S** (in mm. 1 mm = 0.0394 inch)

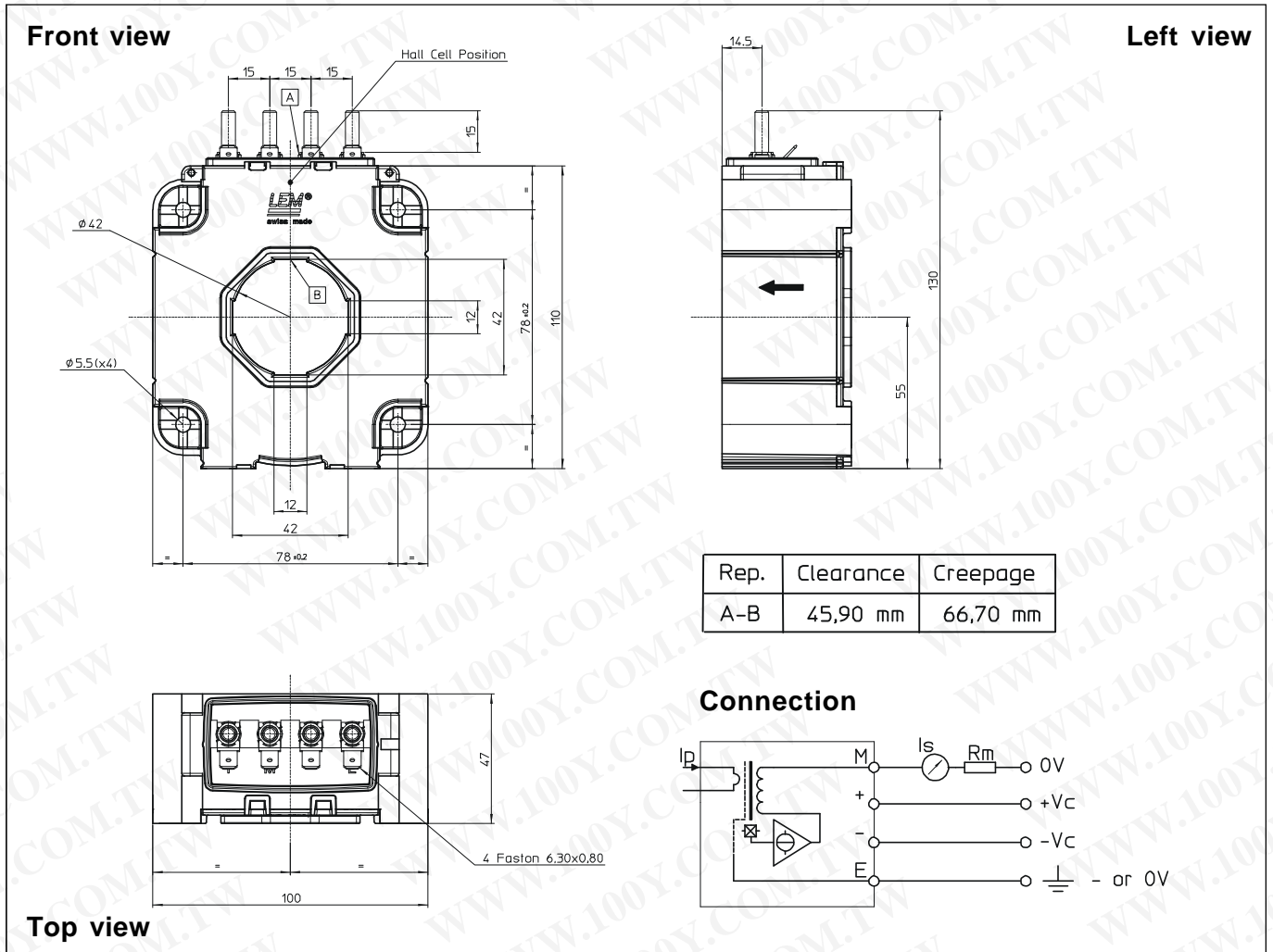

**Mechanical characteristics**

- General tolerance  $\pm 1$  mm
- Fixing the transducer 4 holes  $\varnothing 5.5$  mm  
4 screws M5
- Recommended fastening torque 4 Nm or 2.95 Lb.-Ft.
- Primary through-hole  $\varnothing 42$  mm
- Connection of secondary M5 threaded studs  
Recommended fastening torque 2.2 Nm or 1.62 Lb.-Ft.  
Faston 6.3 x 0.8 mm

**Remarks**

- $I_s$  is positive when  $I_p$  flows in the direction of the arrow.
- Temperature of the primary conductor should not exceed  $100^\circ\text{C}$ .
- Dynamic performances (di/dt and response time) are best with a single bar completely filling the primary hole.
- This is a standard model. For different versions (supply voltages, turns ratios, unidirectional measurements...), please contact us.

**LTC 1000-S / Mechanical adaptation accessories**

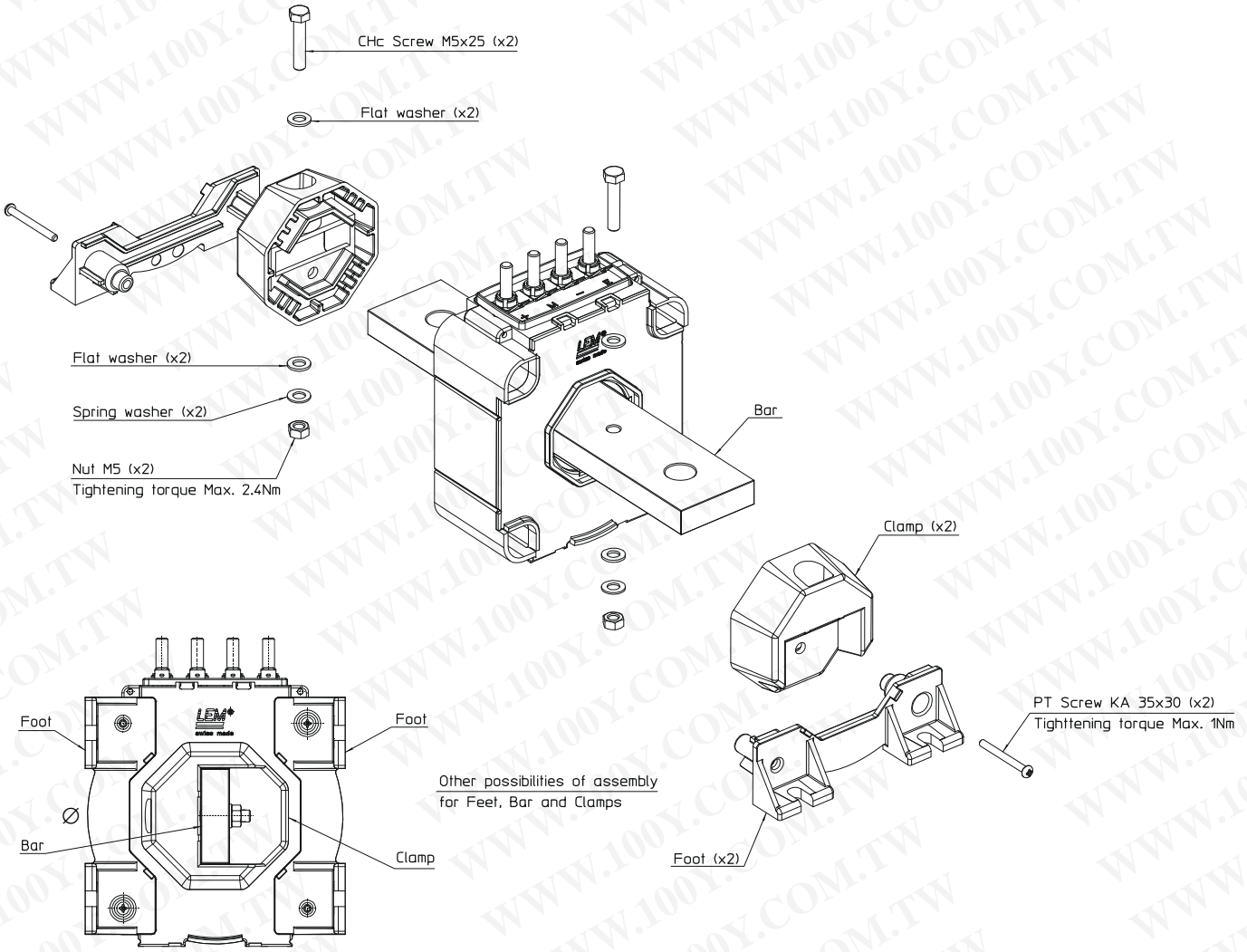

Lines	Accessories	References
1	Busbar KIT * (busbar : 210 x 40 x 12 mm)	93.34.61.100.0
2	Busbar KIT * (busbar : 185 x 40 x 8 mm)	93.34.61.102.0
3	Busbar KIT * (busbar : 285 x 36 x 12 mm)	93.34.61.103.0
4	Busbar KIT * (busbar : 260 x 36 x 12 mm)	93.34.61.104.0
5	Busbar KIT * (busbar : 195 x 36 x 10 mm)	93.34.61.105.0
6	Busbar KIT * (busbar : 36 mm $\varnothing$ x 325 mm)	93.34.61.106.0
7	Busbar KIT * (busbar : 185 x 40 x 10 mm)	93.34.61.107.0
8	Busbar KIT * (busbar : 180 x 40 x 12 mm)	93.34.61.108.0
9	Busbar Fastening Kit (M5 x 25) **dedicated to busbars from lines 1 to 5 and lines 7, 8.	93.34.61.200.0
10	Busbar Fastening Kit (M5 X 40)** dedicated to busbar from line 6	93.34.61.201.0
11	Feet fixing Kit ***	93.34.63.100.0

\* including all the necessary for its mounting such as screws, washers, nuts, 2 clamps, busbar.  
 \*\* as with \* but without the busbar.  
 \*\*\* including screws and 2 feet.



R.m.s. voltage value for partial discharge extinction depends on the busbar.  
 Refer to the datasheet of the corresponding product.