

LM101A/LM201A/LM301A Operational Amplifiers

General Description

The LM101A series are general purpose operational amplifiers which feature improved performance over industry standards like the LM709. Advanced processing techniques make possible an order of magnitude reduction in input currents, and a redesign of the biasing circuitry reduces the temperature drift of input current. Improved specifications include:

- Offset voltage 3 mV maximum over temperature (LM101A/LM201A)
- Input current 100 nA maximum over temperature (LM101A/LM201A)
- Offset current 20 nA maximum over temperature (LM101A/LM201A)
- Guaranteed drift characteristics
- Offsets guaranteed over entire common mode and supply voltage ranges
- Slew rate of 10V/μs as a summing amplifier

This amplifier offers many features which make its application nearly foolproof: overload protection on the input

and output, no latch-up when the common mode range is exceeded, and freedom from oscillations and compensation with a single 30 pF capacitor. It has advantages over internally compensated amplifiers in that the frequency compensation can be tailored to the particular application. For example, in low frequency circuits it can be overcompensated for increased stability margin. Or the compensation can be optimized to give more than a factor of ten improvement in high frequency performance for most applications.

In addition, the device provides better accuracy and lower noise in high impedance circuitry. The low input currents also make it particularly well suited for long interval integrators or timers, sample and hold circuits and low frequency waveform generators. Further, replacing circuits where matched transistor pairs buffer the inputs of conventional IC op amps, it can give lower offset voltage and a drift at a lower cost.

The LM101A is guaranteed over a temperature range of -55°C to $+125^{\circ}\text{C}$, the LM201A from -25°C to $+85^{\circ}\text{C}$, and the LM301A from 0°C to $+70^{\circ}\text{C}$.

Fast AC/DC Converter (Note 1)

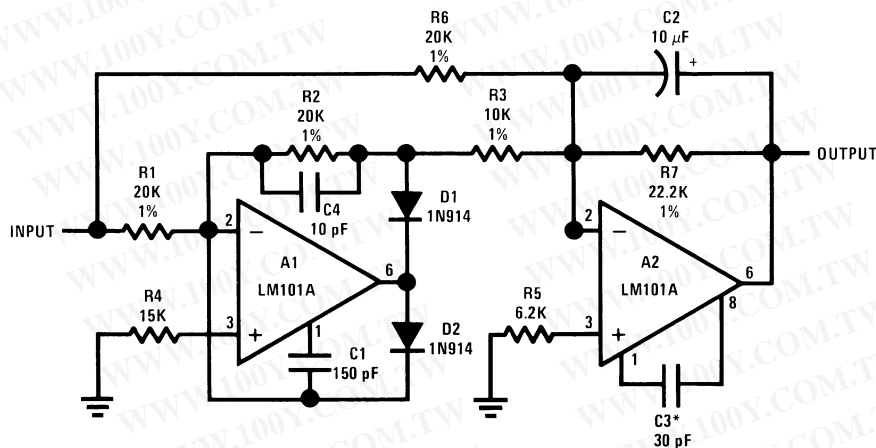

DS007752-33

Note 1: Feedforward compensation can be used to make a fast full wave rectifier without a filter.

勝特力材料 886-3-5753170
 勝特力电子(上海) 86-21-54151736
 勝特力电子(深圳) 86-755-83298787
[Http://www.100y.com.tw](http://www.100y.com.tw)

Absolute Maximum Ratings (Note 2)

If Military/Aerospace specified devices are required, please contact the National Semiconductor Sales Office/Distributors for availability and specifications.

	LM101A/LM201A	LM301A
Supply Voltage	±22V	±18V
Differential Input Voltage	±30V	±30V
Input Voltage (Note 3)	±15V	±15V
Output Short Circuit Duration (Note 4)	Continuous	Continuous
Operating Ambient Temp. Range	-55°C to +125°C (LM101A) -25°C to +85°C (LM201A)	0°C to +70°C
T _J Max		
H-Package	150°C	100°C
N-Package	150°C	100°C
J-Package	150°C	100°C
Power Dissipation at T _A = 25°C		
H-Package (Still Air)	500 mW	300 mW
(400 LF/Min Air Flow)	1200 mW	700 mW
N-Package	900 mW	500 mW
J-Package	1000 mW	650 mW
Thermal Resistance (Typical) θ _{JA}		
H-Package (Still Air)	165°C/W	165°C/W
(400 LF/Min Air Flow)	67°C/W	67°C/W
N Package	135°C/W	135°C/W
J-Package	110°C/W	110°C/W
(Typical) θ _{JC}		
H-Package	25°C/W	25°C/W
Storage Temperature Range	-65°C to +150°C	-65°C to +150°C
Lead Temperature (Soldering, 10 sec.)		
Metal Can or Ceramic	300°C	300°C
Plastic	260°C	260°C
ESD Tolerance (Note 7)	2000V	2000V

Electrical Characteristics (Note 5)

T_A = T_J

Parameter	Conditions	LM101A/LM201A			LM301A			Units
		Min	Typ	Max	Min	Typ	Max	
Input Offset Voltage	T _A = 25°C, R _S ≤ 50 kΩ		0.7	2.0		2.0	7.5	mV
Input Offset Current	T _A = 25°C		1.5	10		3.0	50	nA
Input Bias Current	T _A = 25°C		30	75		70	250	nA
Input Resistance	T _A = 25°C	1.5	4.0		0.5	2.0		MΩ
Supply Current	T _A = 25°C		V _S = ±20V	1.8	3.0			mA
			V _S = ±15V			1.8	3.0	mA
Large Signal Voltage Gain	T _A = 25°C, V _S = ±15V V _{OUT} = ±10V, R _L ≥ 2 kΩ	50	160		25	160		V/mV
Input Offset Voltage	R _S ≤ 50 kΩ			3.0			10	mV
Average Temperature Coefficient of Input Offset Voltage	R _S ≤ 50 kΩ		3.0	15		6.0	30	μV/°C
Input Offset Current				20			70	nA
Average Temperature Coefficient of Input Offset Current	25°C ≤ T _A ≤ T _{MAX} T _{MIN} ≤ T _A ≤ 25°C		0.01	0.1		0.01	0.3	nA/°C
			0.02	0.2		0.02	0.6	nA/°C
Input Bias Current				0.1			0.3	μA
Supply Current	T _A = T _{MAX} , V _S = ±20V		1.2	2.5				mA

Electrical Characteristics (Note 5) (Continued)

$$T_A = T_J$$

Parameter	Conditions	LM101A/LM201A			LM301A			Units
		Min	Typ	Max	Min	Typ	Max	
Large Signal Voltage Gain	$V_S = \pm 15V$, $V_{OUT} = \pm 10V$ $R_L \geq 2k$	25			15			V/mV
Output Voltage Swing	$V_S = \pm 15V$	$R_L = 10 k\Omega$	± 12	± 14	± 12	± 14		V
		$R_L = 2 k\Omega$	± 10	± 13	± 10	± 13		V
Input Voltage Range	$V_S = \pm 20V$	± 15						V
	$V_S = \pm 15V$		+15, -13		± 12	+15, -13		V
Common-Mode Rejection Ratio	$R_S \leq 50 k\Omega$	80	96		70	90		dB
Supply Voltage Rejection Ratio	$R_S \leq 50 k\Omega$	80	96		70	96		dB

Note 2: Absolute Maximum Ratings indicate limits beyond which damage to the device may occur. Operating ratings indicate for which the device is functional, but do not guarantee specific performance limits. Electrical Characteristics state DC and AC electrical specifications under particular test conditions which guarantee specific limits. This assumes that the device is within the Operating Ratings. Specifications are not guaranteed for parameters where no limit is given, however, the typical value is a good indication of device performance.

Note 3: For supply voltages less than $\pm 15V$, the absolute maximum input voltage is equal to the supply voltage.

Note 4: Continuous short circuit is allowed for case temperatures to $125^\circ C$ and ambient temperatures to $75^\circ C$ for LM101A/LM201A, and $70^\circ C$ and $55^\circ C$ respectively for LM301A.

Note 5: Unless otherwise specified, these specifications apply for $C_1 = 30 pF$, $\pm 5V \leq V_S \leq \pm 20V$ and $-55^\circ C \leq T_A \leq +125^\circ C$ (LM101A), $\pm 5V \leq V_S \leq \pm 20V$ and $-25^\circ C \leq T_A \leq +85^\circ C$ (LM201A), $\pm 5V \leq V_S \leq \pm 15V$ and $0^\circ C \leq T_A \leq +70^\circ C$ (LM301A).

Note 6: Refer to RETS101AX for LM101A military specifications and RETS101X for LM101 military specifications.

Note 7: Human body model, 100 pF discharged through 1.5 k Ω .

Typical Performance Characteristics LM101A/LM201A

Input Voltage Range

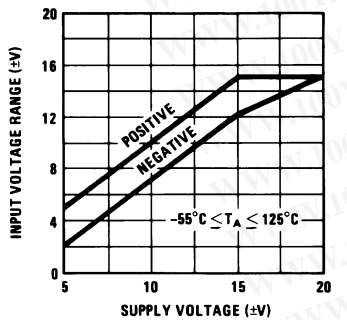

Output Swing

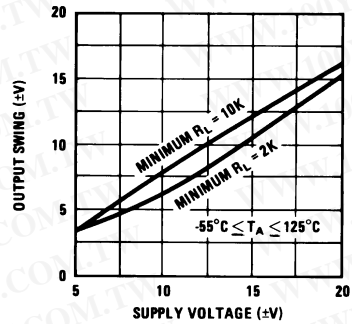

Voltage Gain

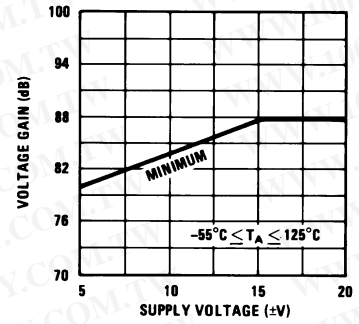

Guaranteed Performance Characteristics LM301A

Input Voltage Range

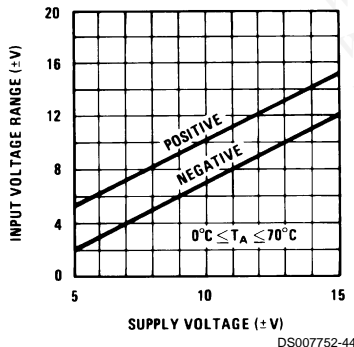

Output Swing

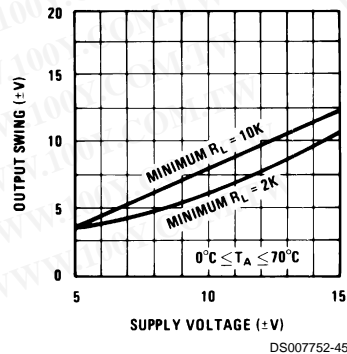

Voltage Gain

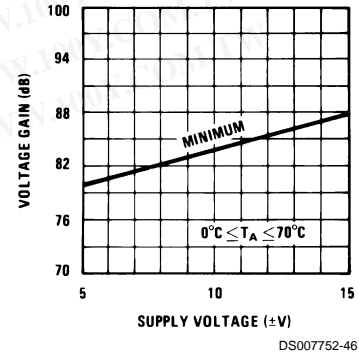

Typical Performance Characteristics

Supply Current

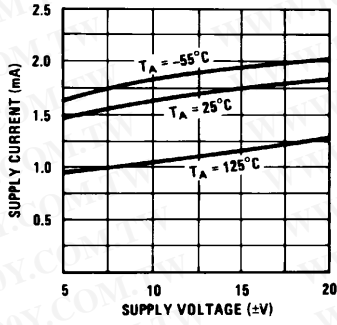

DS007752-47

Voltage Gain

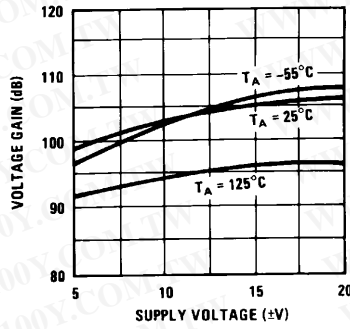

DS007752-48

Maximum Power Dissipation

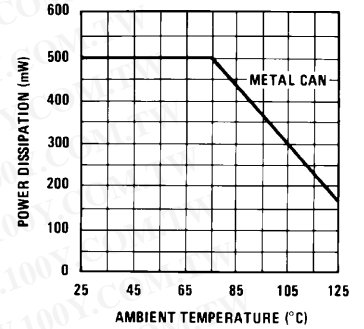

DS007752-49

Input Current, LM101A/LM201A/LM301A

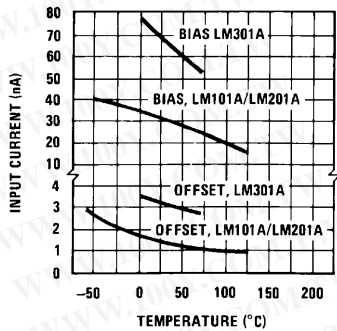

DS007752-50

Current Limiting

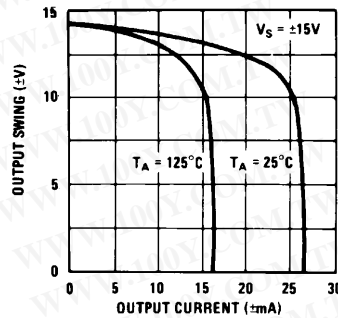

DS007752-51

Input Noise Voltage

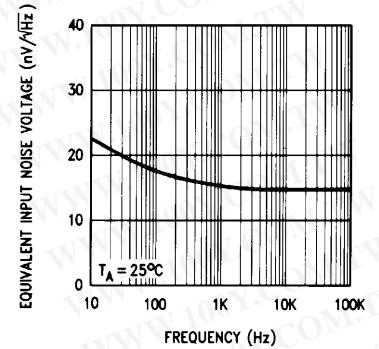

DS007752-52

Input Noise Current

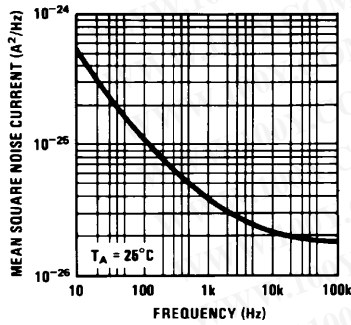

DS007752-53

Common Mode Rejection

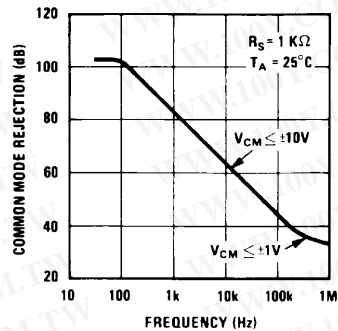

DS007752-54

Power Supply Rejection

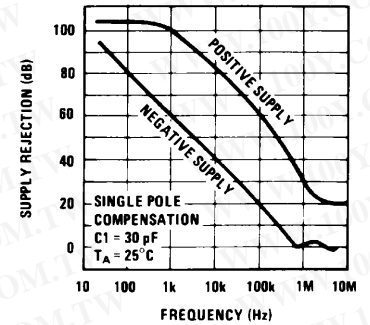

DS007752-55

勝特力材料 886-3-5753170
 勝特力电子(上海) 86-21-54151736
 勝特力电子(深圳) 86-755-83298787
[Http://www.100y.com.tw](http://www.100y.com.tw)

勝特力材料 886-3-5753170
 勝特力电子(上海) 86-21-54151736
 勝特力电子(深圳) 86-755-83298787
[Http://www.100y.com.tw](http://www.100y.com.tw)

LM101A/LM201A/LM301A

Typical Performance Characteristics (Continued)

Closed Loop Output Impedance

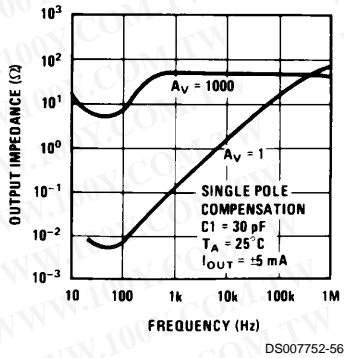

Typical Performance Characteristics for Various Compensation Circuits (Note 9)

Single Pole Compensation

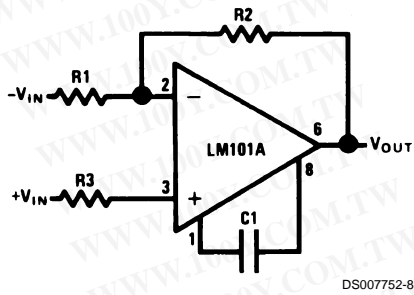

$$C1 \geq \frac{R1 C_S}{R1 + R2}$$

$$C_S = 30 \text{ pF}$$

Two Pole Compensation

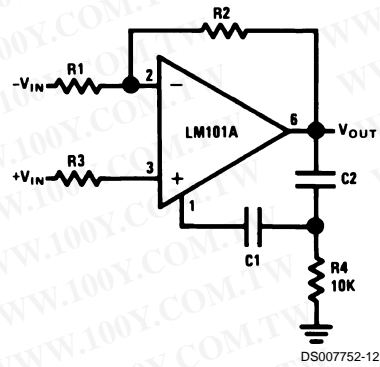

$$C1 \geq \frac{R1 C_S}{R1 + R2}$$

$$C_S = 30 \text{ pF}$$

$$C2 = 10 C1$$

Feedforward Compensation

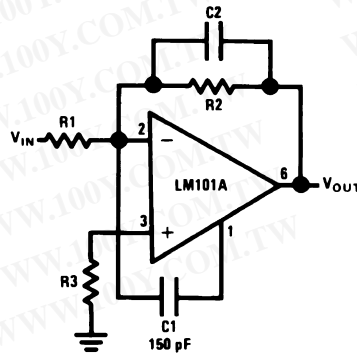

$$C2 = \frac{1}{2\pi f_0 R2}$$

$$f_0 = 3 \text{ MHz}$$

Typical Performance Characteristics for Various Compensation Circuits

(Note 9) (Continued)

Open Loop Frequency Response

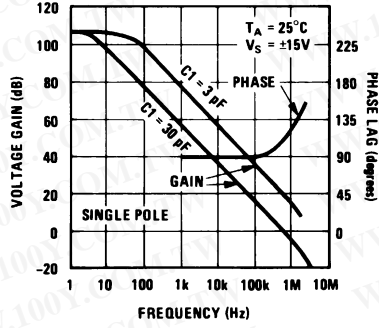

DS007752-9

Open Loop Frequency Response

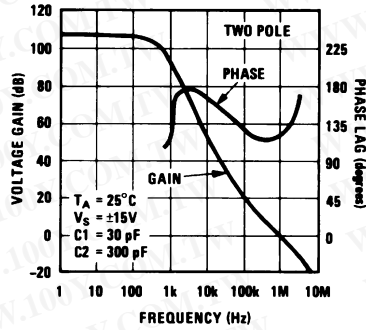

DS007752-13

Open Loop Frequency Response

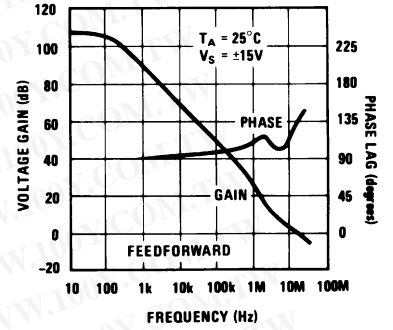

DS007752-17

Large Signal Frequency Response

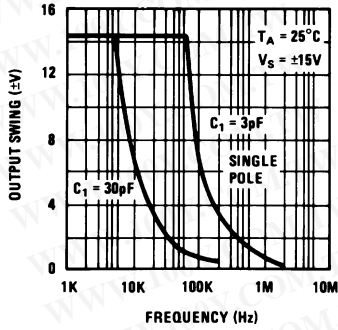

DS007752-10

Large Signal Frequency Response

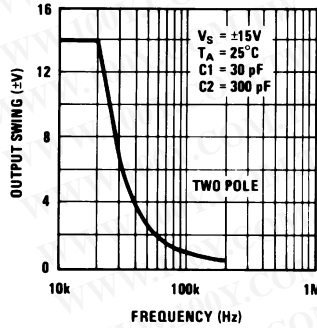

DS007752-14

Large Signal Frequency Response

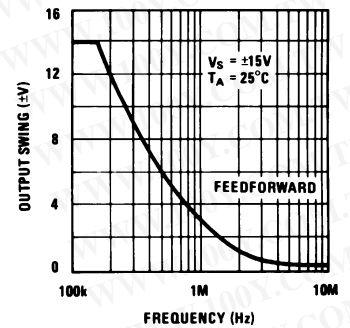

DS007752-18

Voltage Follower Pulse Response

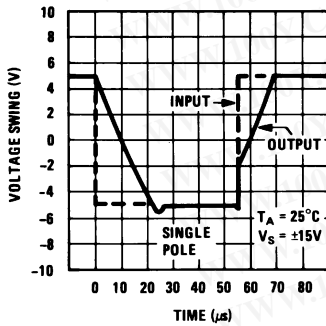

DS007752-11

Voltage Follower Pulse Response

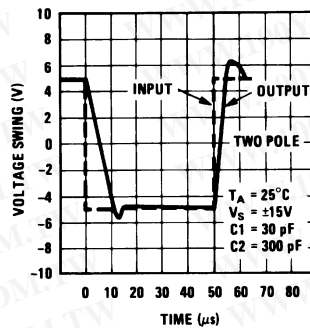

DS007752-15

Inverter Pulse Response

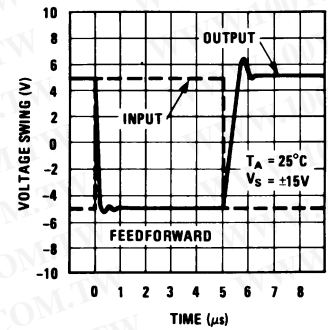

DS007752-19

勝特力材料 886-3-5753170
 勝特力电子(上海) 86-21-54151736
 勝特力电子(深圳) 86-755-83298787
[Http://www.100y.com.tw](http://www.100y.com.tw)

Typical Applications (Note 9)

Variable Capacitance Multiplier

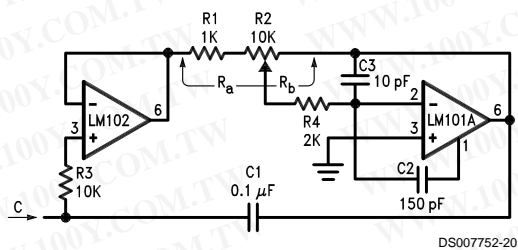

DS007752-20

$$C = 1 + \frac{R_b}{R_a} C_1$$

$$L = R_1 R_2 C_1$$

$$R_s = R_2$$

$$R_p = R_1$$

Simulated Inductor

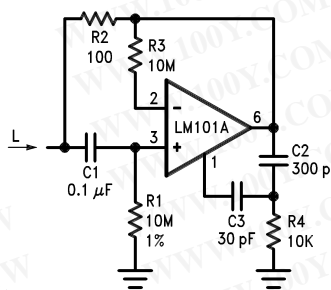

DS007752-21

Fast Inverting Amplifier with High Input Impedance

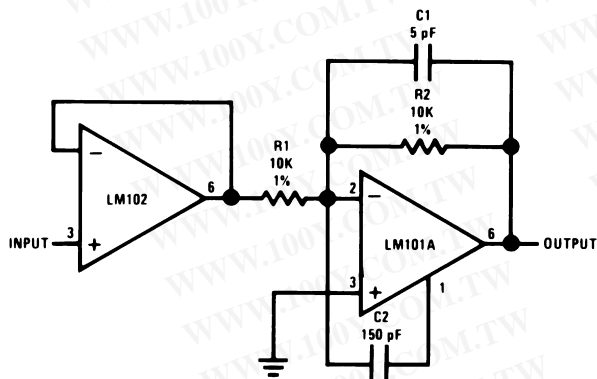

DS007752-22

Inverting Amplifier with Balancing Circuit

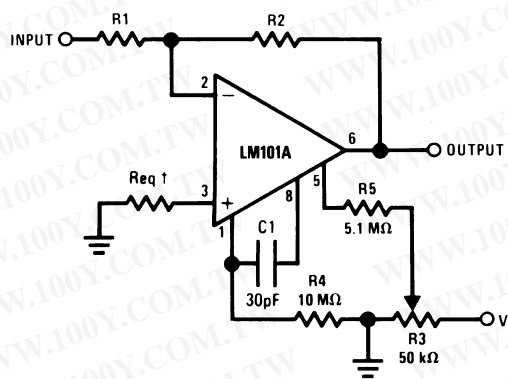

DS007752-23

†May be zero or equal to parallel combination of R1 and R2 for minimum offset.

Sine Wave Oscillator

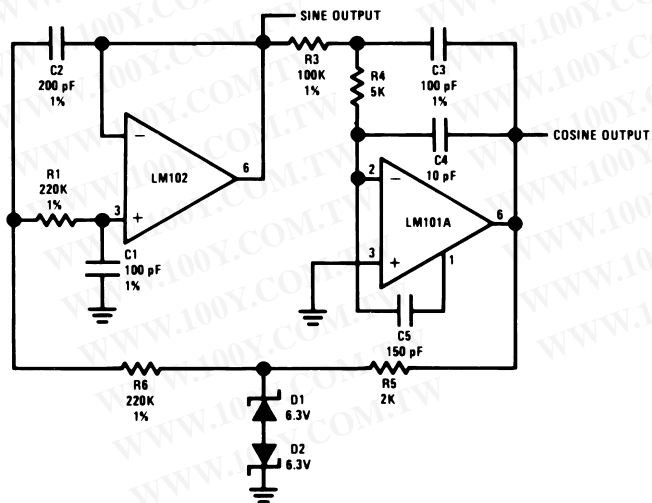

DS007752-24

$$f_o = 10 \text{ kHz}$$

Typical Applications (Note 9) (Continued)

Integrator with Bias Current Compensation

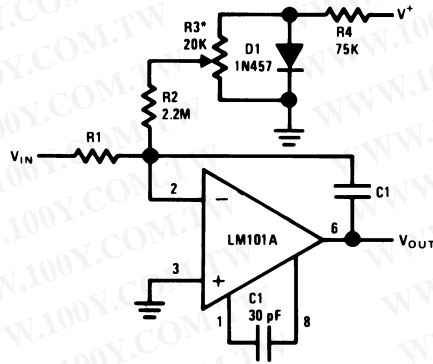

DS007752-25

*Adjust for zero integrator drift. Current drift typically 0.1 nA/°C over -55°C to +125°C temperature range.

Application Hints (Note 9)

Protecting Against Gross Fault Conditions

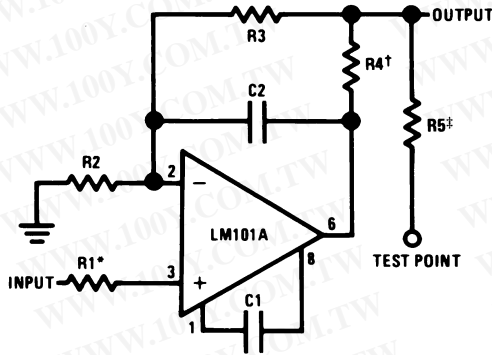

DS007752-26

*Protects input
 †Protects output

‡Protects output — not needed when R4 is used.

Compensating for Stray Input Capacitances or Large Feedback Resistor

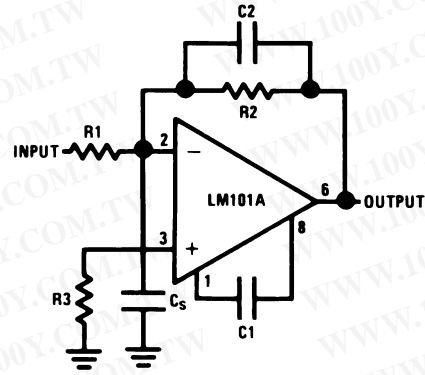

DS007752-27

$$C2 = \frac{R1 C_s}{R2}$$

Isolating Large Capacitive Loads

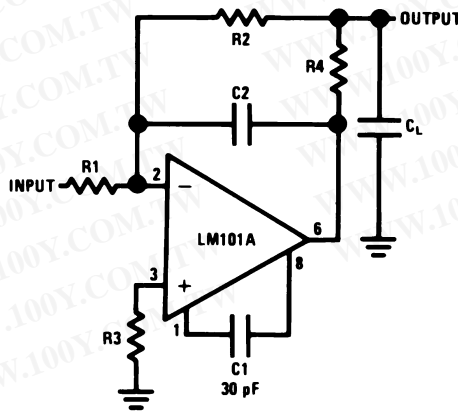

DS007752-28

Although the LM101A is designed for trouble free operation, experience has indicated that it is wise to observe certain precautions given below to protect the devices from abnormal operating conditions. It might be pointed out that the ad-

vice given here is applicable to practically any IC op amp, although the exact reason why may differ with different devices.

Application Hints (Note 9) (Continued)

When driving either input from a low-impedance source, a limiting resistor should be placed in series with the input lead to limit the peak instantaneous output current of the source to something less than 100 mA. This is especially important when the inputs go outside a piece of equipment where they could accidentally be connected to high voltage sources. Large capacitors on the input (greater than 0.1 μF) should be treated as a low source impedance and isolated with a resistor. Low impedance sources do not cause a problem unless their output voltage exceeds the supply voltage. However, the supplies go to zero when they are turned off, so the isolation is usually needed.

The output circuitry is protected against damage from shorts to ground. However, when the amplifier output is connected to a test point, it should be isolated by a limiting resistor, as test points frequently get shorted to bad places. Further, when the amplifier drives a load external to the equipment, it is also advisable to use some sort of limiting resistance to preclude mishaps.

Precautions should be taken to insure that the power supplies for the integrated circuit never become reversed—even under transient conditions. With reverse voltages greater than 1V, the IC will conduct excessive cur-

rent, fusing internal aluminum interconnects. If there is a possibility of this happening, clamp diodes with a high peak current rating should be installed on the supply lines. Reversal of the voltage between V^+ and V^- will always cause a problem, although reversals with respect to ground may also give difficulties in many circuits.

The minimum values given for the frequency compensation capacitor are stable only for source resistances less than 10 $\text{k}\Omega$, stray capacitances on the summing junction less than 5 pF and capacitive loads smaller than 100 pF. If any of these conditions are not met, it becomes necessary to over-compensate the amplifier with a larger compensation capacitor. Alternately, lead capacitors can be used in the feedback network to negate the effect of stray capacitance and large feedback resistors or an RC network can be added to isolate capacitive loads.

Although the LM101A is relatively unaffected by supply bypassing, this cannot be ignored altogether. Generally it is necessary to bypass the supplies to ground at least once on every circuit card, and more bypass points may be required if more than five amplifiers are used. When feed-forward compensation is employed, however, it is advisable to bypass the supply leads of each amplifier with low inductance capacitors because of the higher frequencies involved.

Typical Applications (Note 9)

Standard Compensation and Offset Balancing Circuit

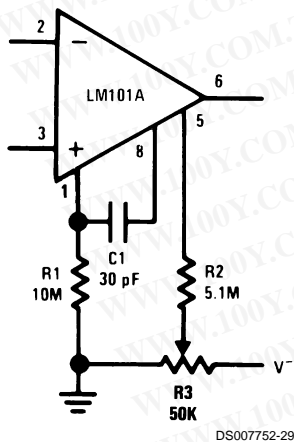

Fast Voltage Follower

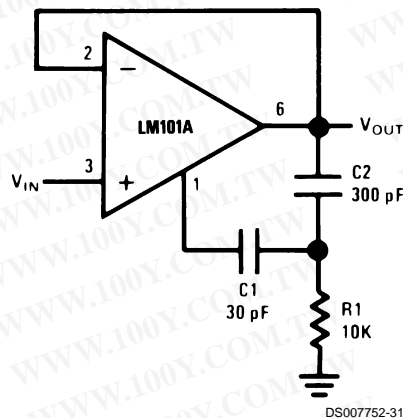

Power Bandwidth: 15 kHz
Slew Rate: 1V/ μs

勝特力材料 886-3-5753170
勝特力电子(上海) 86-21-54151736
勝特力电子(深圳) 86-755-83298787
[Http://www.100y.com.tw](http://www.100y.com.tw)

Typical Applications (Note 9) (Continued)

Fast Summing Amplifier

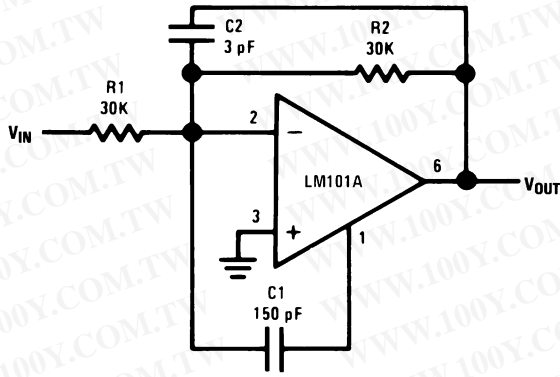

DS007752-30

Power Bandwidth: 250 kHz
 Small Signal Bandwidth: 3.5 MHz
 Slew Rate: 10V/μs

Bilateral Current Source

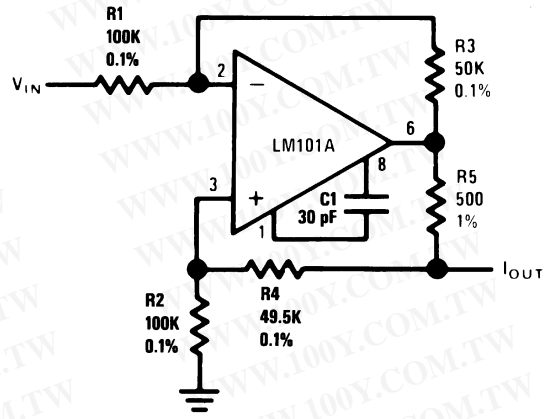

DS007752-32

$$I_{OUT} = \frac{R_3 V_{IN}}{R_1 R_5}$$

$$R_3 = R_4 + R_5$$

$$R_1 = R_2$$

Fast AC/DC Converter (Note 8)

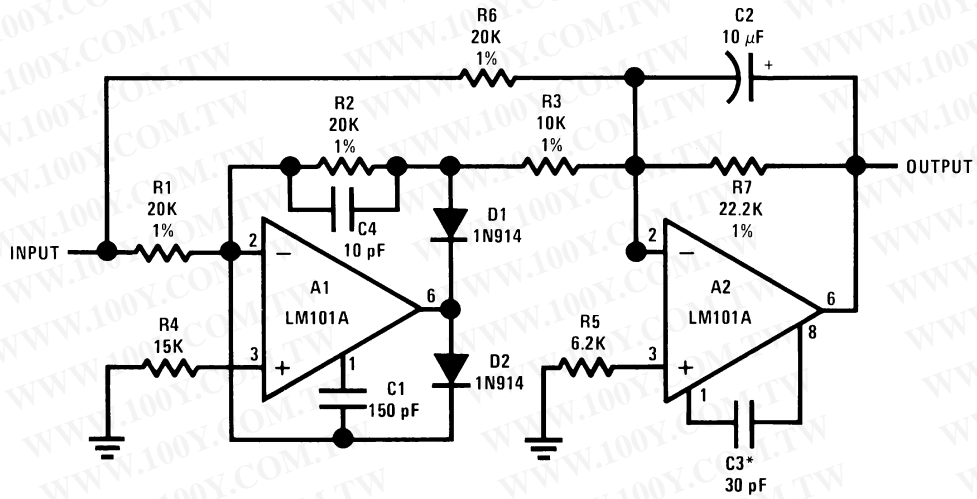

DS007752-33

Note 8: Feedforward compensation can be used to make a fast full wave rectifier without a filter.

Typical Applications (Note 9) (Continued)

Instrumentation Amplifier

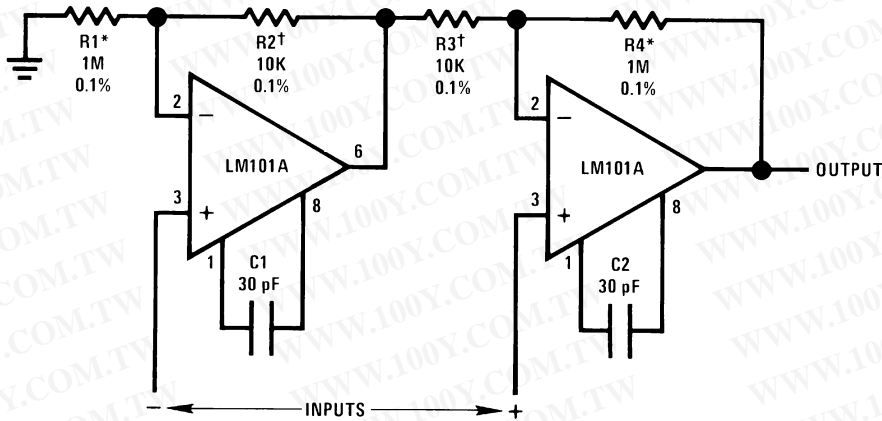

DS007752-34

$R1 = R4; R2 = R3$

$$A_V = 1 + \frac{R1}{R2}$$

* , † Matching determines CMRR.

Integrator with Bias Current Compensation

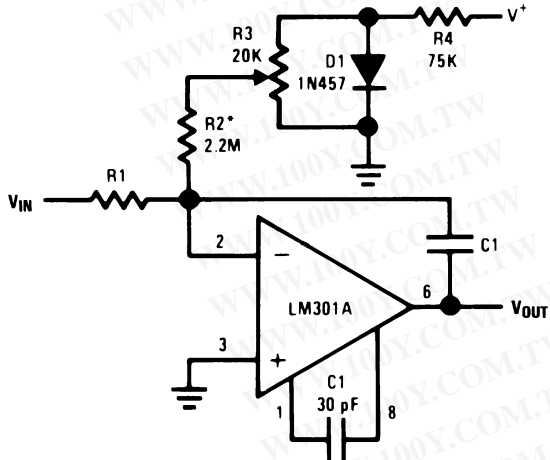

DS007752-35

*Adjust for zero integrator drift. Current drift typically 0.1 nA/°C over 0°C to +70°C temperature range.

Voltage Comparator for Driving RTL Logic or High Current Driver

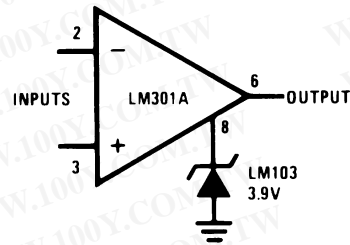

DS007752-37

Typical Applications (Note 9) (Continued)

勝特力材料 886-3-5753170
 勝特力电子(上海) 86-21-54151736
 勝特力电子(深圳) 86-755-83298787
[Http://www.100y.com.tw](http://www.100y.com.tw)

Low Frequency Square Wave Generator

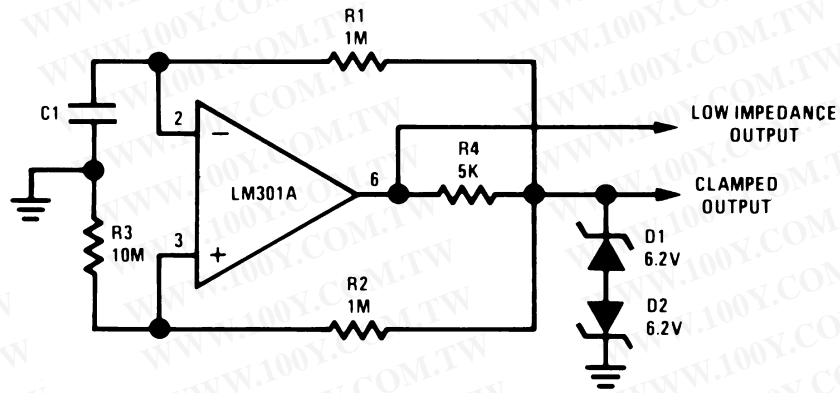

DS007752-36

Low Drift Sample and Hold

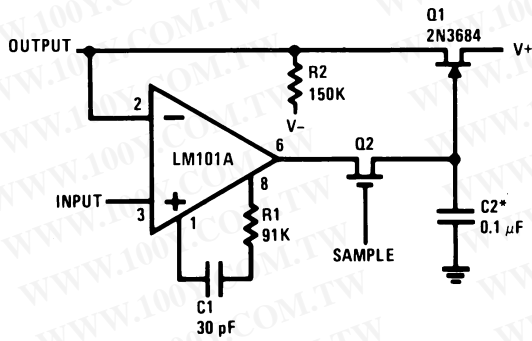

DS007752-38

*Polycarbonate-dielectric capacitor

Voltage Comparator for Driving DTL or TTL Integrated Circuits

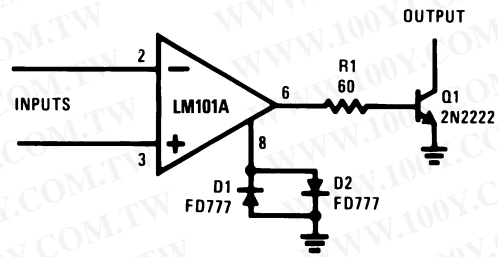

DS007752-39

勝特力材料 886-3-5753170
 勝特力电子(上海) 86-21-54151736
 勝特力电子(深圳) 86-755-83298787
[Http://www.100y.com.tw](http://www.100y.com.tw)

LM101A/LM201A/LM301A

Schematic (Note 9)

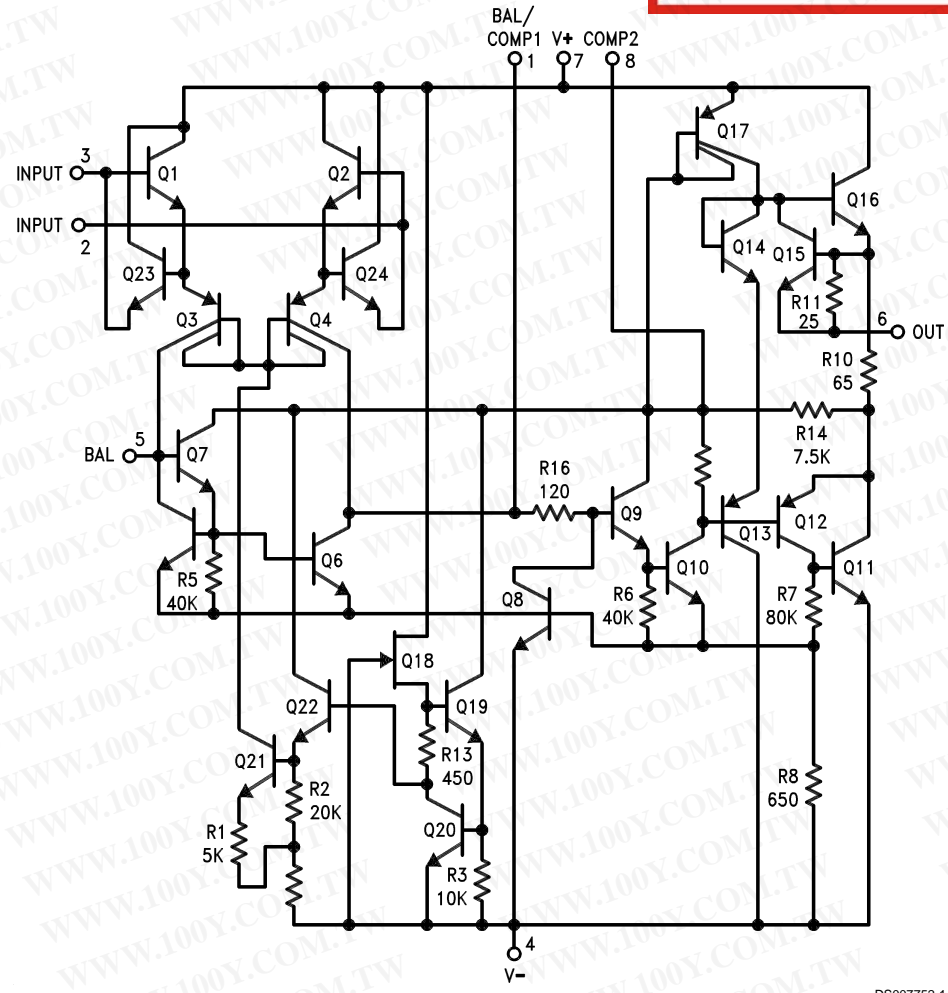

DS007752-1

Note 9: Pin connections shown are for 8-pin packages.

Connection Diagrams (Top View)

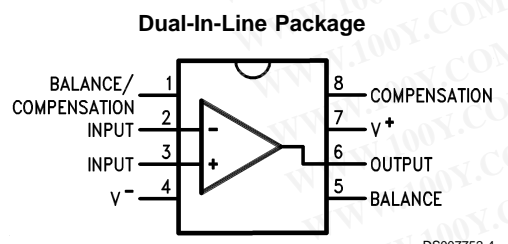

DS007752-4

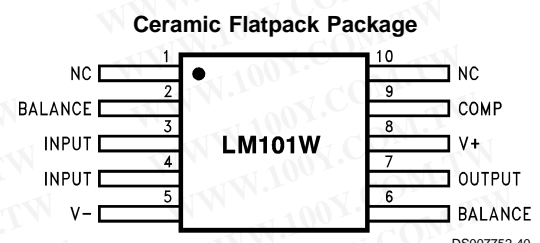

DS007752-40

Order Number LM101AJ, LM101J/883 (Note 10),
 LM201AN or LM301AN
 See NS Package Number J08A or N08E

Order Number LM101AW/883 or LM101W/883
 See NS Package Number W10A

Connection Diagrams (Top View) (Continued)

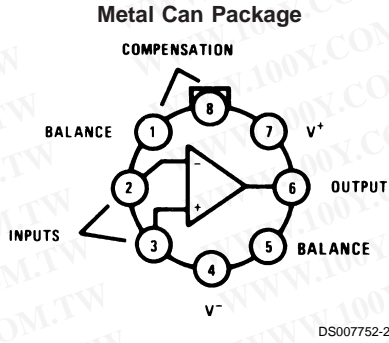

Note: Pin 4 connected to case.

Order Number LM101AH, LM101AH/883 (Note 10),
LM201AH or LM301AH
See NS Package Number H08C

Note 10: Available per JM38510/10103.

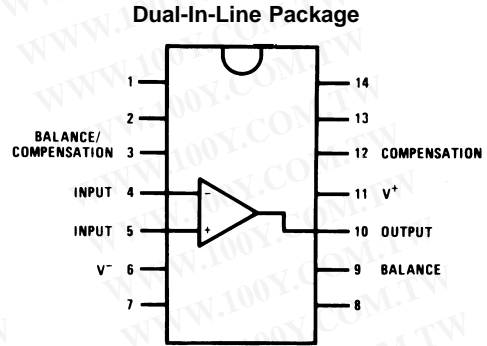

Order Number LM101AJ-14/883 (Note 10)
See NS Package Number J14A

勝特力材料 886-3-5753170
勝特力电子(上海) 86-21-54151736
勝特力电子(深圳) 86-755-83298787
[Http://www.100y.com.tw](http://www.100y.com.tw)

Physical Dimensions inches (millimeters) unless otherwise noted

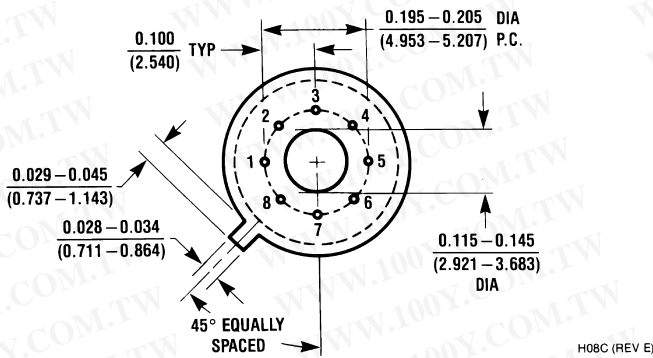
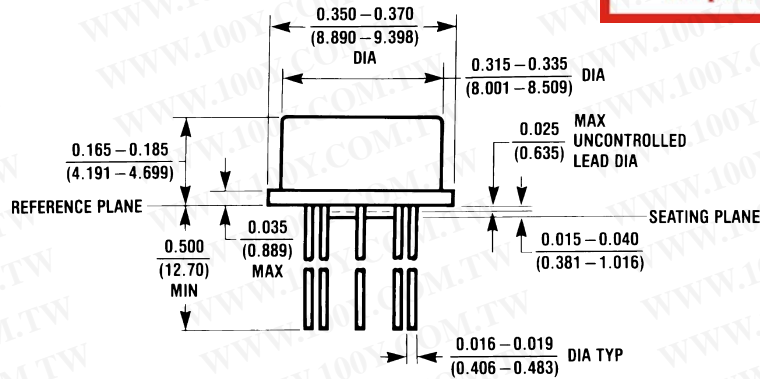

Metal Can Package (H)
 Order Number LM101AH, LM101AH/883
 LM201AH or LM301AH
 NS Package Number H08C

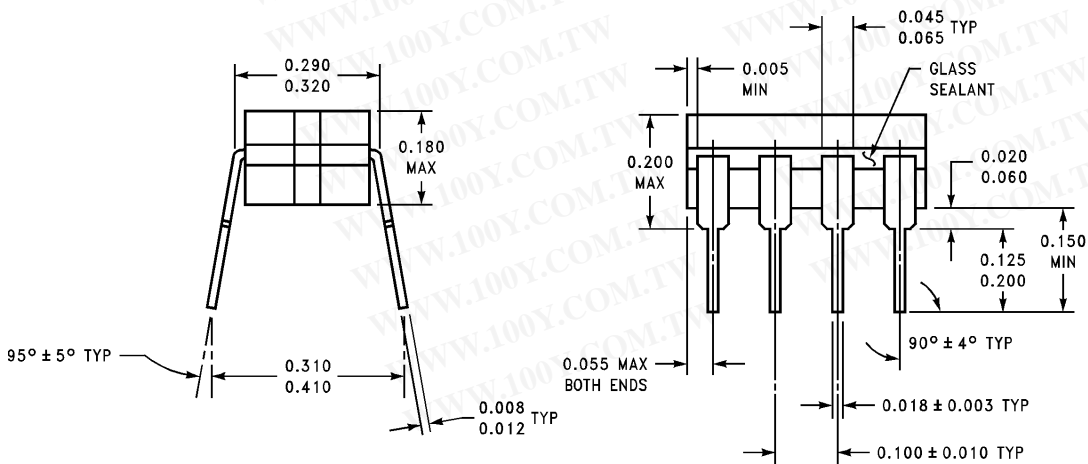
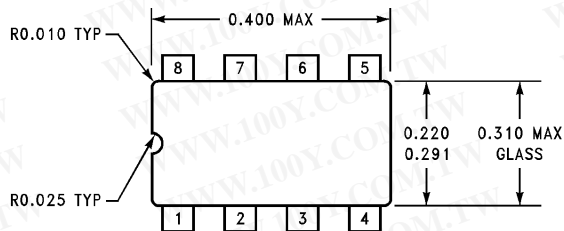

Ceramic Dual-In-Line Package (J)
 Order Number LM101J/883 or LM101AJ
 NS Package Number J08A

Physical Dimensions inches (millimeters) unless otherwise noted (Continued)

勝特力材料 886-3-5753170
 勝特力电子(上海) 86-21-54151736
 勝特力电子(深圳) 86-755-83298787
[Http://www.100y.com.tw](http://www.100y.com.tw)

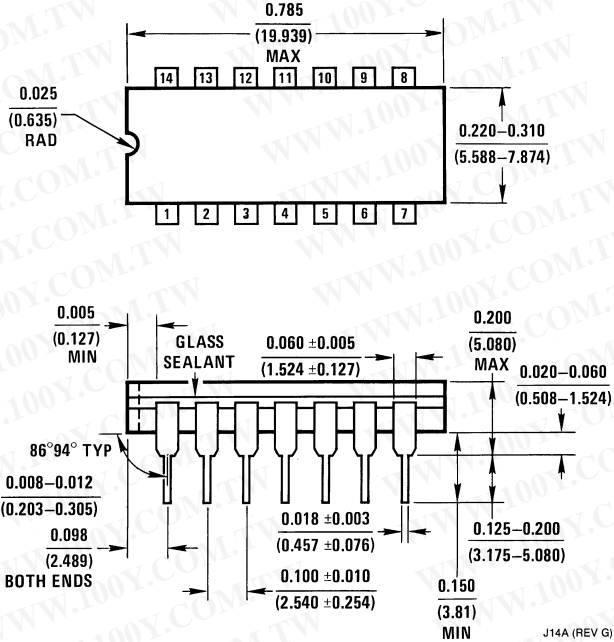

Ceramic Dual-In-Line Package (J)
 Order Number LM101AJ-14/883
 NS Package Number J14A

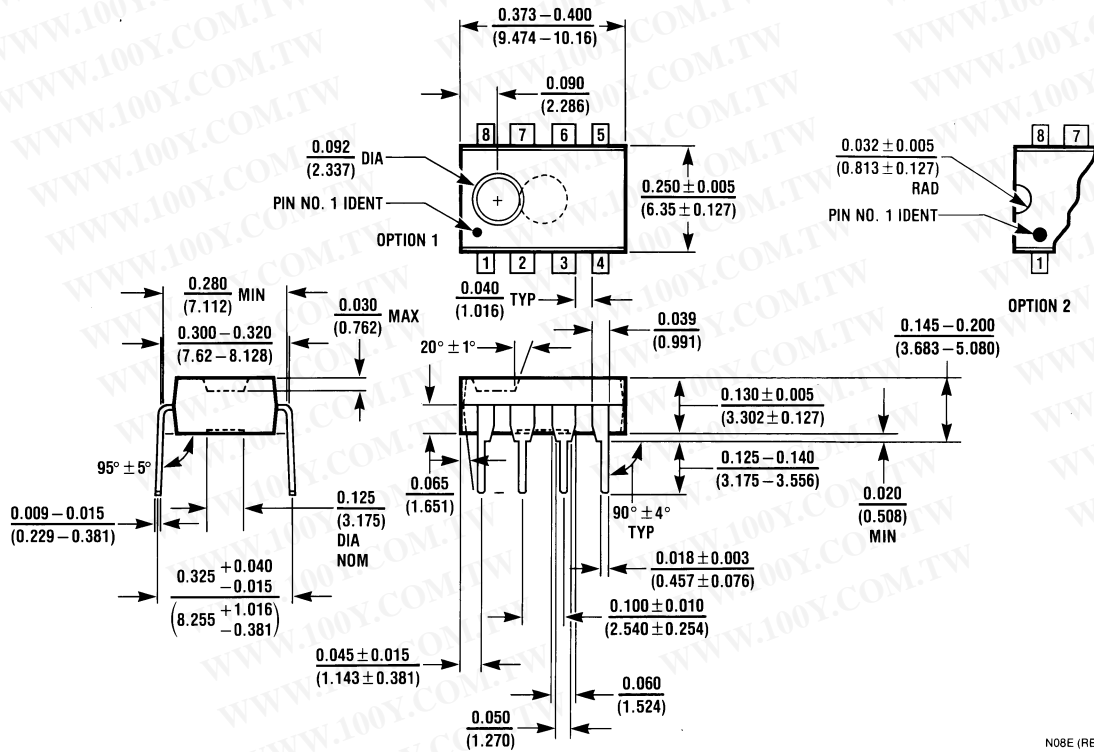

Molded Dual-In-Line Package (N)
 Order Number LM201AN or LM301AN
 NS Package Number N08E

Physical Dimensions inches (millimeters) unless otherwise noted (Continued)

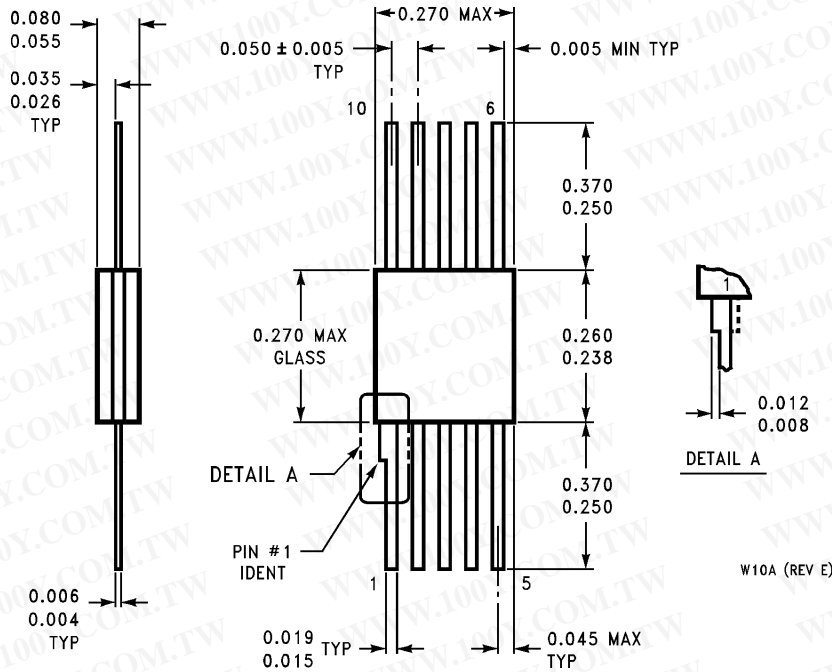

Ceramic Flatpack Package (W)
Order Number LM101AW/883 or LM101W/883
NS Package Number W10A

勝特力材料 886-3-5753170
勝特力电子(上海) 86-21-54151736
勝特力电子(深圳) 86-755-83298787
[Http://www.100y.com.tw](http://www.100y.com.tw)

LIFE SUPPORT POLICY

NATIONAL'S PRODUCTS ARE NOT AUTHORIZED FOR USE AS CRITICAL COMPONENTS IN LIFE SUPPORT DEVICES OR SYSTEMS WITHOUT THE EXPRESS WRITTEN APPROVAL OF THE PRESIDENT AND GENERAL COUNSEL OF NATIONAL SEMICONDUCTOR CORPORATION. As used herein:

1. Life support devices or systems are devices or systems which, (a) are intended for surgical implant into the body, or (b) support or sustain life, and whose failure to perform when properly used in accordance with instructions for use provided in the labeling, can be reasonably expected to result in a significant injury to the user.
2. A critical component is any component of a life support device or system whose failure to perform can be reasonably expected to cause the failure of the life support device or system, or to affect its safety or effectiveness.

National Semiconductor Corporation
 Americas
 Tel: 1-800-272-9959
 Fax: 1-800-737-7018
 Email: support@nsc.com
www.national.com

National Semiconductor Europe
 Fax: +49 (0) 180-530 85 86
 Email: europe.support@nsc.com
 Deutsch Tel: +49 (0) 69 9508 6208
 English Tel: +44 (0) 870 24 0 2171
 Français Tel: +33 (0) 1 41 91 87 90

National Semiconductor Asia Pacific Customer Response Group
 Tel: 65-2544466
 Fax: 65-2504466
 Email: ap.support@nsc.com

National Semiconductor Japan Ltd.
 Tel: 81-3-5639-7560
 Email: nsj.crc@jksmtp.nsc.com
 Fax: 81-3-5639-7507