



May 1998

# LM10

## Operational Amplifier and Voltage Reference

### General Description

The LM10 series are monolithic linear ICs consisting of a precision reference, an adjustable reference buffer and an independent, high quality op amp.

The unit can operate from a total supply voltage as low as 1.1V or as high as 40V, drawing only 270 $\mu$ A. A complementary output stage swings within 15 mV of the supply terminals or will deliver  $\pm 20$  mA output current with  $\pm 0.4$ V saturation. Reference output can be as low as 200 mV.

The circuit is recommended for portable equipment and is completely specified for operation from a single power cell. In contrast, high output-drive capability, both voltage and current, along with thermal overload protection, suggest it in demanding general-purpose applications.

The device is capable of operating in a floating mode, independent of fixed supplies. It can function as a remote comparator, signal conditioner, SCR controller or transmitter for

analog signals, delivering the processed signal on the same line used to supply power. It is also suited for operation in a wide range of voltage- and current-regulator applications, from low voltages to several hundred volts, providing greater precision than existing ICs.

This series is available in the three standard temperature ranges, with the commercial part having relaxed limits. In addition, a low-voltage specification (suffix "L") is available in the limited temperature ranges at a cost savings.

### Features

- input offset voltage: 2.0 mV (max)
- input offset current: 0.7 nA (max)
- input bias current: 20 nA (max)
- reference regulation: 0.1% (max)
- offset voltage drift: 2 $\mu$ V/ $^{\circ}$ C
- reference drift: 0.002%/ $^{\circ}$ C

### Connection and Functional Diagrams

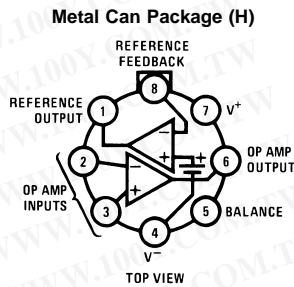

Order Number LM10BH, LM10CH, LM10CLH or LM10H/883  
available per SMA# 5962-8760401  
See NS Package Number H08A

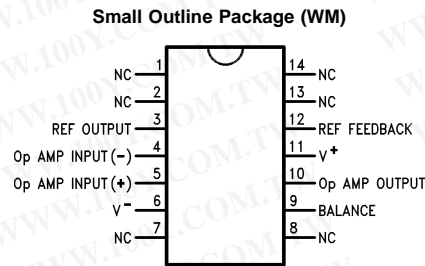

Order Number LM10CWM  
See NS Package Number M14B

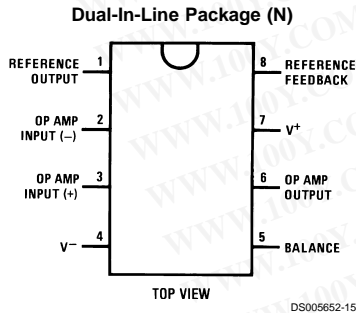

Order Number LM10CN or LM10CLN  
See NS Package Number N08E

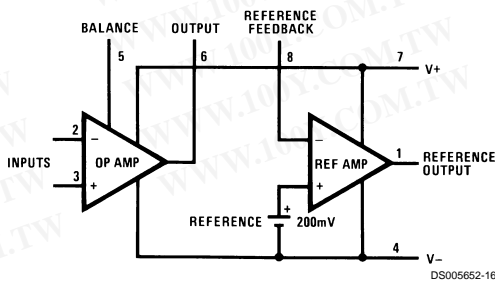

LM10 Operational Amplifier and Voltage Reference

### Absolute Maximum Ratings (Notes 1, 8)

If Military/Aerospace specified devices are required, please contact the National Semiconductor Sales Office/Distributors for availability and specifications.

	LM10/LM10B/ LM10BL/	
	LM10C	LM10CL
Total Supply Voltage	45V	7V
Differential Input Voltage (Note 2)	±40V	±7V
Power Dissipation (Note 3)	internally limited	
Output Short-circuit Duration (Note 4)	continuous	
Storage-Temp. Range	-55°C to +150°C	
Lead Temp. (Soldering, 10 seconds)		
Metal Can	300°C	
Lead Temp. (Soldering, 10 seconds) DIP	260°C	
Vapor Phase (60 seconds)	215°C	
Infrared (15 seconds)	220°C	

See AN-450 "Surface Mounting Methods and Their Effect on Product Reliability" for other methods of soldering surface mount devices.

### Electrical Characteristics

$T_J = 25^\circ\text{C}$ ,  $T_{\text{MIN}} \leq T_J \leq T_{\text{MAX}}$  (Boldface type refers to limits over temperature range) (Note 5)

Parameter	Conditions	LM10/LM10B			LM10C			Units
		Min	Typ	Max	Min	Typ	Max	
Input offset voltage			0.3	2.0		0.5	4.0	mV
				<b>3.0</b>			<b>5.0</b>	mV
Input offset current (Note 6)			0.25	0.7		0.4	2.0	nA
				<b>1.5</b>			<b>3.0</b>	nA
Input bias current			10	20		12	30	nA
				<b>30</b>			<b>40</b>	nA
Input resistance		250	500		150	400		k $\Omega$
		<b>150</b>			<b>115</b>			k $\Omega$
Large signal voltage gain	$V_S = \pm 20\text{V}$ , $I_{\text{OUT}} = 0$	120	400		80	400		V/mV
	$V_{\text{OUT}} = \pm 19.95\text{V}$	<b>80</b>			<b>50</b>			V/mV
	$V_S = \pm 20\text{V}$ , $V_{\text{OUT}} = \pm 19.4\text{V}$	50	130		25	130		V/mV
	$I_{\text{OUT}} = \pm 20\text{ mA}$ ( <b><math>\pm 15\text{ mA}</math></b> )	<b>20</b>			<b>15</b>			V/mV
	$V_S = \pm 0.6\text{V}$ ( <b><math>0.65\text{V}</math></b> ), $I_{\text{OUT}} = \pm 2\text{ mA}$	1.5	3.0		1.0	3.0		V/mV
	$V_{\text{OUT}} = \pm 0.4\text{V}$ ( <b><math>\pm 0.3\text{V}</math></b> ), $V_{\text{CM}} = -0.4\text{V}$	<b>0.5</b>			<b>0.75</b>			V/mV
Shunt gain (Note 7)	$1.2\text{V}$ ( <b><math>1.3\text{V}</math></b> ) $\leq V_{\text{OUT}} \leq 40\text{V}$ , $R_L = 1.1\text{ k}\Omega$	14	33		10	33		V/mV
	$0.1\text{ mA} \leq I_{\text{OUT}} \leq 5\text{ mA}$	<b>6</b>			<b>6</b>			V/mV
	$1.5\text{V} \leq V^+ \leq 40\text{V}$ , $R_L = 250\Omega$	8	25		6	25		V/mV
	$0.1\text{ mA} \leq I_{\text{OUT}} \leq 20\text{ mA}$	<b>4</b>			<b>4</b>			V/mV
Common-mode rejection	$-20\text{V} \leq V_{\text{CM}} \leq 19.15\text{V}$ ( <b><math>19\text{V}</math></b> ) $V_S = \pm 20\text{V}$	93	102		90	102		dB
		<b>87</b>			<b>87</b>			dB
Supply-voltage rejection	$-0.2\text{V} \geq V^- \geq -39\text{V}$	90	96		87	96		dB
	$V^+ = 1.0\text{V}$ ( <b><math>1.1\text{V}</math></b> )	<b>84</b>			<b>84</b>			dB
	$1.0\text{V}$ ( <b><math>1.1\text{V}</math></b> ) $\leq V^+ \leq 39.8\text{V}$	96	106		93	106		dB
	$V^- = -0.2\text{V}$	<b>90</b>			<b>90</b>			dB
Offset voltage drift			2.0			5.0		$\mu\text{V}/^\circ\text{C}$
Offset current drift			2.0			5.0		$\text{pA}/^\circ\text{C}$
Bias current drift	$T_C \leq 100^\circ\text{C}$		60			90		$\text{pA}/^\circ\text{C}$
Line regulation	$1.2\text{V}$ ( <b><math>1.3\text{V}</math></b> ) $\leq V_S \leq 40\text{V}$		0.001	0.003		0.001	0.008	%/V
	$0 \leq I_{\text{REF}} \leq 1.0\text{ mA}$ , $V_{\text{REF}} = 200\text{ mV}$			<b>0.006</b>			<b>0.01</b>	%/V

ESD rating is to be determined.

Maximum Junction Temperature

LM10	150°C
LM10B	100°C
LM10C	85°C

### Operating Ratings

Package Thermal Resistance

$\theta_{\text{JA}}$		
H Package		150°C/W
N Package		87°C/W
WM Package		90°C/W
$\theta_{\text{JC}}$		
H Package		45°C/W

### Electrical Characteristics (Continued)

$T_J=25^{\circ}\text{C}$ ,  $T_{\text{MIN}} \leq T_J \leq T_{\text{MAX}}$  (Boldface type refers to limits over temperature range) (Note 5)

Parameter	Conditions	LM10/LM10B			LM10C			Units
		Min	Typ	Max	Min	Typ	Max	
Load regulation	$0 \leq I_{\text{REF}} \leq 1.0 \text{ mA}$		0.01	0.1		0.01	0.15	%
	$V^+ - V_{\text{REF}} \geq 1.0\text{V}$ ( <b>1.1V</b> )			<b>0.15</b>			<b>0.2</b>	%
Amplifier gain	$0.2\text{V} \leq V_{\text{REF}} \leq 35\text{V}$	50	75		25	70		V/mV
		<b>23</b>			<b>15</b>			V/mV
Feedback sense voltage		195	200	205	190	200	210	mV
		<b>194</b>		<b>206</b>	<b>189</b>		<b>211</b>	mV
Feedback current			20	50		22	75	nA
				<b>65</b>			<b>90</b>	nA
Reference drift			0.002			0.003		%/°C
Supply current			270	400		300	500	μA
				<b>500</b>			<b>570</b>	μA
Supply current change	$1.2\text{V}$ ( <b>1.3V</b> ) $\leq V_S \leq 40\text{V}$		15	<b>75</b>		15	<b>75</b>	μA

### Electrical Characteristics

$T_J=25^{\circ}\text{C}$ ,  $T_{\text{MIN}} \leq T_J \leq T_{\text{MAX}}$  (Boldface type refers to limits over temperature range) (Note 5)

Parameter	Conditions	LM10BL			LM10CL			Units
		Min	Typ	Max	Min	Typ	Max	
Input offset voltage			0.3	2.0		0.5	4.0	mV
				<b>3.0</b>			<b>5.0</b>	mV
Input offset current (Note 6)			0.1	0.7		0.2	2.0	nA
				<b>1.5</b>			<b>3.0</b>	nA
Input bias current			10	20		12	30	nA
				<b>30</b>			<b>40</b>	nA
Input resistance		250	500		150	400		kΩ
		<b>150</b>			<b>115</b>			kΩ
Large signal voltage gain	$V_S = \pm 3.25\text{V}$ , $I_{\text{OUT}} = 0$	60	300		40	300		V/mV
	$V_{\text{OUT}} = \pm 3.2\text{V}$	<b>40</b>			<b>25</b>			V/mV
	$V_S = \pm 3.25\text{V}$ , $I_{\text{OUT}} = 10 \text{ mA}$	10	25		5	25		V/mV
	$V_{\text{OUT}} = \pm 2.75 \text{ V}$	<b>4</b>			<b>3</b>			V/mV
	$V_S = \pm 0.6\text{V}$ ( <b>0.65V</b> ), $I_{\text{OUT}} = \pm 2 \text{ mA}$	1.5	3.0		1.0	3.0		V/mV
	$V_{\text{OUT}} = \pm 0.4\text{V}$ ( <b>±0.3V</b> ), $V_{\text{CM}} = -0.4\text{V}$	<b>0.5</b>			<b>0.75</b>			V/mV
Shunt gain (Note 7)	$1.5\text{V} \leq V^+ \leq 6.5\text{V}$ , $R_L = 500\Omega$	8	30		6	30		V/mV
	$0.1 \text{ mA} \leq I_{\text{OUT}} \leq 10 \text{ mA}$	<b>4</b>			<b>4</b>			V/mV
Common-mode rejection	$-3.25\text{V} \leq V_{\text{CM}} \leq 2.4\text{V}$ ( <b>2.25V</b> )	89	102		80	102		dB
	$V_S = \pm 3.25\text{V}$	<b>83</b>			<b>74</b>			dB
Supply-voltage rejection	$-0.2\text{V} \geq V^- \geq -5.4\text{V}$	86	96		80	96		dB
	$V^+ = 1.0\text{V}$ ( <b>1.2V</b> )	<b>80</b>			<b>74</b>			dB
	$1.0\text{V}$ ( <b>1.1V</b> ) $\leq V^+ \leq 6.3\text{V}$	94	106		80	106		dB
	$V^- = 0.2\text{V}$	<b>88</b>			<b>74</b>			dB
Offset voltage drift			2.0			5.0		μV/°C
Offset current drift			2.0			5.0		pA/°C
Bias current drift			60			90		pA/°C
Line regulation	$1.2\text{V}$ ( <b>1.3V</b> ) $\leq V_S \leq 6.5\text{V}$		0.001	0.01		0.001	0.02	%/V
	$0 \leq I_{\text{REF}} \leq 0.5 \text{ mA}$ , $V_{\text{REF}} = 200 \text{ mV}$			<b>0.02</b>			<b>0.03</b>	%/V
Load regulation	$0 \leq I_{\text{REF}} \leq 0.5 \text{ mA}$		0.01	0.1		0.01	0.15	%
	$V^+ - V_{\text{REF}} \geq 1.0\text{V}$ ( <b>1.1V</b> )			<b>0.15</b>			<b>0.2</b>	%

## Electrical Characteristics (Continued)

$T_J=25^\circ\text{C}$ ,  $T_{\text{MIN}} \leq T_J \leq T_{\text{MAX}}$  (Boldface type refers to limits over temperature range) (Note 5)

Parameter	Conditions	LM10BL			LM10CL			Units
		Min	Typ	Max	Min	Typ	Max	
Amplifier gain	$0.2V \leq V_{\text{REF}} \leq 5.5V$	30	70		20	70		V/mV
		<b>20</b>			<b>15</b>			V/mV
Feedback sense voltage		195	200	205	190	200	210	mV
		<b>194</b>		<b>206</b>	<b>189</b>		<b>211</b>	mV
Feedback current			20	50		22	75	nA
				<b>65</b>			<b>90</b>	nA
Reference drift			0.002			0.003		%/°C
Supply current			260	400		280	500	μA
				<b>500</b>			<b>570</b>	μA

**Note 1:** Absolute Maximum Ratings indicate limits beyond which damage to the device may occur. Operating Ratings indicate conditions for which the device is functional, but do not guarantee specific performance limits.

**Note 2:** The Input voltage can exceed the supply voltages provided that the voltage from the input to any other terminal does not exceed the maximum differential input voltage and excess dissipation is accounted for when  $V_{\text{IN}} < V^-$ .

**Note 3:** The maximum, operating-junction temperature is  $150^\circ\text{C}$  for the LM10,  $100^\circ\text{C}$  for the LM10B(L) and  $85^\circ\text{C}$  for the LM10C(L). At elevated temperatures, devices must be derated based on package thermal resistance.

**Note 4:** Internal thermal limiting prevents excessive heating that could result in sudden failure, but the IC can be subjected to accelerated stress with a shorted output and worst-case conditions.

**Note 5:** These specifications apply for  $V^- \leq V_{\text{CM}} \leq V^+ - 0.85V$  (1.0V),  $1.2V$  (1.3V)  $< V_{\text{S}} \leq V_{\text{MAX}}$ ,  $V_{\text{REF}} = 0.2V$  and  $0 \leq I_{\text{REF}} \leq 1.0\text{ mA}$ , unless otherwise specified:  $V_{\text{MAX}} = 40V$  for the standard part and  $6.5V$  for the low voltage part. Normal typeface indicates  $25^\circ\text{C}$  limits. **Boldface type indicates limits and altered test conditions for full-temperature-range operation;** this is  $-55^\circ\text{C}$  to  $125^\circ\text{C}$  for the LM10,  $-25^\circ\text{C}$  to  $85^\circ\text{C}$  for the LM10B(L) and  $0^\circ\text{C}$  to  $70^\circ\text{C}$  for the LM10C(L). The specifications do not include the effects of thermal gradients ( $\tau_1 \approx 20\text{ ms}$ ), die heating ( $\tau_2 \approx 0.2\text{ s}$ ) or package heating. Gradient effects are small and tend to offset the electrical error (see curves).

**Note 6:** For  $T_J > 90^\circ\text{C}$ ,  $I_{\text{OS}}$  may exceed  $1.5\text{ nA}$  for  $V_{\text{CM}} = V^-$ . With  $T_J = 125^\circ\text{C}$  and  $V^- \leq V_{\text{CM}} \leq V^- + 0.1V$ ,  $I_{\text{OS}} \leq 5\text{ nA}$ .

**Note 7:** This defines operation in floating applications such as the bootstrapped regulator or two-wire transmitter. Output is connected to the  $V^+$  terminal of the IC and input common mode is referred to  $V^-$  (see typical applications). Effect of larger output-voltage swings with higher load resistance can be accounted for by adding the positive-supply rejection error.

**Note 8:** Refer to RETS10X for LM10H military specifications.

## Definition of Terms

**Input offset voltage:** That voltage which must be applied between the input terminals to bias the unloaded output in the linear region.

**Input offset current:** The difference in the currents at the input terminals when the unloaded output is in the linear region.

**Input bias current:** The absolute value of the average of the two input currents.

**Input resistance:** The ratio of the change in input voltage to the change in input current on either input with the other grounded.

**Large signal voltage gain:** The ratio of the specified output voltage swing to the change in differential input voltage required to produce it.

**Shunt gain:** The ratio of the specified output voltage swing to the change in differential input voltage required to produce it with the output tied to the  $V^+$  terminal of the IC. The load and power source are connected between the  $V^+$  and  $V^-$  terminals, and input common-mode is referred to the  $V^-$  terminal.

**Common-mode rejection:** The ratio of the input voltage range to the change in offset voltage between the extremes.

**Supply-voltage rejection:** The ratio of the specified supply-voltage change to the change in offset voltage between the extremes.

**Line regulation:** The average change in reference output voltage over the specified supply voltage range.

**Load regulation:** The change in reference output voltage from no load to that load specified.

**Feedback sense voltage:** The voltage, referred to  $V^-$ , on the reference feedback terminal while operating in regulation.

**Reference amplifier gain:** The ratio of the specified reference output change to the change in feedback sense voltage required to produce it.

**Feedback current:** The absolute value of the current at the feedback terminal when operating in regulation.

**Supply current:** The current required from the power source to operate the amplifier and reference with their outputs unloaded and operating in the linear range.

## Typical Performance Characteristics (Op Amp)

Input Current

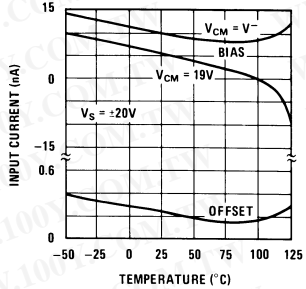

DS005652-18

Common Mode Limits

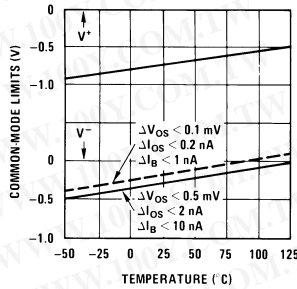

DS005652-19

Output Voltage Drift

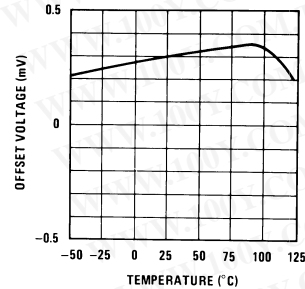

DS005652-20

Input Noise Voltage

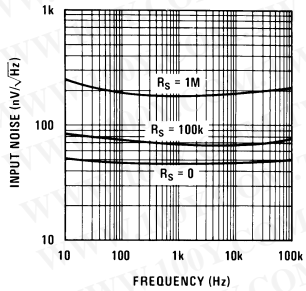

DS005652-21

DC Voltage Gain

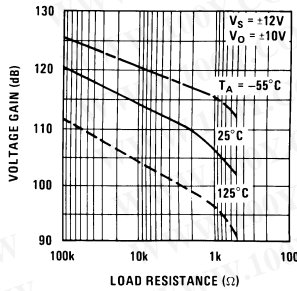

DS005652-22

Transconductance

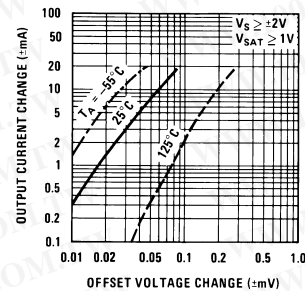

DS005652-23

Output Saturation Characteristics

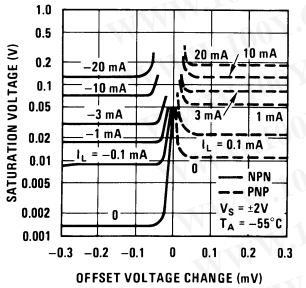

DS005652-24

Output Saturation Characteristics

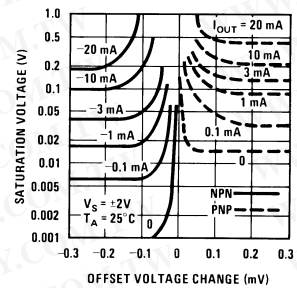

DS005652-25

Output Saturation Characteristics

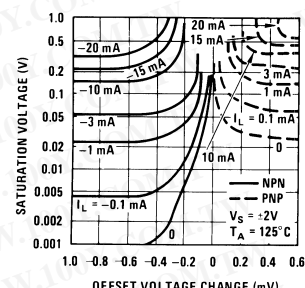

DS005652-26

### Typical Performance Characteristics (Op Amp) (Continued)

Minimum Supply Voltage

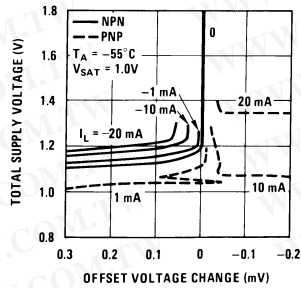

Minimum Supply Voltage

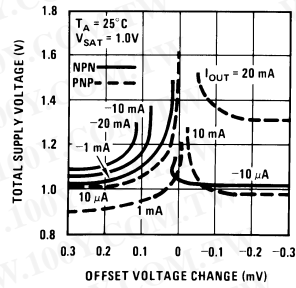

Minimum Supply Voltage

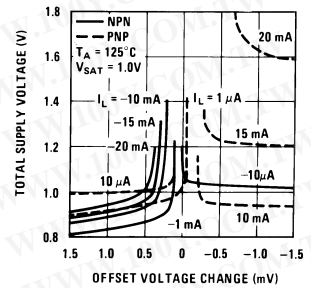

Frequency Response

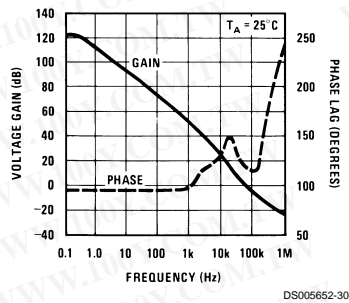

Output Impedance

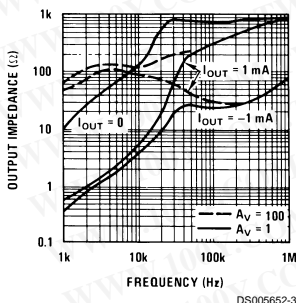

Typical Stability Range

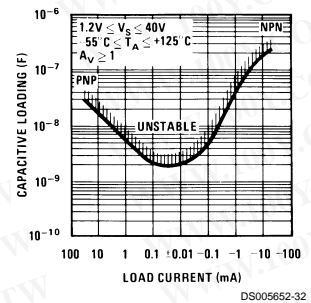

Large Signal Response

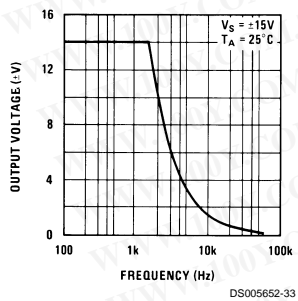

Comparator Response Time For Various Input Overdrives

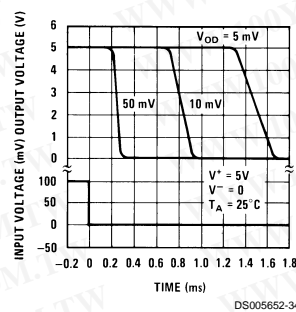

Comparator Response Time For Various Input Overdrives

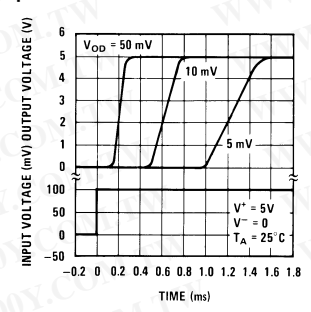

## Typical Performance Characteristics (Op Amp) (Continued)

**Follower Pulse Response**

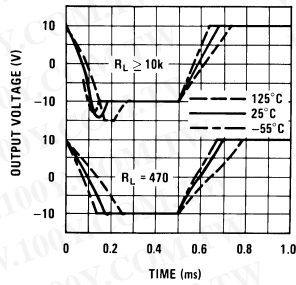

DS005652-36

**Noise Rejection**

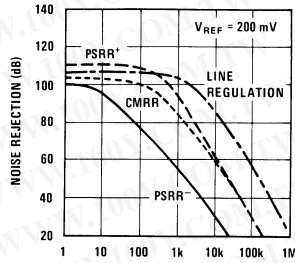

DS005652-37

**Rejection Slew Limiting**

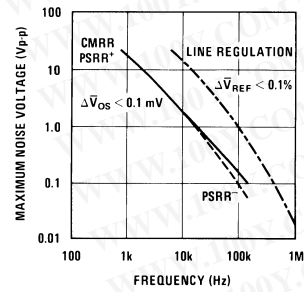

DS005652-38

**Supply Current**

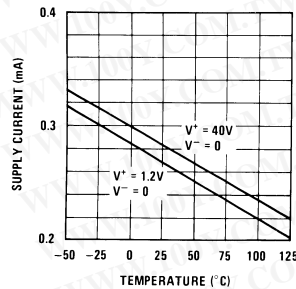

DS005652-39

**Thermal Gradient Feedback**

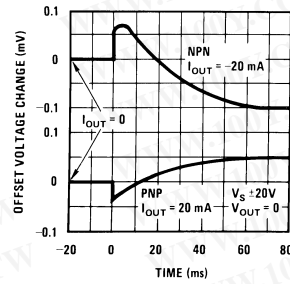

DS005652-40

**Thermal Gradient Cross-coupling**

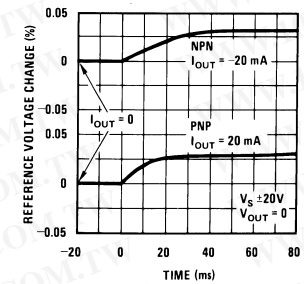

DS005652-41

**Shunt Gain**

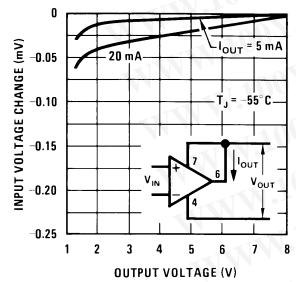

DS005652-42

**Shunt Gain**

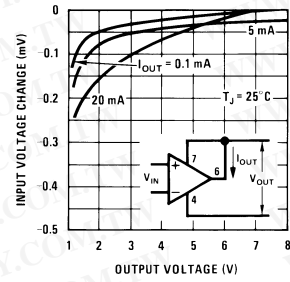

DS005652-43

**Shunt Gain**

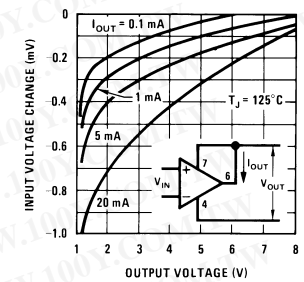

DS005652-44

## Typical Performance Characteristics (Reference)

Line Regulation

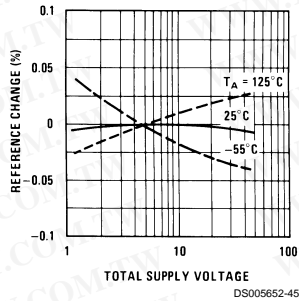

Load Regulation

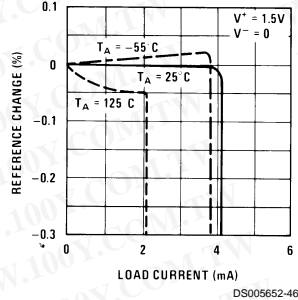

Reference Noise Voltage

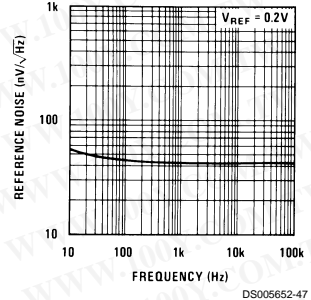

Minimum Supply Voltage

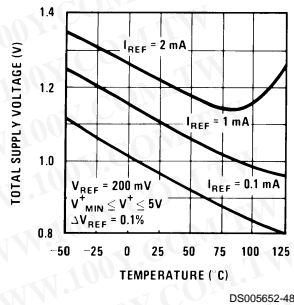

Output Saturation

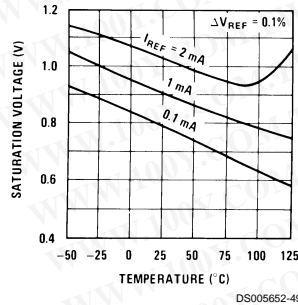

Typical Stability Range

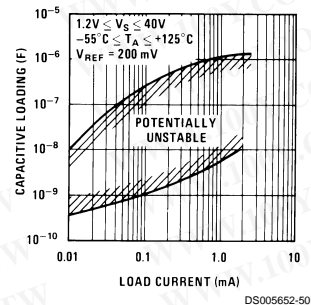

## Typical Applications (Note 10) (Pin numbers are for devices in 8-pin packages)

Op Amp Offset Adjustment

Standard

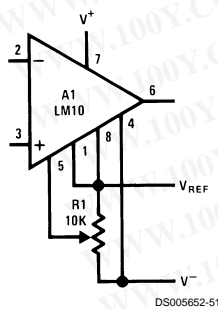

Limited Range

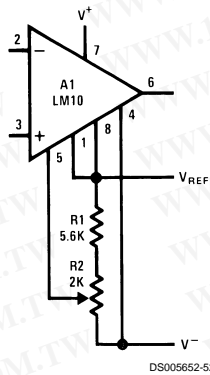

Limited Range With Boosted Reference

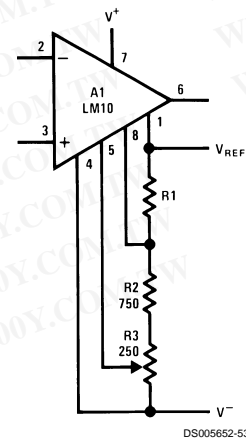



**Typical Applications** (Note 10) (Pin numbers are for devices in 8-pin packages) (Continued)

**Positive Regulators** (Note 9)

**Low Voltage**

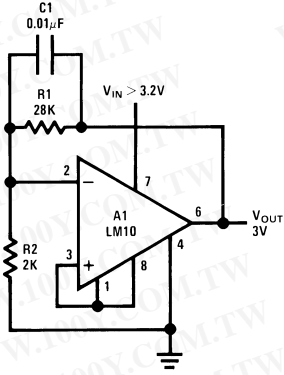

DS005652-54

**Best Regulation**

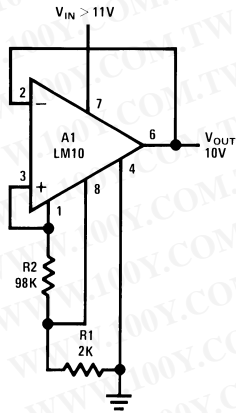

DS005652-55

**Zero Output**

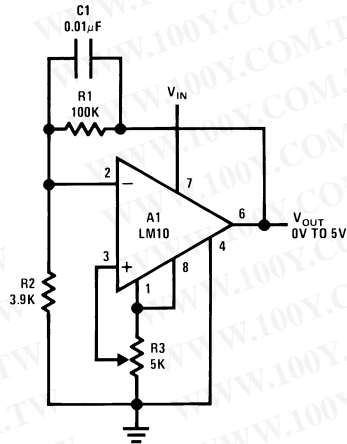

DS005652-56

**Note 9:** Use only electrolytic output capacitors.

**Current Regulator**

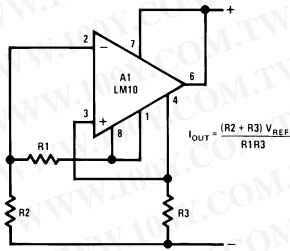

DS005652-57

**Shunt Regulator**

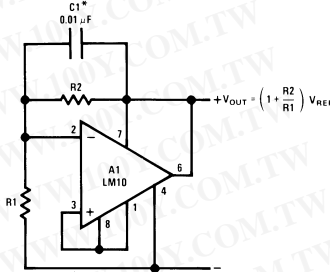

DS005652-58

Required For Capacitive Loading

**Negative Regulator**

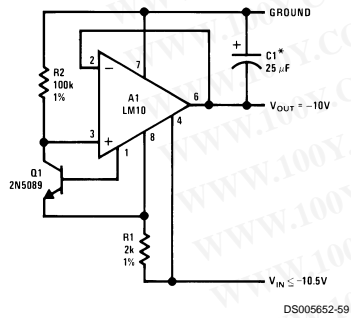

DS005652-59

\*Electrolytic

**Precision Regulator**

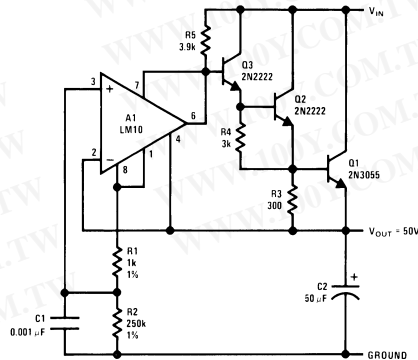

DS005652-60

**Typical Applications** (Note 10) (Pin numbers are for devices in 8-pin packages) (Continued)

**Laboratory Power Supply**

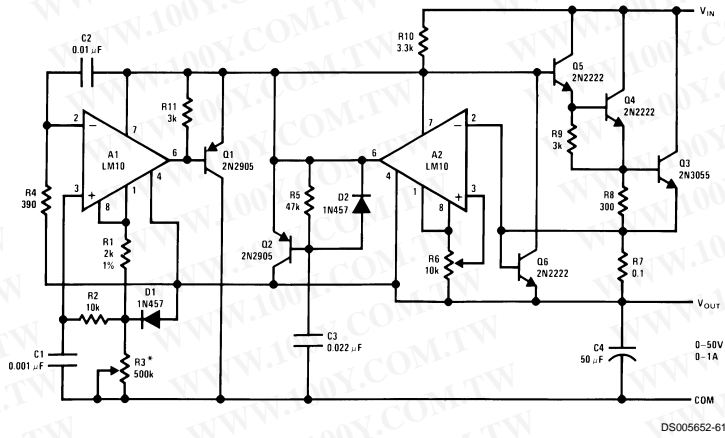

$V_{OUT} = 10^{-4} R_3$

**HV Regulator**

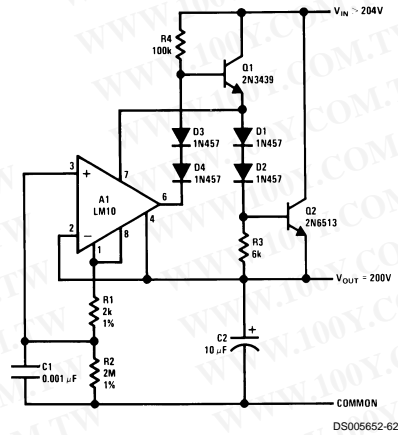

$V_{OUT} = \frac{R_2}{R_1} V_{REF}$   
DS005652-64

**Typical Applications** (Note 10) (Pin numbers are for devices in 8-pin packages) (Continued)

**Protected HV Regulator**

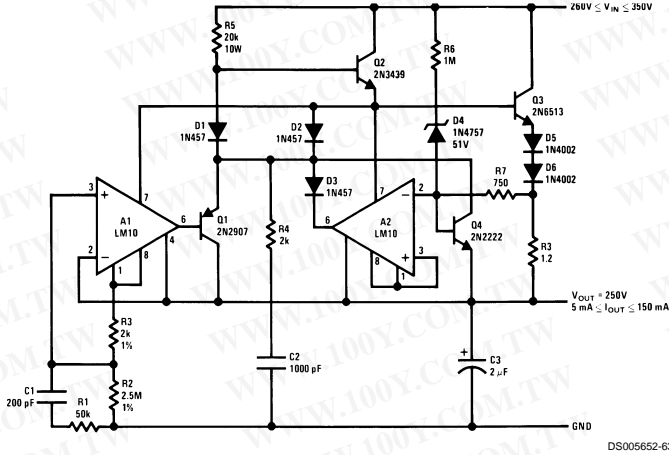

**Flame Detector**

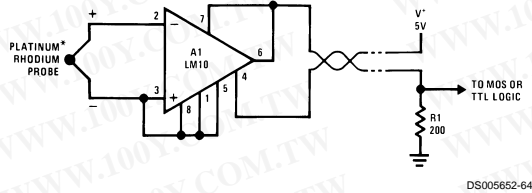

\*800°C Threshold Is Established By Connecting Balance To  $V_{REF}$ .

**Light Level Sensor**

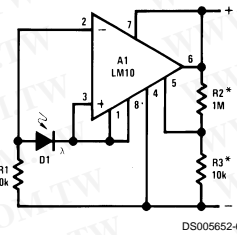

\*Provides Hysteresis

**Remote Amplifier**

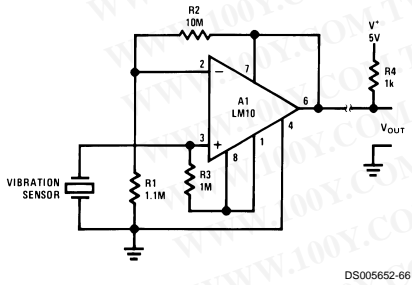

**Remote Thermocouple Amplifier**

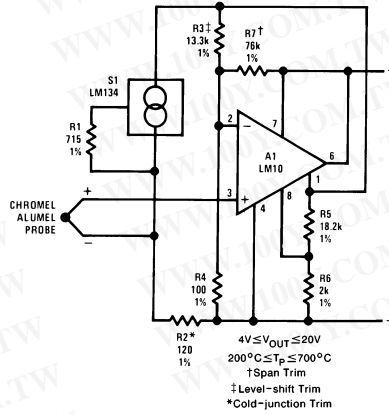

**Typical Applications** (Note 10) (Pin numbers are for devices in 8-pin packages) (Continued)

**Transmitter for Bridge Sensor**

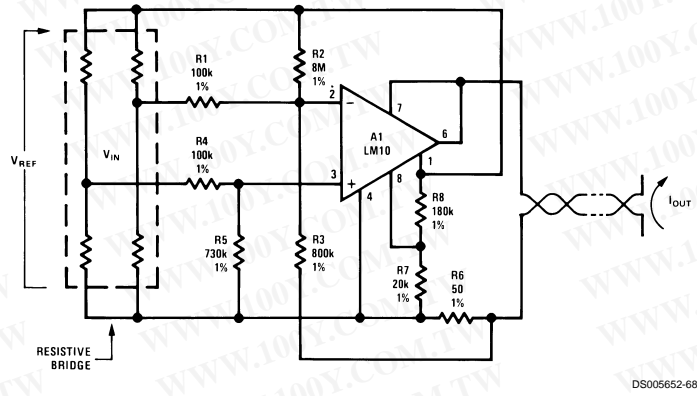

**Precision Thermocouple Transmitter**

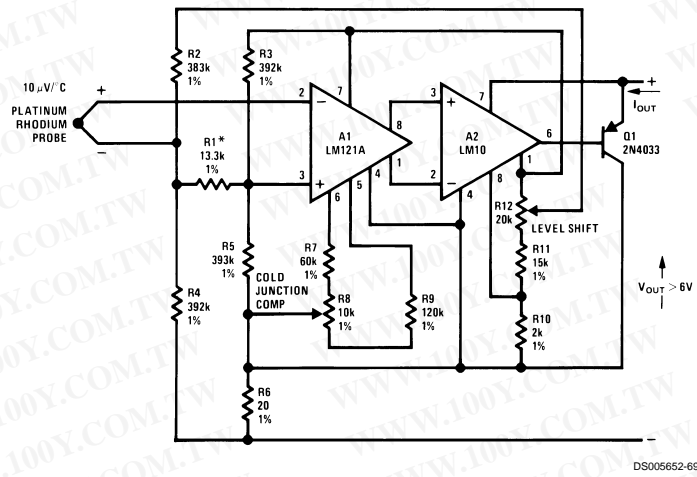

$10 \text{ mA} \leq I_{OUT} \leq 50 \text{ mA}$   
 $500^\circ \text{C} \leq T_P \leq 1500^\circ \text{C}$   
 \*Gain Trim

**Typical Applications** (Note 10) (Pin numbers are for devices in 8-pin packages) (Continued)

**Resistance Thermometer Transmitter**

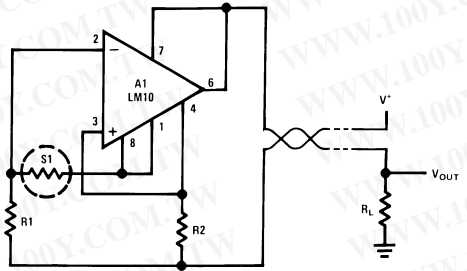

DS005652-70

**Optical Pyrometer**

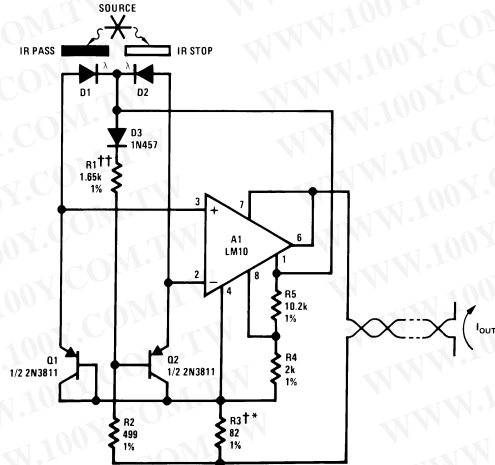

DS005652-71

††Level-shift Trim  
 \*Scale Factor Trim  
 †Copper Wire Wound

$1 \text{ mA} \leq I_{OUT} \leq 5 \text{ mA}$   
 $0.01 \leq \frac{I_{D2}}{I_{D1}} \leq 100$

**Thermocouple Transmitter**

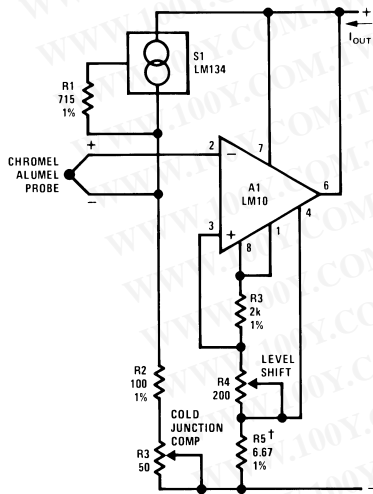

DS005652-72

$200^{\circ}\text{C} \leq T_p \leq 700^{\circ}\text{C}$   
 $1 \text{ mA} \leq I_{OUT} \leq 5 \text{ mA}$   
 †Gain Trim

**Logarithmic Light Sensor**

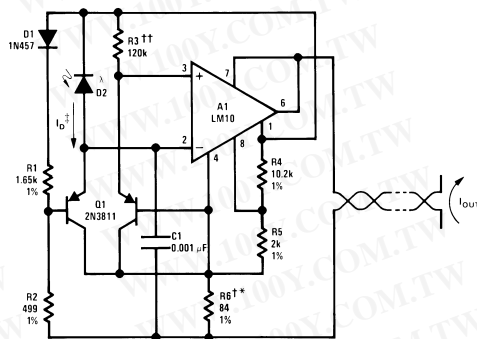

DS005652-73

$1 \text{ mA} \leq I_{OUT} \leq 5 \text{ mA}$   
 $150 \mu\text{A} \leq I_D \leq 500 \mu\text{A}$   
 ††Center Scale Trim  
 †Scale Factor Trim  
 \*Copper Wire Wound

**Typical Applications** (Note 10) (Pin numbers are for devices in 8-pin packages) (Continued)

**Battery-level Indicator**

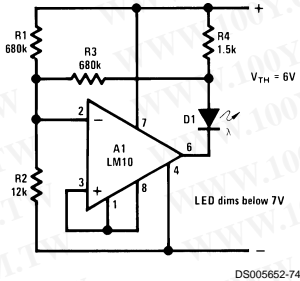

DS005652-74

**Battery-threshold Indicator**

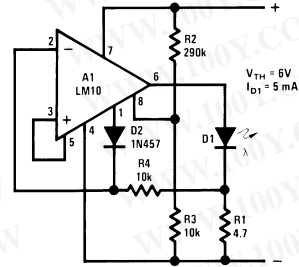

DS005652-75

**Single-cell Voltage Monitor**

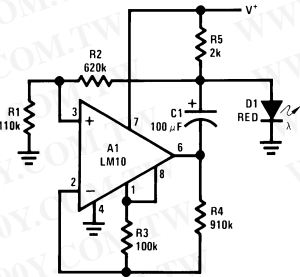

DS005652-76

Flashes Above 1.2V  
Rate Increases With  
Voltage

**Double-ended Voltage Monitor**

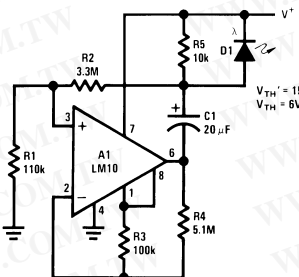

DS005652-77

Flash Rate Increases  
Above 6V and Below 15V

**Meter Amplifier**

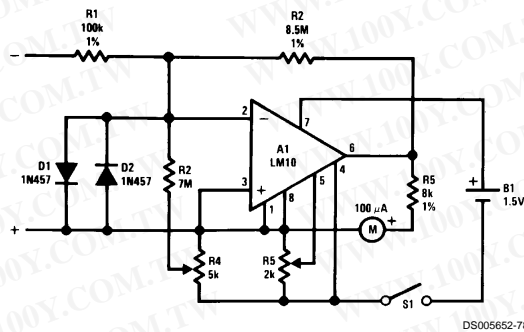

DS005652-78

INPUT  
10 mV, 100nA  
FULL-SCALE

**Typical Applications** (Note 10) (Pin numbers are for devices in 8-pin packages) (Continued)

**Thermometer**

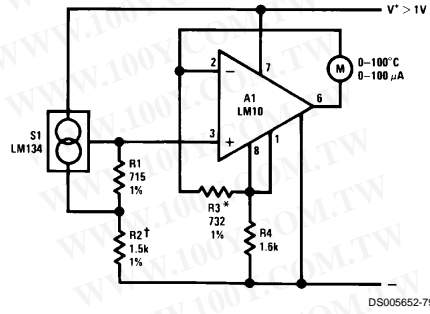

\*Trim For Span  
†Trim For Zero

DS005652-79

**Light Meter**

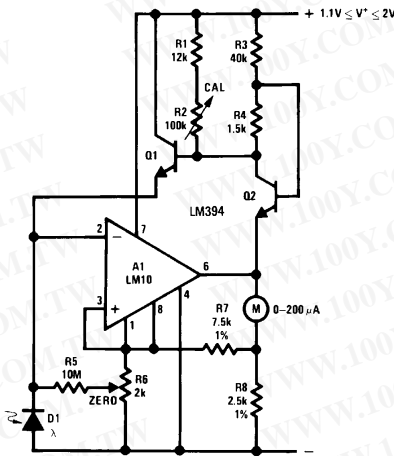

$1 \leq \lambda/\lambda_0 \leq 10^5$

DS005652-80

**Typical Applications** (Note 10) (Pin numbers are for devices in 8-pin packages) (Continued)

**Microphone Amplifier**

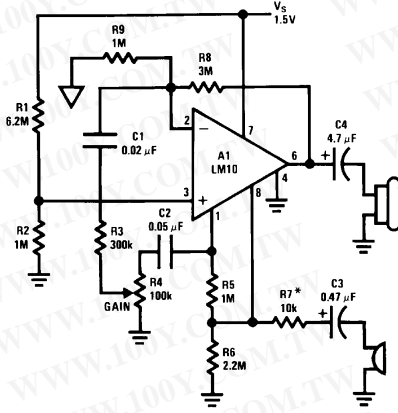

DS005652-81

$Z_{OUT} \sim 680\Omega @ 5\text{ kHz}$   
 $A_V \leq 1k$   
 $f_1 \sim 100\text{ Hz}$   
 $f_2 \sim 5\text{ kHz}$   
 $R_L \sim 500$   
 \*Max Gain Trim

**Isolated Voltage Sensor**

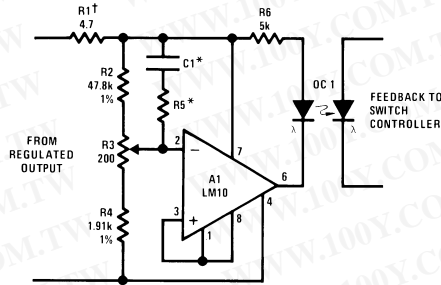

DS005652-82

†Controls "Loop Gain"  
 \*Optional Frequency Shaping



**Typical Applications** (Note 10) (Pin numbers are for devices in 8-pin packages) (Continued)

**Light-level Controller**

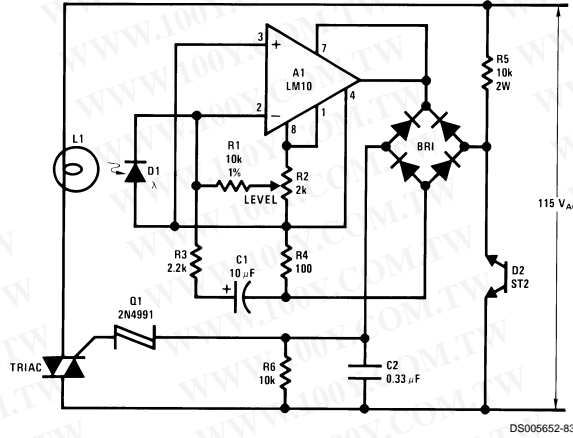

**Note 10:** Circuit descriptions available in application note AN-211.

**Application Hints**

With heavy amplifier loading to  $V^-$ , resistance drops in the  $V^-$  lead can adversely affect reference regulation. Lead resistance can approach  $1\Omega$ . Therefore, the common to the reference circuitry should be connected as close as possible to the package.

勝特力材料 886-3-5753170  
勝特力电子(上海) 86-21-54151736  
勝特力电子(深圳) 86-755-83298787  
[Http://www.100y.com.tw](http://www.100y.com.tw)

**Operational Amplifier Schematic** (Pin numbers are for 8-pin packages)

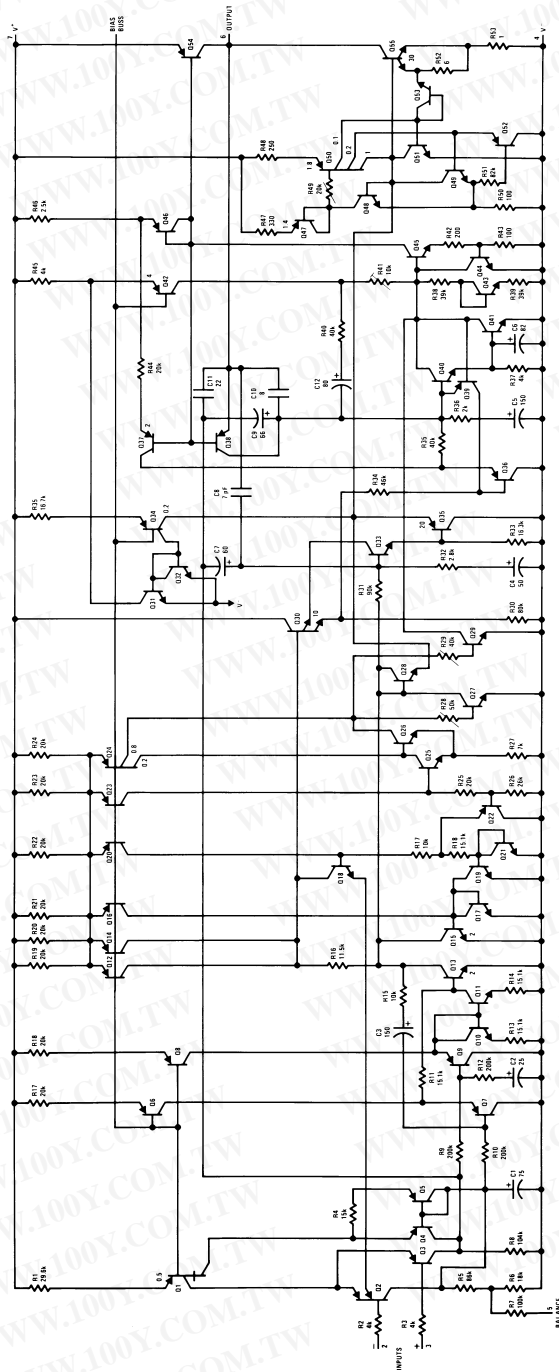

DS009652-13

**Reference and Internal Regulator** (Pin numbers are for 8-pin packages)

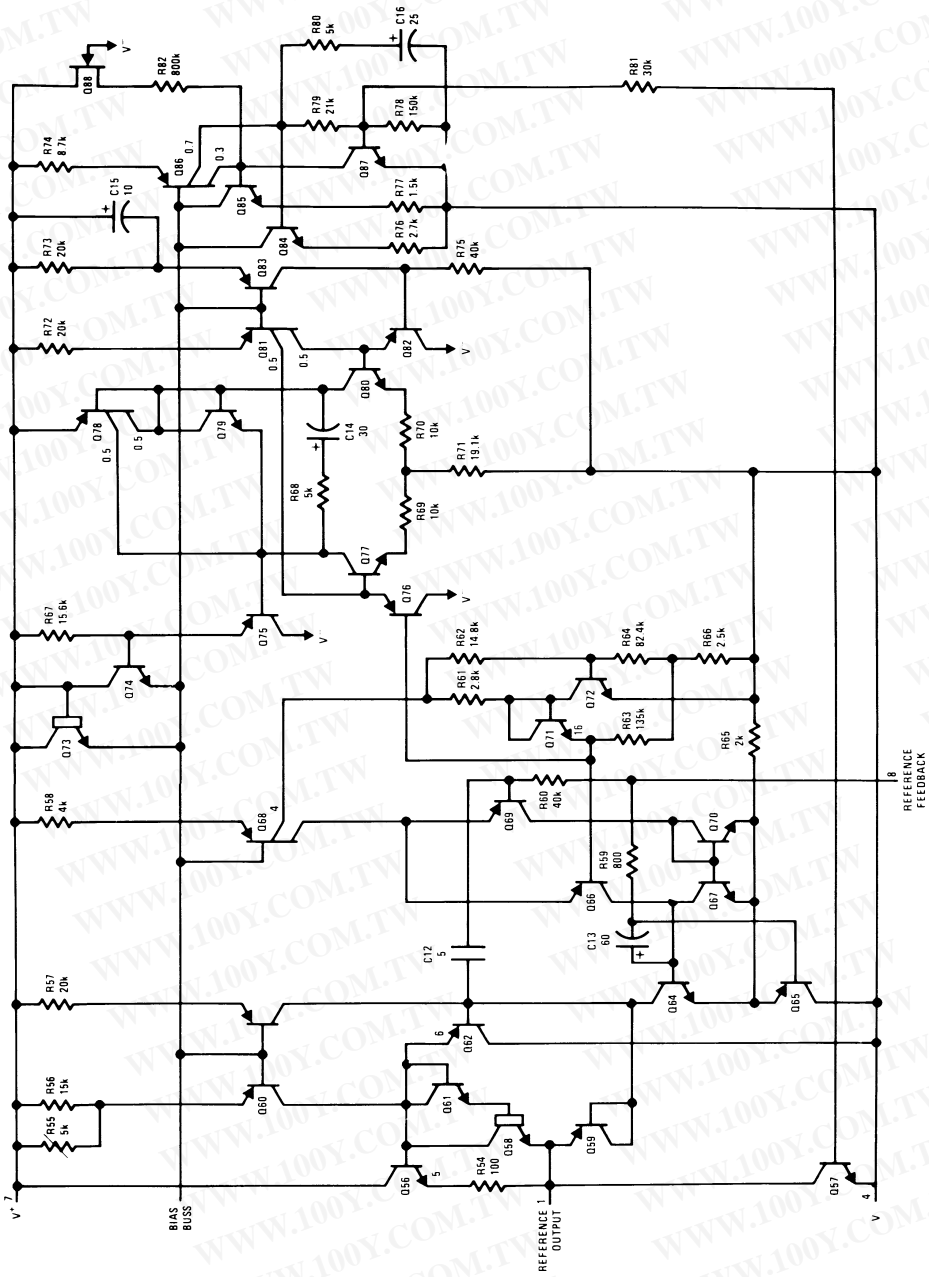

DS00652-14

**Physical Dimensions** inches (millimeters) unless otherwise noted

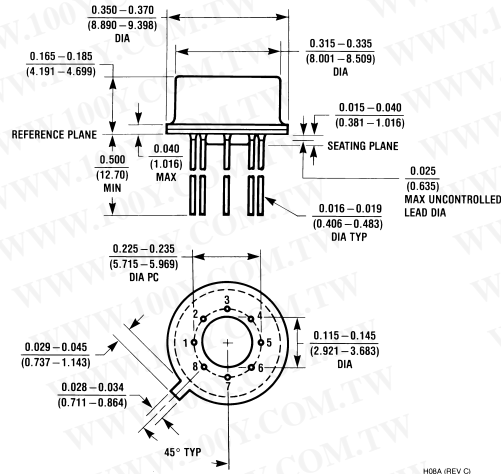

**Metal Can Package (H)**  
 Order Number LM10BH, LM10CH, LM10CLH or LM10H/883  
 NS Package Number H08A

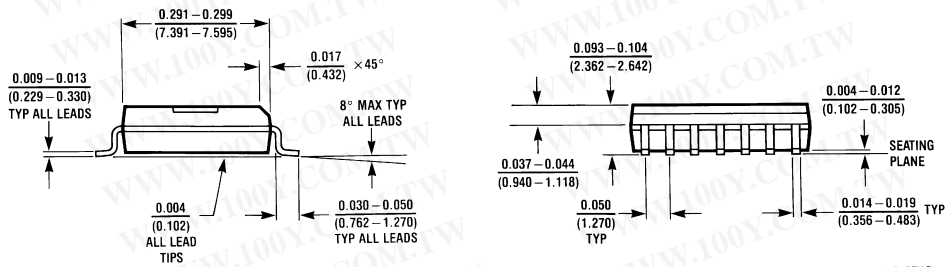
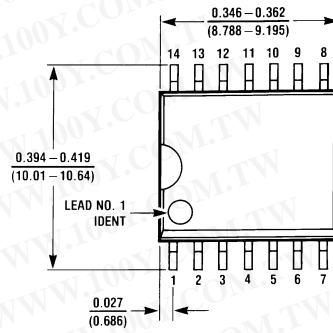

**S.O. Package (WM)**  
 Order Number LM10CWM  
 NS Package Number M14B

**Physical Dimensions** inches (millimeters) unless otherwise noted (Continued)

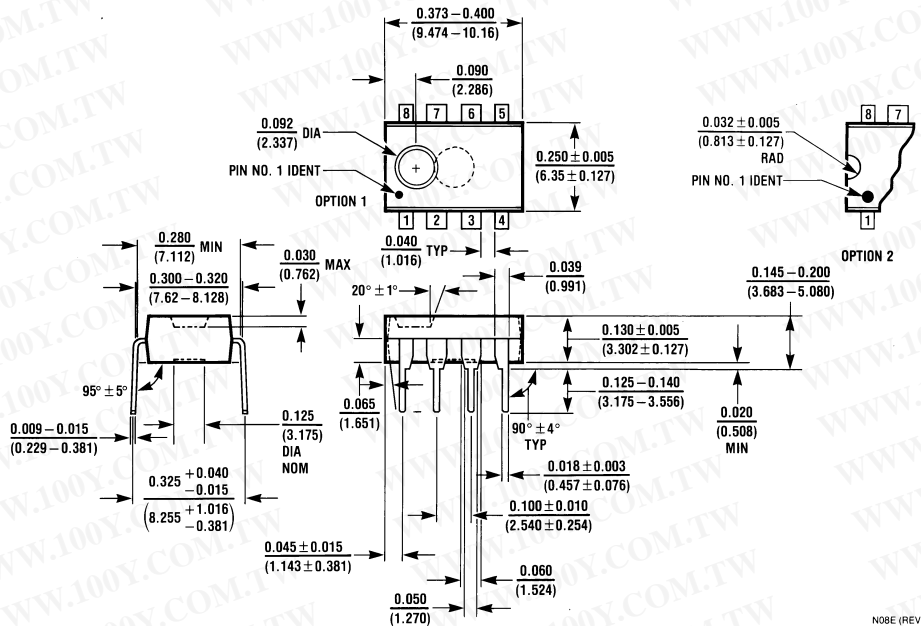

Dual-In-Line Package (N)  
 Order Number LM10CN or LM10CLN  
 NS Package Number N08E

NO8E (REV F)

**LIFE SUPPORT POLICY**

NATIONAL'S PRODUCTS ARE NOT AUTHORIZED FOR USE AS CRITICAL COMPONENTS IN LIFE SUPPORT DEVICES OR SYSTEMS WITHOUT THE EXPRESS WRITTEN APPROVAL OF THE PRESIDENT OF NATIONAL SEMICONDUCTOR CORPORATION. As used herein:

1. Life support devices or systems are devices or systems which, (a) are intended for surgical implant into the body, or (b) support or sustain life, and whose failure to perform when properly used in accordance with instructions for use provided in the labeling, can be reasonably expected to result in a significant injury to the user.
2. A critical component is any component of a life support device or system whose failure to perform can be reasonably expected to cause the failure of the life support device or system, or to affect its safety or effectiveness.

**National Semiconductor Corporation**  
 Americas  
 Tel: 1-800-272-9959  
 Fax: 1-800-737-7018  
 Email: support@nsc.com

**National Semiconductor Europe**  
 Fax: +49 (0) 1 80-530 85 86  
 Email: europe.support@nsc.com  
 Deutsch Tel: +49 (0) 1 80-530 85 85  
 English Tel: +49 (0) 1 80-532 78 32  
 Français Tel: +49 (0) 1 80-532 93 58  
 Italiano Tel: +49 (0) 1 80-534 16 80

**National Semiconductor Asia Pacific Customer Response Group**  
 Tel: 65-2544466  
 Fax: 65-2504466  
 Email: sea.support@nsc.com

**National Semiconductor Japan Ltd.**  
 Tel: 81-3-5639-7560  
 Fax: 81-3-5639-7507

www.national.com