

LM118/LM218/LM318 Operational Amplifiers

勝特力材料 886-3-5753170
 勝特力电子(上海) 86-21-54151736
 勝特力电子(深圳) 86-755-83298787
[Http://www.100y.com.tw](http://www.100y.com.tw)

General Description

The LM118 series are precision high speed operational amplifiers designed for applications requiring wide bandwidth and high slew rate. They feature a factor of ten increase in speed over general purpose devices without sacrificing DC performance.

The LM118 series has internal unity gain frequency compensation. This considerably simplifies its application since no external components are necessary for operation. However, unlike most internally compensated amplifiers, external frequency compensation may be added for optimum performance. For inverting applications, feedforward compensation will boost the slew rate to over 150V/μs and almost double the bandwidth. Overcompensation can be used with the amplifier for greater stability when maximum bandwidth is not needed. Further, a single capacitor can be added to reduce the 0.1% settling time to under 1 μs.

The high speed and fast settling time of these op amps make them useful in A/D converters, oscillators, active filters,

sample and hold circuits, or general purpose amplifiers. These devices are easy to apply and offer an order of magnitude better AC performance than industry standards such as the LM709.

The LM218 is identical to the LM118 except that the LM218 has its performance specified over a -25°C to +85°C temperature range. The LM318 is specified from 0°C to +70°C.

Features

- 15 MHz small signal bandwidth
- Guaranteed 50V/μs slew rate
- Maximum bias current of 250 nA
- Operates from supplies of ±5V to ±20V
- Internal frequency compensation
- Input and output overload protected
- Pin compatible with general purpose op amps

Fast Voltage Follower

(Note 1)

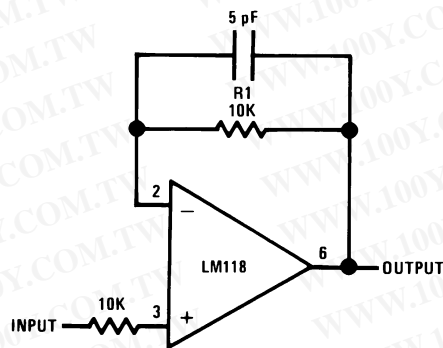

DS007766-13

Note 1: Do not hard-wire as voltage follower ($R1 \geq 5 \text{ k}\Omega$)

Absolute Maximum Ratings (Note 7)

If Military/Aerospace specified devices are required, please contact the National Semiconductor Sales Office/Distributors for availability and specifications.

Supply Voltage	±20V
Power Dissipation (Note 2)	500 mW
Differential Input Current (Note 3)	±10 mA
Input Voltage (Note 4)	±15V
Output Short-Circuit Duration	Continuous
Operating Temperature Range	
LM118	-55°C to +125°C
LM218	-25°C to +85°C
LM318	0°C to +70°C
Storage Temperature Range	-65°C to +150°C

Lead Temperature (Soldering, 10 sec.)	
Hermetic Package	300°C
Plastic Package	260°C
Soldering Information	
Dual-In-Line Package	
Soldering (10 sec.)	260°C
Small Outline Package	
Vapor Phase (60 sec.)	215°C
Infrared (15 sec.)	220°C
See AN-450 "Surface Mounting Methods and Their Effect on Product Reliability" for other methods of soldering surface mount devices.	
ESD Tolerance (Note 8)	2000V

Electrical Characteristics (Note 5)

Parameter	Conditions	LM118/LM218			LM318			Units
		Min	Typ	Max	Min	Typ	Max	
Input Offset Voltage	$T_A = 25^\circ\text{C}$		2	4		4	10	mV
Input Offset Current	$T_A = 25^\circ\text{C}$		6	50		30	200	nA
Input Bias Current	$T_A = 25^\circ\text{C}$		120	250		150	500	nA
Input Resistance	$T_A = 25^\circ\text{C}$	1	3		0.5	3		MΩ
Supply Current	$T_A = 25^\circ\text{C}$		5	8		5	10	mA
Large Signal Voltage Gain	$T_A = 25^\circ\text{C}$, $V_S = \pm 15\text{V}$ $V_{OUT} = \pm 10\text{V}$, $R_L \geq 2\text{ k}\Omega$	50	200		25	200		V/mV
Slew Rate	$T_A = 25^\circ\text{C}$, $V_S = \pm 15\text{V}$, $A_V = 1$ (Note 6)	50	70		50	70		V/μs
Small Signal Bandwidth	$T_A = 25^\circ\text{C}$, $V_S = \pm 15\text{V}$		15			15		MHz
Input Offset Voltage				6			15	mV
Input Offset Current				100			300	nA
Input Bias Current				500			750	nA
Supply Current	$T_A = 125^\circ\text{C}$		4.5	7				mA
Large Signal Voltage Gain	$V_S = \pm 15\text{V}$, $V_{OUT} = \pm 10\text{V}$ $R_L \geq 2\text{ k}\Omega$	25			20			V/mV
Output Voltage Swing	$V_S = \pm 15\text{V}$, $R_L = 2\text{ k}\Omega$	±12	±13		±12	±13		V
Input Voltage Range	$V_S = \pm 15\text{V}$	±11.5			±11.5			V
Common-Mode Rejection Ratio		80	100		70	100		dB
Supply Voltage Rejection Ratio		70	80		65	80		dB

Note 2: The maximum junction temperature of the LM118 is 150°C, the LM218 is 110°C, and the LM318 is 110°C. For operating at elevated temperatures, devices in the H08 package must be derated based on a thermal resistance of 160°C/W, junction to ambient, or 20°C/W, junction to case. The thermal resistance of the dual-in-line package is 100°C/W, junction to ambient.

Note 3: The inputs are shunted with back-to-back diodes for overvoltage protection. Therefore, excessive current will flow if a differential input voltage in excess of 1V is applied between the inputs unless some limiting resistance is used.

Note 4: For supply voltages less than ±15V, the absolute maximum input voltage is equal to the supply voltage.

Note 5: These specifications apply for $\pm 5\text{V} \leq V_S \leq \pm 20\text{V}$ and $-55^\circ\text{C} \leq T_A \leq +125^\circ\text{C}$ (LM118), $-25^\circ\text{C} \leq T_A \leq +85^\circ\text{C}$ (LM218), and $0^\circ\text{C} \leq T_A \leq +70^\circ\text{C}$ (LM318). Also, power supplies must be bypassed with 0.1 μF disc capacitors.

Note 6: Slew rate is tested with $V_S = \pm 15\text{V}$. The LM118 is in a unity-gain non-inverting configuration. V_{IN} is stepped from -7.5V to +7.5V and vice versa. The slew rates between -5.0V and +5.0V and vice versa are tested and guaranteed to exceed 50V/μs.

Note 7: Refer to RETS118X for LM118H and LM118J military specifications.

Note 8: Human body model, 1.5 kΩ in series with 100 pF.

勝特力材料 886-3-5753170
勝特力电子(上海) 86-21-54151736
勝特力电子(深圳) 86-755-83298787
[Http://www.100y.com.tw](http://www.100y.com.tw)

Typical Performance Characteristics LM118, LM218

Input Current

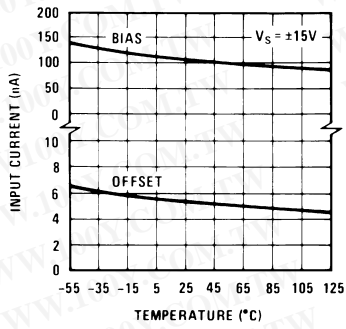

Voltage Gain

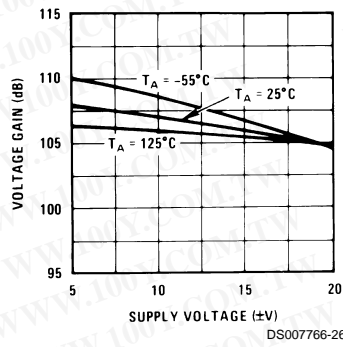

Power Supply Rejection

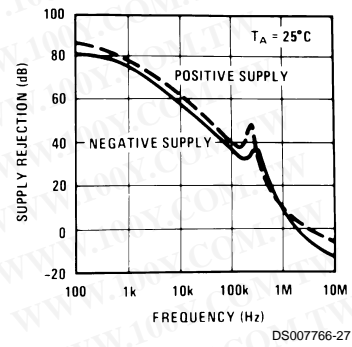

Input Noise Voltage

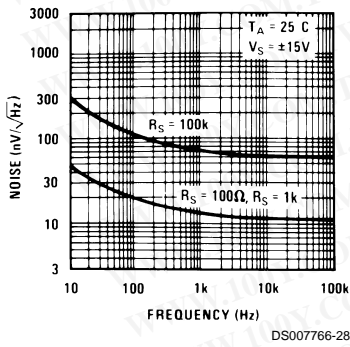

Common Mode Rejection

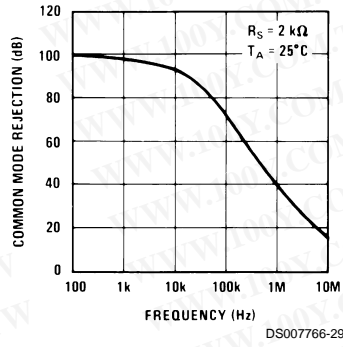

Supply Current

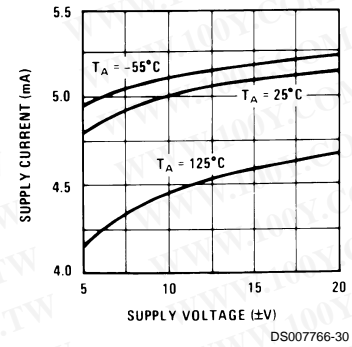

Closed Loop Output Impedance

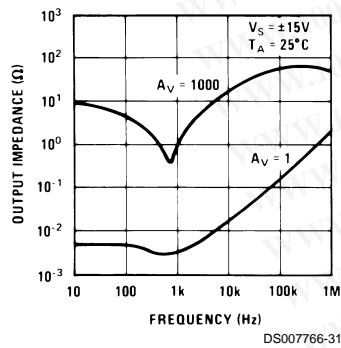

Current Limiting

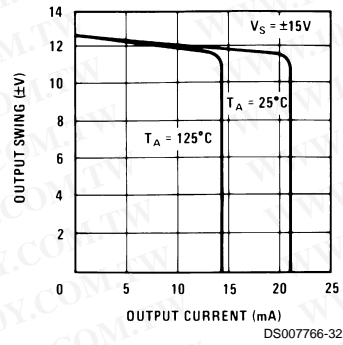

Input Current

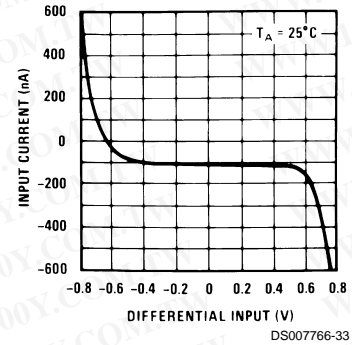

Unity Gain Bandwidth

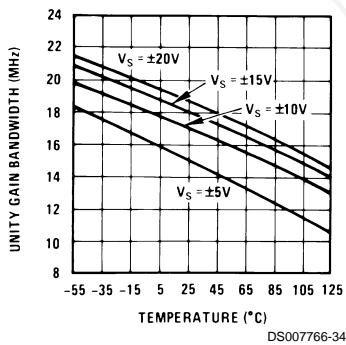

Voltage Follower Slew Rate

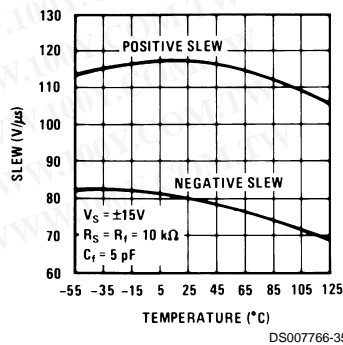

Inverter Settling Time

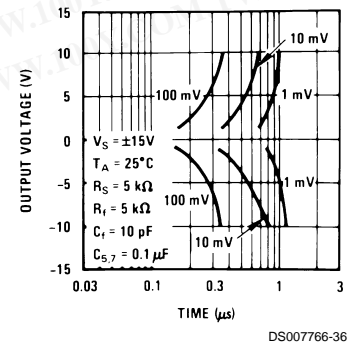

勝特力材料 886-3-5753170
 勝特力电子(上海) 86-21-54151736
 勝特力电子(深圳) 86-755-83298787
[Http://www.100y.com.tw](http://www.100y.com.tw)

Typical Performance Characteristics LM118, LM218 (Continued)

Large Signal Frequency Response

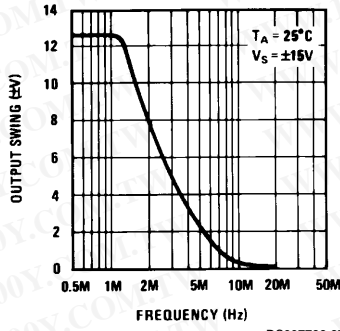

Open Loop Frequency Response

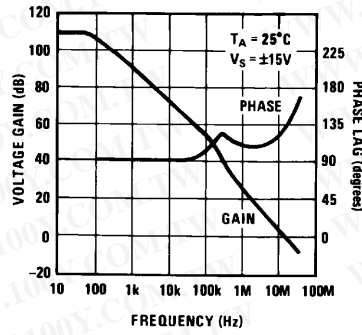

Voltage Follower Pulse Response

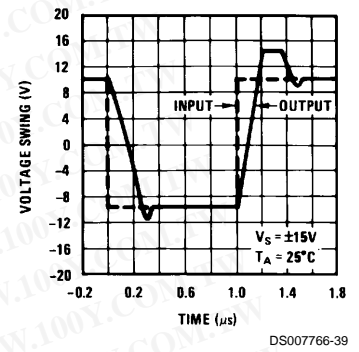

Large Signal Frequency Response

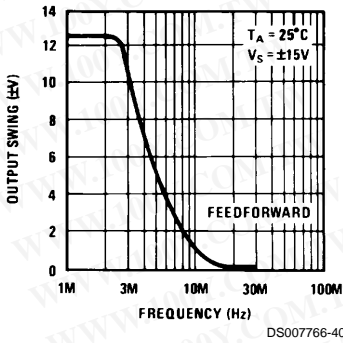

Open Loop Frequency Response

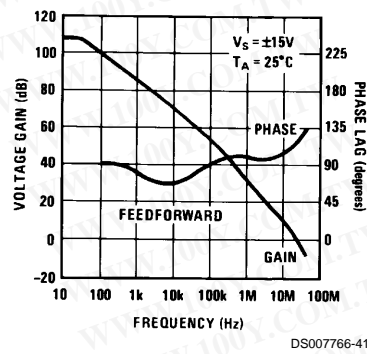

Inverter Pulse Response

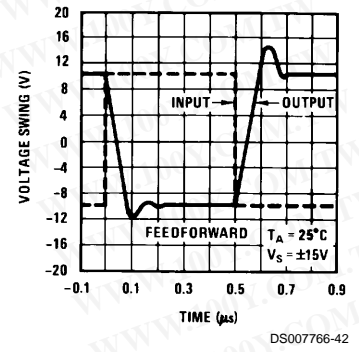

Typical Performance Characteristics LM318

Input Current

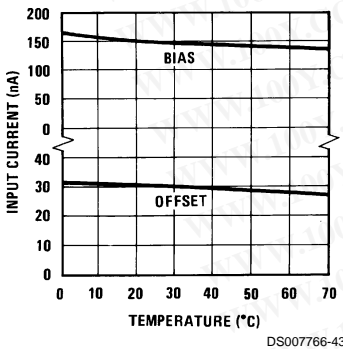

Voltage Gain

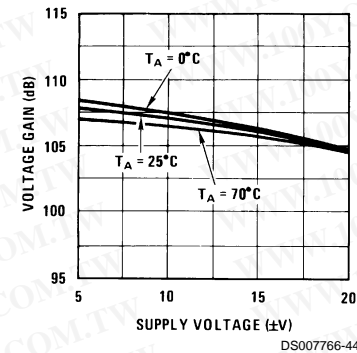

Power Supply Rejection

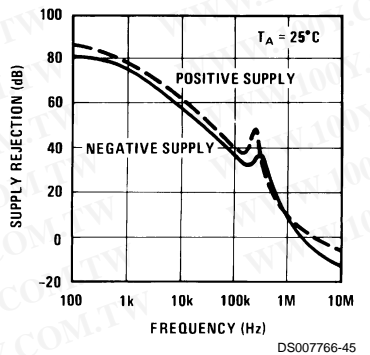

勝特力材料 886-3-5753170
 勝特力电子(上海) 86-21-54151736
 勝特力电子(深圳) 86-755-83298787
[Http://www.100y.com.tw](http://www.100y.com.tw)

Typical Performance Characteristics LM318 (Continued)

Input Noise Voltage

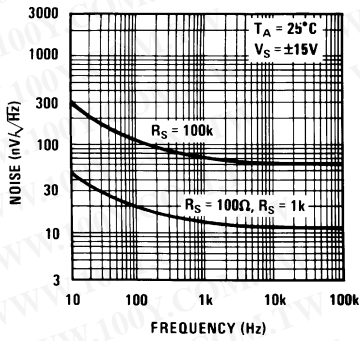

Common Mode Rejection

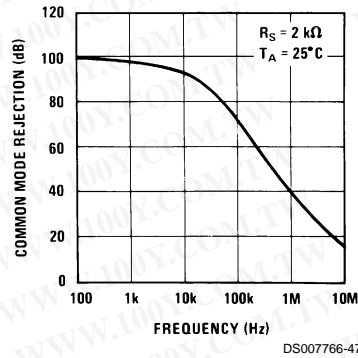

Supply Current

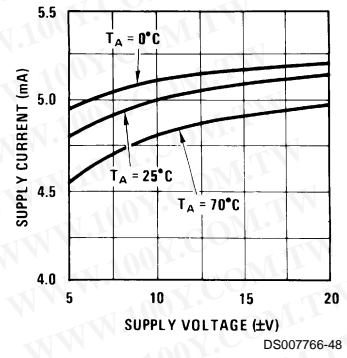

Closed Loop Output Impedance

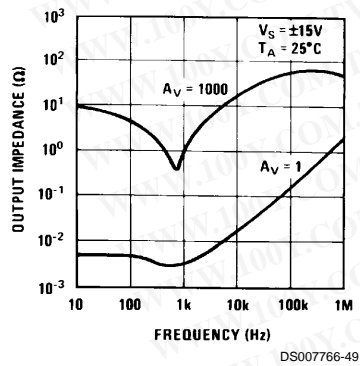

Current Limiting

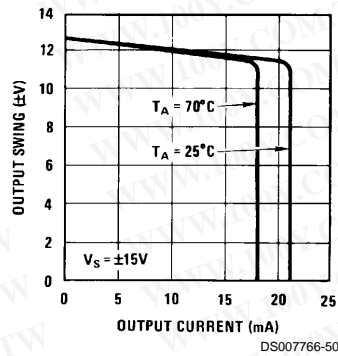

Input Current

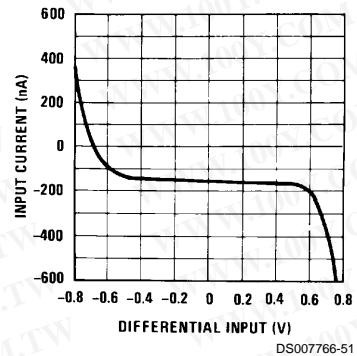

Unity Gain Bandwidth

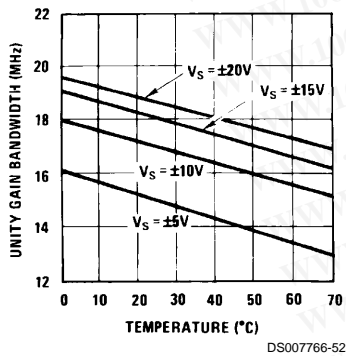

Voltage Follower Slew Rate

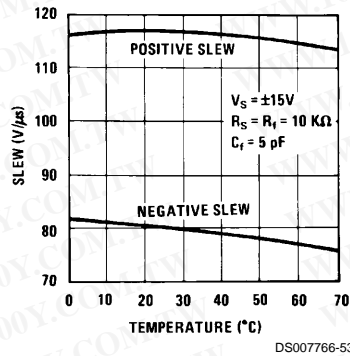

Inverter Settling Time

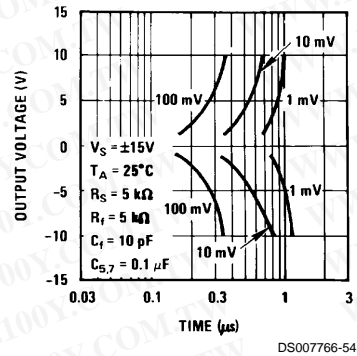

勝特力材料 886-3-5753170
 勝特力电子(上海) 86-21-54151736
 勝特力电子(深圳) 86-755-83298787
[Http://www.100y.com.tw](http://www.100y.com.tw)

Typical Performance Characteristics LM318 (Continued)

Large Signal Frequency Response

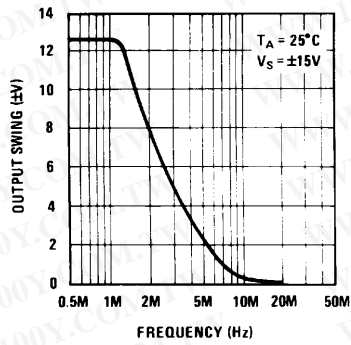

Open Loop Frequency Response

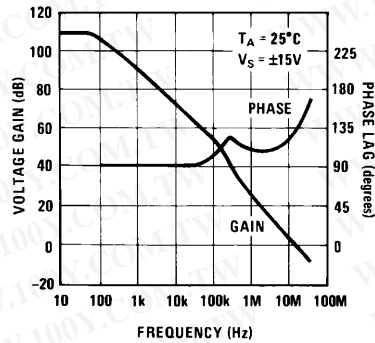

Voltage Follower Pulse Response

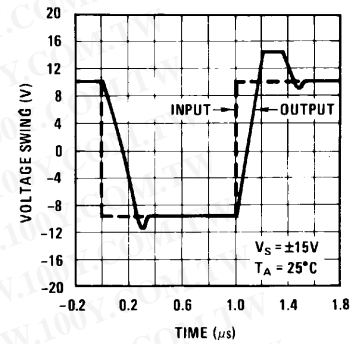

Large Signal Frequency Response

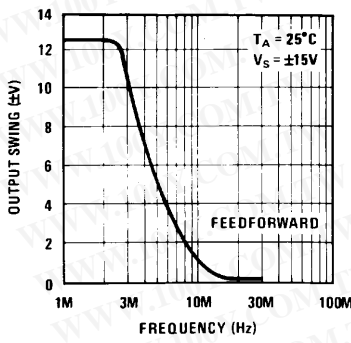

Open Loop Frequency Response

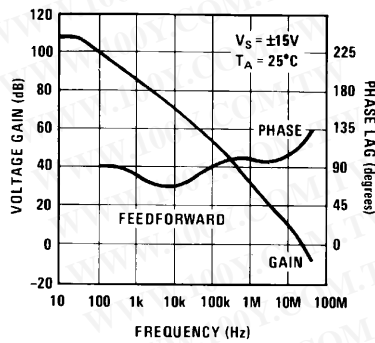

Inverter Pulse Response

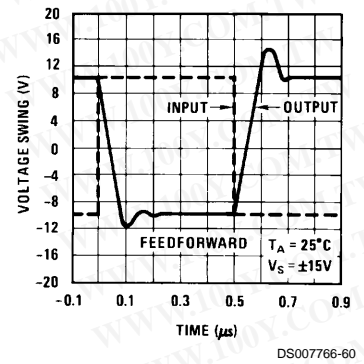

Auxiliary Circuits

Feedforward Compensation for Greater Inverting Slew Rate (Note 9)

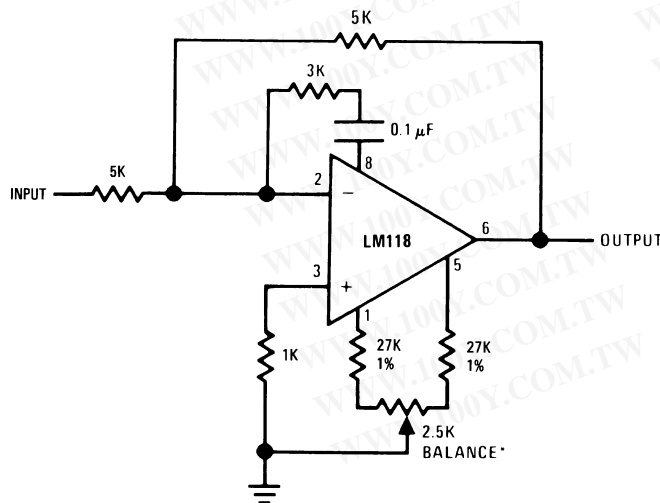

*Balance circuit necessary for increased slew.

Note 9: Slew rate typically 150V/µs.

Compensation for Minimum Settling Time (Note 10)

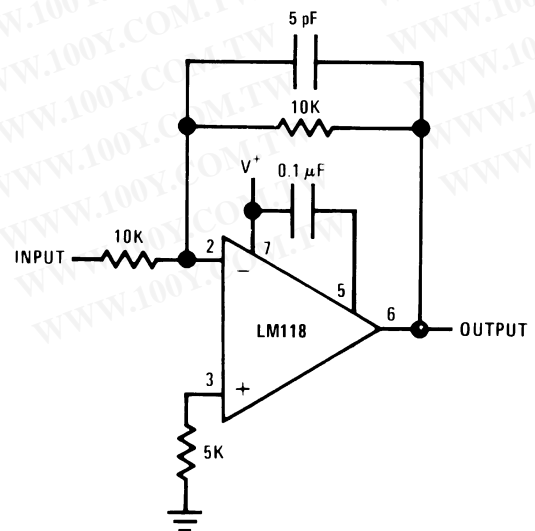

Note 10: Slew and settling time to 0.1% for a 10V step change is 800 ns.

Auxiliary Circuits (Continued)

Offset Balancing

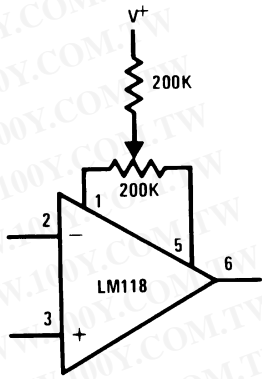

DS007766-10

Isolating Large Capacitive Loads

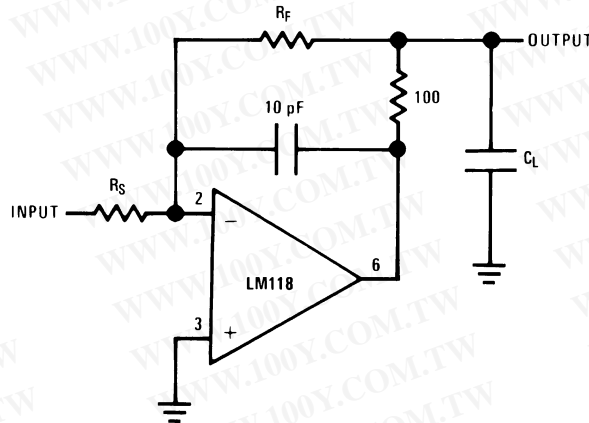

DS007766-11

Overcompensation

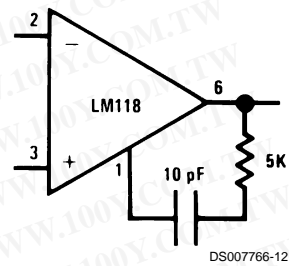

DS007766-12

勝特力材料 886-3-5753170
 勝特力电子(上海) 86-21-54151736
 勝特力电子(深圳) 86-755-83298787
[Http://www.100y.com.tw](http://www.100y.com.tw)

Typical Applications

Fast Voltage Follower (Note 11)

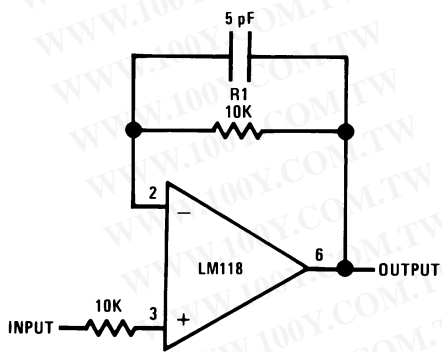

DS007766-13

Integrator or Slow Inverter

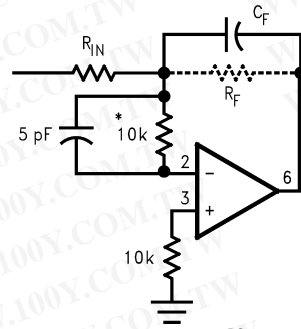

DS007766-14

$C_F = \text{Large}$
($C_F \geq 50 \text{ pF}$)

*Do not hard-wire as integrator or slow inverter; insert a 10k-5 pF network in series with the input, to prevent oscillation.

Note 11: Do not hard-wire as voltage follower ($R_1 \geq 5 \text{ k}\Omega$)

Fast Summing Amplifier

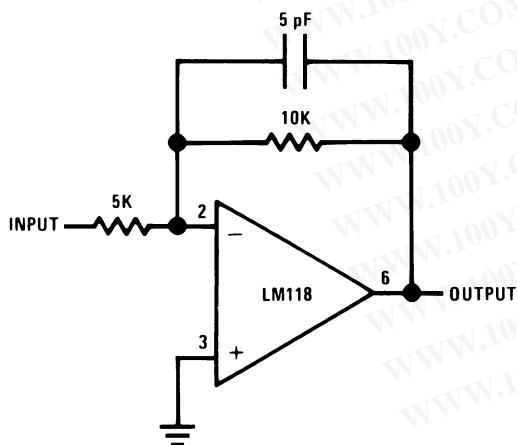

DS007766-15

Differential Amplifier

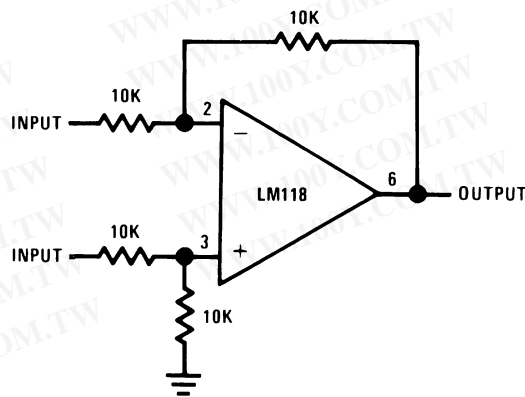

DS007766-16

Typical Applications (Continued)

勝特力材料 886-3-5753170
 勝特力电子(上海) 86-21-54151736
 勝特力电子(深圳) 86-755-83298787
[Http://www.100y.com.tw](http://www.100y.com.tw)

Fast Sample and Hold

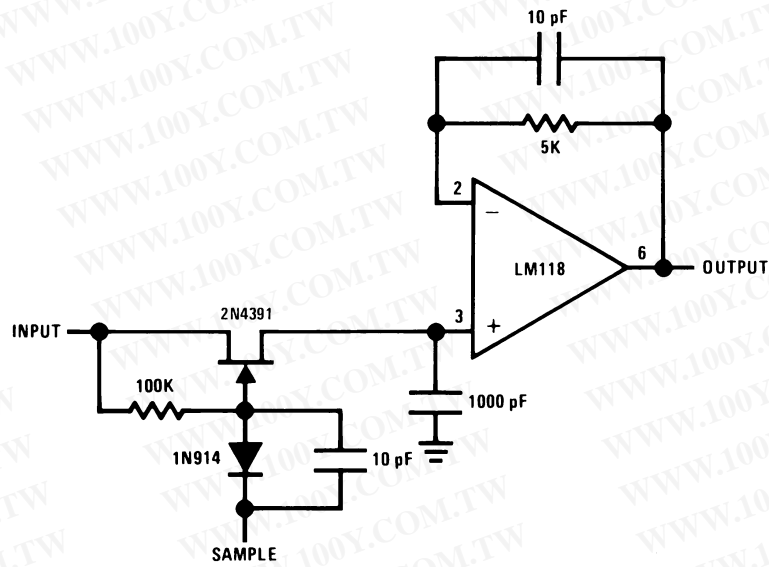

D/A Converter Using Ladder Network

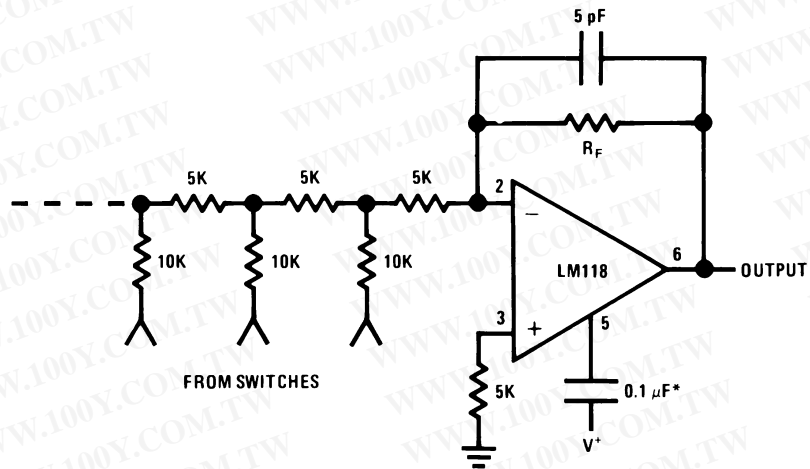

*Optional — Reduces settling time.

Typical Applications (Continued)

Four Quadrant Multiplier

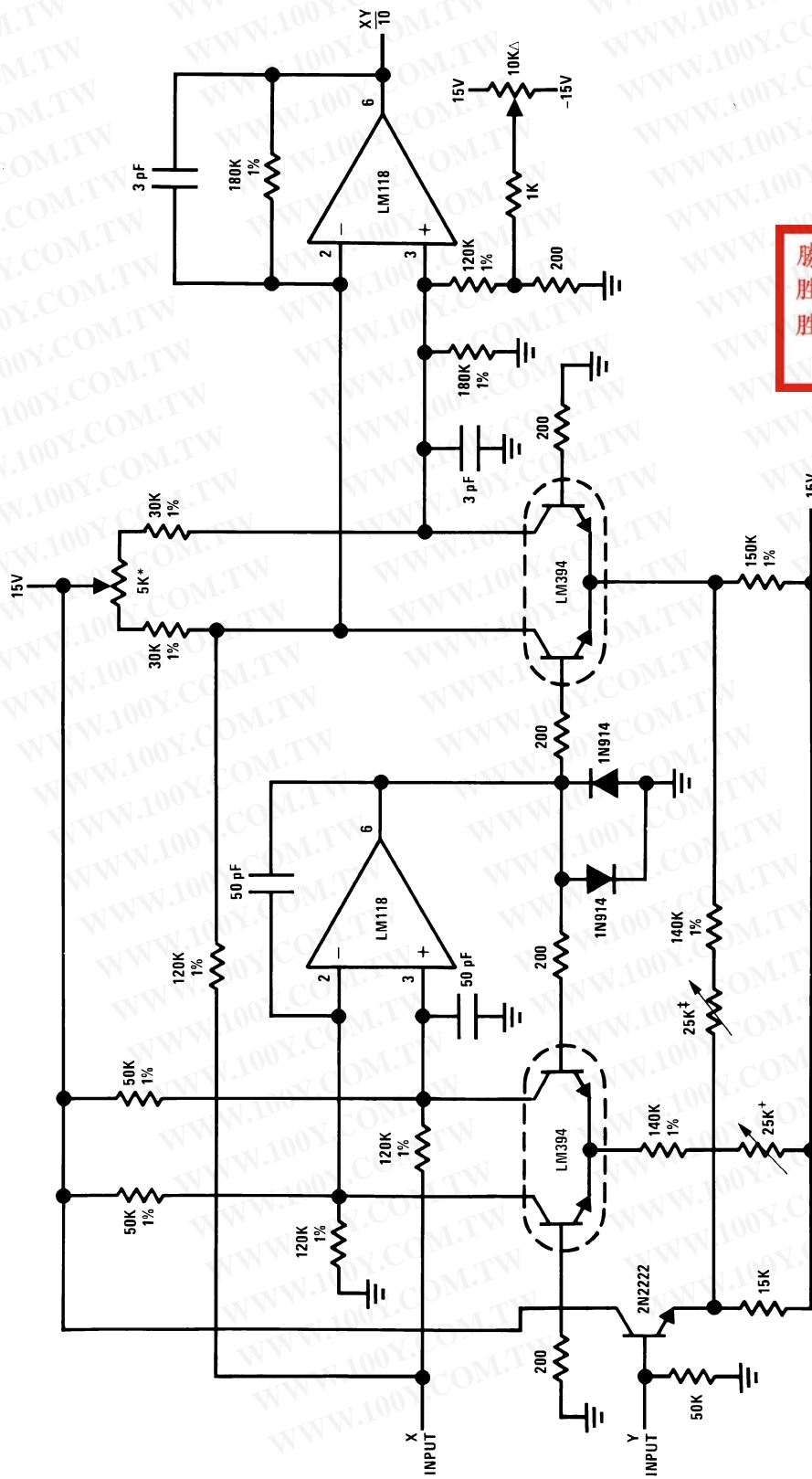

DS00766-17

勝特力材料 886-3-5753170
 勝特力电子(上海) 86-21-54151736
 勝特力电子(深圳) 86-755-83298787
[Http://www.100y.com.tw](http://www.100y.com.tw)

Δ Output zero.
 * "Y" zero
 + "X" zero
 ‡ Full scale adjust.

Typical Applications (Continued)

D/A Converter Using Binary Weighted Network

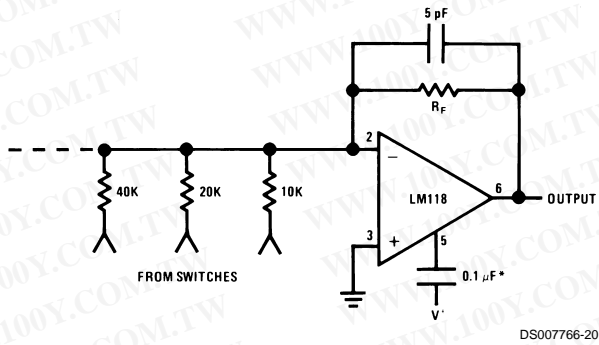

*Optional — Reduces settling time.

DS007766-20

Fast Summing Amplifier with Low Input Current

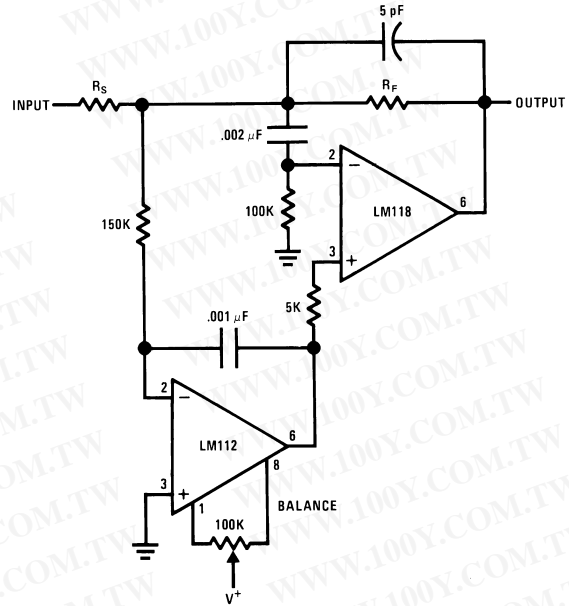

DS007766-21

Wein Bridge Sine Wave Oscillator

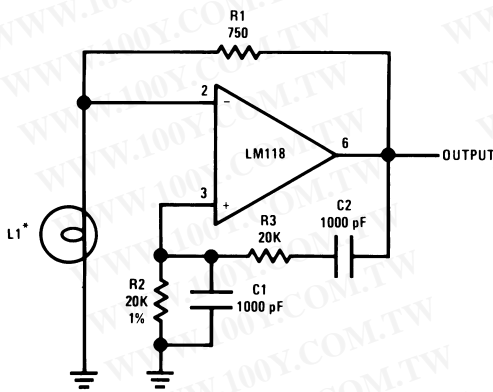

DS007766-22

*L1—10V—14 mA bulb ELDEMA 1869

R1 = R2

C1 = C2

$$f = \frac{1}{2\pi R_2 C_1}$$

Instrumentation Amplifier

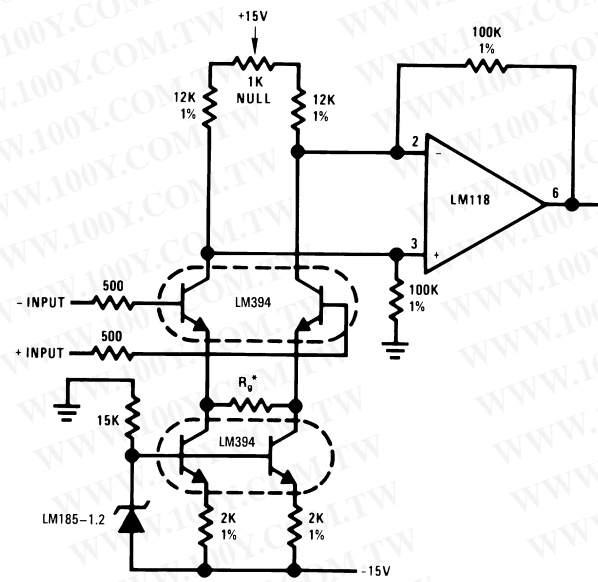

DS007766-23

$$*Gain \geq \frac{200K}{R_g} \text{ for } 1.5K \leq R_g \leq 200K$$

Schematic Diagram

勝特力材料 886-3-5753170
勝特力电子(上海) 86-21-54151736
勝特力电子(深圳) 86-755-83298787
[Http://www.100y.com.tw](http://www.100y.com.tw)

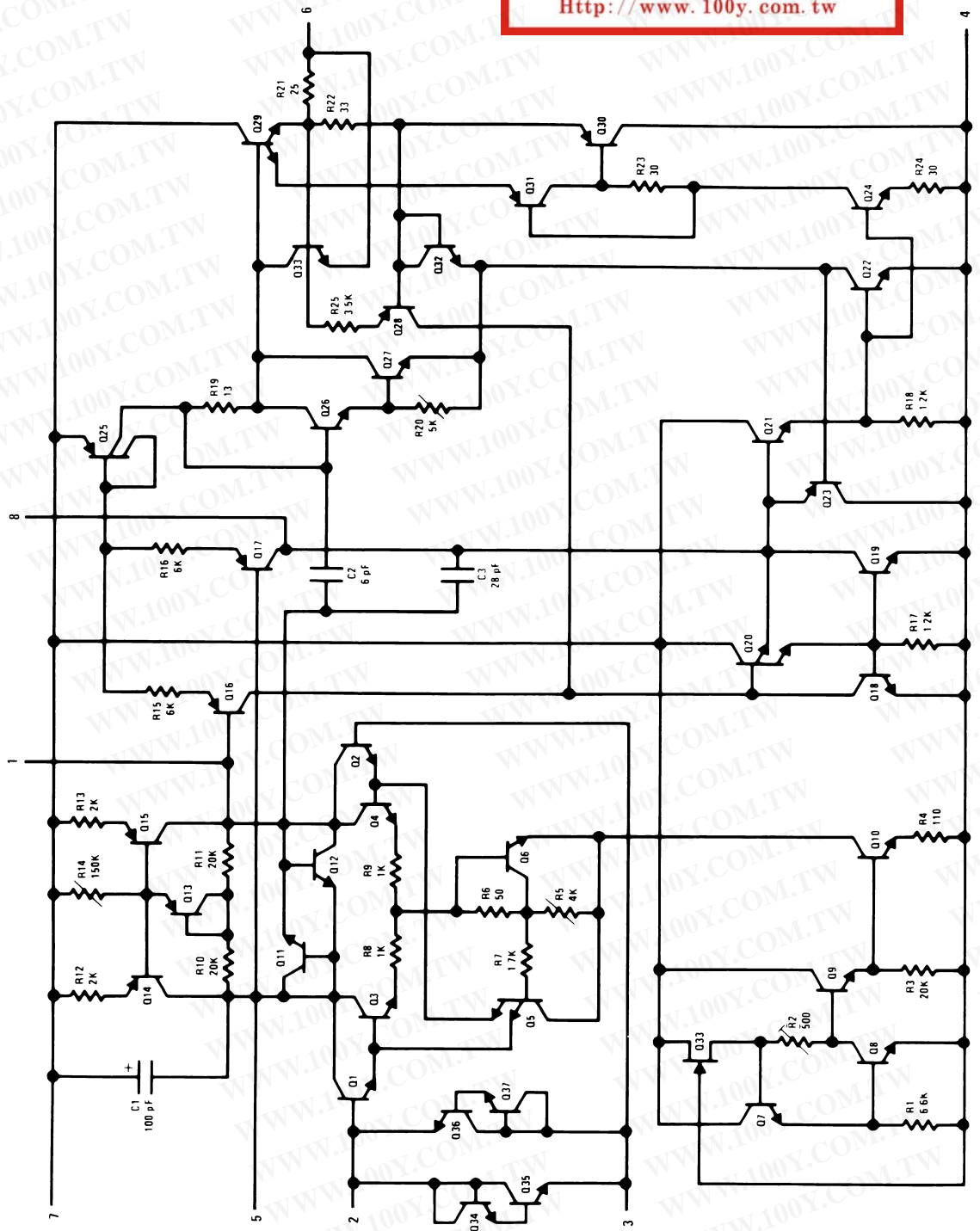

LM118/LM218/LM318

DS007766-1

勝特力材料 886-3-5753170
 勝特力电子(上海) 86-21-54151736
 勝特力电子(深圳) 86-755-83298787
[Http://www.100y.com.tw](http://www.100y.com.tw)

Connection Diagram

Dual-In-Line Package

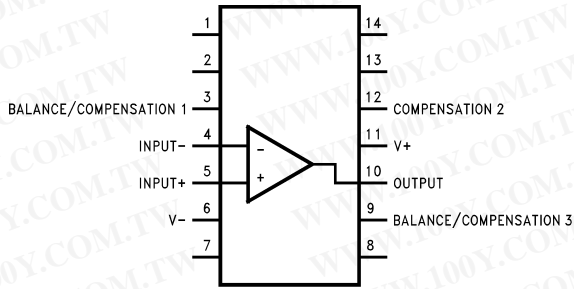

DS007766-24

Top View

Order Number LM118J/883 (Note 13)
 See NS Package Number J14A

Dual-In-Line Package

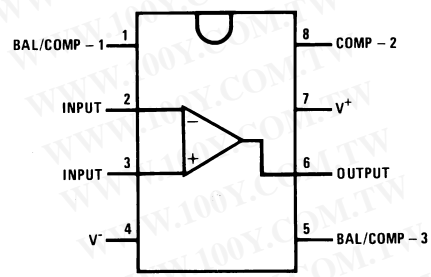

DS007766-3

Top View

Order Number LM118J-8/883 (Note 13),
 LM318M or LM318N
 See NS Package Number J08A, M08A or N08B

Metal Can Package
 (Note 12)

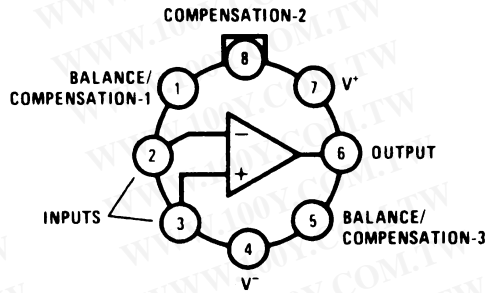

DS007766-2

Top View

Order Number LM118H, LM118H/883 (Note 13),
 LM218H or LM318H
 See NS Package Number H08C

Note 12: Pin connections shown on schematic diagram and typical applications are for TO-5 package.

Note 13: Available per JM38510/10107.

Physical Dimensions inches (millimeters) unless otherwise noted

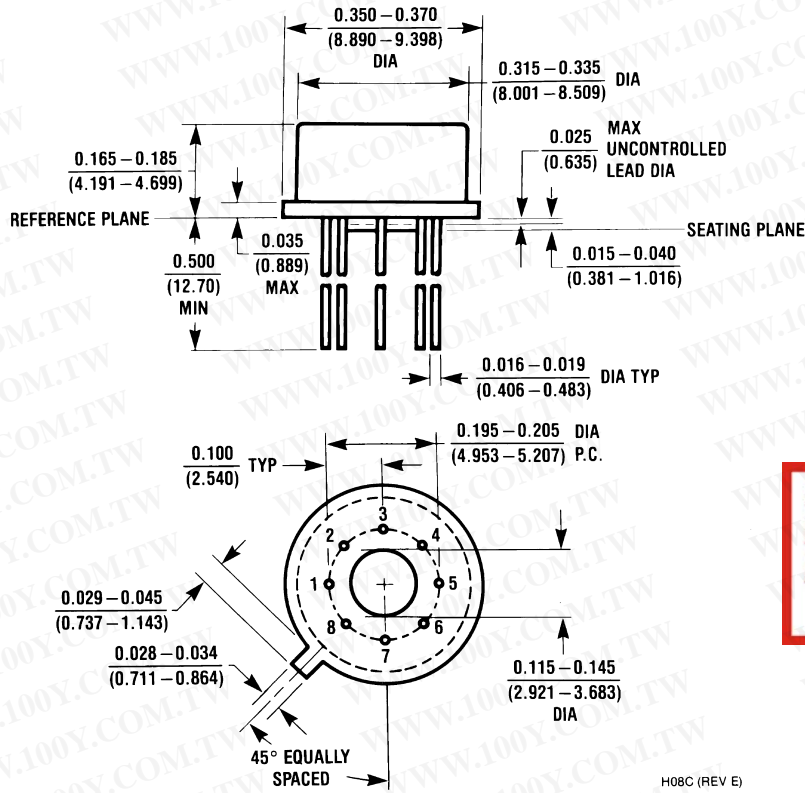

勝特力材料 886-3-5753170
 勝特力电子(上海) 86-21-54151736
 勝特力电子(深圳) 86-755-83298787
[Http://www.100y.com.tw](http://www.100y.com.tw)

Metal Can Package (H)
 Order Number LM118H, LM118H/883, LM218H or LM318H
 NS Package Number H08C

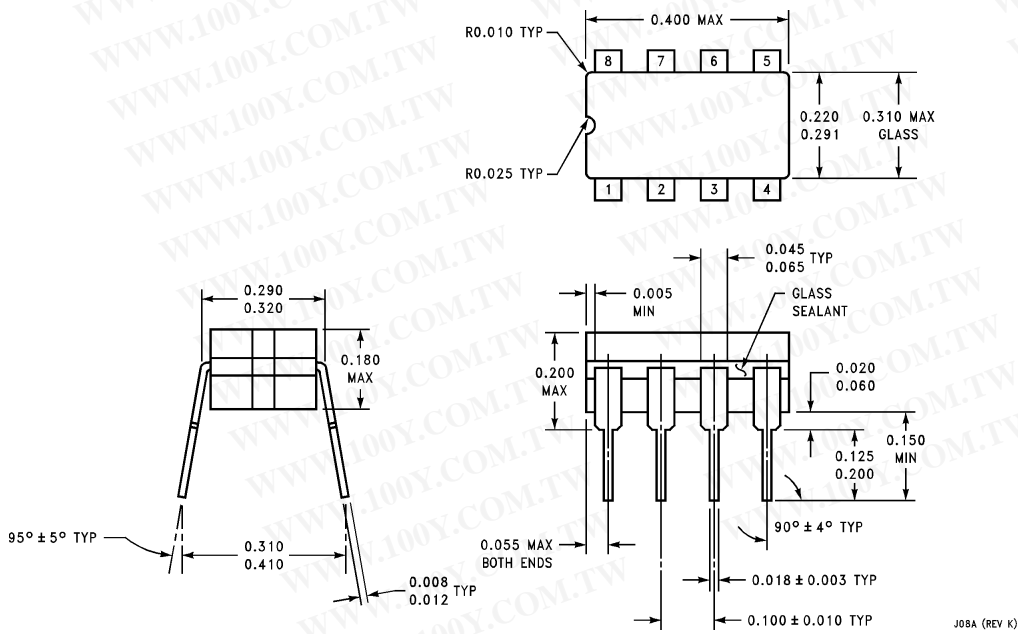

Ceramic Dual-In-Line Package (J)
 Order Number LM118J-8/883
 NS Package Number J08A

Physical Dimensions inches (millimeters) unless otherwise noted (Continued)

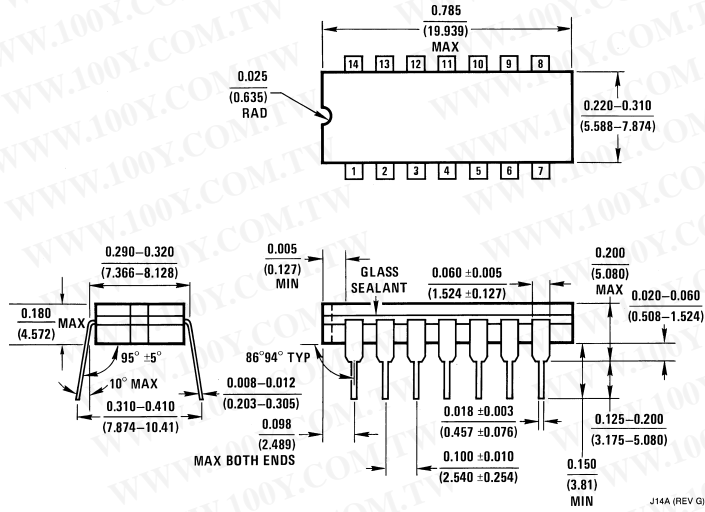

Ceramic Dual-In-Line Package (J)
Order Number LM118J/883
NS Package Number J14A

勝特力材料 886-3-5753170
 勝特力电子(上海) 86-21-54151736
 勝特力电子(深圳) 86-755-83298787
[Http://www.100y.com.tw](http://www.100y.com.tw)

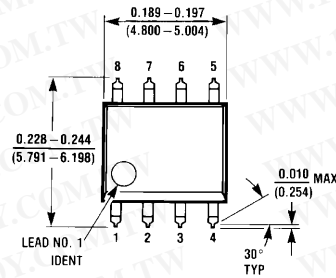

S.O. Package (M)
Order Number LM318M or LM318MX
NS Package Number M08A

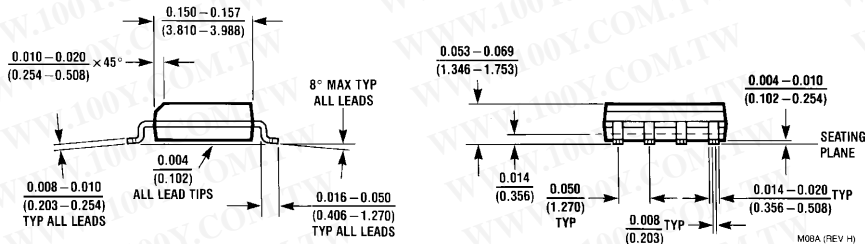

Physical Dimensions inches (millimeters) unless otherwise noted (Continued)

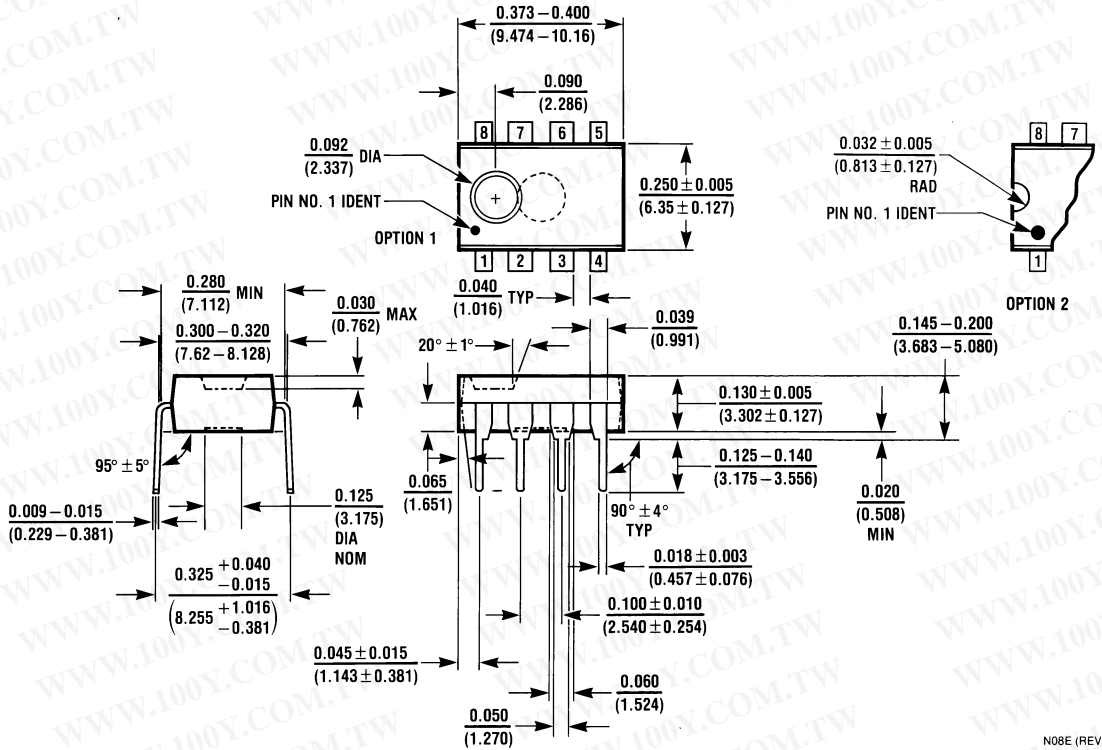

Molded Dual-In-Line Package (N)
Order Number LM318N
NS Package Number N08E

勝特力材料 886-3-5753170
 勝特力电子(上海) 86-21-54151736
 勝特力电子(深圳) 86-755-83298787
[Http://www.100y.com.tw](http://www.100y.com.tw)

LIFE SUPPORT POLICY

NATIONAL'S PRODUCTS ARE NOT AUTHORIZED FOR USE AS CRITICAL COMPONENTS IN LIFE SUPPORT DEVICES OR SYSTEMS WITHOUT THE EXPRESS WRITTEN APPROVAL OF THE PRESIDENT AND GENERAL COUNSEL OF NATIONAL SEMICONDUCTOR CORPORATION. As used herein:

1. Life support devices or systems are devices or systems which, (a) are intended for surgical implant into the body, or (b) support or sustain life, and whose failure to perform when properly used in accordance with instructions for use provided in the labeling, can be reasonably expected to result in a significant injury to the user.
2. A critical component is any component of a life support device or system whose failure to perform can be reasonably expected to cause the failure of the life support device or system, or to affect its safety or effectiveness.

