

LM124, LM124A, LM224, LM224A LM324, LM324A, LM2902 QUADRUPLE OPERATIONAL AMPLIFIERS

SLOS066F – SEPTEMBER 1975 – REVISED JANUARY 2002

- **Wide Range of Supply Voltages:**
 Single Supply . . . 3 V to 30 V
 (LM2902 3 V to 26 V) or Dual Supplies
- **Low Supply Current Drain Independent of Supply Voltage . . . 0.8 mA Typ**
- **Common-Mode Input Voltage Range Includes Ground Allowing Direct Sensing Near Ground**
- **Low Input Bias and Offset Parameters:**
 - Input Offset Voltage . . . 3 mV Typ
 A Versions . . . 2 mV Typ
 - Input Offset Current . . . 2 nA Typ
 - Input Bias Current . . . 20 nA Typ
 A Versions . . . 15 nA Typ
- **Differential Input Voltage Range Equal to Maximum-Rated Supply Voltage . . . 32 V (26 V for LM2902)**
- **Open-Loop Differential Voltage Amplification . . . 100 V/mV Typ**
- **Internal Frequency Compensation**

description

These devices consist of four independent high-gain frequency-compensated operational amplifiers that are designed specifically to operate from a single supply over a wide range of voltages. Operation from split supplies is also possible when the difference between the two supplies is 3 V to 30 V (for the LM2902, 3 V to 26 V) and V_{CC} is at least 1.5 V more positive than the input common-mode voltage. The low supply current drain is independent of the magnitude of the supply voltage.

Applications include transducer amplifiers, dc amplification blocks, and all the conventional operational-amplifier circuits that now can be more easily implemented in single-supply-voltage systems. For example, the LM124 can be operated directly from the standard 5-V supply that is used in digital systems and easily provides the required interface electronics without requiring additional ± 15 -V supplies.

The LM124 and LM124A are characterized for operation over the full military temperature range of -55°C to 125°C . The LM224 and LM224A are characterized for operation from -25°C to 85°C . The LM324 and LM324A are characterized for operation from 0°C to 70°C . The LM2902 is characterized for operation from -40°C to 125°C .

LM124, LM124A . . . J OR W PACKAGE
 LM224, LM224A, LM324, LM324A,
 LM2902 . . . D, DB, N, OR PW PACKAGE
 (TOP VIEW)

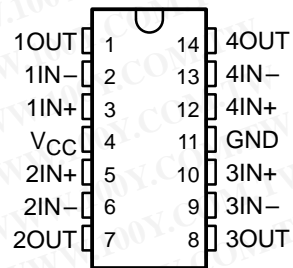

LM124, LM124A . . . FK PACKAGE
 (TOP VIEW)

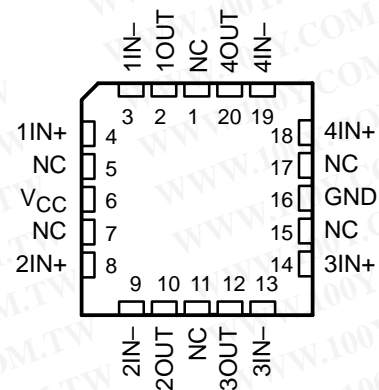

NC – No internal connection

**LM124, LM124A, LM224, LM224A
LM324, LM324A, LM2902
QUADRUPLE OPERATIONAL AMPLIFIERS**

SLOS066F – SEPTEMBER 1975 – REVISED JANUARY 2002

勝特力材料 886-3-5753170
 勝特力电子(上海) 86-21-54151736
 勝特力电子(深圳) 86-755-83298787
[Http://www.100y.com.tw](http://www.100y.com.tw)

AVAILABLE OPTIONS

| T _A | V _{IO} MAX AT 25°C | SMALL OUTLINE (D) | VERY SMALL OUTLINE (DB) | CHIP CARRIER (FK) | CERAMIC DIP (J) | PLASTIC DIP (N) | TSSOP (PW) | FLAT PACK (W) |
|----------------|--------------------------------|-------------------------|-------------------------------|-------------------------|-----------------------|-----------------------|---------------|---------------------|
| 0°C to 70°C | 7 mV | LM324D | LM324DB | — | — | LM324N | LM324PW | — |
| | 3 mV | LM324AD | — | — | — | LM324AN | LM324APW | — |
| -25°C to 85°C | 5 mV | LM224D | — | — | — | LM224N | — | — |
| | 3 mV | LM224AD | — | — | — | LM224AN | — | — |
| -40°C to 125°C | 7 mV | LM2902D | LM2902DB | — | — | LM2902N | LM2902PW | — |
| -55°C to 125°C | 5 mV | LM124D | — | LM124FK | LM124J | — | — | LM124W |
| | 2 mV | — | — | LM124AFK | LM124AJ | — | — | — |

The D package is available taped and reeled. Add the suffix R to the device type (e.g., LM324DR). The DB and PW packages are only available taped and reeled.

symbol (each amplifier)

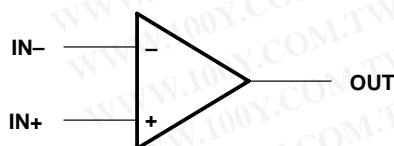

schematic (each amplifier)

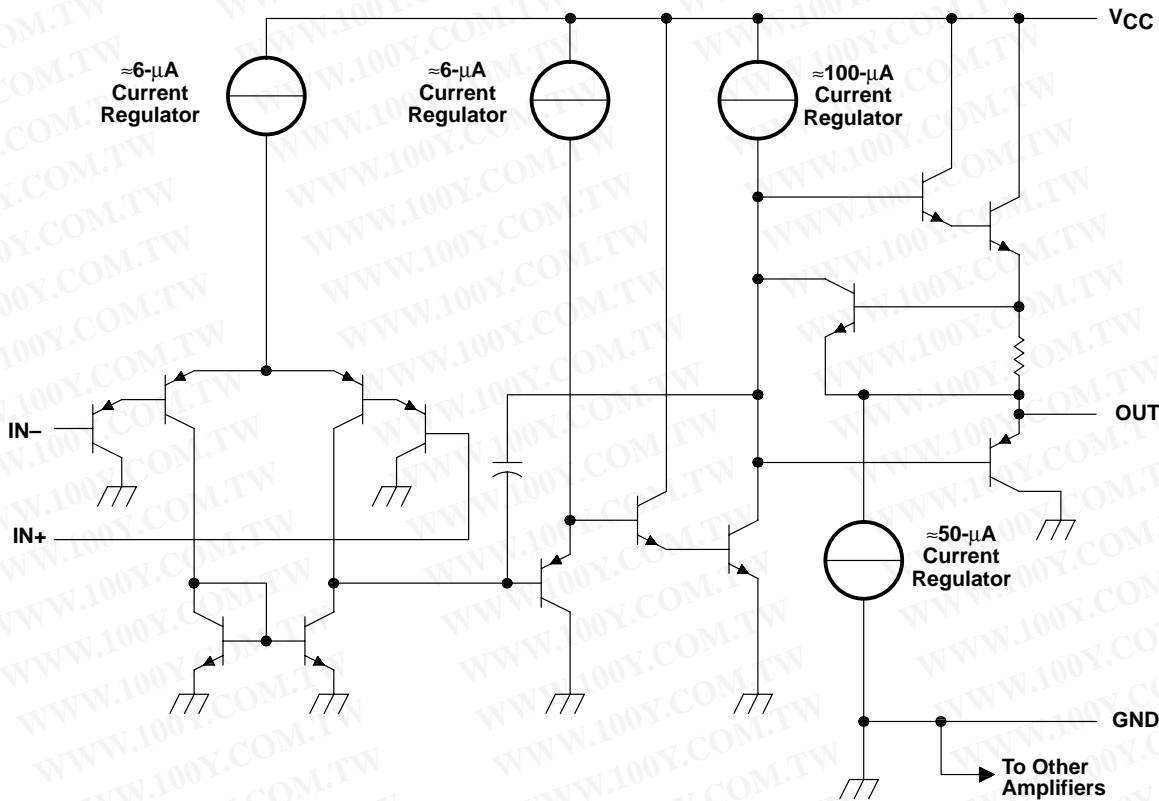

| COMPONENT COUNT (total device) | |
|-----------------------------------|----|
| Epi-FET | 1 |
| Transistors | 95 |
| Diodes | 4 |
| Resistors | 11 |
| Capacitors | 4 |

**LM124, LM124A, LM224, LM224A
LM324, LM324A, LM2902
QUADRUPLE OPERATIONAL AMPLIFIERS**

SLOS066F – SEPTEMBER 1975 – REVISED JANUARY 2002

勝特力材料 886-3-5753170
勝特力电子(上海) 86-21-54151736
勝特力电子(深圳) 86-755-83298787
Http://www.100y.com.tw

absolute maximum ratings over operating free-air temperature range (unless otherwise noted)†

| | | LM124, LM124A LM224, LM224A LM324, LM324A | LM2902 | UNIT |
|--------------------------------------------------------------------------------------------------------------------------------------------|-------------------------|-------------------------------------------------|------------|--------------------|
| Supply voltage, V_{CC} (see Note 1) | | 32 | 26 | V |
| Differential input voltage, V_{ID} (see Note 2) | | ± 32 | ± 26 | V |
| Input voltage, V_I (either input) | | -0.3 to 32 | -0.3 to 26 | V |
| Duration of output short circuit (one amplifier) to ground at (or below) $T_A = 25^\circ\text{C}$, $V_{CC} \leq 15\text{ V}$ (see Note 3) | | Unlimited | Unlimited | |
| Continuous total dissipation | | See Dissipation Rating Table | | |
| Package thermal impedance, θ_{JA} (see Note 4) | D package | 86 | | $^\circ\text{C/W}$ |
| | DB package | 96 | | |
| | N package | 80 | | |
| | PW package | 113 | | |
| Case temperature for 60 seconds | FK package | 260 | | $^\circ\text{C}$ |
| Lead temperature 1,6 mm (1/16 inch) from case for 60 seconds | J or W package | 300 | 300 | $^\circ\text{C}$ |
| Lead temperature 1,6 mm (1/16 inch) from case for 10 seconds | D, DB, N, or PW package | 260 | 260 | $^\circ\text{C}$ |
| Storage temperature range, T_{stg} | | -65 to 150 | -65 to 150 | $^\circ\text{C}$ |

† Stresses beyond those listed under “absolute maximum ratings” may cause permanent damage to the device. These are stress ratings only, and functional operation of the device at these or any other conditions beyond those indicated under “recommended operating conditions” is not implied. Exposure to absolute-maximum-rated conditions for extended periods may affect device reliability.

- NOTES: 1. All voltage values (except differential voltages and V_{CC} specified for the measurement of I_{OS}) are with respect to the network GND.
2. Differential voltages are at $IN+$ with respect to $IN-$.
3. Short circuits from outputs to V_{CC} can cause excessive heating and eventual destruction.
4. The package thermal impedance is calculated in accordance with JESD 51-7.

DISSIPATION RATING TABLE

| PACKAGE | $T_A \leq 25^\circ\text{C}$ POWER RATING | DERATING FACTOR | DERATE ABOVE T_A | $T_A = 70^\circ\text{C}$ POWER RATING | $T_A = 85^\circ\text{C}$ POWER RATING | $T_A = 125^\circ\text{C}$ POWER RATING |
|----------------|---------------------------------------------|---------------------------|-----------------------|------------------------------------------|------------------------------------------|-------------------------------------------|
| D | 900 mW | 7.6 mW/ $^\circ\text{C}$ | 32 $^\circ\text{C}$ | 611 mW | 497 mW | N/A |
| FK | 900 mW | 11.0 mW/ $^\circ\text{C}$ | 68 $^\circ\text{C}$ | 878 mW | 713 mW | 273 mW |
| J (LM124_) | 900 mW | 11.0 mW/ $^\circ\text{C}$ | 68 $^\circ\text{C}$ | 878 mW | 713 mW | 273 mW |
| J (all others) | 900 mW | 8.2 mW/ $^\circ\text{C}$ | 40 $^\circ\text{C}$ | 654 mW | 531 mW | N/A |
| W | 900 mW | 8.0 mW/ $^\circ\text{C}$ | 37 $^\circ\text{C}$ | 636 mW | 516 mW | 196 mW |



electrical characteristics at specified free-air temperature, $V_{CC} = 5\text{ V}$ (unless otherwise noted)

| PARAMETER | TEST CONDITIONST | T _A ‡ | LM124, LM224 | | | LM324 | | | LM2902 | | | UNIT | |
|----------------------------------|----------------------------------------------------------------------|-------------------------------------------------------------------------------------------------|--------------|---------------------------|------|---------------------------|------|---------------------------|--------|------|------|------|----|
| | | | MIN | TYP§ | MAX | MIN | TYP§ | MAX | MIN | TYP§ | MAX | | |
| V _{IO} | Input offset voltage | V _{CC} = 5 V to MAX, V _{IC} = V _{ICRmin} , V _O = 1.4 V | 25°C | 3 | 5 | 3 | 7 | 3 | 7 | | | mV | |
| | | | Full range | | | 7 | | 9 | | 10 | | | |
| I _{IO} | Input offset current | V _O = 1.4 V | 25°C | 2 | 30 | 2 | 50 | 2 | 50 | | | nA | |
| | | | Full range | | 100 | | 150 | | 300 | | | | |
| I _{IB} | Input bias current | V _O = 1.4 V | 25°C | -20 | -150 | -20 | -250 | -20 | -250 | | | nA | |
| | | | Full range | | -300 | | -500 | | -500 | | | | |
| V _{ICR} | Common-mode input voltage range | V _{CC} = 5 V to MAX | 25°C | 0 to V _{CC} -1.5 | | 0 to V _{CC} -1.5 | | 0 to V _{CC} -1.5 | | | V | | |
| | | | Full range | 0 to V _{CC} -2 | | 0 to V _{CC} -2 | | 0 to V _{CC} -2 | | | | | |
| V _{OH} | High-level output voltage | R _L = 2 kΩ | 25°C | V _{CC} -1.5 | | V _{CC} -1.5 | | V _{CC} -1.5 | | | V | | |
| | | R _L = 10 kΩ | 25°C | | | | | V _{CC} -1.5 | | | | | |
| | | V _{CC} = MAX, R _L = 2 kΩ | Full range | 26 | | 26 | | 22 | | | | | |
| | | V _{CC} = MAX, R _L ≥ 10 kΩ | Full range | 27 | 28 | 27 | 28 | 23 | 24 | | | | |
| V _{OL} | Low-level output voltage | R _L ≤ 10 kΩ | Full range | 5 | 20 | 5 | 20 | 5 | 20 | | mV | | |
| A _{VD} | Large-signal differential voltage amplification | V _{CC} = 15 V, V _O = 1 V to 11 V, R _L ≥ 2 kΩ | 25°C | 50 | 100 | 25 | 100 | | 100 | | V/mV | | |
| | | | Full range | 25 | | 15 | | 15 | | | | | |
| CMRR | Common-mode rejection ratio | V _{IC} = V _{ICRmin} | 25°C | 70 | 80 | 65 | 80 | 50 | 80 | | dB | | |
| k _{SVR} | Supply-voltage rejection ratio (ΔV _{CC} /ΔV _{IO}) | | 25°C | 65 | 100 | 65 | 100 | 50 | 100 | | dB | | |
| V _{O1} /V _{O2} | Crosstalk attenuation | f = 1 kHz to 20 kHz | 25°C | 120 | | 120 | | 120 | | | dB | | |
| I _O | Output current | V _{CC} = 15 V, V _{ID} = 1 V, V _O = 0 | 25°C | -20 | -30 | -60 | -20 | -30 | -60 | -20 | -30 | -60 | mA |
| | | | Full range | -10 | | -10 | | -10 | | | | | |
| | | V _{CC} = 15 V, V _O = 15 V | 25°C | 10 | 20 | 10 | 20 | 10 | 20 | | | μA | |
| | | | Full range | 5 | | 5 | | 5 | | | | | |
| I _{OS} | Short-circuit output current | V _{CC} at 5 V, GND at -5 V, V _O = 0 | 25°C | ±40 | ±60 | ±40 | ±60 | ±40 | ±60 | | | mA | |
| | | | Full range | 0.7 | 1.2 | 0.7 | 1.2 | 0.7 | 1.2 | | | | |
| I _{CC} | Supply current (four amplifiers) | V _O = 2.5 V, No load | Full range | 0.7 | 1.2 | 0.7 | 1.2 | 0.7 | 1.2 | | mA | | |
| | | V _{CC} = MAX, V _O = 0.5 V _{CC} , No load | Full range | 1.4 | 3 | 1.4 | 3 | 1.4 | 3 | | | | |

† All characteristics are measured under open-loop conditions with zero common-mode input voltage unless otherwise specified. MAX V_{CC} for testing purposes is 26 V for LM2902, 30 V for the others.

‡ Full range is -55°C to 125°C for LM124, -25°C to 85°C for LM224, 0°C to 70°C for LM324, and -40°C to 125°C for LM2902.

§ All typical values are at T_A = 25°C.

LM124, LM124A, LM224, LM224A
 LM324, LM324A, LM2902
QUADRUPLER OPERATIONAL AMPLIFIERS
 SLOS066 - SEPTEMBER 1975 - REVISED JANUARY 2002

electrical characteristics at specified free-air temperature, $V_{CC} = 5\text{ V}$ (unless otherwise noted)

| PARAMETER | TEST CONDITIONS† | T_A ‡ | LM124A | | | LM224A | | | LM324A | | | UNIT |
|----------------------------------------------------------------------------|------------------------------------------------------------------------------------------------|------------|-------------------|----------|-------------------|--------|----------|-------------------|--------|----------|---------------|------|
| | | | MIN | TYP§ | MAX | MIN | TYP§ | MAX | MIN | TYP§ | MAX | |
| V_{IO} Input offset voltage | $V_{CC} = 5\text{ V to } 30\text{ V}$, $V_{IC} = V_{ICRmin}$, $V_O = 1.4\text{ V}$ | 25°C | | | 2 | | 2 | 3 | | 2 | 3 | mV |
| | | Full range | | | 4 | | | 4 | | | 5 | |
| I_{IO} Input offset current | $V_O = 1.4\text{ V}$ | 25°C | | | 10 | | | 2 | 15 | 2 | 30 | nA |
| | | Full range | | | 30 | | | 30 | | | 75 | |
| I_{IB} Input bias current | $V_O = 1.4\text{ V}$ | 25°C | | | -50 | | -15 | -80 | | -15 | -100 | nA |
| | | Full range | | | -100 | | | -100 | | | -200 | |
| V_{ICR} Common-mode input voltage range | $V_{CC} = 30\text{ V}$ | 25°C | 0 to $V_{CC}-1.5$ | | 0 to $V_{CC}-1.5$ | | | 0 to $V_{CC}-1.5$ | | | | V |
| | | Full range | 0 to $V_{CC}-2$ | | 0 to $V_{CC}-2$ | | | 0 to $V_{CC}-2$ | | | | |
| V_{OH} High-level output voltage | $R_L = 2\text{ k}\Omega$ | 25°C | $V_{CC}-1.5$ | | $V_{CC}-1.5$ | | | $V_{CC}-1.5$ | | | | V |
| | $V_{CC} = 30\text{ V}$, $R_L = 2\text{ k}\Omega$ | Full range | 26 | | 26 | | | 26 | | | | |
| | $V_{CC} = 30\text{ V}$, $R_L \geq 10\text{ k}\Omega$ | Full range | 27 | | 27 | 28 | | 27 | 28 | | | |
| V_{OL} Low-level output voltage | $R_L \leq 10\text{ k}\Omega$ | Full range | | | 20 | | 5 | 20 | | 5 | 20 | mV |
| A_{VD} Large-signal differential voltage amplification | $V_{CC} = 15\text{ V}$, $V_O = 1\text{ V to } 11\text{ V}$, $R_L = \geq 2\text{ k}\Omega$ | Full range | 25 | | 25 | | | 15 | | | | V/mV |
| CMRR Common-mode rejection ratio | $V_{IC} = V_{ICRmin}$ | 25°C | 70 | | 70 | 80 | | 65 | 80 | | | dB |
| k_{SVR} Supply-voltage rejection ratio ($\Delta V_{CC}/\Delta V_{IO}$) | | 25°C | 65 | | 65 | 100 | | 65 | 100 | | | dB |
| V_{O1}/V_{O2} Crosstalk attenuation | $f = 1\text{ kHz to } 20\text{ kHz}$ | 25°C | | 120 | | 120 | | | 120 | | | dB |
| I_O Output current | $V_{CC} = 15\text{ V}$, $V_{ID} = 1\text{ V}$, $V_O = 0$ | 25°C | -20 | | -20 | -30 | -60 | -20 | -30 | -60 | | mA |
| | | Full range | -10 | | -10 | | | -10 | | | | |
| | $V_{CC} = 15\text{ V}$, $V_{ID} = -1\text{ V}$, $V_O = 15\text{ V}$ | 25°C | 10 | | 10 | 20 | | 10 | 20 | | | |
| | | Full range | 5 | | 5 | | | 5 | | | | |
| $V_{ID} = -1\text{ V}$, $V_O = 200\text{ mV}$ | 25°C | 12 | | 12 | 30 | | 12 | 30 | | | μA | |
| | Full range | | | | | | | | | | | |
| I_{OS} Short-circuit output current | V_{CC} at 5 V, $V_O = 0$, GND at -5 V | 25°C | | ± 40 | ± 60 | | ± 40 | ± 60 | | ± 40 | ± 60 | mA |
| I_{CC} Supply current (four amplifiers) | $V_O = 2.5\text{ V}$, No load | Full range | | 0.7 | 1.2 | | 0.7 | 1.2 | | 0.7 | 1.2 | mA |
| | $V_{CC} = 30\text{ V}$, $V_O = 15\text{ V}$, No load | Full range | | 1.4 | 3 | | 1.4 | 3 | | 1.4 | 3 | |

† All characteristics are measured under open-loop conditions with zero common-mode input voltage unless otherwise specified.

‡ Full range is -55°C to 125°C for LM124A, -25°C to 85°C for LM224A, and 0°C to 70°C for LM324A.

§ All typical values are at $T_A = 25^\circ\text{C}$.

勝特力材料 886-3-5753170
 勝特力电子(上海) 86-21-54151736
 勝特力电子(深圳) 86-755-83298787
 Http://www.100y.com.tw