

February 1995

LM3909 LED Flasher/Oscillator

LM3909 LED Flasher/Oscillator

General Description

The LM3909 is a monolithic oscillator specifically designed to flash Light Emitting Diodes. By using the timing capacitor for voltage boost, it delivers pulses of 2 or more volts to the LED while operating on a supply of 1.5V or less. The circuit is inherently self-starting, and requires addition of only a battery and capacitor to function as an LED flasher.

Packaged in an 8-lead plastic mini-DIP, the LM3909 will operate over the extended consumer temperature range of -25°C to $+70^{\circ}\text{C}$. It has been optimized for low power drain and operation from weak batteries so that continuous operation life exceeds that expected from battery rating.

Application is made simple by inclusion of internal timing resistors and an internal LED current limit resistor. As shown in the first two application circuits, the timing resistors supplied are optimized for nominal flashing rates and minimum power drain at 1.5V and 3V.

Timing capacitors will generally be of the electrolytic type, and a small 3V rated part will be suitable for any LED flasher using a supply up to 6V. However, when picking flash rates, it should be remembered that some electrolytics have very broad capacitance tolerances, for example -20% to $+100\%$.

Features

- Operation over one year from one C size flashlight cell
- Bright, high current LED pulse
- Minimum external parts
- Low cost
- Low voltage operation, from just over 1V to 5V
- Low current drain, averages under 0.5 mA during battery life
- Powerful; as an oscillator directly drives an 8Ω speaker
- Wide temperature range

Applications

- Finding flashlights in the dark, or locating boat mooring floats
- Sales and advertising gimmicks
- Emergency locators, for instance on fire extinguishers
- Toys and novelties
- Electronic applications such as trigger and sawtooth generators
- Siren for toy fire engine, (combined oscillator, speaker driver)
- Warning indicators powered by 1.4V to 200V

Schematic Diagram

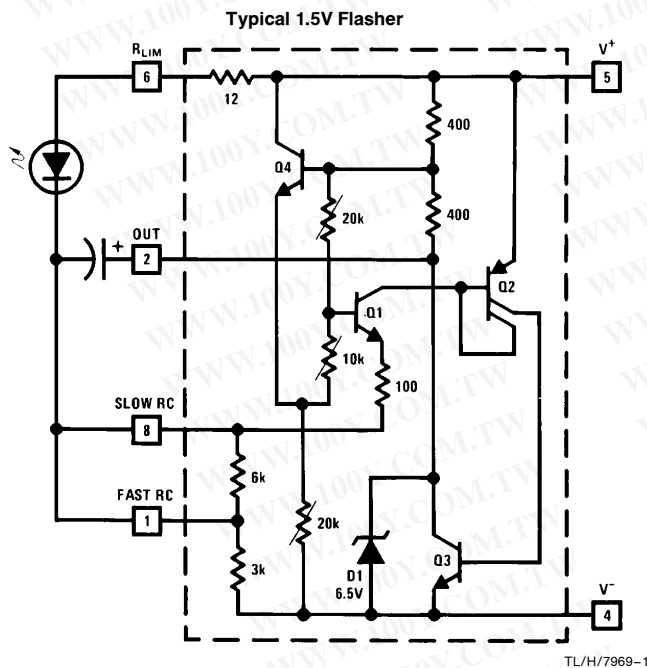

Connection Diagram

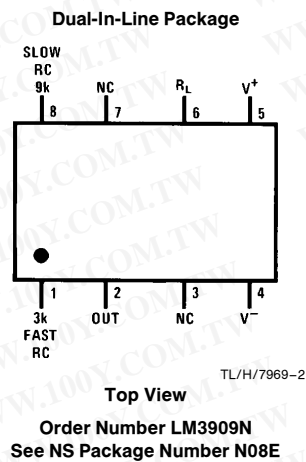

Absolute Maximum Ratings

If Military/Aerospace specified devices are required, please contact the National Semiconductor Sales Office/Distributors for availability and specifications.

Power Dissipation 500 mW
 V⁺ Voltage 6.4V

Operating Temperature Range -25°C to +70°C
 Lead Temperature (Soldering, 10 sec.) 260°C

Electrical Characteristics

Parameter	Conditions (Applications Note 3)	Min	Typ	Max	Units
Supply Voltage	(In Oscillation)	1.15		6.0	V
Operating Current			0.55	0.75	mA
Flash Frequency	300 μF, 5% Capacitor	0.65	1.0	1.3	Hz
High Flash Frequency	0.30 μF, 5% Capacitor		1.1		kHz
Compatible LED Forward Drop	1 mA Forward Current	1.35		2.1	V
Peak LED Current	350 μF Capacitor		45		mA
Pulse Width	350 μF Capacitors at 1/2 Amplitude		6.0		ms

Typical Applications (See applications notes on following page)

Triac Trigger

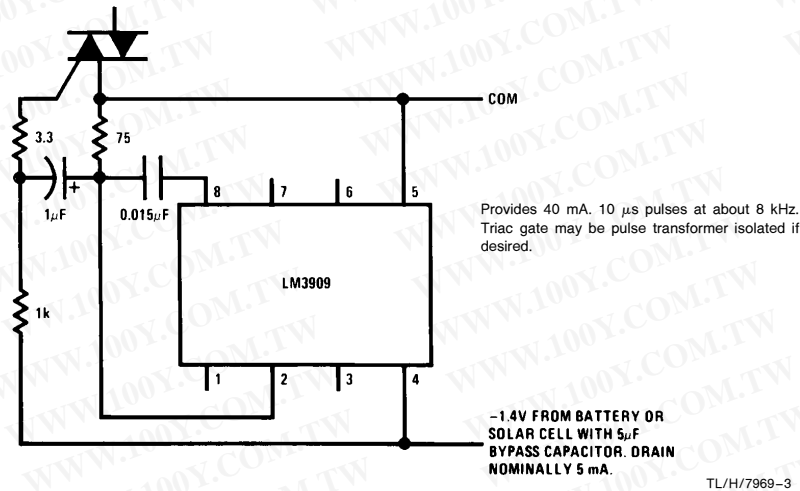

Typical Applications (Continued)(See applications notes below)

Warning Flasher High Voltage Powered

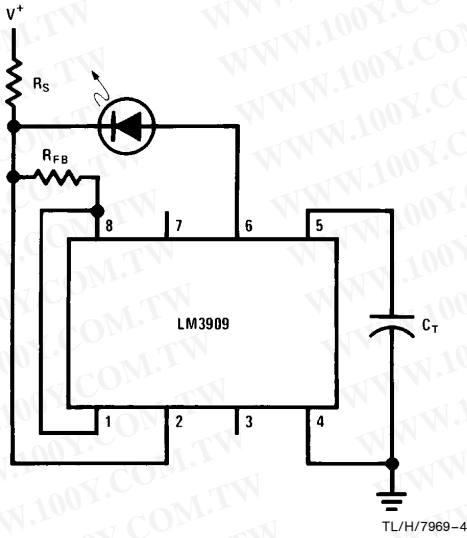

TL/H/7969-4

Typical Operating Conditions

V ⁺	Nominal Flash Hz	C _T	R _S	R _{FB}	V ⁺ RANGE
6V	2	400 µF	1k	1.5k	5V-25V
15V	2	180 µF	3.9k	1k	13V-50V
100V	1.7	180 µF	43k	1k	85V-200V

1.5V Flasher

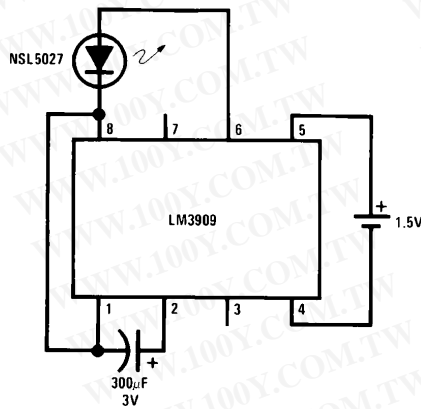

TL/H/7969-5

Note: Nominal flash rate: 1 Hz.

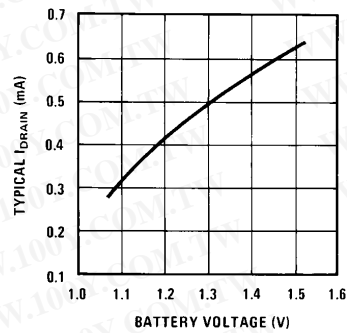

TL/H/7969-6

Estimated Battery Life (Continuous 1.5V Flasher Operation)

Size Cell	Type	
	Standard	Alkaline
AA	3 months	6 months
C	7 months	15 months
D	1.3 years	2.6 years

Note: Estimates are made from our tests and manufacturers data. Conditions are fresh batteries and room temperature. Clad or "leak-proof" batteries are recommended for any application of five months or more. Nickel Cadmium cells are not recommended.

APPLICATIONS NOTES

Note 1: All capacitors shown are electrolytic unless marked otherwise.

Note 2: Flash rates and frequencies assume a ±5% capacitor tolerance. Electrolytics may vary -20% to +100% of their stated value.

Note 3: Unless noted, measurements above are made with a 1.4V supply, a 25°C ambient temperature, and an LED with a forward drop of 1.5V to 1.7V at 1 mA forward current.

Note 4: Occasionally a flasher circuit will fail to oscillate due to an LED defect that may be missed because it only reduces light output 10% or so. Such LEDs can be identified by a large increase in conduction between 0.9V and 1.2V.

Typical Applications (Continued) (See applications notes on previous page)

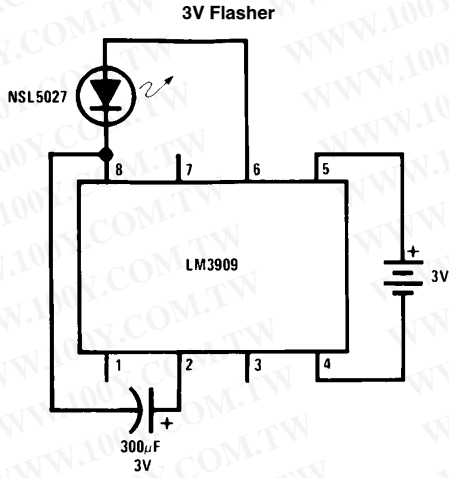

TL/H/7969-7

Note: Nominal flash rate: 1 Hz. Average $I_{DRAIN} = 0.77$ mA.

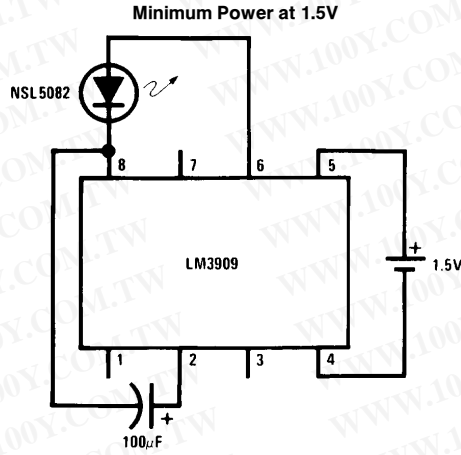

TL/H/7969-8

Note: Nominal flash rate: 1.1 Hz. Average $I_{DRAIN} = 0.32$ mA.

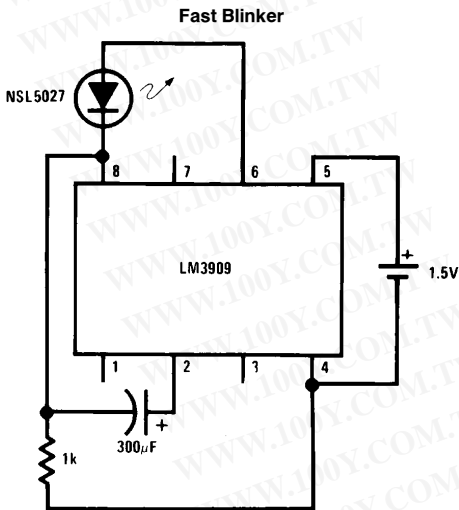

TL/H/7969-9

Note: Nominal flash rate: 2.6 Hz. Average $I_{DRAIN} = 1.2$ mA.

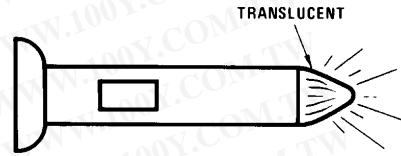

TL/H/7969-11

Note: Winking LED inside, locates light in total darkness.

Typical Applications (Continued) (See applications notes above)

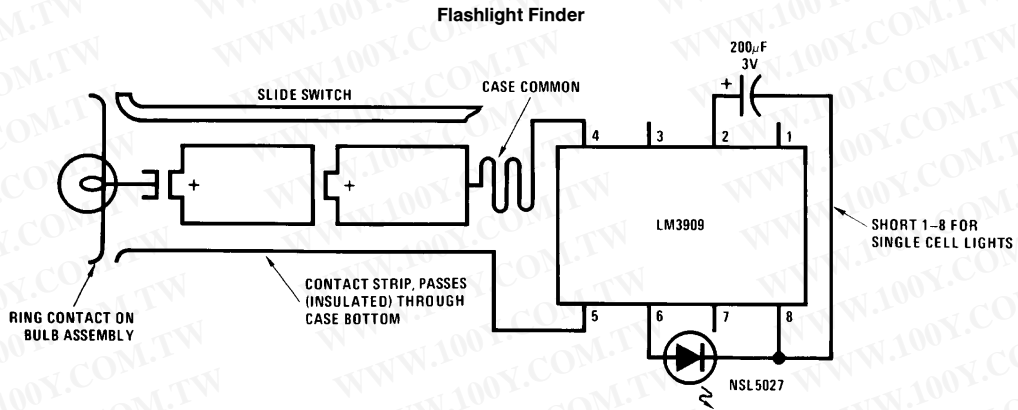

TL/H/7969-10

Note: LM3909, capacitor, and LED are installed in a white translucent cap on the flashlight's back end. Only one contact strip (in addition to the case connection) is needed for flasher power. Drawing current through the bulb simplifies wiring and causes negligible loss since bulb resistance cold is typically less than 2Ω .

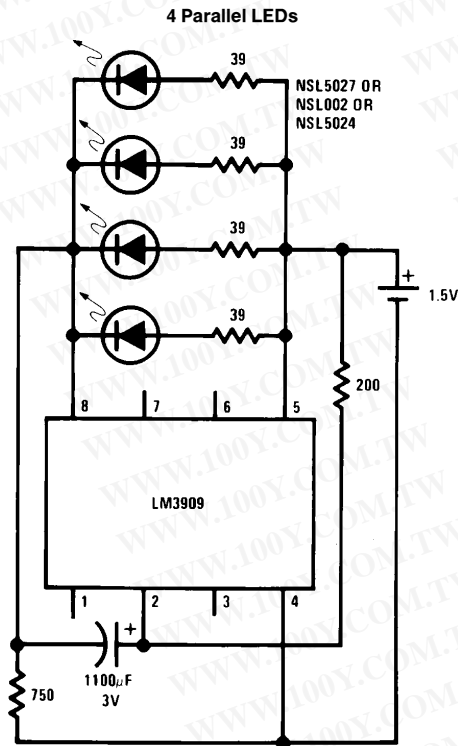

TL/H/7969-12

Note: Nominal flash rate: 1.3 Hz. Average $I_{DRAIN} = 2$ mA.

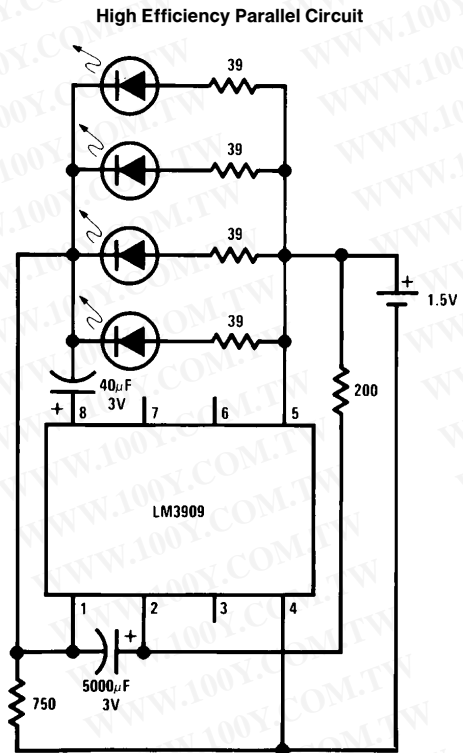

TL/H/7969-13

Note: Nominal flash rate: 1.5 Hz. Average $I_{DRAIN} = 1.5$ mA.

Typical Applications (Continued) (See applications notes above)

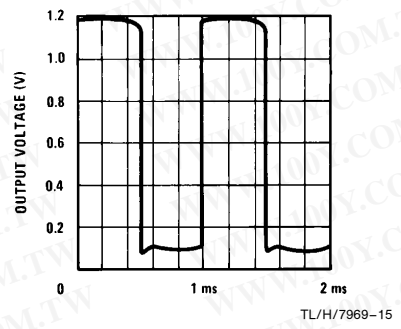
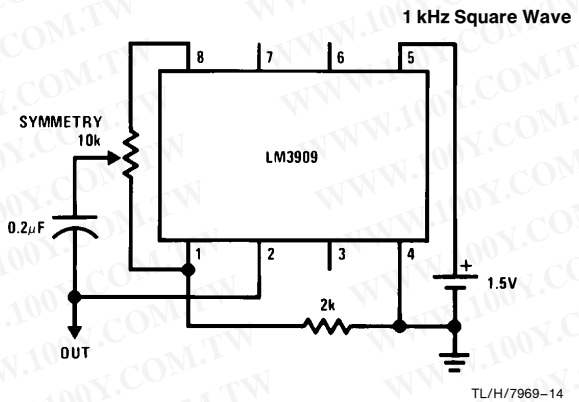

Note: Output voltage through a 10k load to ground.

"Buzz Box" Continuity and Coil Checker

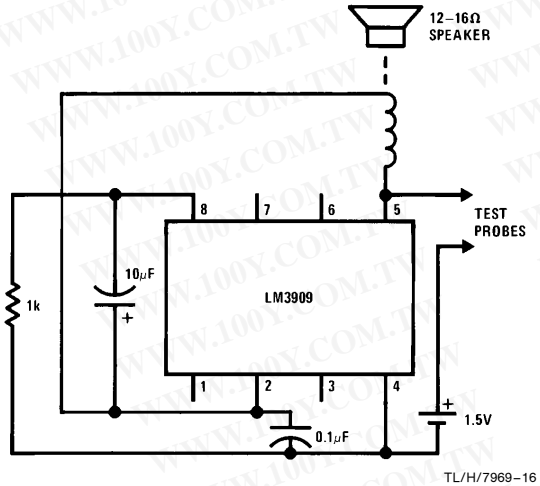

Note: Differences between shorts, coils, and a few ohms of resistance can be heard.

Variable Flasher

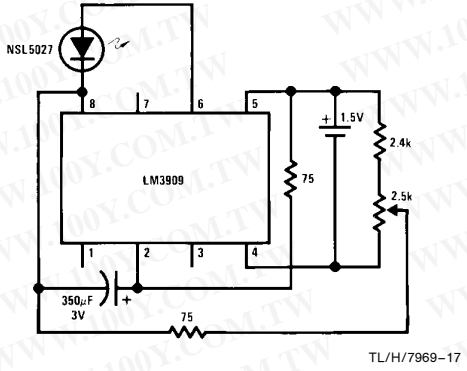

Note: Flash rate: 0 Hz-20 Hz.

Typical Applications (Continued) (See applications notes above)

LED Booster

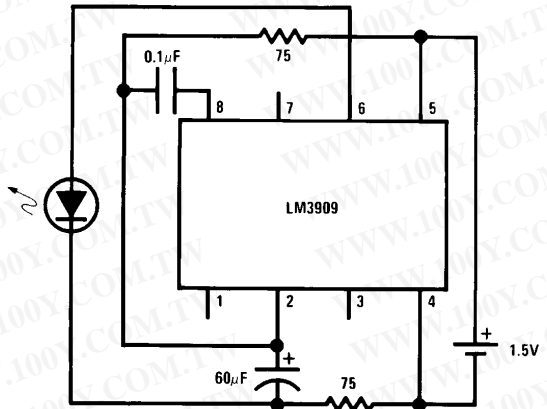

TL/H/7969-18

Note: High efficiency, 4 mA drain. Continuous appearing light obtained by supplying short, high current, pulses (2 kHz) to LEDs with higher than battery voltage available.

Incandescent Bulb Flasher

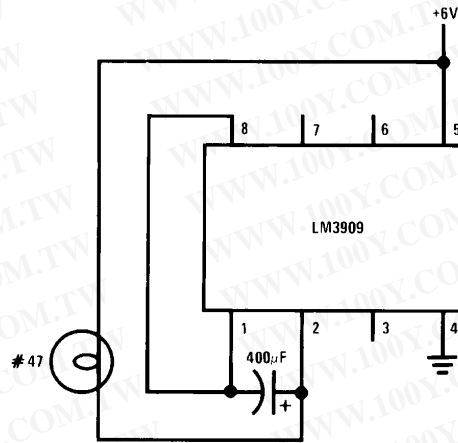

TL/H/7969-19

Note: Flash rate: 1.5 Hz.

Emergency Lantern/Flasher

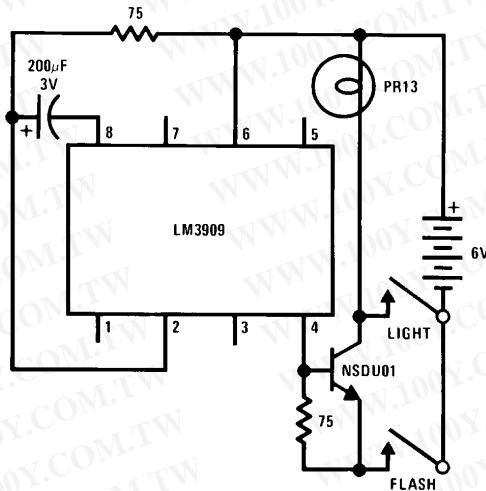

TL/H/7969-20

Note: Nominal flash rate: 1.5 Hz.

LM3909 LED Flasher/Oscillator

Physical Dimensions inches (millimeters)

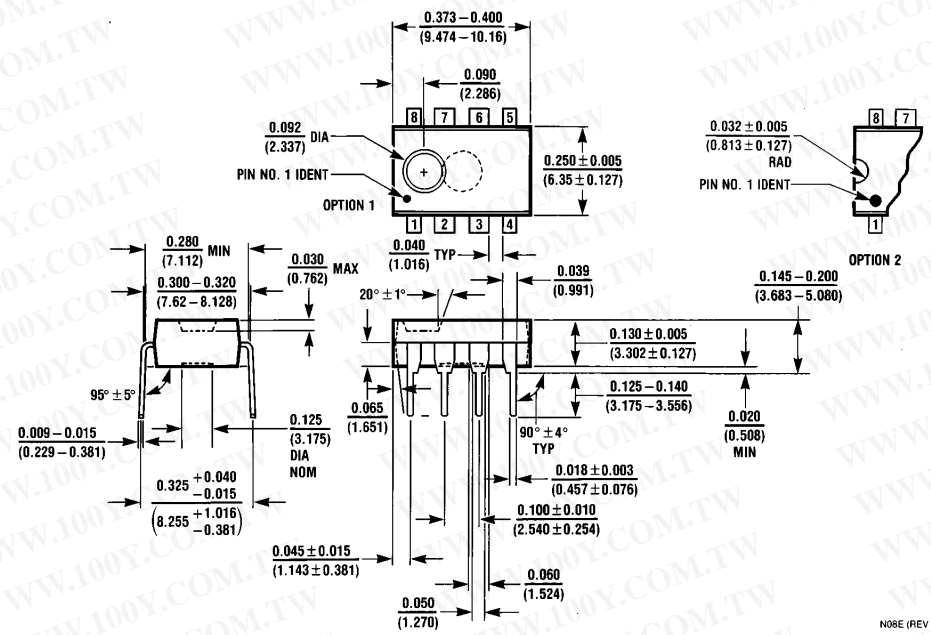

Molded Dual-In-Line Package (N)
 Order Number LM3909N
 NS Package Number N08E

N08E (REV F)

LIFE SUPPORT POLICY

NATIONAL'S PRODUCTS ARE NOT AUTHORIZED FOR USE AS CRITICAL COMPONENTS IN LIFE SUPPORT DEVICES OR SYSTEMS WITHOUT THE EXPRESS WRITTEN APPROVAL OF THE PRESIDENT OF NATIONAL SEMICONDUCTOR CORPORATION. As used herein:

- Life support devices or systems are devices or systems which, (a) are intended for surgical implant into the body, or (b) support or sustain life, and whose failure to perform, when properly used in accordance with instructions for use provided in the labeling, can be reasonably expected to result in a significant injury to the user.
- A critical component is any component of a life support device or system whose failure to perform can be reasonably expected to cause the failure of the life support device or system, or to affect its safety or effectiveness.

 <p> National Semiconductor Corporation 1111 West Bardin Road Arlington, TX 76017 Tel: 1(800) 272-9959 Fax: 1(800) 737-7018 </p>	<p> National Semiconductor Europe Fax: (+49) 0-180-530 85 86 Email: cnjwge@tevm2.nsc.com Deutsch Tel: (+49) 0-180-530 85 85 English Tel: (+49) 0-180-532 78 32 Français Tel: (+49) 0-180-532 93 58 Italiano Tel: (+49) 0-180-534 16 80 </p>	<p> National Semiconductor Hong Kong Ltd. 19th Floor, Straight Block, Ocean Centre, 5 Canton Rd. Tsimshatsui, Kowloon Hong Kong Tel: (852) 2737-1600 Fax: (852) 2736-9960 </p>	<p> National Semiconductor Japan Ltd. Tel: 81-043-299-2309 Fax: 81-043-299-2408 </p>
--	--	---	---

National does not assume any responsibility for use of any circuitry described, no circuit patent licenses are implied and National reserves the right at any time without notice to change said circuitry and specifications.