



## 64Kbit and 32Kbit Serial SPI Bus EEPROM With High Speed Clock

### FEATURES SUMMARY

- Compatible with SPI Bus Serial Interface (Positive Clock SPI Modes)
- Single Supply Voltage:
  - 4.5 to 5.5V for M95xxx
  - 2.5 to 5.5V for M95xxx-W
  - 1.8 to 5.5V for M95xxx-R
- 10MHz, 5MHz or 2MHz clock rate (depending on ordering options)
- 5ms or 10ms Write Time (depending on ordering options)
- Status Register
- Hardware Protection of the Status Register
- BYTE and PAGE WRITE (up to 32 Bytes)
- Self-Timed Programming Cycle
- Adjustable Size Read-Only EEPROM Area
- Enhanced ESD Protection
- More than 100,000 or 1 million Erase/Write Cycles (depending on ordering options)
- More than 40 Year Data Retention

Figure 1. Packages

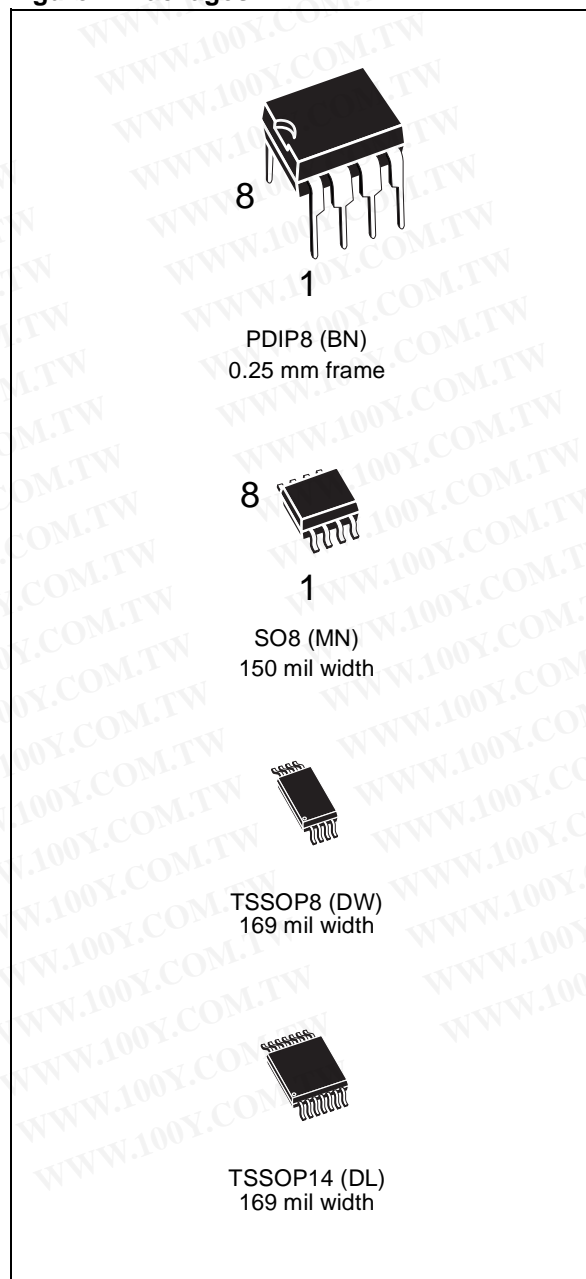

## TABLE OF CONTENTS

<b>FEATURES SUMMARY</b> .....	<b>1</b>
Figure 1. Packages .....	1
<b>SUMMARY DESCRIPTION</b> .....	<b>5</b>
Figure 2. Logic Diagram .....	5
Figure 3. DIP and SO Connections .....	5
Figure 4. TSSOP14 Connections .....	5
Table 1. Signal Names .....	5
<b>SIGNAL DESCRIPTION</b> .....	<b>6</b>
Serial Data Output (Q) .....	6
Serial Data Input (D) .....	6
Serial Clock (C) .....	6
Chip Select (S) .....	6
Hold (HOLD) .....	6
Write Protect (W) .....	6
<b>CONNECTING TO THE SPI BUS</b> .....	<b>7</b>
Figure 5. Bus Master and Memory Devices on the SPI Bus .....	7
<b>SPI Modes</b> .....	<b>7</b>
Figure 6. SPI Modes Supported .....	8
<b>OPERATING FEATURES</b> .....	<b>9</b>
<b>Power-up</b> .....	<b>9</b>
<b>Power On Reset: VCC Lock-Out Write Protect</b> .....	<b>9</b>
<b>Power-down</b> .....	<b>9</b>
<b>Active Power and Stand-by Power Modes</b> .....	<b>9</b>
<b>Hold Condition</b> .....	<b>9</b>
Figure 7. Hold Condition Activation .....	9
<b>Status Register</b> .....	<b>10</b>
WIP bit .....	10
WEL bit .....	10
BP1, BP0 bits .....	10
SRWD bit .....	10
Table 2. Status Register Format .....	10
<b>Data Protection and Protocol Control</b> .....	<b>10</b>
Table 3. Write-Protected Block Size .....	10
<b>MEMORY ORGANIZATION</b> .....	<b>11</b>
Figure 8. Block Diagram .....	11

<b>INSTRUCTIONS</b> .....	<b>12</b>
Table 4. Instruction Set .....	12
Figure 9. Write Enable (WREN) Sequence .....	12
<b>Write Enable (WREN)</b> .....	<b>12</b>
Figure 10. Write Disable (WRDI) Sequence .....	13
<b>Write Disable (WRDI)</b> .....	<b>13</b>
Figure 11. Read Status Register (RDSR) Sequence .....	14
<b>Read Status Register (RDSR)</b> .....	<b>14</b>
WIP bit .....	14
WEL bit .....	14
BP1, BP0 bits .....	14
SRWD bit .....	14
Figure 12. Write Status Register (WRSR) Sequence .....	15
<b>Write Status Register (WRSR)</b> .....	<b>15</b>
Table 5. Protection Modes .....	16
Table 6. Address Range Bits .....	16
Figure 13. Read from Memory Array (READ) Sequence .....	17
<b>Read from Memory Array (READ)</b> .....	<b>17</b>
Figure 14. Byte Write (WRITE) Sequence .....	18
<b>Write to Memory Array (WRITE)</b> .....	<b>18</b>
Figure 15. Page Write (WRITE) Sequence .....	19
<b>POWER-UP AND DELIVERY STATE</b> .....	<b>20</b>
<b>Power-up State</b> .....	<b>20</b>
<b>INITIAL DELIVERY STATE</b> .....	<b>20</b>
<b>MAXIMUM RATING</b> .....	<b>21</b>
Table 7. Absolute Maximum Ratings .....	21
<b>DC and AC PARAMETERS</b> .....	<b>22</b>
Table 8. Operating Conditions (M95xxx) .....	22
Table 9. Operating Conditions (M95xxx-W) .....	22
Table 10. Operating Conditions (M95xxx-R) .....	22
Table 11. AC Measurement Conditions .....	22
Figure 16. AC Measurement I/O Waveform .....	22
Table 12. Capacitance .....	23
Table 13. DC Characteristics (M95xxx, temperature range 6) .....	23
Table 14. DC Characteristics (M95xxx, temperature range 3) .....	24
Table 15. DC Characteristics (M95xxx-W, temperature range 6) .....	24
Table 16. DC Characteristics (M95xxx-W, temperature range 3) .....	25
Table 17. DC Characteristics (M95xxx-R) .....	25
Table 18. AC Characteristics (M95xxx, temperature range 6) .....	26

Table 19. AC Characteristics (M95xxx, temperature range 3) . . . . . 27

Table 20. AC Characteristics (M95xxx-W, temperature range 6) . . . . . 28

Table 21. AC Characteristics (M95xxx-W, temperature range 3) . . . . . 29

Table 22. AC Characteristics (M95xxx-R) . . . . . 30

Figure 17. Serial Input Timing . . . . . 31

Figure 18. Hold Timing . . . . . 31

Figure 19. Output Timing. . . . . 32

**PACKAGE MECHANICAL . . . . . 33**

Figure 20. PDIP8 – 8 pin Plastic DIP, 0.25mm lead frame, Package Outline . . . . . 33

Table 23. PDIP8 – 8 pin Plastic DIP, 0.25mm lead frame, Package Mechanical Data . . . . . 33

Figure 21. SO8 narrow – 8 lead Plastic Small Outline, 150 mils body width, Package Outline. . . . . 34

Table 24. SO8 narrow – 8 lead Plastic Small Outline, 150 mils body width, Package Mechanical Data . . . . . 34

Figure 22. TSSOP8 – 8 lead Thin Shrink Small Outline, Package Outline . . . . . 35

Table 25. TSSOP8 – 8 lead Thin Shrink Small Outline, Package Mechanical Data . . . . . 35

Figure 23. TSSOP14 - 14 lead Thin Shrink Small Outline, Package Outline . . . . . 36

Table 26. TSSOP14 - 14 lead Thin Shrink Small Outline, Package Mechanical Data . . . . . 36

**PART NUMBERING . . . . . 37**

Table 27. Ordering Information Scheme . . . . . 37

Table 28. How to Identify Current and Forthcoming Products by the Process Identification Letter . . . . . 37

**REVISION HISTORY . . . . . 38**

Table 29. Document Revision History . . . . . 38

勝特力材料 886-3-5753170  
勝特力电子(上海) 86-21-54151736  
勝特力电子(深圳) 86-755-83298787  
[Http://www.100y.com.tw](http://www.100y.com.tw)

## SUMMARY DESCRIPTION

These electrically erasable programmable memory (EEPROM) devices are accessed by a high speed SPI-compatible bus. The memory array is organized as 8192 x 8 bit (M95640), and 4096 x 8 bit (M95320).

The device is accessed by a simple serial interface that is SPI-compatible. The bus signals are C, D and Q, as shown in Table 1 and Figure 2.

The device is selected when Chip Select ( $\bar{S}$ ) is taken Low. Communications with the device can be interrupted using Hold (HOLD).

Figure 2. Logic Diagram

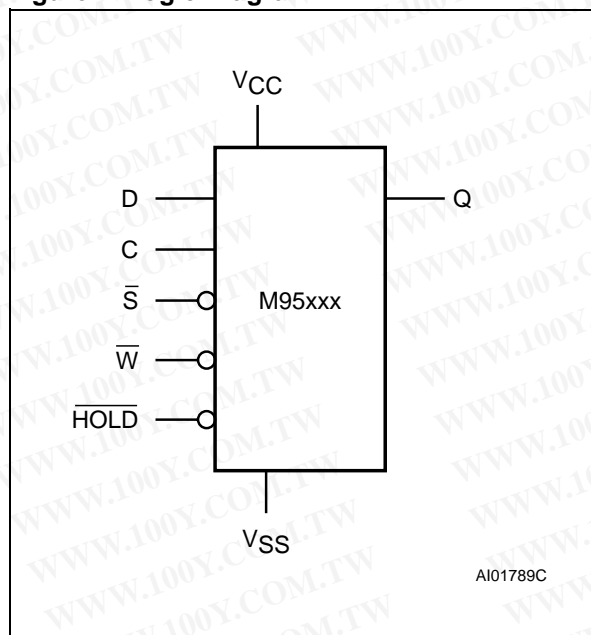
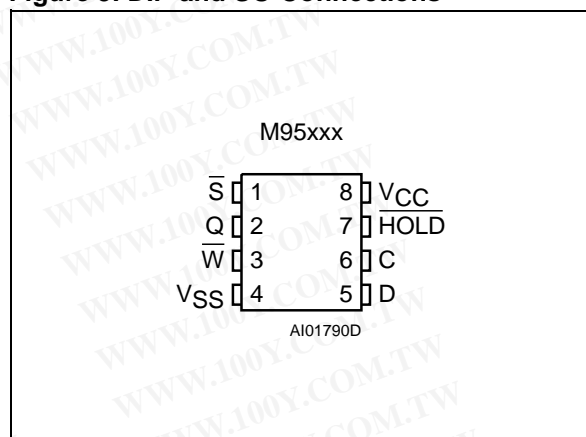
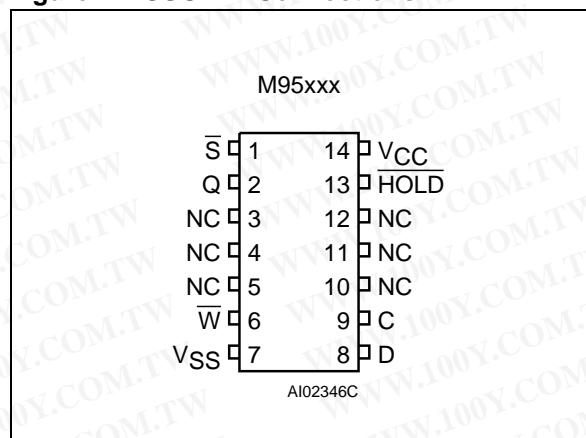

Figure 3. DIP and SO Connections



Note: 1. See page 33 (onwards) for package dimensions, and how to identify pin-1.

Figure 4. TSSOP14 Connections



Note: 1. See page 33 (onwards) for package dimensions, and how to identify pin-1.  
2. NC = Not Connected

勝特力材料 886-3-5753170  
勝特力电子(上海) 86-21-54151736  
勝特力电子(深圳) 86-755-83298787  
[Http://www.100y.com.tw](http://www.100y.com.tw)

Table 1. Signal Names

C	Serial Clock
D	Serial Data Input
Q	Serial Data Output
$\bar{S}$	Chip Select
$\bar{W}$	Write Protect
HOLD	Hold
V <sub>CC</sub>	Supply Voltage
V <sub>SS</sub>	Ground

**SIGNAL DESCRIPTION**

During all operations,  $V_{CC}$  must be held stable and within the specified valid range:  $V_{CC}(\min)$  to  $V_{CC}(\max)$ .

All of the input and output signals must be held High or Low (according to voltages of  $V_{IH}$ ,  $V_{OH}$ ,  $V_{IL}$  or  $V_{OL}$ , as specified in Tables 13 to 17). These signals are described next.

**Serial Data Output (Q).** This output signal is used to transfer data serially out of the device. Data is shifted out on the falling edge of Serial Clock (C).

**Serial Data Input (D).** This input signal is used to transfer data serially into the device. It receives instructions, addresses, and the data to be written. Values are latched on the rising edge of Serial Clock (C).

**Serial Clock (C).** This input signal provides the timing of the serial interface. Instructions, addresses, or data present at Serial Data Input (D) are latched on the rising edge of Serial Clock (C). Data on Serial Data Output (Q) changes after the falling edge of Serial Clock (C).

**Chip Select ( $\bar{S}$ ).** When this input signal is High, the device is deselected and Serial Data Output

(Q) is at high impedance. Unless an internal Write cycle is in progress, the device will be in the Standby mode. Driving Chip Select ( $\bar{S}$ ) Low enables the device, placing it in the active power mode.

After Power-up, a falling edge on Chip Select ( $\bar{S}$ ) is required prior to the start of any instruction.

**Hold ( $\overline{HOLD}$ ).** The Hold ( $\overline{HOLD}$ ) signal is used to pause any serial communications with the device without deselecting the device.

During the Hold condition, the Serial Data Output (Q) is high impedance, and Serial Data Input (D) and Serial Clock (C) are Don't Care.

To start the Hold condition, the device must be selected, with Chip Select ( $\bar{S}$ ) driven Low.

**Write Protect ( $\bar{W}$ ).** The main purpose of this input signal is to freeze the size of the area of memory that is protected against Write instructions (as specified by the values in the BP1 and BP0 bits of the Status Register).

This pin must be driven either High or Low, and must be stable during all write operations.

勝特力材料 886-3-5753170  
勝特力电子(上海) 86-21-54151736  
勝特力电子(深圳) 86-755-83298787  
[Http://www.100y.com.tw](http://www.100y.com.tw)

## CONNECTING TO THE SPI BUS

These devices are fully compatible with the SPI protocol.

All instructions, addresses and input data bytes are shifted in to the device, most significant bit first. The Serial Data Input (D) is sampled on the first rising edge of the Serial Clock (C) after Chip Select ( $\bar{S}$ ) goes Low.

All output data bytes are shifted out of the device, most significant bit first. The Serial Data Output

(Q) is latched on the first falling edge of the Serial Clock (C) after the instruction (such as the Read from Memory Array and Read Status Register instructions) have been clocked into the device.

Figure 5 shows three devices, connected to an MCU, on a SPI bus. Only one device is selected at a time, so only one device drives the Serial Data Output (Q) line at a time, all the others being high impedance.

**Figure 5. Bus Master and Memory Devices on the SPI Bus**

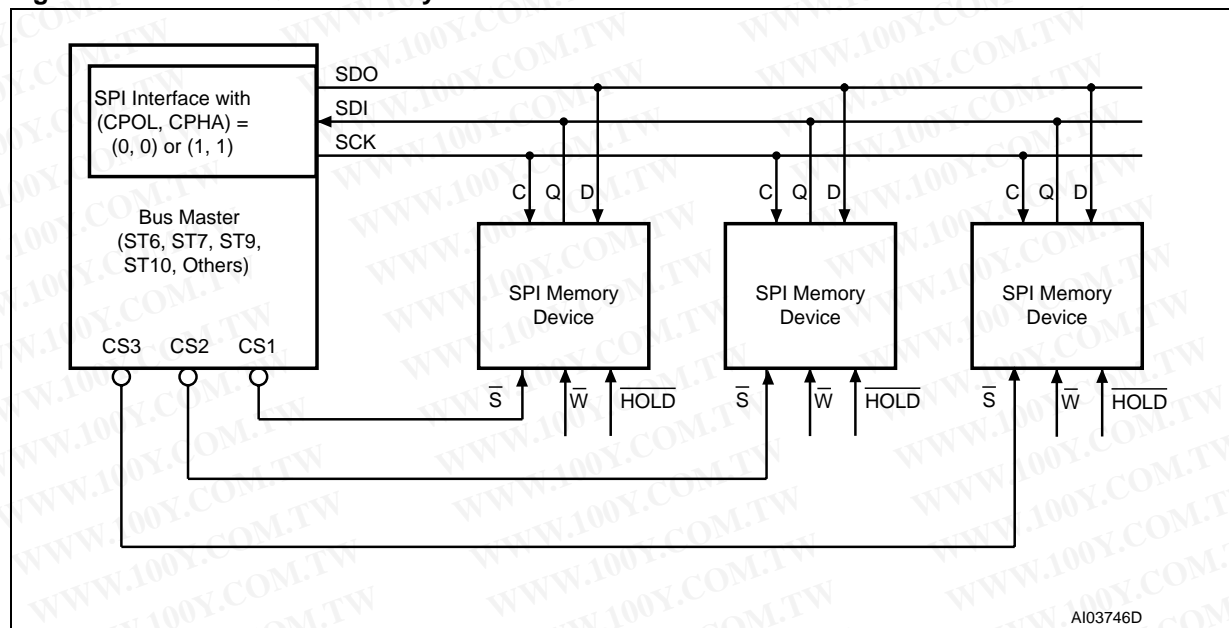

Note: 1. The Write Protect ( $\bar{W}$ ) and Hold ( $\overline{HOLD}$ ) signals should be driven, High or Low as appropriate.

### SPI Modes

These devices can be driven by a microcontroller with its SPI peripheral running in either of the two following modes:

- CPOL=0, CPHA=0
- CPOL=1, CPHA=1

For these two modes, input data is latched in on the rising edge of Serial Clock (C), and output data

is available from the falling edge of Serial Clock (C).

The difference between the two modes, as shown in Figure 6, is the clock polarity when the bus master is in Stand-by mode and not transferring data:

- C remains at 0 for (CPOL=0, CPHA=0)
- C remains at 1 for (CPOL=1, CPHA=1)

勝特力材料 886-3-5753170  
 勝特力电子(上海) 86-21-54151736  
 勝特力电子(深圳) 86-755-83298787  
[Http://www.100y.com.tw](http://www.100y.com.tw)

Figure 6. SPI Modes Supported

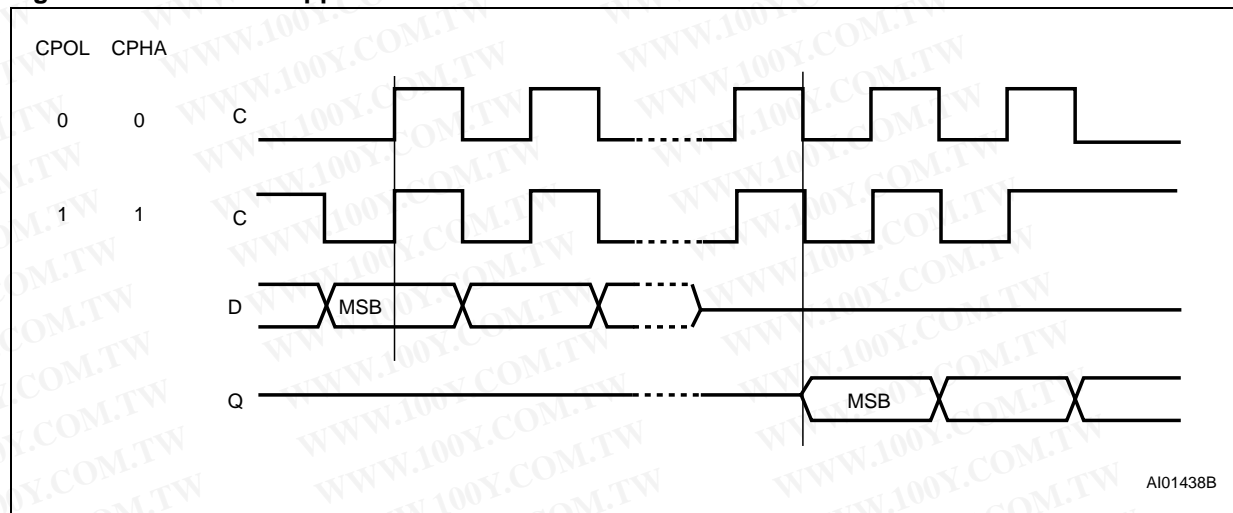

勝特力材料 886-3-5753170  
 勝特力电子(上海) 86-21-54151736  
 勝特力电子(深圳) 86-755-83298787  
[Http://www.100y.com.tw](http://www.100y.com.tw)



## OPERATING FEATURES

### Power-up

When the power supply is turned on,  $V_{CC}$  rises from  $V_{SS}$  to  $V_{CC}$ .

During this time, the Chip Select ( $\overline{S}$ ) must be allowed to follow the  $V_{CC}$  voltage. It must not be allowed to float, but should be connected to  $V_{CC}$  via a suitable pull-up resistor.

As a built in safety feature, Chip Select ( $\overline{S}$ ) is edge sensitive as well as level sensitive. After Power-up, the device does not become selected until a falling edge has first been detected on Chip Select ( $\overline{S}$ ). This ensures that Chip Select ( $\overline{S}$ ) must have been High, prior to going Low to start the first operation.

### Power On Reset: $V_{CC}$ Lock-Out Write Protect

In order to prevent data corruption and inadvertent Write operations during Power-up, a Power On Reset (POR) circuit is included. The internal reset is held active until  $V_{CC}$  has reached the POR threshold value, and all operations are disabled – the device will not respond to any command. In the same way, when  $V_{CC}$  drops from the operating voltage, below the POR threshold value, all operations are disabled and the device will not respond to any command.

A stable and valid  $V_{CC}$  must be applied before applying any logic signal.

### Power-down

At Power-down, the device must be deselected. Chip Select ( $\overline{S}$ ) should be allowed to follow the voltage applied on  $V_{CC}$ .

### Active Power and Stand-by Power Modes

When Chip Select ( $\overline{S}$ ) is Low, the device is enabled, and in the Active Power mode. The device consumes  $I_{CC}$ , as specified in Tables 13 to 17.

When Chip Select ( $\overline{S}$ ) is High, the device is disabled. If an Erase/Write cycle is not currently in progress, the device then goes in to the Stand-by Power mode, and the device consumption drops to  $I_{CC1}$ .

### Hold Condition

The Hold ( $\overline{HOLD}$ ) signal is used to pause any serial communications with the device without resetting the clocking sequence.

During the Hold condition, the Serial Data Output (Q) is high impedance, and Serial Data Input (D) and Serial Clock (C) are Don't Care.

To enter the Hold condition, the device must be selected, with Chip Select ( $\overline{S}$ ) Low.

Normally, the device is kept selected, for the whole duration of the Hold condition. Deselecting the device while it is in the Hold condition, has the effect of resetting the state of the device, and this mechanism can be used if it is required to reset any processes that had been in progress.

The Hold condition starts when the Hold ( $\overline{HOLD}$ ) signal is driven Low at the same time as Serial Clock (C) already being Low (as shown in Figure 7).

The Hold condition ends when the Hold ( $\overline{HOLD}$ ) signal is driven High at the same time as Serial Clock (C) already being Low.

Figure 7 also shows what happens if the rising and falling edges are not timed to coincide with Serial Clock (C) being Low.

Figure 7. Hold Condition Activation

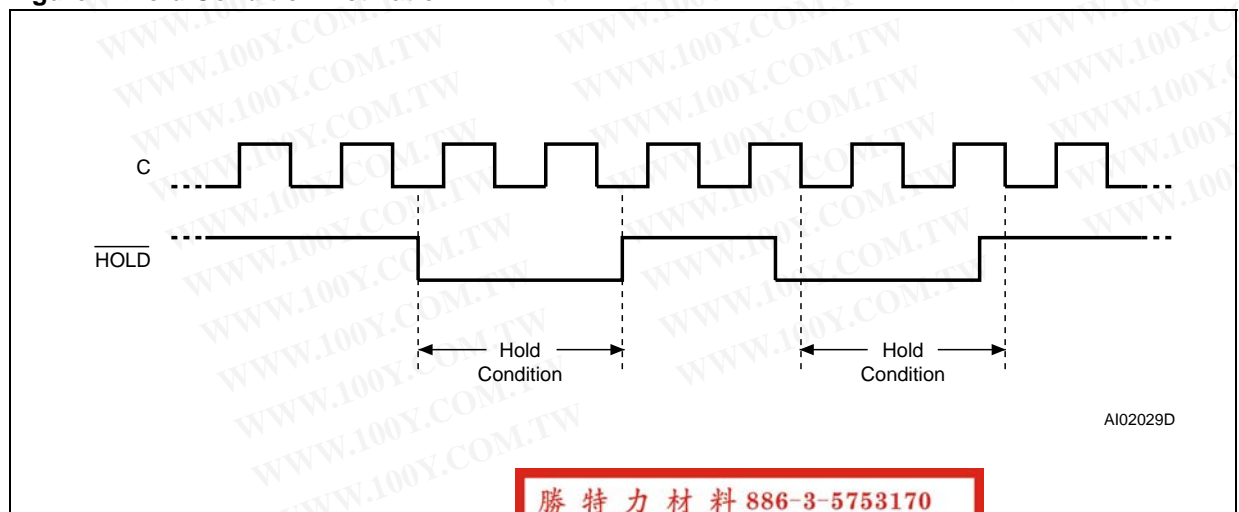

勝特力材料 886-3-5753170  
 勝特力电子(上海) 86-21-54151736  
 勝特力电子(深圳) 86-755-83298787  
[Http://www.100y.com.tw](http://www.100y.com.tw)

**Status Register**

Figure 8 shows the position of the Status Register in the control logic of the device. The Status Register contains a number of status and control bits that can be read or set (as appropriate) by specific instructions.

**WIP bit.** The Write In Progress (WIP) bit indicates whether the memory is busy with a Write or Write Status Register cycle.

**WEL bit.** The Write Enable Latch (WEL) bit indicates the status of the internal Write Enable Latch.

**BP1, BP0 bits.** The Block Protect (BP1, BP0) bits are non-volatile. They define the size of the area to be software protected against Write instructions.

**SRWD bit.** The Status Register Write Disable (SRWD) bit is operated in conjunction with the Write Protect ( $\bar{W}$ ) signal. The Status Register Write Disable (SRWD) bit and Write Protect ( $\bar{W}$ ) signal allow the device to be put in the Hardware Protected mode. In this mode, the non-volatile bits of the Status Register (SRWD, BP1, BP0) become read-only bits.

**Table 2. Status Register Format**

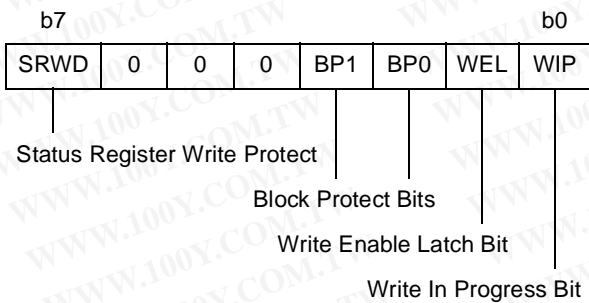

**Data Protection and Protocol Control**

Non-volatile memory devices can be used in environments that are particularly noisy, and within applications that could experience problems if memory bytes are corrupted. Consequently, the device features the following data protection mechanisms:

**Table 3. Write-Protected Block Size**

Status Register Bits		Protected Block	Array Addresses Protected	
BP1	BP0		M95640	M95320
0	0	none	none	none
0	1	Upper quarter	1800h - 1FFFh	0C00h - 0FFFh
1	0	Upper half	1000h - 1FFFh	0800h - 0FFFh
1	1	Whole memory	0000h - 1FFFh	0000h - 0FFFh

- Write and Write Status Register instructions are checked that they consist of a number of clock pulses that is a multiple of eight, before they are accepted for execution.
- All instructions that modify data must be preceded by a Write Enable (WREN) instruction to set the Write Enable Latch (WEL) bit. This bit is returned to its reset state by the following events:
  - Power-up
  - Write Disable (WRDI) instruction completion
  - Write Status Register (WRSR) instruction completion
  - Write (WRITE) instruction completion
- The Block Protect (BP1, BP0) bits allow part of the memory to be configured as read-only. This is the Software Protected Mode (SPM).
- The Write Protect ( $\bar{W}$ ) signal allows the Block Protect (BP1, BP0) bits to be protected. This is the Hardware Protected Mode (HPM).

For any instruction to be accepted, and executed, Chip Select ( $\bar{S}$ ) must be driven High after the rising edge of Serial Clock (C) for the last bit of the instruction, and before the next rising edge of Serial Clock (C).

Two points need to be noted in the previous sentence:

- The ‘last bit of the instruction’ can be the eighth bit of the instruction code, or the eighth bit of a data byte, depending on the instruction (except for Read Status Register (RDSR) and Read (READ) instructions).
- The ‘next rising edge of Serial Clock (C)’ might (or might not) be the next bus transaction for some other device on the SPI bus.

勝特力材料 886-3-5753170  
 勝特力电子(上海) 86-21-54151736  
 勝特力电子(深圳) 86-755-83298787  
[Http://www.100y.com.tw](http://www.100y.com.tw)



勝特力材料 886-3-5753170  
 勝特力电子(上海) 86-21-54151736  
 勝特力电子(深圳) 86-755-83298787  
[Http://www.100y.com.tw](http://www.100y.com.tw)

## MEMORY ORGANIZATION

The memory is organized as shown in Figure 8.

Figure 8. Block Diagram

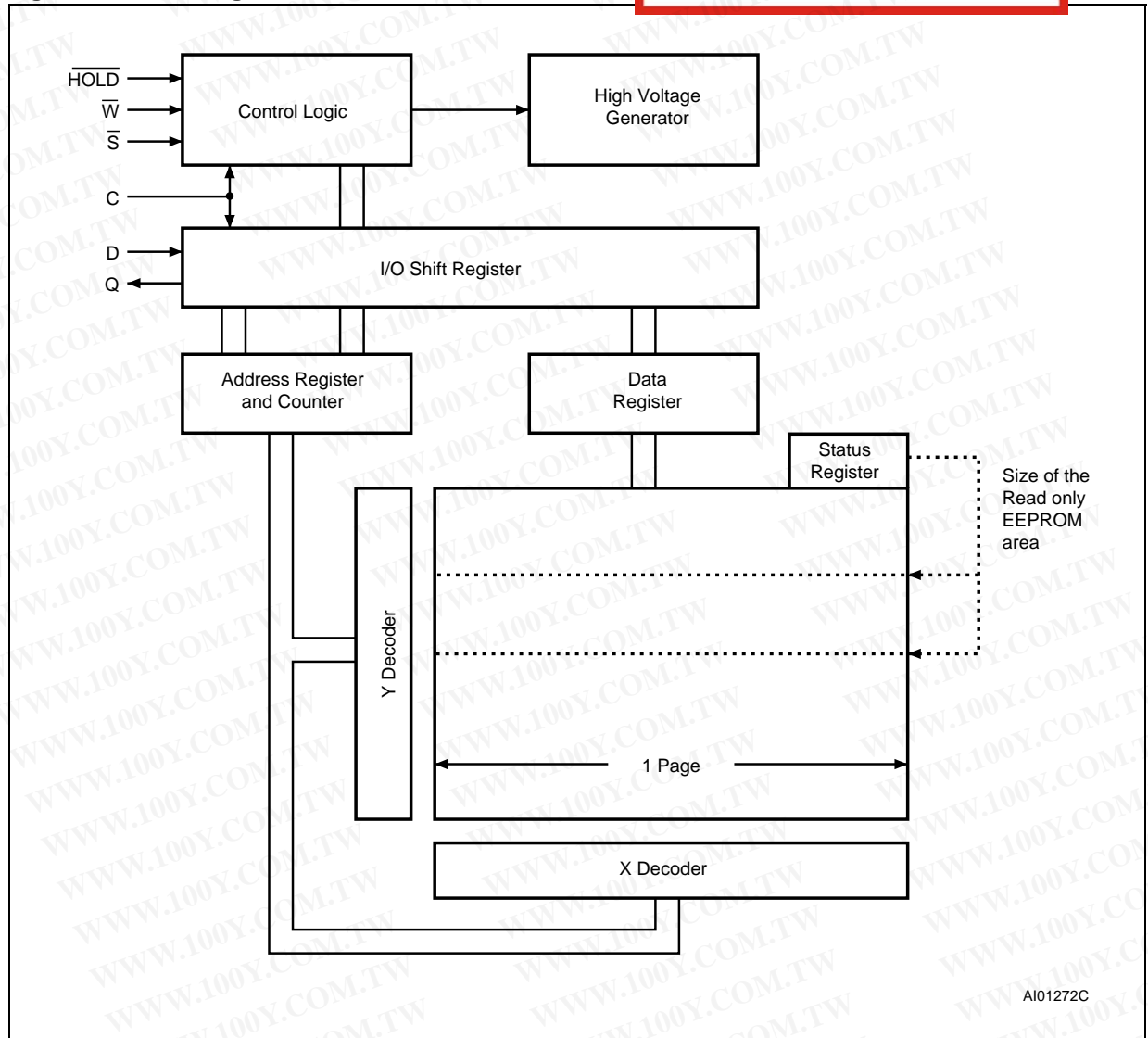

**INSTRUCTIONS**

Each instruction starts with a single-byte code, as summarized in Table 4.

If an invalid instruction is sent (one not contained in Table 4), the device automatically deselects itself.

勝特力材料 886-3-5753170  
 勝特力电子(上海) 86-21-54151736  
 勝特力电子(深圳) 86-755-83298787  
[Http://www.100y.com.tw](http://www.100y.com.tw)

**Table 4. Instruction Set**

Instruc tion	Description	Instruction Format
WREN	Write Enable	0000 0110
WRDI	Write Disable	0000 0100
RDSR	Read Status Register	0000 0101
WRSR	Write Status Register	0000 0001
READ	Read from Memory Array	0000 0011
WRITE	Write to Memory Array	0000 0010

**Figure 9. Write Enable (WREN) Sequence**

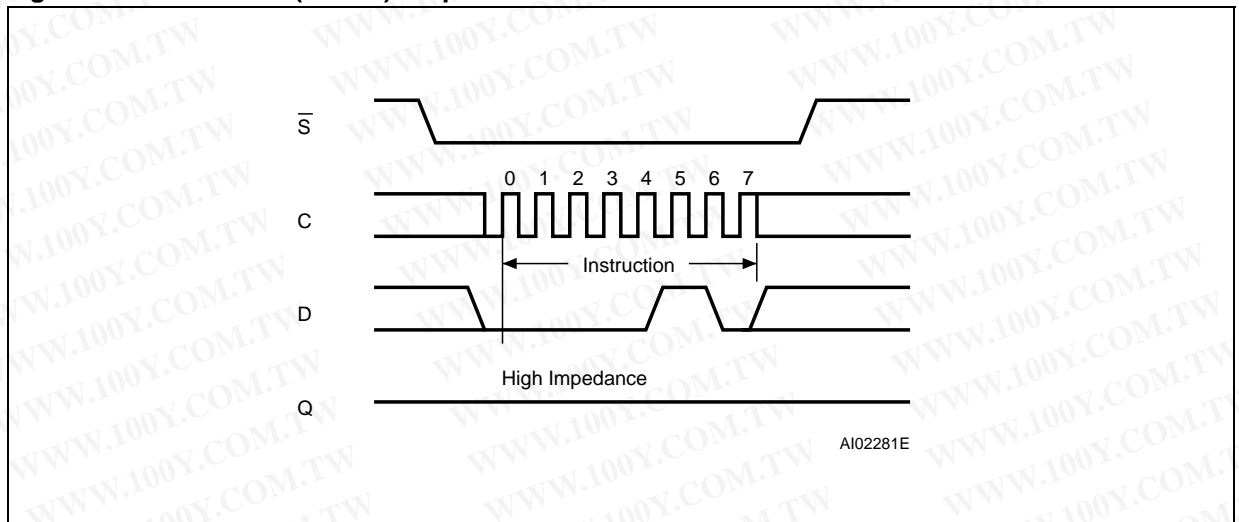

**Write Enable (WREN)**

The Write Enable Latch (WEL) bit must be set prior to each WRITE and WRSR instruction. The only way to do this is to send a Write Enable instruction to the device.

As shown in Figure 9, to send this instruction to the device, Chip Select ( $\bar{S}$ ) is driven Low, and the bits of the instruction byte are shifted in, on Serial Data Input (D). The device then enters a wait state. It waits for a the device to be deselected, by Chip Select ( $\bar{S}$ ) being driven High.

Figure 10. Write Disable (WRDI) Sequence

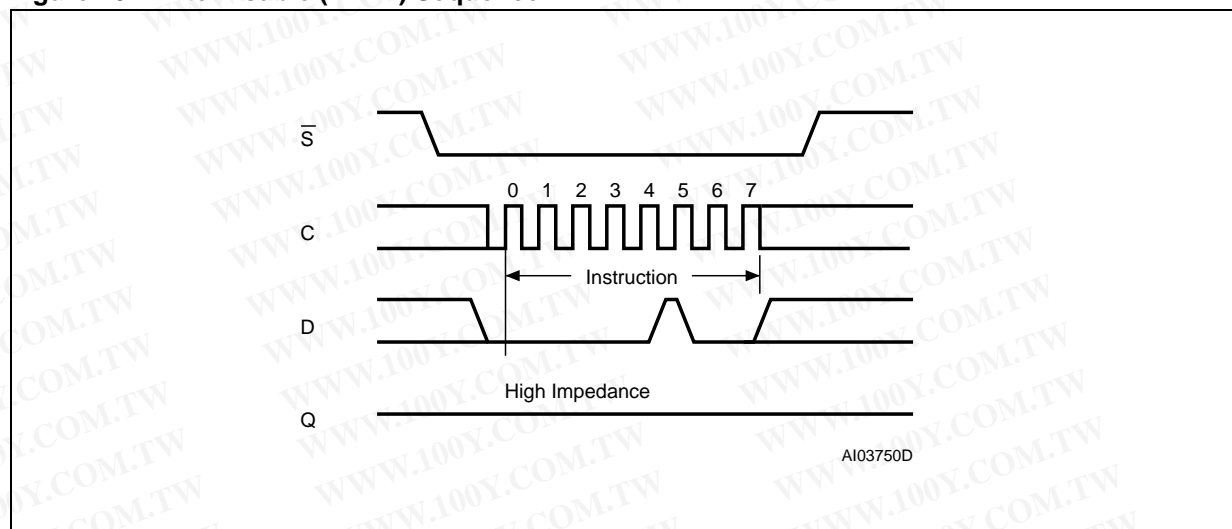

### Write Disable (WRDI)

One way of resetting the Write Enable Latch (WEL) bit is to send a Write Disable instruction to the device.

As shown in Figure 10, to send this instruction to the device, Chip Select ( $\bar{S}$ ) is driven Low, and the bits of the instruction byte are shifted in, on Serial Data Input (D).

The device then enters a wait state. It waits for a the device to be deselected, by Chip Select ( $\bar{S}$ ) being driven High.

The Write Enable Latch (WEL) bit, in fact, becomes reset by any of the following events:

- Power-up
- WRDI instruction execution
- WRSR instruction completion
- WRITE instruction completion.

勝特力材料 886-3-5753170  
 勝特力电子(上海) 86-21-54151736  
 勝特力电子(深圳) 86-755-83298787  
[Http://www.100y.com.tw](http://www.100y.com.tw)

Figure 11. Read Status Register (RDSR) Sequence

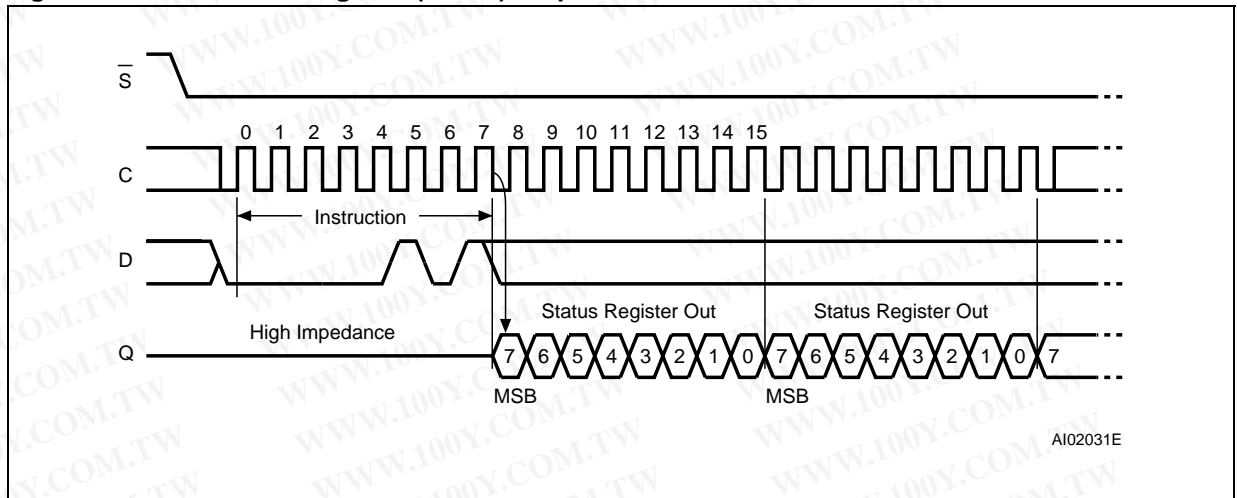

### Read Status Register (RDSR)

The Read Status Register (RDSR) instruction allows the Status Register to be read. The Status Register may be read at any time, even while a Write or Write Status Register cycle is in progress. When one of these cycles is in progress, it is recommended to check the Write In Progress (WIP) bit before sending a new instruction to the device. It is also possible to read the Status Register continuously, as shown in Figure 11.

The status and control bits of the Status Register are as follows:

**WIP bit.** The Write In Progress (WIP) bit indicates whether the memory is busy with a Write or Write Status Register cycle. When set to 1, such a cycle is in progress, when reset to 0 no such cycle is in progress.

**WEL bit.** The Write Enable Latch (WEL) bit indicates the status of the internal Write Enable Latch. When set to 1 the internal Write Enable Latch is set, when set to 0 the internal Write Enable Latch is reset and no Write or Write Status Register instruction is accepted.

**BP1, BP0 bits.** The Block Protect (BP1, BP0) bits are non-volatile. They define the size of the area to be software protected against Write instructions. These bits are written with the Write Status Register (WRSR) instruction. When one or both of the Block Protect (BP1, BP0) bits is set to 1, the relevant memory area (as defined in Table 2) becomes protected against Write (WRITE) instructions. The Block Protect (BP1, BP0) bits can be written provided that the Hardware Protected mode has not been set.

**SRWD bit.** The Status Register Write Disable (SRWD) bit is operated in conjunction with the Write Protect ( $\bar{W}$ ) signal. The Status Register Write Disable (SRWD) bit and Write Protect ( $\bar{W}$ ) signal allow the device to be put in the Hardware Protected mode (when the Status Register Write Disable (SRWD) bit is set to 1, and Write Protect ( $\bar{W}$ ) is driven Low). In this mode, the non-volatile bits of the Status Register (SRWD, BP1, BP0) become read-only bits and the Write Status Register (WRSR) instruction is no longer accepted for execution.

勝特力材料 886-3-5753170  
 勝特力电子(上海) 86-21-54151736  
 勝特力电子(深圳) 86-755-83298787  
[Http://www.100y.com.tw](http://www.100y.com.tw)

Figure 12. Write Status Register (WRSR) Sequence

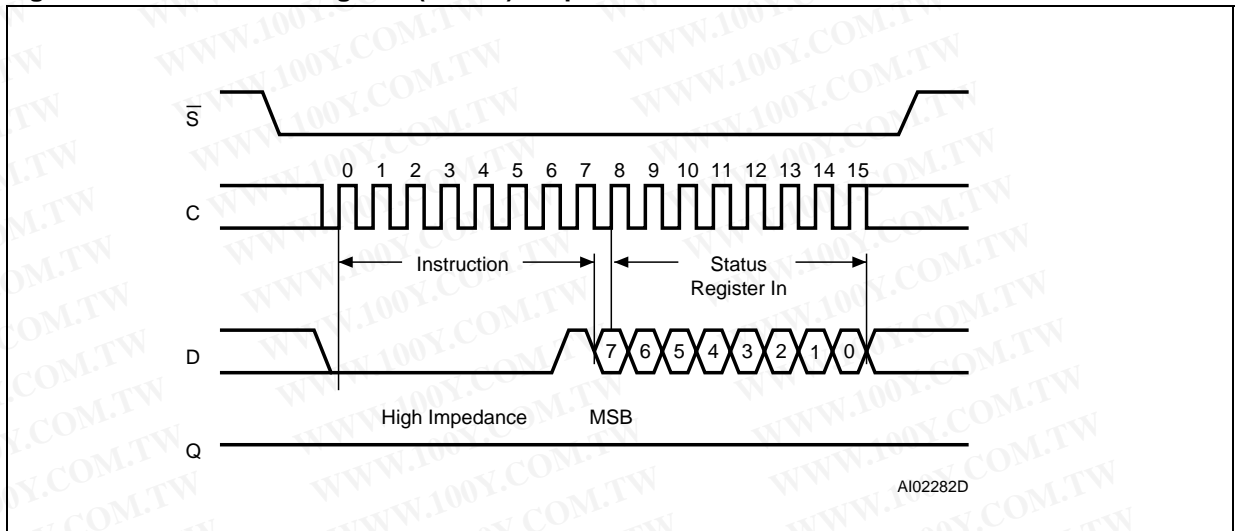

### Write Status Register (WRSR)

The Write Status Register (WRSR) instruction allows new values to be written to the Status Register. Before it can be accepted, a Write Enable (WREN) instruction must previously have been executed. After the Write Enable (WREN) instruction has been decoded and executed, the device sets the Write Enable Latch (WEL).

The Write Status Register (WRSR) instruction is entered by driving Chip Select ( $\bar{S}$ ) Low, followed by the instruction code and the data byte on Serial Data Input (D).

The instruction sequence is shown in Figure 12.

The Write Status Register (WRSR) instruction has no effect on b6, b5, b4, b1 and b0 of the Status Register. b6, b5 and b4 are always read as 0.

Chip Select ( $\bar{S}$ ) must be driven High after the rising edge of Serial Clock (C) that latches in the eighth bit of the data byte, and before the next rising edge of Serial Clock (C). Otherwise, the Write Status Register (WRSR) instruction is not executed. As soon as Chip Select ( $\bar{S}$ ) is driven High, the self-timed Write Status Register cycle (whose duration is  $t_{W}$ ) is initiated. While the Write Status Register cycle is in progress, the Status Register may still be read to check the value of the Write In Progress

(WIP) bit. The Write In Progress (WIP) bit is 1 during the self-timed Write Status Register cycle, and is 0 when it is completed. When the cycle is completed, the Write Enable Latch (WEL) is reset.

The Write Status Register (WRSR) instruction allows the user to change the values of the Block Protect (BP1, BP0) bits, to define the size of the area that is to be treated as read-only, as defined in Table 2.

The Write Status Register (WRSR) instruction also allows the user to set or reset the Status Register Write Disable (SRWD) bit in accordance with the Write Protect ( $\bar{W}$ ) signal. The Status Register Write Disable (SRWD) bit and Write Protect ( $\bar{W}$ ) signal allow the device to be put in the Hardware Protected Mode (HPM). The Write Status Register (WRSR) instruction is not executed once the Hardware Protected Mode (HPM) is entered.

The contents of the Status Register Write Disable (SRWD) and Block Protect (BP1, BP0) bits are frozen at their current values from just before the start of the execution of Write Status Register (WRSR) instruction. The new, updated, values take effect at the moment of completion of the execution of Write Status Register (WRSR) instruction.

勝特力材料 886-3-5753170  
 勝特力电子(上海) 86-21-54151736  
 勝特力电子(深圳) 86-755-83298787  
[Http://www.100y.com.tw](http://www.100y.com.tw)

Table 5. Protection Modes

$\bar{W}$ Signal	SRWD Bit	Mode	Write Protection of the Status Register	Memory Content	
				Protected Area <sup>1</sup>	Unprotected Area <sup>1</sup>
1	0	Software Protected (SPM)	Status Register is Writable (if the WREN instruction has set the WEL bit) The values in the BP1 and BP0 bits can be changed	Write Protected	Ready to accept Write instructions
0	0				
1	1				
0	1	Hardware Protected (HPM)	Status Register is Hardware write protected The values in the BP1 and BP0 bits cannot be changed	Write Protected	Ready to accept Write instructions

Note: 1. As defined by the values in the Block Protect (BP1, BP0) bits of the Status Register, as shown in Table 3.

The protection features of the device are summarized in Table 3.

When the Status Register Write Disable (SRWD) bit of the Status Register is 0 (its initial delivery state), it is possible to write to the Status Register provided that the Write Enable Latch (WEL) bit has previously been set by a Write Enable (WREN) instruction, regardless of the whether Write Protect ( $\bar{W}$ ) is driven High or Low.

When the Status Register Write Disable (SRWD) bit of the Status Register is set to 1, two cases need to be considered, depending on the state of Write Protect ( $\bar{W}$ ):

- If Write Protect ( $\bar{W}$ ) is driven High, it is possible to write to the Status Register provided that the Write Enable Latch (WEL) bit has previously been set by a Write Enable (WREN) instruction.
- If Write Protect ( $\bar{W}$ ) is driven Low, it is *not* possible to write to the Status Register *even* if the Write Enable Latch (WEL) bit has previously been set by a Write Enable (WREN) instruction. (Attempts to write to the Status Register are rejected, and are not accepted for execution). As a consequence, all the data bytes in the memory area that are software protected (SPM) by the

Block Protect (BP1, BP0) bits of the Status Register, are also hardware protected against data modification.

Regardless of the order of the two events, the Hardware Protected Mode (HPM) can be entered:

- by setting the Status Register Write Disable (SRWD) bit after driving Write Protect ( $\bar{W}$ ) Low
- or by driving Write Protect ( $\bar{W}$ ) Low after setting the Status Register Write Disable (SRWD) bit.

The only way to exit the Hardware Protected Mode (HPM) once entered is to pull Write Protect ( $\bar{W}$ ) High.

If Write Protect ( $\bar{W}$ ) is permanently tied High, the Hardware Protected Mode (HPM) can never be activated, and only the Software Protected Mode (SPM), using the Block Protect (BP1, BP0) bits of the Status Register, can be used.

Table 6. Address Range Bits

Device	M95640	M95320
Address Bits	A12-A0	A11-A0

Note: 1. b15 to b13 are Don't Care on the M95640.  
b15 to b12 are Don't Care on the M95320.

**勝特力材料 886-3-5753170**  
**勝特力电子(上海) 86-21-54151736**  
**勝特力电子(深圳) 86-755-83298787**  
[Http://www.100y.com.tw](http://www.100y.com.tw)



Figure 13. Read from Memory Array (READ) Sequence

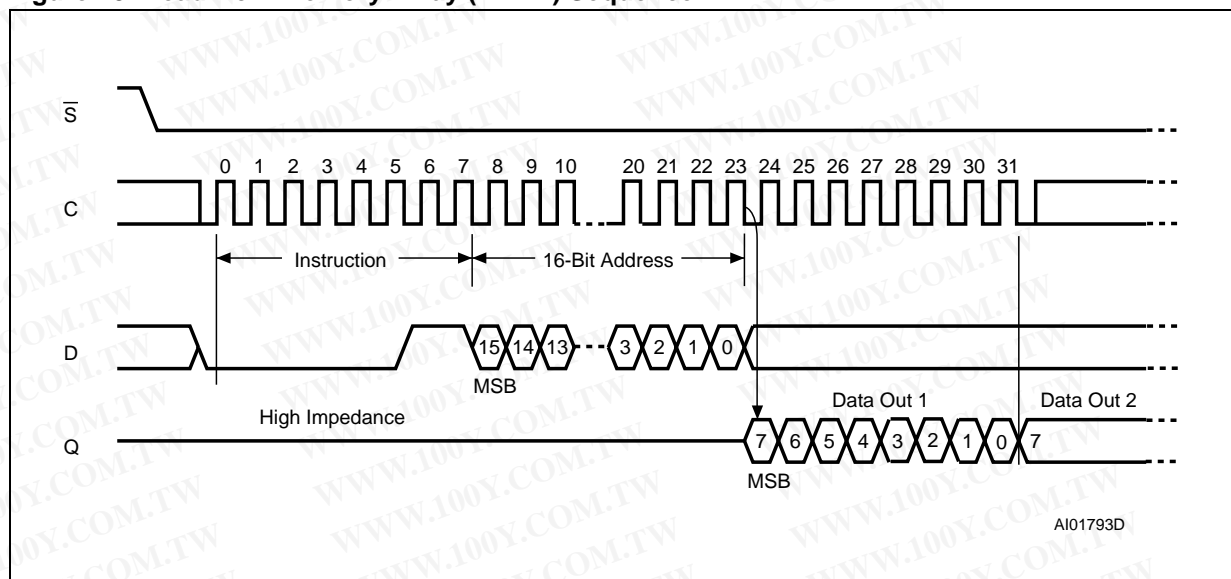

Note: Depending on the memory size, as shown in Table 6, the most significant address bits are Don't Care.

### Read from Memory Array (READ)

As shown in Figure 13, to send this instruction to the device, Chip Select ( $\bar{S}$ ) is first driven Low. The bits of the instruction byte and address bytes are then shifted in, on Serial Data Input (D). The address is loaded into an internal address register, and the byte of data at that address is shifted out, on Serial Data Output (Q).

If Chip Select ( $\bar{S}$ ) continues to be driven Low, the internal address register is automatically incremented, and the byte of data at the new address is shifted out.

When the highest address is reached, the address counter rolls over to zero, allowing the Read cycle to be continued indefinitely. The whole memory can, therefore, be read with a single READ instruction.

The Read cycle is terminated by driving Chip Select ( $\bar{S}$ ) High. The rising edge of the Chip Select ( $\bar{S}$ ) signal can occur at any time during the cycle.

The first byte addressed can be any byte within any page.

The instruction is not accepted, and is not executed, if a Write cycle is currently in progress.

勝特力材料 886-3-5753170  
 勝特力电子(上海) 86-21-54151736  
 勝特力电子(深圳) 86-755-83298787  
[Http://www.100y.com.tw](http://www.100y.com.tw)

Figure 14. Byte Write (WRITE) Sequence

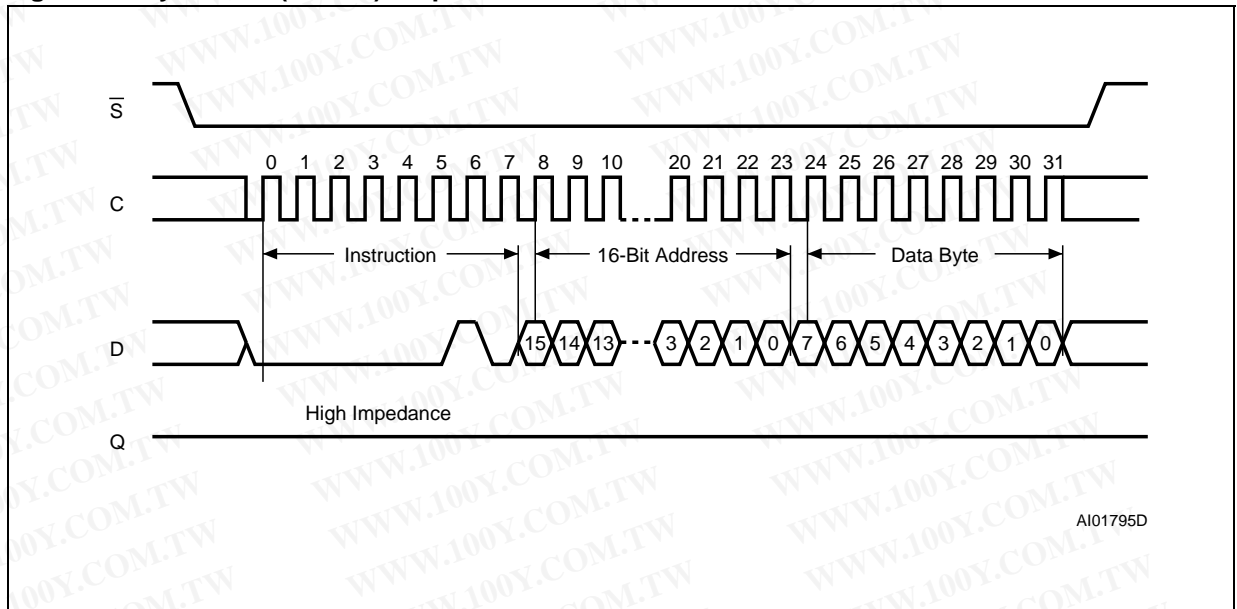

Note: Depending on the memory size, as shown in Table 6, the most significant address bits are Don't Care.

### Write to Memory Array (WRITE)

As shown in Figure 14, to send this instruction to the device, Chip Select ( $\bar{S}$ ) is first driven Low. The bits of the instruction byte, address byte, and at least one data byte are then shifted in, on Serial Data Input (D).

The instruction is terminated by driving Chip Select ( $\bar{S}$ ) High at a byte boundary of the input data. In the case of Figure 14, this occurs after the eighth bit of the data byte has been latched in, indicating that the instruction is being used to write a single byte. The self-timed Write cycle starts, and continues for a period  $t_{WC}$  (as specified in Tables 18 to 22), at the end of which the Write in Progress (WIP) bit is reset to 0.

If, though, Chip Select ( $\bar{S}$ ) continues to be driven Low, as shown in Figure 15, the next byte of input data is shifted in, so that more than a single byte, starting from the given address towards the end of the same page, can be written in a single internal Write cycle.

Each time a new data byte is shifted in, the least significant bits of the internal address counter are incremented. If the number of data bytes sent to the device exceeds the page boundary, the internal address counter rolls over to the beginning of the page, and the previous data there are overwritten with the incoming data. (The page size of these devices is 32 bytes).

The instruction is not accepted, and is not executed, under the following conditions:

- if the Write Enable Latch (WEL) bit has not been set to 1 (by executing a Write Enable instruction just before)
- if a Write cycle is already in progress
- if the device has not been deselected, by Chip Select ( $\bar{S}$ ) being driven High, at a byte boundary (after the eighth bit, b0, of the last data byte that has been latched in)
- if the addressed page is in the region protected by the Block Protect (BP1 and BP0) bits.

勝特力材料 886-3-5753170  
 勝特力电子(上海) 86-21-54151736  
 勝特力电子(深圳) 86-755-83298787  
[Http://www.100y.com.tw](http://www.100y.com.tw)

Figure 15. Page Write (WRITE) Sequence

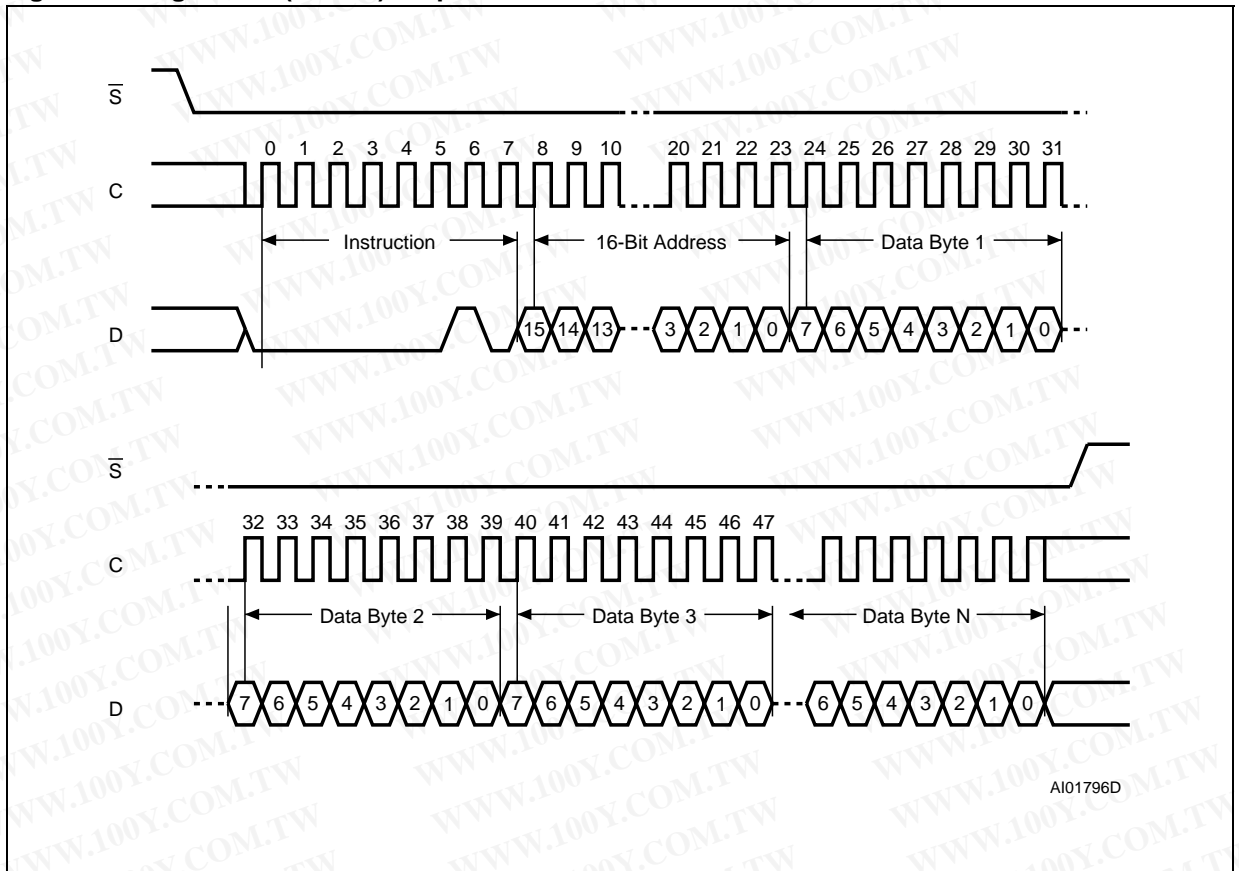

Note: Depending on the memory size, as shown in Table 6, the most significant address bits are Don't Care.

勝特力材料 886-3-5753170  
 勝特力电子(上海) 86-21-54151736  
 勝特力电子(深圳) 86-755-83298787  
[Http://www.100y.com.tw](http://www.100y.com.tw)

## POWER-UP AND DELIVERY STATE

### Power-up State

After Power-up, the device is in the following state:

- Stand-by mode
- deselected (after Power-up, a falling edge is required on Chip Select ( $\bar{S}$ ) before any instructions can be started).
- not in the Hold Condition
- the Write Enable Latch (WEL) is reset to 0
- Write In Progress (WIP) is reset to 0

the SRWD, BP1 and BP0 bits of the Status Register are unchanged from the previous power-down (they are non-volatile bits).

### INITIAL DELIVERY STATE

The device is delivered with the memory array set at all 1s (FFh). The Status Register Write Disable (SRWD) and Block Protect (BP1 and BP0) bits are initialized to 0.

勝特力材料 886-3-5753170  
勝特力电子(上海) 86-21-54151736  
勝特力电子(深圳) 86-755-83298787  
[Http://www.100y.com.tw](http://www.100y.com.tw)

**MAXIMUM RATING**

Stressing the device above the rating listed in the Absolute Maximum Ratings" table may cause permanent damage to the device. These are stress ratings only and operation of the device at these or any other conditions above those indicated in the Operating sections of this specification is not im-

plied. Exposure to Absolute Maximum Rating conditions for extended periods may affect device reliability. Refer also to the STMicroelectronics SURE Program and other relevant quality documents.

**Table 7. Absolute Maximum Ratings**

Symbol	Parameter	Min.	Max.	Unit
T <sub>STG</sub>	Storage Temperature	-65	150	°C
T <sub>LEAD</sub>	Lead Temperature during Soldering <sup>1</sup>		260 <sup>2</sup> 260 <sup>3</sup> 260 <sup>3</sup>	°C
V <sub>O</sub>	Output Voltage	-0.45	V <sub>CC</sub> +0.6	V
V <sub>I</sub>	Input Voltage	-0.45	6.5	V
V <sub>CC</sub>	Supply Voltage	-0.3	6.5	V
V <sub>ESD</sub>	Electrostatic Discharge Voltage (Human Body model) <sup>4</sup>	-4000	4000	V

Note: 1. Compliant with the ECOPACK® 7191395 specification for lead-free soldering processes  
 2. No longer than 10 seconds  
 3. Not exceeding 250°C for more than 30 seconds, and peaking at 260°C  
 4. JEDEC Std JESD22-A114A (C1=100 pF, R1=1500 Ω, R2=500 Ω)

勝特力材料 886-3-5753170  
 勝特力电子(上海) 86-21-54151736  
 勝特力电子(深圳) 86-755-83298787  
[Http://www.100y.com.tw](http://www.100y.com.tw)

**DC AND AC PARAMETERS**

This section summarizes the operating and measurement conditions, and the DC and AC characteristics of the device. The parameters in the DC and AC Characteristic tables that follow are derived from tests performed under the Measure-

ment Conditions summarized in the relevant tables. Designers should check that the operating conditions in their circuit match the measurement conditions when relying on the quoted parameters.

**Table 8. Operating Conditions (M95xxx)**

Symbol	Parameter	Min.	Max.	Unit
V <sub>CC</sub>	Supply Voltage	4.5	5.5	V
T <sub>A</sub>	Ambient Operating Temperature (range 6)	-40	85	°C
	Ambient Operating Temperature (range 3)	-40	125	°C

**Table 9. Operating Conditions (M95xxx-W)**

Symbol	Parameter	Min.	Max.	Unit
V <sub>CC</sub>	Supply Voltage	2.5	5.5	V
T <sub>A</sub>	Ambient Operating Temperature (range 6)	-40	85	°C
	Ambient Operating Temperature (range 3)	-40	125	°C

**Table 10. Operating Conditions (M95xxx-R)**

Symbol	Parameter <sup>1</sup>	Min.	Max.	Unit
V <sub>CC</sub>	Supply Voltage	1.8	5.5	V
T <sub>A</sub>	Ambient Operating Temperature	-40	85	°C

Note: 1. This product is under development. For more information, please contact your nearest ST sales office.

**Table 11. AC Measurement Conditions**

Symbol	Parameter	Min.	Max.	Unit
C <sub>L</sub>	Load Capacitance	100		pF
	Input Rise and Fall Times		50	ns
	Input Pulse Voltages	0.2V <sub>CC</sub> to 0.8V <sub>CC</sub>		V
	Input and Output Timing Reference Voltages	0.3V <sub>CC</sub> to 0.7V <sub>CC</sub>		V

Note: 1. Output Hi-Z is defined as the point where data out is no longer driven.

**Figure 16. AC Measurement I/O Waveform**

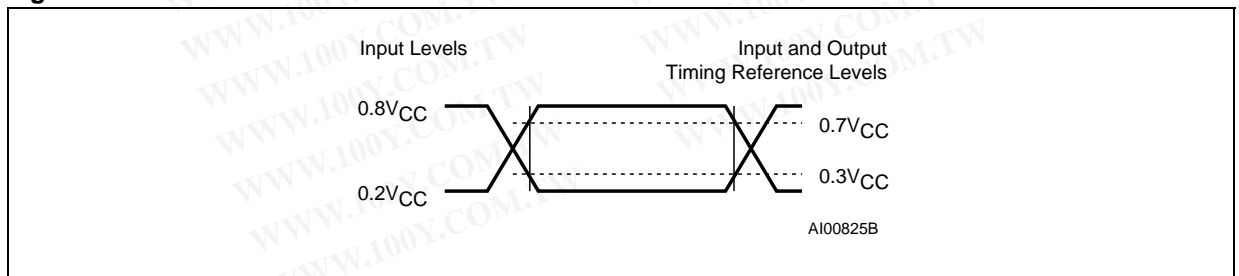

Table 12. Capacitance

Symbol	Parameter	Test Condition	Min.	Max.	Unit
$C_{OUT}$	Output Capacitance (Q)	$V_{OUT} = 0V$		8	pF
$C_{IN}$	Input Capacitance (D)	$V_{IN} = 0V$		8	pF
	Input Capacitance (other pins)	$V_{IN} = 0V$		6	pF

Note: Sampled only, not 100% tested, at  $T_A=25^\circ C$  and a frequency of 5 MHz.

Table 13. DC Characteristics (M95xxx, temperature range 6)

Symbol	Parameter	Test Condition	Min.	Max.	Unit
$I_{LI}$	Input Leakage Current	$V_{IN} = V_{SS}$ or $V_{CC}$		$\pm 2$	$\mu A$
$I_{LO}$	Output Leakage Current	$\bar{S} = V_{CC}$ , $V_{OUT} = V_{SS}$ or $V_{CC}$		$\pm 2$	$\mu A$
$I_{CC}$	Supply Current	$C = 0.1V_{CC}/0.9V_{CC}$ at 5MHz, $V_{CC} = 5V$ , Q = open, Current Product <sup>2</sup>		4	mA
		$C = 0.1V_{CC}/0.9V_{CC}$ at 10MHz, $V_{CC} = 5V$ , Q = open, New Product <sup>3</sup>		5	mA
$I_{CC1}$	Supply Current (Stand-by)	$\bar{S} = V_{CC}$ , $V_{CC} = 5V$ , $V_{IN} = V_{SS}$ or $V_{CC}$ , Current Product <sup>2</sup>		10	$\mu A$
		$\bar{S} = V_{CC}$ , $V_{CC} = 5V$ , $V_{IN} = V_{SS}$ or $V_{CC}$ , New Product <sup>3</sup>		2	$\mu A$
$V_{IL}$	Input Low Voltage		-0.45	$0.3 V_{CC}$	V
$V_{IH}$	Input High Voltage		$0.7 V_{CC}$	$V_{CC}+1$	V
$V_{OL}^1$	Output Low Voltage	$I_{OL} = 2mA$ , $V_{CC} = 5V$		0.4	V
$V_{OH}^1$	Output High Voltage	$I_{OH} = -2mA$ , $V_{CC} = 5V$	$0.8 V_{CC}$		V

Note: 1. For all 5V range devices, the device meets the output requirements for both TTL and CMOS standards.

2. Current product: identified by Process Identification letter S.

3. New product: identified by Process Identification letter V.

勝特力材料 886-3-5753170  
 勝特力电子(上海) 86-21-54151736  
 勝特力电子(深圳) 86-755-83298787  
[Http://www.100y.com.tw](http://www.100y.com.tw)

Table 14. DC Characteristics (M95xxx, temperature range 3)

Symbol	Parameter	Test Condition	Min.	Max.	Unit
$I_{LI}$	Input Leakage Current	$V_{IN} = V_{SS}$ or $V_{CC}$		$\pm 2$	$\mu A$
$I_{LO}$	Output Leakage Current	$\bar{S} = V_{CC}, V_{OUT} = V_{SS}$ or $V_{CC}$		$\pm 2$	$\mu A$
$I_{CC}$	Supply Current	$C = 0.1V_{CC}/0.9V_{CC}$ at 2 MHz, $V_{CC} = 5 V, Q = \text{open}, \text{Current Product}^2$		2	mA
		$C = 0.1V_{CC}/0.9V_{CC}$ at 5 MHz, $V_{CC} = 5 V, Q = \text{open}, \text{New Product}^3$		4	mA
$I_{CC1}$	Supply Current (Stand-by)	$\bar{S} = V_{CC}, V_{CC} = 5 V,$ $V_{IN} = V_{SS}$ or $V_{CC}, \text{Current Product}^2$		20	$\mu A$
		$\bar{S} = V_{CC}, V_{CC} = 5 V,$ $V_{IN} = V_{SS}$ or $V_{CC}, \text{New Product}^3$		5	$\mu A$
$V_{IL}$	Input Low Voltage		-0.45	$0.3 V_{CC}$	V
$V_{IH}$	Input High Voltage		$0.7 V_{CC}$	$V_{CC}+1$	V
$V_{OL}^1$	Output Low Voltage	$I_{OL} = 2 \text{ mA}, V_{CC} = 5 V$		0.4	V
$V_{OH}^1$	Output High Voltage	$I_{OH} = -2 \text{ mA}, V_{CC} = 5 V$	$0.8 V_{CC}$		V

Note: 1. For all 5V range devices, the device meets the output requirements for both TTL and CMOS standards.

2. Current product: identified by Process Identification letter S.

3. New product: identified by Process Identification letter B.

Table 15. DC Characteristics (M95xxx-W, temperature range 6)

Symbol	Parameter	Test Condition	Min.	Max.	Unit
$I_{LI}$	Input Leakage Current	$V_{IN} = V_{SS}$ or $V_{CC}$		$\pm 2$	$\mu A$
$I_{LO}$	Output Leakage Current	$\bar{S} = V_{CC}, V_{OUT} = V_{SS}$ or $V_{CC}$		$\pm 2$	$\mu A$
$I_{CC}$	Supply Current	$C = 0.1V_{CC}/0.9V_{CC}$ at 2 MHz, $V_{CC} = 2.5 V, Q = \text{open}, \text{Current Product}^1$		2	mA
		$C = 0.1V_{CC}/0.9V_{CC}$ at 5 MHz, $V_{CC} = 2.5 V, Q = \text{open}, \text{New Product}^2$		3	mA
$I_{CC1}$	Supply Current (Stand-by)	$\bar{S} = V_{CC}, V_{CC} = 2.5 V,$ $V_{IN} = V_{SS}$ or $V_{CC}, \text{Current Product}^1$		2	$\mu A$
		$\bar{S} = V_{CC}, V_{CC} = 2.5 V$ $V_{IN} = V_{SS}$ or $V_{CC}, \text{New Product}^2$		1	$\mu A$
$V_{IL}$	Input Low Voltage		-0.45	$0.3 V_{CC}$	V
$V_{IH}$	Input High Voltage		$0.7 V_{CC}$	$V_{CC}+1$	V
$V_{OL}$	Output Low Voltage	$I_{OL} = 1.5 \text{ mA}, V_{CC} = 2.5 V$		0.4	V
$V_{OH}$	Output High Voltage	$I_{OH} = -0.4 \text{ mA}, V_{CC} = 2.5 V$	$0.8 V_{CC}$		V

Note: 1. Current product: identified by Process Identification letter S.

2. New product: identified by Process Identification letter V.

勝特力材料 886-3-5753170  
 勝特力电子(上海) 86-21-54151736  
 勝特力电子(深圳) 86-755-83298787  
[Http://www.100y.com.tw](http://www.100y.com.tw)



Table 16. DC Characteristics (M95xxx-W, temperature range 3)

Symbol	Parameter	Test Condition	Min.	Max.	Unit
$I_{LI}$	Input Leakage Current	$V_{IN} = V_{SS}$ or $V_{CC}$		$\pm 2$	$\mu A$
$I_{LO}$	Output Leakage Current	$\bar{S} = V_{CC}, V_{OUT} = V_{SS}$ or $V_{CC}$		$\pm 2$	$\mu A$
$I_{CC}$	Supply Current	$C = 0.1V_{CC}/0.9V_{CC}$ at 5 MHz, $V_{CC} = 2.5 V, Q = \text{open}$		3	mA
$I_{CC1}$	Supply Current (Stand-by)	$\bar{S} = V_{CC}, V_{CC} = 2.5 V, V_{IN} = V_{SS}$ or $V_{CC}$		2	$\mu A$
$V_{IL}$	Input Low Voltage		-0.45	$0.3 V_{CC}$	V
$V_{IH}$	Input High Voltage		$0.7 V_{CC}$	$V_{CC}+1$	V
$V_{OL}$	Output Low Voltage	$I_{OL} = 1.5 \text{ mA}, V_{CC} = 2.5 V$		0.4	V
$V_{OH}$	Output High Voltage	$I_{OH} = -0.4 \text{ mA}, V_{CC} = 2.5 V$	$0.8 V_{CC}$		V

Note: New product: identified by Process Identification letter B.

Table 17. DC Characteristics (M95xxx-R)

Symbol	Parameter	Test Condition <sup>1</sup>	Min. <sup>2</sup>	Max. <sup>2</sup>	Unit
$I_{LI}$	Input Leakage Current	$V_{IN} = V_{SS}$ or $V_{CC}$		$\pm 2$	$\mu A$
$I_{LO}$	Output Leakage Current	$\bar{S} = V_{CC}, V_{OUT} = V_{SS}$ or $V_{CC}$		$\pm 2$	$\mu A$
$I_{CC}$	Supply Current	$C = 0.1V_{CC}/0.9V_{CC}$ at 2 MHz, $V_{CC} = 1.8 V, Q = \text{open}$		1	mA
$I_{CC1}$	Supply Current (Stand-by)	$\bar{S} = V_{CC}, V_{IN} = V_{SS}$ or $V_{CC}, V_{CC} = 1.8 V$		1	$\mu A$
$V_{IL}$	Input Low Voltage		-0.45	$0.3 V_{CC}$	V
$V_{IH}$	Input High Voltage		$0.7 V_{CC}$	$V_{CC}+1$	V
$V_{OL}$	Output Low Voltage	$I_{OL} = 0.15 \text{ mA}, V_{CC} = 1.8 V$		0.3	V
$V_{OH}$	Output High Voltage	$I_{OH} = -0.1 \text{ mA}, V_{CC} = 1.8 V$	$0.8 V_{CC}$		V

Note: 1. This product is under qualification. For more information, please contact your nearest ST sales office.

2. Preliminary data.

勝特力材料 886-3-5753170  
 勝特力电子(上海) 86-21-54151736  
 勝特力电子(深圳) 86-755-83298787  
[Http://www.100y.com.tw](http://www.100y.com.tw)

Table 18. AC Characteristics (M95xxx, temperature range 6)

Test conditions specified in Table 11 and Table 8							
Symbol	Alt.	Parameter	Min. <sup>3</sup>	Max. <sup>3</sup>	Min. <sup>4</sup>	Max. <sup>4</sup>	Unit
f <sub>C</sub>	f <sub>SCK</sub>	Clock Frequency	D.C.	5	D.C.	10	MHz
t <sub>SLCH</sub>	t <sub>CS1</sub>	$\overline{S}$ Active Setup Time	90		15		ns
t <sub>SHCH</sub>	t <sub>CS2</sub>	$\overline{S}$ Not Active Setup Time	90		15		ns
t <sub>SHSL</sub>	t <sub>CS</sub>	$\overline{S}$ Deselect Time	100		40		ns
t <sub>CHSH</sub>	t <sub>CSH</sub>	$\overline{S}$ Active Hold Time	90		25		ns
t <sub>CHSL</sub>		$\overline{S}$ Not Active Hold Time	90		15		ns
t <sub>CH</sub> <sup>1</sup>	t <sub>CLH</sub>	Clock High Time	90		40		ns
t <sub>CL</sub> <sup>1</sup>	t <sub>CLL</sub>	Clock Low Time	90		40		ns
t <sub>CLCH</sub> <sup>2</sup>	t <sub>RC</sub>	Clock Rise Time		1		1	μs
t <sub>CHCL</sub> <sup>2</sup>	t <sub>FC</sub>	Clock Fall Time		1		1	μs
t <sub>DVCH</sub>	t <sub>DSU</sub>	Data In Setup Time	20		15		ns
t <sub>CHDX</sub>	t <sub>DH</sub>	Data In Hold Time	30		15		ns
t <sub>HHCH</sub>		Clock Low Hold Time after $\overline{HOLD}$ not Active	70		15		ns
t <sub>HLCH</sub>		Clock Low Hold Time after $\overline{HOLD}$ Active	40		20		ns
t <sub>CHHL</sub>		Clock High Set-up Time before $\overline{HOLD}$ Active	60		30		ns
t <sub>CHHH</sub>		Clock High Set-up Time before $\overline{HOLD}$ not Active	60		30		ns
t <sub>SHQZ</sub> <sup>2</sup>	t <sub>DIS</sub>	Output Disable Time		100		25	ns
t <sub>CLQV</sub>	t <sub>V</sub>	Clock Low to Output Valid		60		25	ns
t <sub>CLQX</sub>	t <sub>HO</sub>	Output Hold Time	0		0		ns
t <sub>QLQH</sub> <sup>2</sup>	t <sub>RO</sub>	Output Rise Time		50		20	ns
t <sub>QHQL</sub> <sup>2</sup>	t <sub>FO</sub>	Output Fall Time		50		20	ns
t <sub>HHQX</sub> <sup>2</sup>	t <sub>LZ</sub>	$\overline{HOLD}$ High to Output Low-Z		50		25	ns
t <sub>HLQZ</sub> <sup>2</sup>	t <sub>HZ</sub>	$\overline{HOLD}$ Low to Output High-Z		100		25	ns
t <sub>W</sub>	t <sub>WC</sub>	Write Time		10		5	ms

Note: 1. t<sub>CH</sub> + t<sub>CL</sub> ≥ 1/f<sub>C</sub>.

2. Value guaranteed by characterization, not 100% tested in production.

3. Current product: identified by Process Identification letter S.

4. New product: identified by Process Identification letter V.

勝特力材料 886-3-5753170  
 勝特力电子(上海) 86-21-54151736  
 勝特力电子(深圳) 86-755-83298787  
[Http://www.100y.com.tw](http://www.100y.com.tw)

Table 19. AC Characteristics (M95xxx, temperature range 3)

Test conditions specified in Table 11 and Table 8							
Symbol	Alt.	Parameter	Min. <sup>3</sup>	Max. <sup>3</sup>	Min. <sup>4</sup>	Max. <sup>4</sup>	Unit
f <sub>C</sub>	f <sub>SCK</sub>	Clock Frequency	D.C.	2	D.C.	5	MHz
t <sub>SLCH</sub>	t <sub>CSS1</sub>	$\overline{S}$ Active Setup Time	200		90		ns
t <sub>SHCH</sub>	t <sub>CSS2</sub>	$\overline{S}$ Not Active Setup Time	200		90		ns
t <sub>SHSL</sub>	t <sub>CS</sub>	$\overline{S}$ Deselect Time	200		100		ns
t <sub>CHSH</sub>	t <sub>CSH</sub>	$\overline{S}$ Active Hold Time	200		90		ns
t <sub>CHSL</sub>		$\overline{S}$ Not Active Hold Time	200		90		ns
t <sub>CH</sub> <sup>1</sup>	t <sub>CLH</sub>	Clock High Time	200		90		ns
t <sub>CL</sub> <sup>1</sup>	t <sub>CLL</sub>	Clock Low Time	200		90		ns
t <sub>CLCH</sub> <sup>2</sup>	t <sub>RC</sub>	Clock Rise Time		1		1	μs
t <sub>CHCL</sub> <sup>2</sup>	t <sub>FC</sub>	Clock Fall Time		1		1	μs
t <sub>DVCH</sub>	t <sub>DSU</sub>	Data In Setup Time	40		20		ns
t <sub>CHDX</sub>	t <sub>DH</sub>	Data In Hold Time	50		30		ns
t <sub>HHCH</sub>		Clock Low Hold Time after $\overline{HOLD}$ not Active	140		70		ns
t <sub>HLCH</sub>		Clock Low Hold Time after $\overline{HOLD}$ Active	90		40		ns
t <sub>CHHL</sub>		Clock High Set-up Time before $\overline{HOLD}$ Active	120		70		ns
t <sub>CHHH</sub>		Clock High Set-up Time before $\overline{HOLD}$ not Active	120		70		ns
t <sub>SHQZ</sub> <sup>2</sup>	t <sub>DIS</sub>	Output Disable Time		250		100	ns
t <sub>CLQV</sub>	t <sub>V</sub>	Clock Low to Output Valid		150		60	ns
t <sub>CLQX</sub>	t <sub>HO</sub>	Output Hold Time	0		0		ns
t <sub>QLQH</sub> <sup>2</sup>	t <sub>RO</sub>	Output Rise Time		100		50	ns
t <sub>QHQL</sub> <sup>2</sup>	t <sub>FO</sub>	Output Fall Time		100		50	ns
t <sub>HHQX</sub> <sup>2</sup>	t <sub>LZ</sub>	$\overline{HOLD}$ High to Output Low-Z		100		50	ns
t <sub>HLQZ</sub> <sup>2</sup>	t <sub>HZ</sub>	$\overline{HOLD}$ Low to Output High-Z		250		100	ns
t <sub>w</sub>	t <sub>wc</sub>	Write Time		10		5	ms

Note: 1. t<sub>CH</sub> + t<sub>CL</sub> ≥ 1 / f<sub>C</sub>.

2. Value guaranteed by characterization, not 100% tested in production.

3. Current product: identified by Process Identification letter S.

4. New product: identified by Process Identification letter B.

勝特力材料 886-3-5753170  
 勝特力电子(上海) 86-21-54151736  
 勝特力电子(深圳) 86-755-83298787  
[Http://www.100y.com.tw](http://www.100y.com.tw)

Table 20. AC Characteristics (M95xxx-W, temperature range 6)

Test conditions specified in Table 11 and Table 9							
Symbol	Alt.	Parameter	Min. <sup>3</sup>	Max. <sup>3</sup>	Min. <sup>4</sup>	Max. <sup>4</sup>	Unit
f <sub>C</sub>	f <sub>SCK</sub>	Clock Frequency	D.C.	2	D.C.	5	MHz
t <sub>SLCH</sub>	t <sub>CSS1</sub>	$\overline{S}$ Active Setup Time	200		90		ns
t <sub>SHCH</sub>	t <sub>CSS2</sub>	$\overline{S}$ Not Active Setup Time	200		90		ns
t <sub>SHSL</sub>	t <sub>CS</sub>	$\overline{S}$ Deselect Time	200		100		ns
t <sub>CHSH</sub>	t <sub>CSH</sub>	$\overline{S}$ Active Hold Time	200		90		ns
t <sub>CHSL</sub>		$\overline{S}$ Not Active Hold Time	200		90		ns
t <sub>CH</sub> <sup>1</sup>	t <sub>CLH</sub>	Clock High Time	200		90		ns
t <sub>CL</sub> <sup>1</sup>	t <sub>CLL</sub>	Clock Low Time	200		90		ns
t <sub>CLCH</sub> <sup>2</sup>	t <sub>RC</sub>	Clock Rise Time		1		1	μs
t <sub>CHCL</sub> <sup>2</sup>	t <sub>FC</sub>	Clock Fall Time		1		1	μs
t <sub>DVCH</sub>	t <sub>DSU</sub>	Data In Setup Time	40		20		ns
t <sub>CHDX</sub>	t <sub>DH</sub>	Data In Hold Time	50		30		ns
t <sub>HHCH</sub>		Clock Low Hold Time after $\overline{HOLD}$ not Active	140		70		ns
t <sub>HLCH</sub>		Clock Low Hold Time after $\overline{HOLD}$ Active	90		40		ns
t <sub>CHHL</sub>		Clock High Set-up Time before $\overline{HOLD}$ Active	120		60		ns
t <sub>CHHH</sub>		Clock High Set-up Time before $\overline{HOLD}$ not Active	120		60		ns
t <sub>SHQZ</sub> <sup>2</sup>	t <sub>DIS</sub>	Output Disable Time		250		100	ns
t <sub>CLQV</sub>	t <sub>V</sub>	Clock Low to Output Valid		150		60	ns
t <sub>CLQX</sub>	t <sub>HO</sub>	Output Hold Time	0		0		ns
t <sub>QLQH</sub> <sup>2</sup>	t <sub>RO</sub>	Output Rise Time		100		50	ns
t <sub>QHQL</sub> <sup>2</sup>	t <sub>FO</sub>	Output Fall Time		100		50	ns
t <sub>HHQX</sub> <sup>2</sup>	t <sub>LZ</sub>	$\overline{HOLD}$ High to Output Low-Z		100		50	ns
t <sub>HLQZ</sub> <sup>2</sup>	t <sub>HZ</sub>	$\overline{HOLD}$ Low to Output High-Z		250		100	ns
t <sub>W</sub>	t <sub>WC</sub>	Write Time		10		5	ms

Note: 1.  $t_{CH} + t_{CL} \geq 1/f_C$ .

2. Value guaranteed by characterization, not 100% tested in production.

3. Current product: identified by Process Identification letter S.

4. New product: identified by Process Identification letter V.

勝特力材料 886-3-5753170  
 勝特力电子(上海) 86-21-54151736  
 勝特力电子(深圳) 86-755-83298787  
[Http://www.100y.com.tw](http://www.100y.com.tw)

Table 21. AC Characteristics (M95xxx-W, temperature range 3)

Test conditions specified in Table 11 and Table 9					
Symbol	Alt.	Parameter	Min.	Max.	Unit
f <sub>C</sub>	f <sub>SCK</sub>	Clock Frequency	D.C.	5	MHz
t <sub>SLCH</sub>	t <sub>CSS1</sub>	$\overline{S}$ Active Setup Time	90		ns
t <sub>SHCH</sub>	t <sub>CSS2</sub>	$\overline{S}$ Not Active Setup Time	90		ns
t <sub>SHSL</sub>	t <sub>CS</sub>	$\overline{S}$ Deselect Time	100		ns
t <sub>CHSH</sub>	t <sub>CSH</sub>	$\overline{S}$ Active Hold Time	90		ns
t <sub>CHSL</sub>		$\overline{S}$ Not Active Hold Time	90		ns
t <sub>CH</sub> <sup>1</sup>	t <sub>CLH</sub>	Clock High Time	90		ns
t <sub>CL</sub> <sup>1</sup>	t <sub>CLL</sub>	Clock Low Time	90		ns
t <sub>CLCH</sub> <sup>2</sup>	t <sub>RC</sub>	Clock Rise Time		1	μs
t <sub>CHCL</sub> <sup>2</sup>	t <sub>FC</sub>	Clock Fall Time		1	μs
t <sub>DVCH</sub>	t <sub>DSU</sub>	Data In Setup Time	20		ns
t <sub>CHDX</sub>	t <sub>DH</sub>	Data In Hold Time	30		ns
t <sub>HHCH</sub>		Clock Low Hold Time after $\overline{HOLD}$ not Active	70		ns
t <sub>HLCH</sub>		Clock Low Hold Time after $\overline{HOLD}$ Active	40		ns
t <sub>CHHL</sub>		Clock High Set-up Time before $\overline{HOLD}$ Active	60		ns
t <sub>CHHH</sub>		Clock High Set-up Time before $\overline{HOLD}$ not Active	60		ns
t <sub>SHQZ</sub> <sup>2</sup>	t <sub>DIS</sub>	Output Disable Time		100	ns
t <sub>CLQV</sub>	t <sub>V</sub>	Clock Low to Output Valid		60	ns
t <sub>CLQX</sub>	t <sub>HO</sub>	Output Hold Time	0		ns
t <sub>QLQH</sub> <sup>2</sup>	t <sub>RO</sub>	Output Rise Time		50	ns
t <sub>QHQL</sub> <sup>2</sup>	t <sub>FO</sub>	Output Fall Time		50	ns
t <sub>HHQX</sub> <sup>2</sup>	t <sub>LZ</sub>	$\overline{HOLD}$ High to Output Low-Z		50	ns
t <sub>HLQZ</sub> <sup>2</sup>	t <sub>HZ</sub>	$\overline{HOLD}$ Low to Output High-Z		100	ns
t <sub>W</sub>	t <sub>WC</sub>	Write Time		5	ms

Note: 1. t<sub>CH</sub> + t<sub>CL</sub> ≥ 1 / f<sub>C</sub>.

2. Value guaranteed by characterization, not 100% tested in production.

3. New product: identified by Process Identification letter B.

勝特力材料 886-3-5753170  
 勝特力电子(上海) 86-21-54151736  
 勝特力电子(深圳) 86-755-83298787  
[Http://www.100y.com.tw](http://www.100y.com.tw)

Table 22. AC Characteristics (M95xxx-R)

Test conditions specified in Table 11 and Table 10					
Symbol	Alt.	Parameter	Min. <sup>3</sup>	Max. <sup>3</sup>	Unit
f <sub>C</sub>	f <sub>SCK</sub>	Clock Frequency	D.C.	2	MHz
t <sub>SLCH</sub>	t <sub>CSS1</sub>	$\overline{S}$ Active Setup Time	200		ns
t <sub>SHCH</sub>	t <sub>CSS2</sub>	$\overline{S}$ Not Active Setup Time	200		ns
t <sub>SHSL</sub>	t <sub>CS</sub>	$\overline{S}$ Deselect Time	200		ns
t <sub>CHSH</sub>	t <sub>CSH</sub>	$\overline{S}$ Active Hold Time	200		ns
t <sub>CHSL</sub>		$\overline{S}$ Not Active Hold Time	200		ns
t <sub>CH</sub> <sup>1</sup>	t <sub>CLH</sub>	Clock High Time	200		ns
t <sub>CL</sub> <sup>1</sup>	t <sub>CLL</sub>	Clock Low Time	200		ns
t <sub>CLCH</sub> <sup>2</sup>	t <sub>RC</sub>	Clock Rise Time		1	μs
t <sub>CHCL</sub> <sup>2</sup>	t <sub>FC</sub>	Clock Fall Time		1	μs
t <sub>DVCH</sub>	t <sub>DSU</sub>	Data In Setup Time	40		ns
t <sub>CHDX</sub>	t <sub>DH</sub>	Data In Hold Time	50		ns
t <sub>HHCH</sub>		Clock Low Hold Time after $\overline{HOLD}$ not Active	140		ns
t <sub>HLCH</sub>		Clock Low Hold Time after $\overline{HOLD}$ Active	90		ns
t <sub>CHHL</sub>		Clock High Set-up Time before $\overline{HOLD}$ Active	120		ns
t <sub>CHHH</sub>		Clock High Set-up Time before $\overline{HOLD}$ not Active	120		ns
t <sub>SHQZ</sub> <sup>2</sup>	t <sub>DIS</sub>	Output Disable Time		250	ns
t <sub>CLQV</sub>	t <sub>V</sub>	Clock Low to Output Valid		150	ns
t <sub>CLQX</sub>	t <sub>HO</sub>	Output Hold Time	0		ns
t <sub>QLQH</sub> <sup>2</sup>	t <sub>RO</sub>	Output Rise Time		100	ns
t <sub>QHQL</sub> <sup>2</sup>	t <sub>FO</sub>	Output Fall Time		100	ns
t <sub>HHQX</sub> <sup>2</sup>	t <sub>LZ</sub>	$\overline{HOLD}$ High to Output Low-Z		100	ns
t <sub>HLQZ</sub> <sup>2</sup>	t <sub>HZ</sub>	$\overline{HOLD}$ Low to Output High-Z		250	ns
t <sub>W</sub>	t <sub>WC</sub>	Write Time		10	ms

Note: 1. t<sub>CH</sub> + t<sub>CL</sub> ≥ 1 / f<sub>C</sub>.

2. Value guaranteed by characterization, not 100% tested in production.

3. Preliminary data: this product is under qualification. For more information, please contact your nearest ST sales office.

勝特力材料 886-3-5753170  
 勝特力电子(上海) 86-21-54151736  
 勝特力电子(深圳) 86-755-83298787  
[Http://www.100y.com.tw](http://www.100y.com.tw)

Figure 17. Serial Input Timing

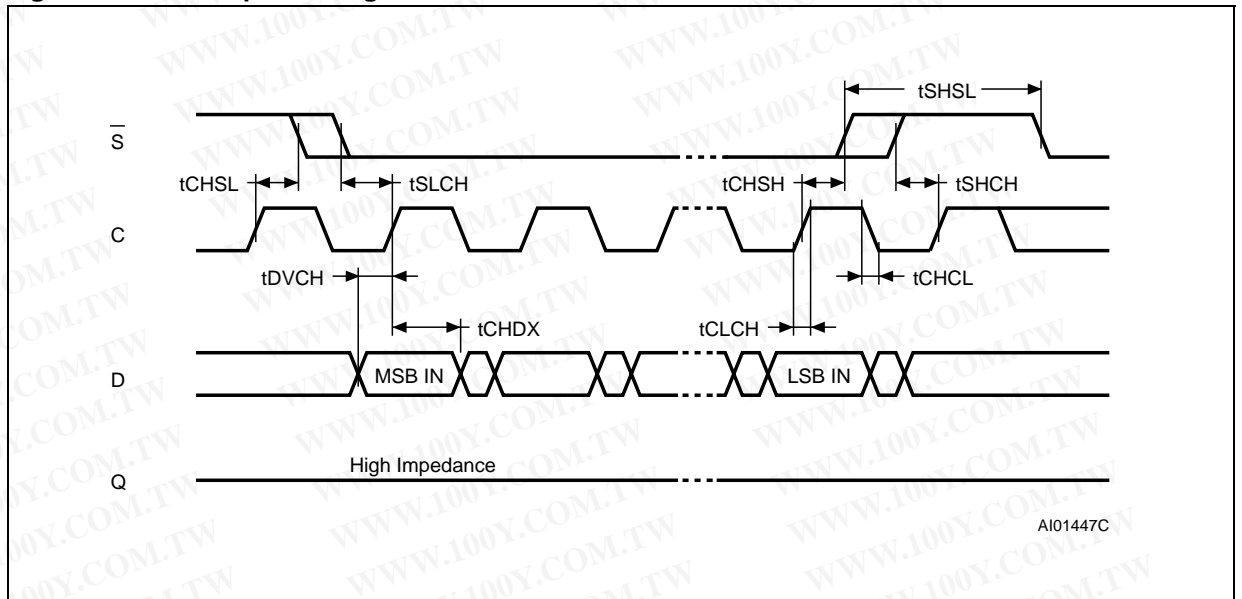
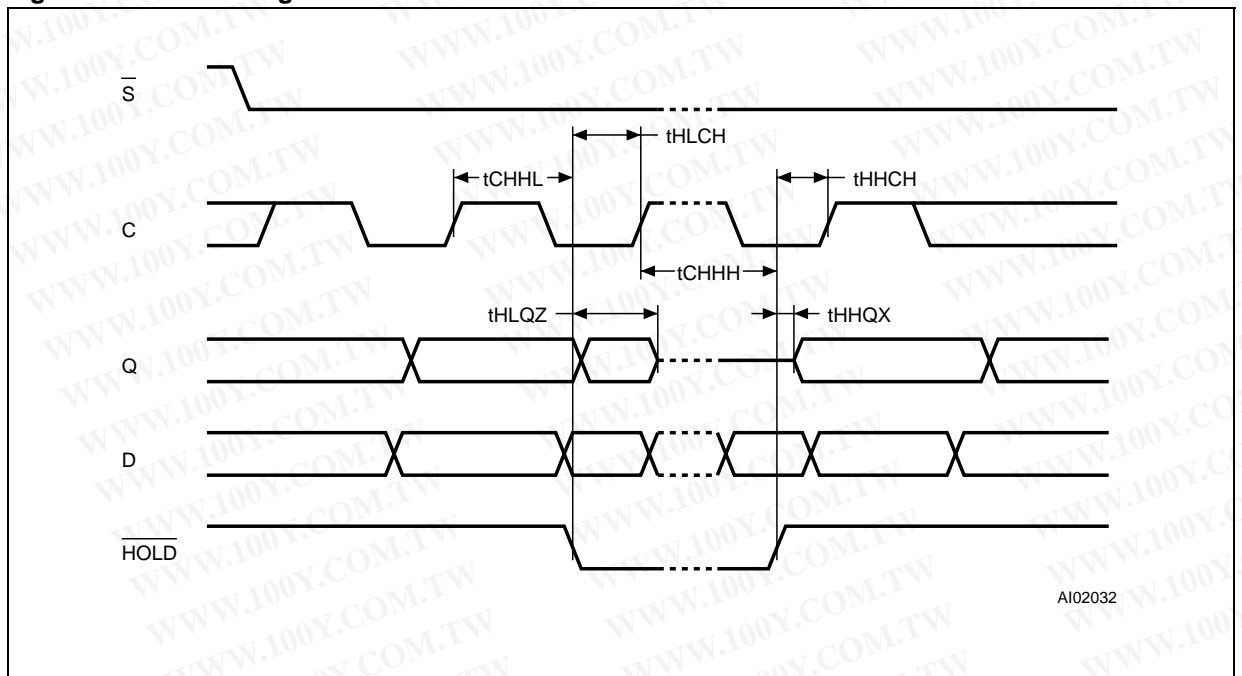
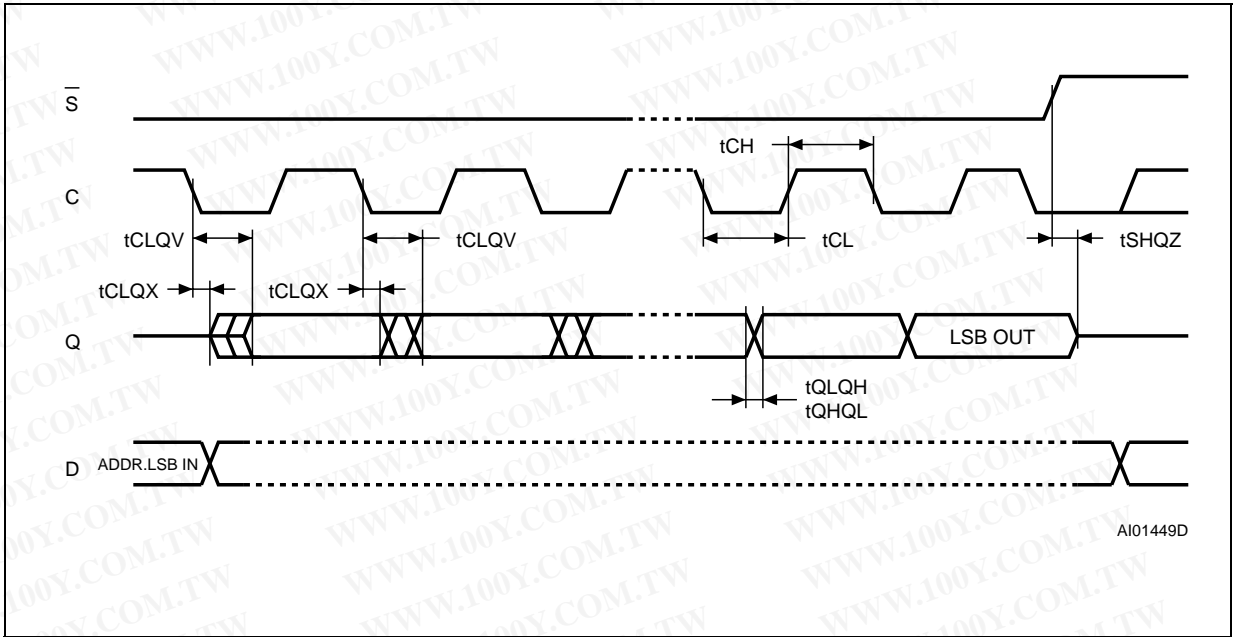

Figure 18. Hold Timing



勝特力材料 886-3-5753170  
 勝特力电子(上海) 86-21-54151736  
 勝特力电子(深圳) 86-755-83298787  
[Http://www.100y.com.tw](http://www.100y.com.tw)

Figure 19. Output Timing



A101449D

勝特力材料 886-3-5753170  
勝特力电子(上海) 86-21-54151736  
勝特力电子(深圳) 86-755-83298787  
[Http://www.100y.com.tw](http://www.100y.com.tw)



PACKAGE MECHANICAL

Figure 20. PDIP8 – 8 pin Plastic DIP, 0.25mm lead frame, Package Outline

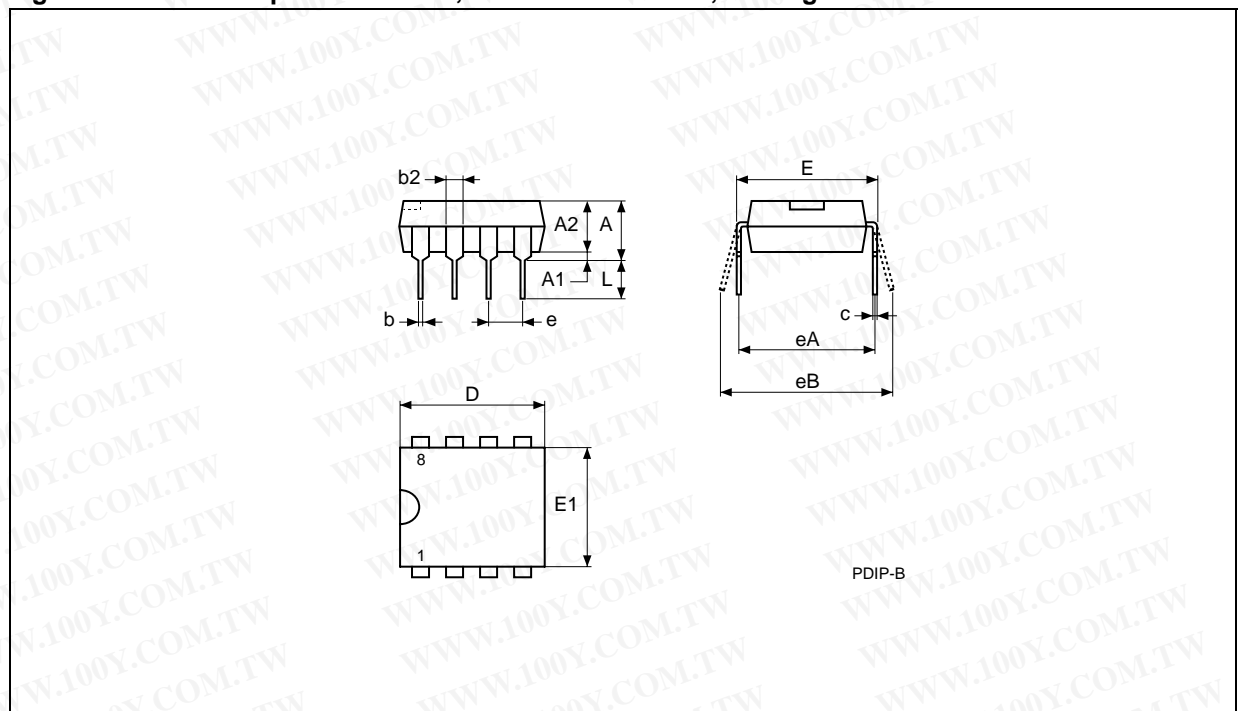

Notes: 1. Drawing is not to scale.

Table 23. PDIP8 – 8 pin Plastic DIP, 0.25mm lead frame, Package Mechanical Data

Symb.	mm			inches		
	Typ.	Min.	Max.	Typ.	Min.	Max.
A			5.33			0.210
A1		0.38			0.015	
A2	3.30	2.92	4.95	0.130	0.115	0.195
b	0.46	0.36	0.56	0.018	0.014	0.022
b2	1.52	1.14	1.78	0.060	0.045	0.070
c	0.25	0.20	0.36	0.010	0.008	0.014
D	9.27	9.02	10.16	0.365	0.355	0.400
E	7.87	7.62	8.26	0.310	0.300	0.325
E1	6.35	6.10	7.11	0.250	0.240	0.280
e	2.54	–	–	0.100	–	–
eA	7.62	–	–	0.300	–	–
eB			10.92			0.430
L	3.30	2.92	3.81	0.130	0.115	0.150

Figure 21. SO8 narrow – 8 lead Plastic Small Outline, 150 mils body width, Package Outline

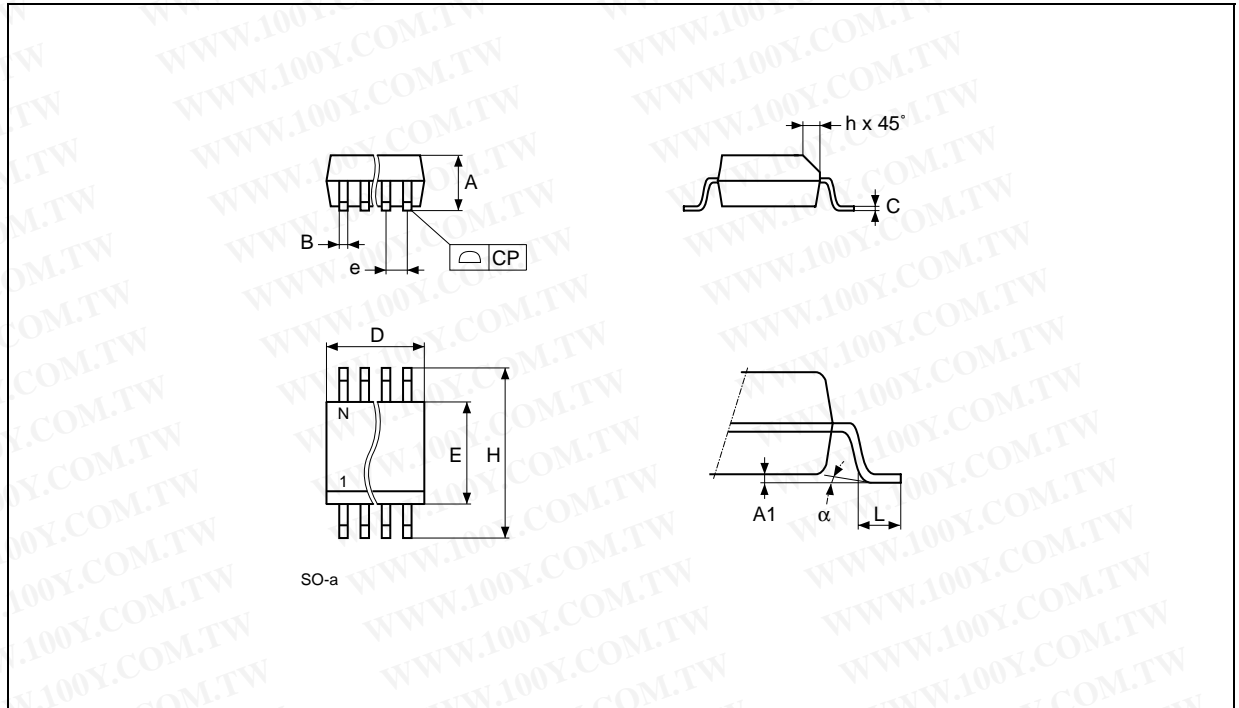

Note: Drawing is not to scale.

Table 24. SO8 narrow – 8 lead Plastic Small Outline, 150 mils body width, Package Mechanical Data

Symb.	mm			inches			
	Typ.	Min.	Max.	Typ.	Min.	Max.	
A		1.35	1.75		0.053	0.069	
A1		0.10	0.25		0.004	0.010	
B		0.33	0.51		0.013	0.020	
C		0.19	0.25		0.007	0.010	
D		4.80	5.00		0.189	0.197	
E		3.80	4.00		0.150	0.157	
e	1.27	–	–	0.050	–	–	
H		5.80	6.20		0.228	0.244	
h		0.25	0.50		0.010	0.020	
L		0.40	0.90		0.016	0.035	
α		0°	8°		0°	8°	
N		8			8		
CP			0.10			0.004	

勝特力材料 886-3-5753170  
 勝特力电子(上海) 86-21-54151736  
 勝特力电子(深圳) 86-755-83298787  
[Http://www.100y.com.tw](http://www.100y.com.tw)

Figure 22. TSSOP8 – 8 lead Thin Shrink Small Outline, Package Outline

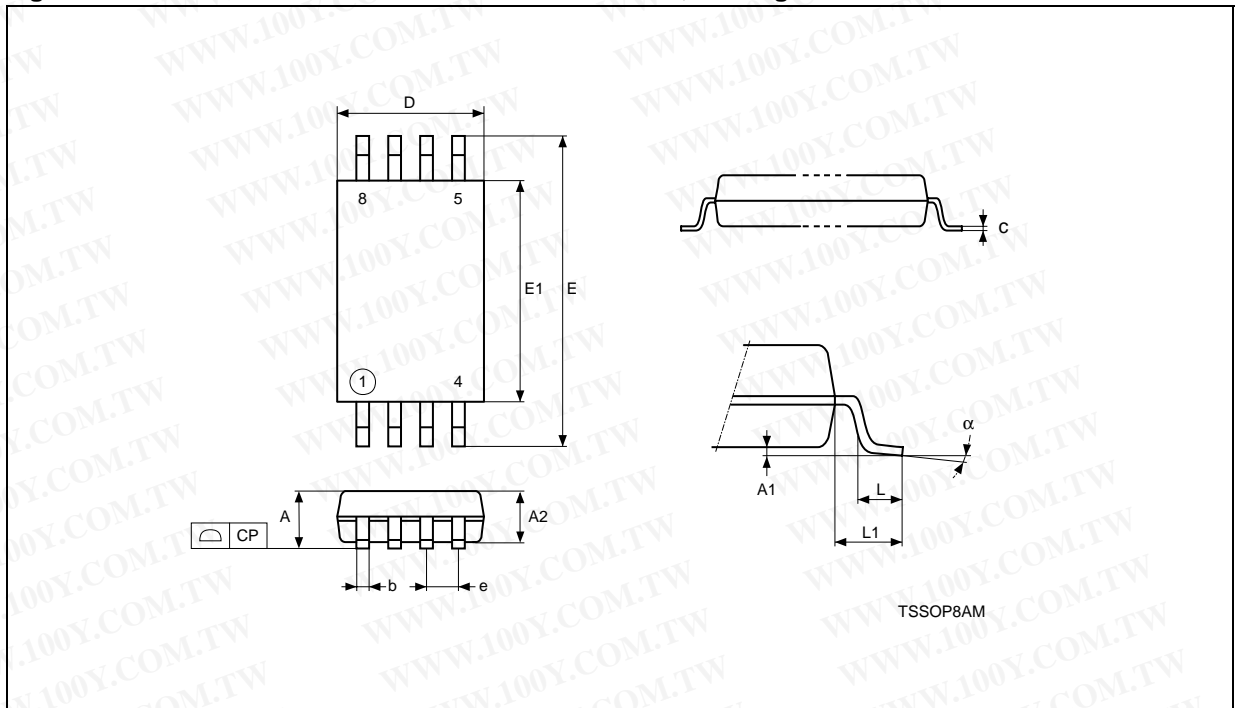

Notes: 1. Drawing is not to scale.

Table 25. TSSOP8 – 8 lead Thin Shrink Small Outline, Package Mechanical Data

Symbol	mm			inches		
	Typ.	Min.	Max.	Typ.	Min.	Max.
A			1.200			0.0472
A1		0.050	0.150		0.0020	0.0059
A2	1.000	0.800	1.050	0.0394	0.0315	0.0413
b		0.190	0.300		0.0075	0.0118
c		0.090	0.200		0.0035	0.0079
CP			0.100			0.0039
D	3.000	2.900	3.100	0.1181	0.1142	0.1220
e	0.650	–	–	0.0256	–	–
E	6.400	6.200	6.600	0.2520	0.2441	0.2598
E1	4.400	4.300	4.500	0.1732	0.1693	0.1772
L	0.600	0.450	0.750	0.0236	0.0177	0.0295
L1	1.000			0.0394		
$\alpha$		0°	8°		0°	8°

勝特力材料 886-3-5753170  
 勝特力电子(上海) 86-21-54151736  
 勝特力电子(深圳) 86-755-83298787  
[Http://www.100y.com.tw](http://www.100y.com.tw)

Figure 23. TSSOP14 - 14 lead Thin Shrink Small Outline, Package Outline

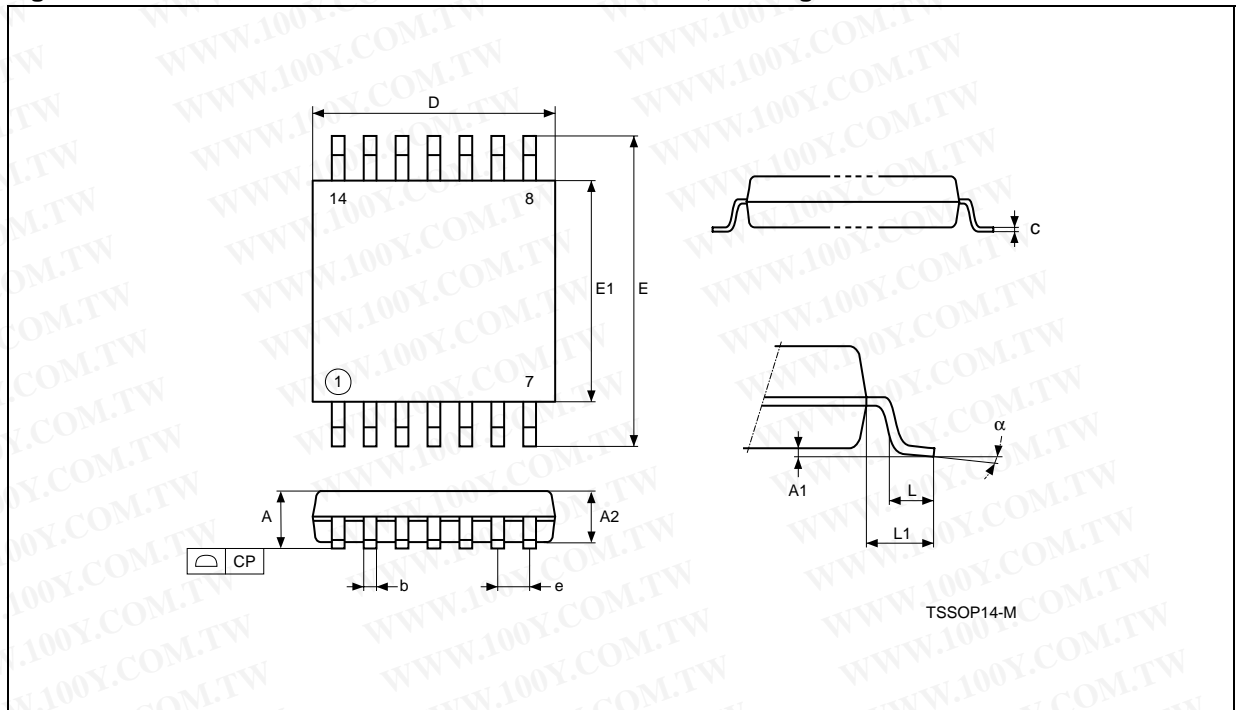

Notes: 1. Drawing is not to scale.

Table 26. TSSOP14 - 14 lead Thin Shrink Small Outline, Package Mechanical Data

Symbol	mm			inches		
	Typ.	Min.	Max.	Typ.	Min.	Max.
A			1.200			0.0472
A1		0.050	0.150		0.0020	0.0059
A2	1.000	0.800	1.050	0.0394	0.0315	0.0413
b		0.190	0.300		0.0075	0.0118
c		0.090	0.200		0.0035	0.0079
CP			0.100			0.0039
D	5.000	4.900	5.100	0.1969	0.1929	0.2008
e	0.650	—	—	0.0256	—	—
E	6.400	6.200	6.600	0.2520	0.2441	0.2598
E1	4.400	4.300	4.500	0.1732	0.1693	0.1772
L	0.600	0.500	0.750	0.0236	0.0197	0.0295
L1	1.000			0.0394		
α		0°	8°		0°	8°

勝特力材料 886-3-5753170  
 勝特力电子(上海) 86-21-54151736  
 勝特力电子(深圳) 86-755-83298787  
[Http://www.100y.com.tw](http://www.100y.com.tw)

## PART NUMBERING

Table 27. Ordering Information Scheme

Example:	M95320	-	W	MN	6	T	P
<b>Device Type</b> M95 = SPI serial access EEPROM							
<b>Device Function<sup>1</sup></b> 640 = 64 Kbit (8192 x 8) 320 = 32 Kbit (4096 x 8)							
<b>Operating Voltage</b> blank = V <sub>CC</sub> = 4.5 to 5.5V W = V <sub>CC</sub> = 2.5 to 5.5V R = V <sub>CC</sub> = 1.8 to 5.5V							
<b>Package</b> BN = PDIP8 MN = SO8 (150 mil width) DW = TSSOP8 (169 mil width) DL = TSSOP14 (169 mil width)							
<b>Temperature Range</b> 6 = -40 to 85 °C 3 = -40 to 125 °C							
<b>Option</b> blank = Standard Packing T = Tape & Reel Packing							
<b>Plating Technology</b> blank = Standard SnPb plating P = Pb-free plating G = Green pack							

Note: 1. Devices bearing the process identification letter "B" or "V" in the package marking (on the top side of the package, on the right side), guarantee more than 1 million Erase/Write cycle endurance (see Table 28, below). For more information about these devices, and their device identification, please contact your nearest ST sales office, and ask for the Product Change Notice.

For a list of available options (speed, package, etc.) or for further information on any aspect of this device, please contact your nearest ST Sales Office.

Table 28. How to Identify Current and Forthcoming Products by the Process Identification Letter

Markings on Current Products <sup>1</sup>	Markings on New Products <sup>1</sup>
95640 6 (or 95640W6) xxxxS	95640 6 (or 95640W6) xxxxV
95640 3 xxxxS	95640 3 (or 95640W3) xxxxB

Note: 1. For further information, please ask your ST Sales Office for Process Change Notice PCN MPG/EE/0053 (PCEE0053) and MPG/EE/0054 (PCEE0054).



勝特力材料 886-3-5753170  
 勝特力电子(上海) 86-21-54151736  
 勝特力电子(深圳) 86-755-83298787  
 Http://www.100y.com.tw

## REVISION HISTORY

Table 29. Document Revision History

Date	Rev.	Description of Revision
13-Jul-2000	1.2	Human Body Model meets JEDEC std (Table 2). Minor adjustments on pp 1,11,15. New clause on p7. Addition of TSSOP8 package on pp 1, 2, Ordering Info, Mechanical Data
16-Mar-2001	1.3	Test condition added I <sub>LI</sub> and I <sub>LO</sub> , and specification of t <sub>DLDH</sub> and t <sub>DHDL</sub> removed. t <sub>CLCH</sub> , t <sub>CHCL</sub> , t <sub>DLDH</sub> and t <sub>DHDL</sub> changed to 50ns for the -V range. "-V" Voltage range changed to "2.7V to 3.6V" throughout. Maximum lead soldering time and temperature conditions updated. Instruction sequence illustrations updated. "Bus Master and Memory Devices on the SPI bus" illustration updated. Package Mechanical data updated.
19-Jul-2001	1.4	M95160 and M95080 devices removed to their own data sheet
06-Dec-2001	1.5	Endurance increased to 1M write/erase cycles Instruction sequence illustrations updated
18-Dec-2001	2.0	Document reformatted using the new template. No parameters changed.
08-Feb-2002	2.1	Announcement made of planned upgrade to 10 MHz clock for the 5V, -40 to 85°C, range. Endurance set to 100K write/erase cycles
18-Dec-2002	2.2	10MHz, 5MHz, 2MHz clock; 5ms, 10ms Write Time; 100K, 1M erase/write cycles distinguished on front page, and in the DC and AC Characteristics tables
26-Mar-2003	2.3	Process indentification letter corrected in footnote to AC Characteristics table for temp. range 3
26-Jun-2003	2.4	-S voltage range upgraded by removing it and inserting -R voltage range in its place
15-Oct-2003	3.0	Table of contents, and Pb-free options added. V <sub>IL</sub> (min) improved to -0.45V.
21-Nov-2003	3.1	V <sub>I</sub> (min) and V <sub>O</sub> (min) corrected (improved) to -0.45V.