

EVALUATION KIT
 AVAILABLE

MAXIM

Adjustable-Output, Switch-Mode Current Sources with Synchronous Rectifier

General Description

The MAX1640/MAX1641 CMOS, adjustable-output, switch-mode current sources operate from a +5.5V to +26V input, and are ideal for microprocessor-controlled battery chargers. Charging current, maximum output voltage, and pulse-trickle charge are programmed with external resistors. Programming the off-time modifies the switching frequency, suppressing undesirable harmonics in noise-sensitive circuits. The MAX1640's high-side current sensing allows the load to connect directly to ground, eliminating ground-potential errors. The MAX1641 incorporates a low-side current sense.

The MAX1640/MAX1641 step-down pulse-width-modulation (PWM) controllers use an external P-channel MOSFET switch and an optional, external N-channel MOSFET synchronous rectifier for increased efficiency. An internal low-dropout linear regulator provides power for the internal reference and circuitry as well as the gate drive for the N-channel synchronous rectifier.

The MAX1640/MAX1641 are available in space-saving, 16-pin narrow QSOP packages.

Applications

Battery-Powered Equipment
 Laptop, Notebook, and Palmtop Computers
 Handy Terminals
 Portable Consumer Products
 Cordless Phones
 Cellular Phones
 PCS Phones
 Backup Battery Charger

Pin Configuration

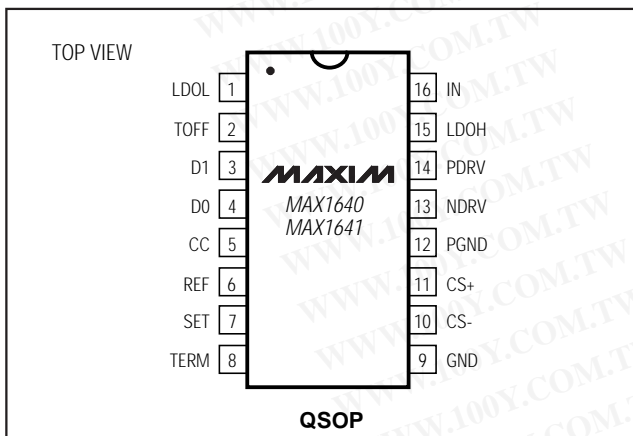

Features

- ◆ 95% Efficiency
- ◆ +5.5V to +26V Input Supply Range
- ◆ 2V to 24V Adjustable-Output Voltage Range
- ◆ 100% Maximum Duty Cycle (Low Dropout)
- ◆ Up to 500kHz PWM Operation
- ◆ Optional Synchronous Rectifier
- ◆ 16-Pin QSOP Package
- ◆ Current-Sense Accuracy: 2% (MAX1641)
5.3% (MAX1640)

Ordering Information

PART	TEMP. RANGE	PIN-PACKAGE
MAX1640C/D	0°C to +70°C	Dice*
MAX1640EEE	-40°C to +85°C	16 QSOP
MAX1641C/D	0°C to +70°C	Dice*
MAX1641EEE	-40°C to +85°C	16 QSOP

*Dice are specified at $T_A = +25^\circ\text{C}$, DC parameters only.

Typical Operating Circuit

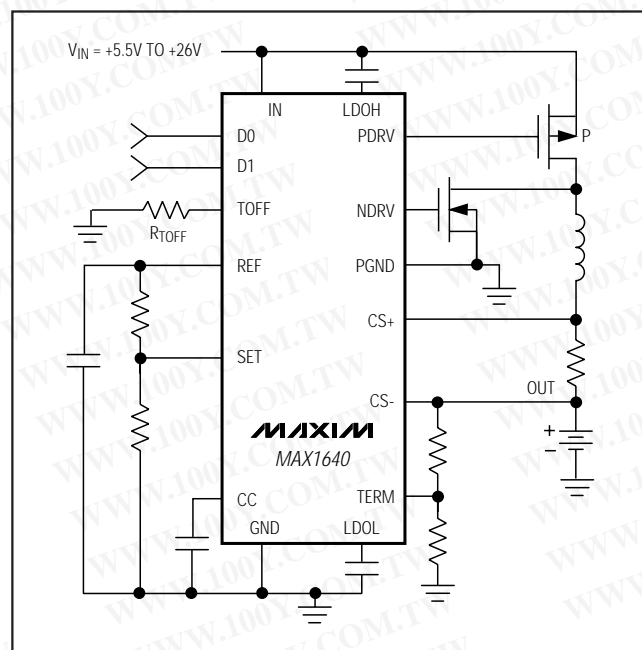

MAXIM

Maxim Integrated Products 1

For free samples & the latest literature: <http://www.maxim-ic.com>, or phone 1-800-998-8800.
 For small orders, phone 408-737-7600 ext. 3468.

MAX1640/MAX1641

Adjustable-Output, Switch-Mode Current Source with Synchronous Rectifier

ABSOLUTE MAXIMUM RATINGS

IN to GND	-0.3V to +28V	PGND to GND	±0.3V
LDOH to IN	+0.3V to -6V	Continuous Power Dissipation (T _A = +70°C)	
LDOL to GND	-0.3V to +6V	QSOP (derate 8.30mW/°C above +70°C)	667mW
PDRV to GND	(V _{LDOH} - 0.3V) to (V _{IN} + 0.3V)	Operating Temperature Range	
NDRV to GND	-0.3V to (V _{LDOL} + 0.3V)	MAX164_EEE	-40°C to +85°C
TOFF, REF, SET, TERM, CC to GND	-0.3V to (V _{LDOL} + 0.3V)	Storage Temperature Range	-65°C to +150°C
D0, D1 to GND	-0.3V to +6V	Lead Temperature (soldering, 10sec)	+300°C
CS+, CS- to GND	-0.3V to +28V		

Stresses beyond those listed under "Absolute Maximum Ratings" may cause permanent damage to the device. These are stress ratings only, and functional operation of the device at these or any other conditions beyond those indicated in the operational sections of the specifications is not implied. Exposure to absolute maximum rating conditions for extended periods may affect device reliability.

ELECTRICAL CHARACTERISTICS

(V_{IN} = +12V, V_{OUT} = 6V, Circuit of Figure 2, T_A = 0°C to +85°C, unless otherwise noted. Typical values are at T_A = +25°C.)

PARAMETER	SYMBOL	CONDITIONS	MIN	TYP	MAX	UNITS
Input Voltage Range	V _{IN}		5.5		26	V
Linear-Regulator Output Voltage, V _{IN} Referenced	V _{LDOH}	V _{IN} = 5.5V to 26V, I _{LOAD} = 0 to 20mA	V _{IN} - 5.5	V _{IN} - 5.0	V _{IN} - 4.5	V
Linear-Regulator Output Voltage, Ground Referenced	V _{LDOL}	V _{IN} = 5.5V to 26V, I _{LOAD} = 0 to 20mA	4.5	5.0	5.5	V
Full-Scale Current-Sense Threshold		MAX1640	142	150	158	mV
		MAX1641	147	150	153	
Quarter-Scale Current-Sense Threshold		MAX1640	36	42	48	mV
		MAX1641	34	37.5	41	
Current-Sense Line Regulation		V _{IN} = V _{OUT} + 0.5V to 26V		0.03		%/V
Output Current Compliance		V _{OUT} = 2V to 24V	MAX1640	0.1	0.4	%/V
			MAX1641	0.1		
Quiescent V _{IN} Supply Current		D0 or D1 = high		2	4	mA
		D0 = D1 = low (off mode)		500		
Output Current in Off Mode		D0 = D1 = low			1	μA
V _{LDOL} Undervoltage Lockout			4.05	4.20	4.35	V
Reference Voltage	V _{REF}		1.96	2.00	2.04	V
Reference Load Regulation		I _{REF} = 0 to 50μA		4	10	mV
V _{SET} Input Current					1	μA
FET Drive Output Resistance		PFET and NFET drive			12	Ω
Off-Time Range			1		10	μs
Off-Time Accuracy		R _{TOFF} = 62kΩ	1.7	2.2	2.7	μs
Pulse-Trickle Mode Duty-Cycle Period		D0 = low, D1 = high, R _{TOFF} = 100kΩ	27	33	40	ms
Pulse-Trickle Mode Duty Cycle (Note 1)		D0 = low, D1 = high, R _{TOFF} = 100kΩ		12.5		%

Note 1: This ratio is generated by a 1:8 clock divider and is not an error source for current calculations.

Adjustable-Output, Switch-Mode Current Source with Synchronous Rectifier

MAX1640/MAX1641

ELECTRICAL CHARACTERISTICS (continued)

($V_{IN} = +12V$, $V_{OUT} = 6V$, Circuit of Figure 2, $T_A = 0^{\circ}C$ to $+85^{\circ}C$, unless otherwise noted. Typical values are at $T_A = +25^{\circ}C$.)

PARAMETER	SYMBOL	CONDITIONS	MIN	TYP	MAX	UNITS
PWM Maximum Duty Cycle			100			%
Input Low Voltage	V_{IL}	D0, D1			0.8	V
Input High Voltage	V_{IH}	D0, D1	2.4			V
Input Leakage Current	I_{IN}	D0, D1			± 1	μA

ELECTRICAL CHARACTERISTICS

($V_{IN} = +12V$, $V_{OUT} = 6V$, Circuit of Figure 2, $T_A = -40^{\circ}C$ to $+85^{\circ}C$, unless otherwise noted.)

PARAMETER	SYMBOL	CONDITIONS	MIN	TYP	MAX	UNITS
Input Voltage Range	V_{IN}		5.5		26	V
Linear-Regulator Output Voltage, V_{IN} Referenced	V_{LDOH}	$V_{IN} = 5.5V$ to $26V$, $I_{LOAD} = 0$ to $20mA$	$V_{IN} - 5.5$		$V_{IN} - 4.5$	V
Linear-Regulator Output Voltage, Ground Referenced	V_{LDOL}	$V_{IN} = 5.5V$ to $26V$, $I_{LOAD} = 0$ to $20mA$	4.5		5.5	V
Full-Scale Current-Sense Threshold		MAX1640	141		159	mV
		MAX1641	146		154	
Quarter-Scale Current-Sense Threshold		MAX1640	34		48	mV
		MAX1641	33		42	
Output Current Compliance		$V_{OUT} = 2V$ to $24V$ (MAX1640)			0.4	%/V
Quiescent V_{IN} Supply Current		D0 or D1 = high			4	mA
Output Current in Off Mode		D0 = D1 = low			1	μA
V_{LDOL} Undervoltage Lockout			4.0		4.4	V
Reference Voltage	V_{REF}		1.94		2.06	V
Reference Load Regulation		$I_{REF} = 0$ to $50\mu A$			10	mV
V_{SET} Input Current					1	μA
FET Drive Output Resistance					12	Ω
Off-Time Range			1.5		8	μs
Off-Time Accuracy		$R_{TOFF} = 62k\Omega$	1.5		2.5	μs
Pulse-Trickle Mode Duty-Cycle Period		D0 = low, D1 = high, $R_{TOFF} = 50k\Omega$	25		42	ms
PWM Maximum Duty Cycle			100			%
Input Low Voltage	V_{IL}	D0, D1			0.8	V
Input High Voltage	V_{IH}	D0, D1	2.4			V
Input Leakage Current	I_{IN}	D0, D1			± 1	μA

Adjustable-Output, Switch-Mode Current Source with Synchronous Rectifier

Typical Operating Characteristics

(Circuit of Figure 2, $T_A = +25^\circ\text{C}$, unless otherwise noted.)

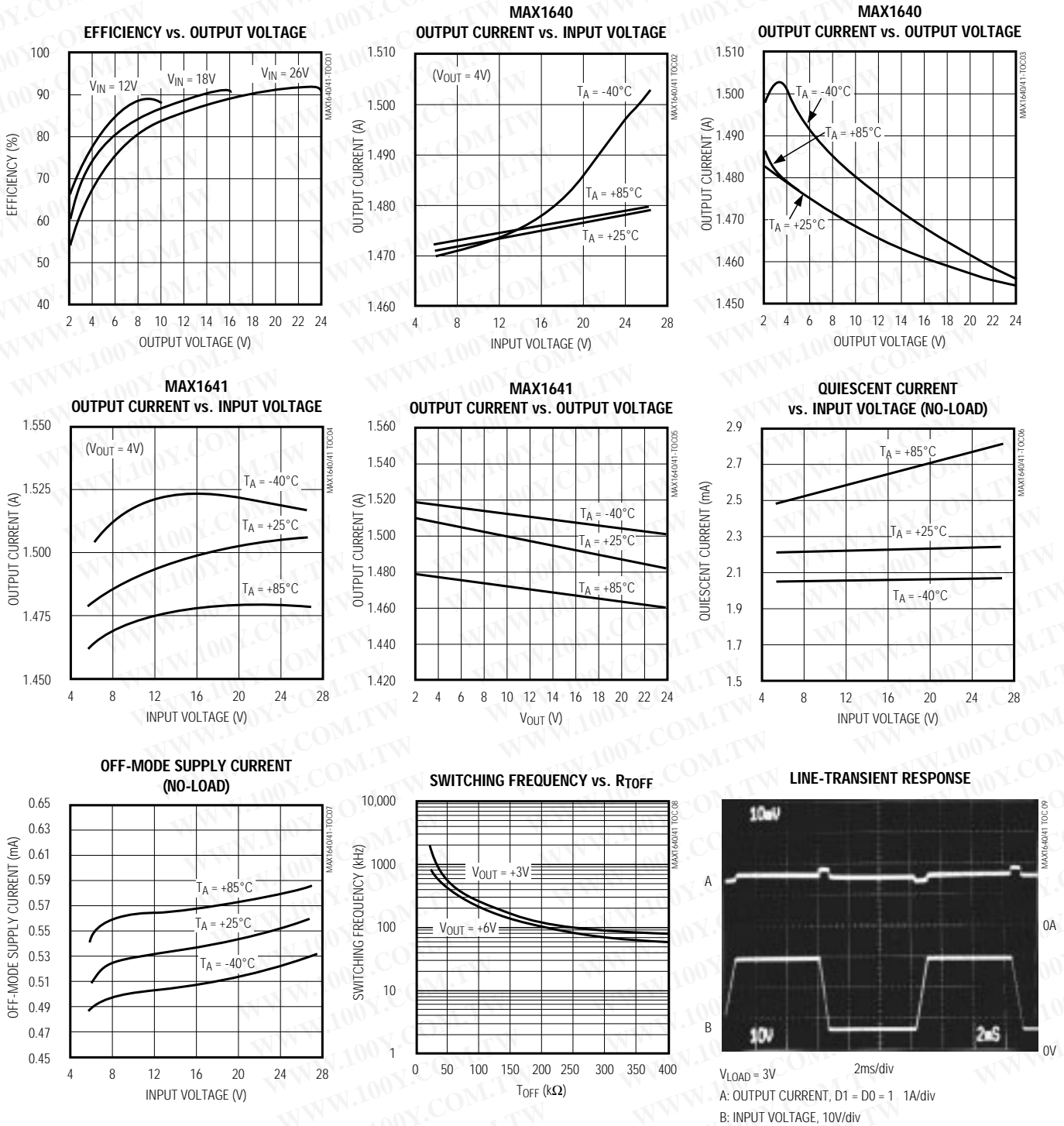

勝特力材料 886-3-5753170
 勝特力电子(上海) 86-21-54151736
 勝特力电子(深圳) 86-755-83298787
[Http://www.100y.com.tw](http://www.100y.com.tw)

Adjustable-Output, Switch-Mode Current Source with Synchronous Rectifier

Typical Operating Characteristics (continued)

(Circuit of Figure 2, $T_A = +25^\circ\text{C}$, unless otherwise noted.)

CURRENT-MODE CHANGE RESPONSE TIME

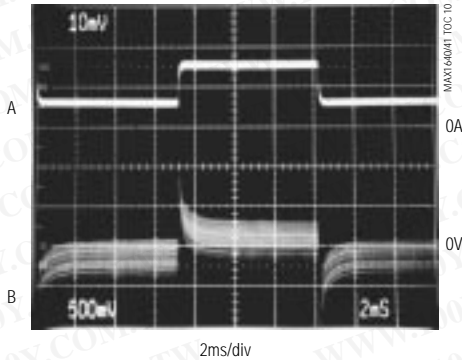

$V_{IN} = 12\text{V}$, $V_{SET} = 1\text{V}$, $R_{LOAD} = 4\Omega$, NO OUTPUT CAPACITOR
A: OUTPUT CURRENT, $D_0 = D_1 = 0$ 1A/div
B: LOAD VOLTAGE, AC coupled, 500mV/div

EXITING OFF MODE

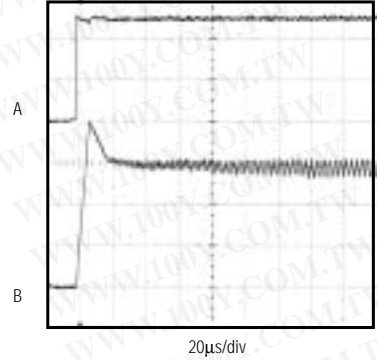

$V_{IN} = 12\text{V}$, $R_{LOAD} = 4\Omega$
A: $D_0 = D_1 = 1$ 2V/div
B: OUTPUT CURRENT, 0.5A/div

Pin Description

PIN	NAME	FUNCTION
1	LDOL	Internal, Ground-Referenced Low-Dropout Linear Regulator Output. Bypass with a 0.1µF capacitor in parallel with a 4.7µF capacitor to GND.
2	TOFF	Off-Time Select Input. A resistor (R_{TOFF}) connected from this pin to GND programs the off-time for the hysteretic PWM step-down converter. This resistor also sets the period in duty-cycle mode. See <i>Duty-Cycle Mode and Programming the Off-Time</i> .
3, 4	D1, D0	Digital Inputs. Select mode of operation (Table 1).
5	CC	Constant-Current Loop Compensation Input. Bypass with a 0.01µF capacitor to GND.
6	REF	Reference Voltage Output ($V_{REF} = 2\text{V}$). Bypass with a 0.1µF capacitor to GND.
7	SET	Current Select Input. Program the desired current level by applying a voltage at SET between 0V and V_{REF} , ($I = V_{SET} / 13.3R_{SENSE}$). See Figure 3.
8	TERM	Maximum Output Voltage Termination Input. When V_{TERM} exceeds the reference voltage, the comparator resets the internal PWM latch, shutting off the external P-channel FET.
9	GND	Ground
10	CS-	Negative Current-Sense Comparator Input
11	CS+	Positive Current-Sense Comparator Input
12	PGND	High-Current Ground Return for the output drivers
13	NDRV	Gate Drive for an optional N-channel FET synchronous rectifier
14	PDRV	Gate Drive for the P-channel FET
15	LDOH	Internal, Input-Referenced Low-Dropout Linear Regulator Output. Bypass with a 0.33µF capacitor to IN.
16	IN	Power-Supply Input. Input of the internal, low-dropout linear regulators.

Adjustable-Output, Switch-Mode Current Source with Synchronous Rectifier

MAX1640/MAX1641

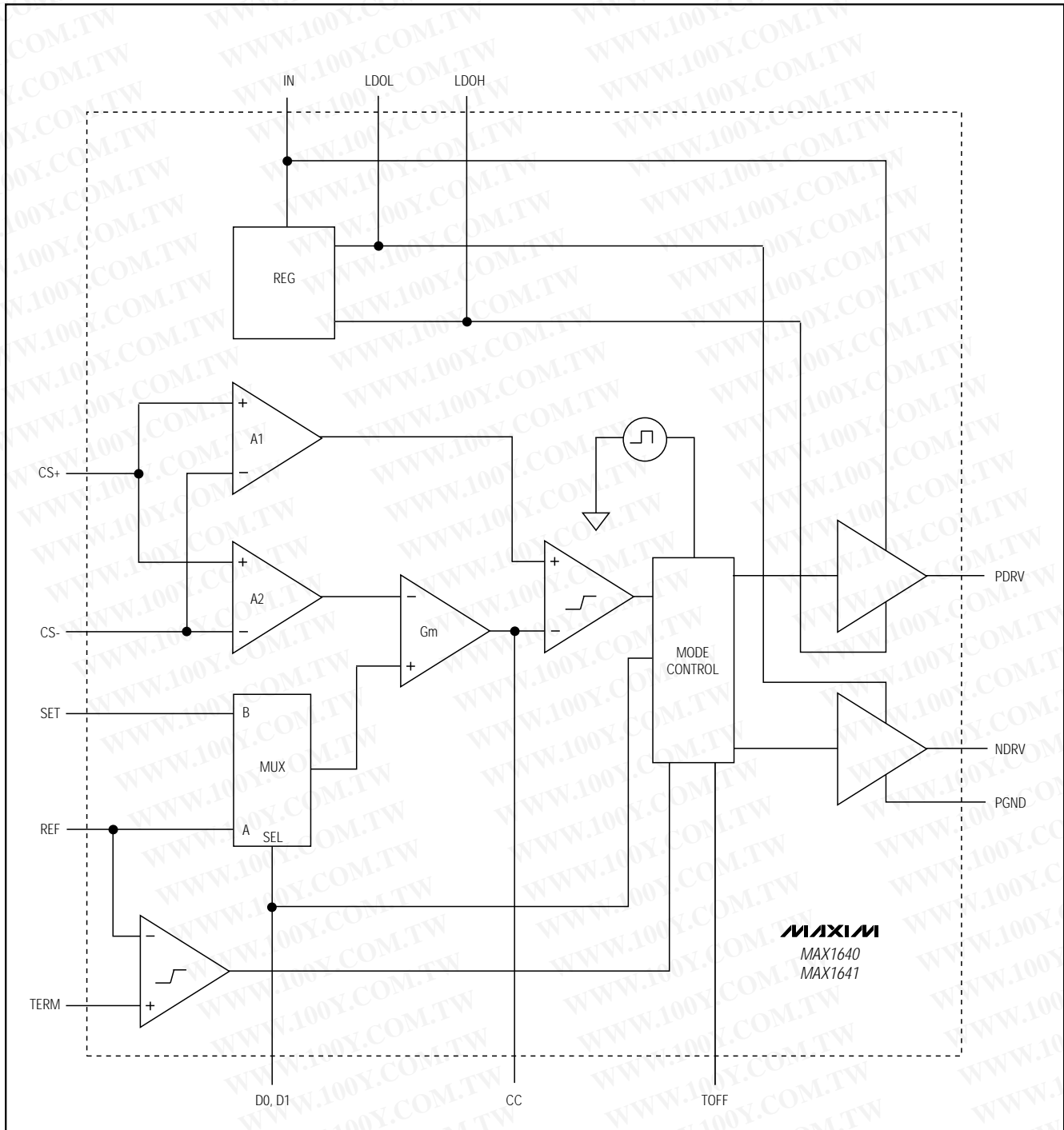

Figure 1. MAX1640/MAX1641 Functional Diagram

勝特力材料 886-3-5753170
 勝特力电子(上海) 86-21-54151736
 勝特力电子(深圳) 86-755-83298787
[Http://www.100y.com.tw](http://www.100y.com.tw)

Adjustable-Output, Switch-Mode Current Source with Synchronous Rectifier

MAX1640/MAX1641

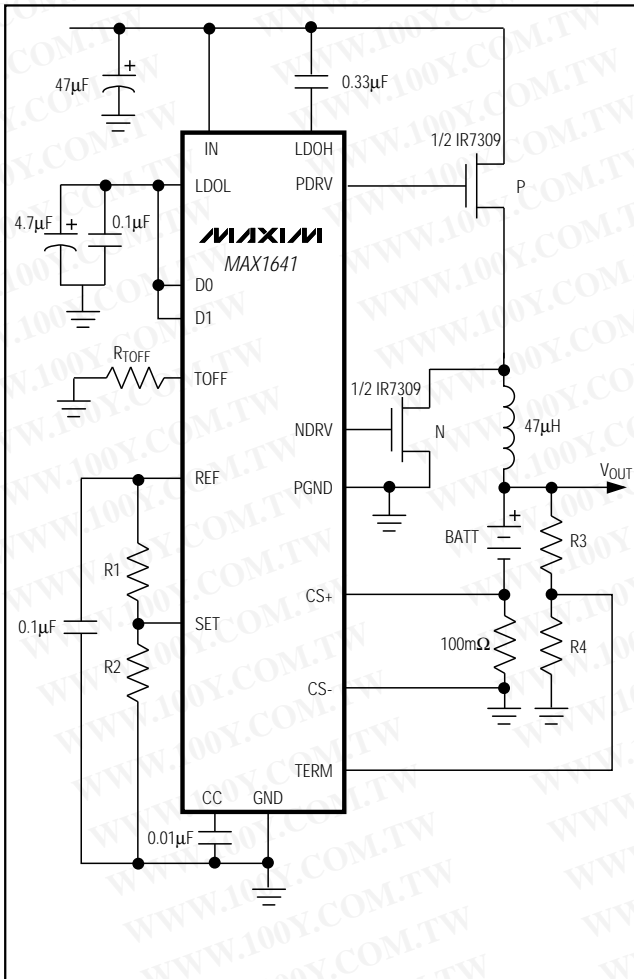

Figure 2a. Standard Application Circuit

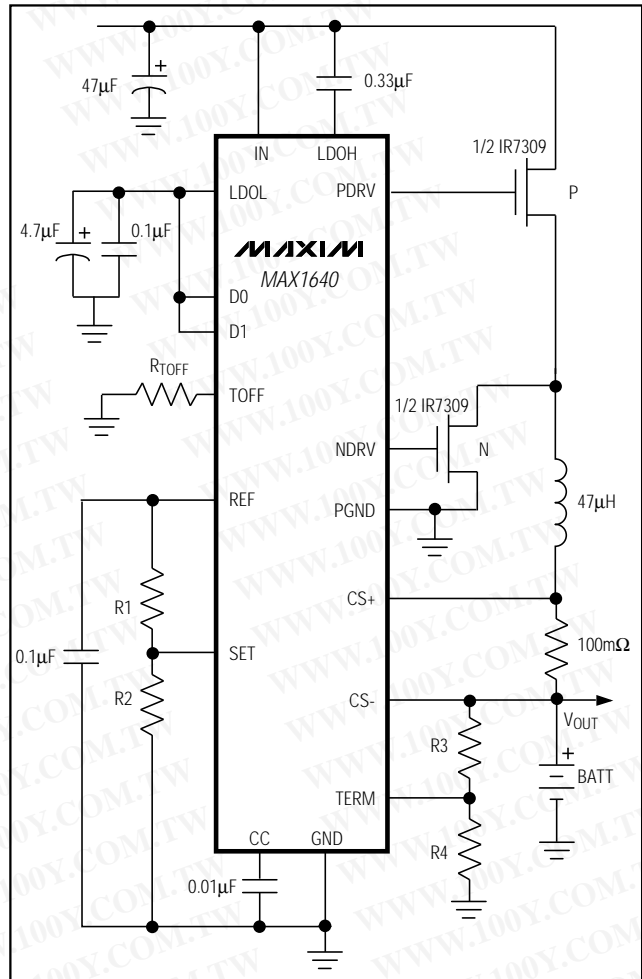

Figure 2b. Standard Application Circuit

Detailed Description

The MAX1640/MAX1641 switch-mode current sources utilize a hysteretic, current-mode, step-down pulse-width-modulation (PWM) topology with constant off-time. Internal comparators control the switching mechanism. These comparators monitor the current through a sense resistor (R_{SENSE}) and the voltage at TERM. When inductor current reaches the current limit $[(V_{CS+} - V_{CS-}) / R_{SENSE}]$, the P-channel FET turns off and the N-channel FET synchronous rectifier turns on. Inductor energy is delivered to the load as the current ramps down. This ramp rate depends on R_{TOFF} and inductor values. When off-time expires, the P-channel FET turns back on and the N-channel FET turns off.

Two digital inputs, D0 and D1, select between four possible current levels (Table 1). In pulse-trickle mode, the

part operates for 12.5% of the period set by R_{TOFF} , resulting in a lower current for pulse-trickle charging. Figure 1 is the MAX1640/MAX1641 functional diagram. Figure 2 shows the standard application circuits.

Charge Mode: Programming the Output Currents

The sense resistor, R_{SENSE} , sets two charging current levels. Choose between these two levels by holding D0 high, and toggling D1 either high or low (Table 1). The fast-charge current level equals V_{CS} / R_{SENSE} where V_{CS} is the full-scale current-sense voltage of 150mV. Alternatively, calculate this current by $V_{REF} / (13.3R_{SENSE})$. The top-off current equals $V_{SET} / (13.3R_{SENSE})$. A resistor-divider from REF to GND programs the voltage at SET (Figure 3).

Adjustable-Output, Switch-Mode Current Source with Synchronous Rectifier

The voltage at SET is given by:

$$R1 = R2 (V_{REF} / V_{SET} - 1); 10k\Omega < R2 < 300k\Omega$$

where $V_{REF} = 2V$ and V_{SET} is proportional to the desired output current level.

Table 1. Selecting Output Current Levels

D1	DO	MODE	OUTPUT CURRENT (A)
0	0	OFF	0
0	1	Top-Off	$V_{SET} / (13.3R_{SENSE})$
1	0	Pulse-Trickle	$V_{SET} / (13.3R_{SENSE})$ 12.5% duty cycle
1	1	Fast Charge	$V_{SET} / (13.3R_{SENSE})$

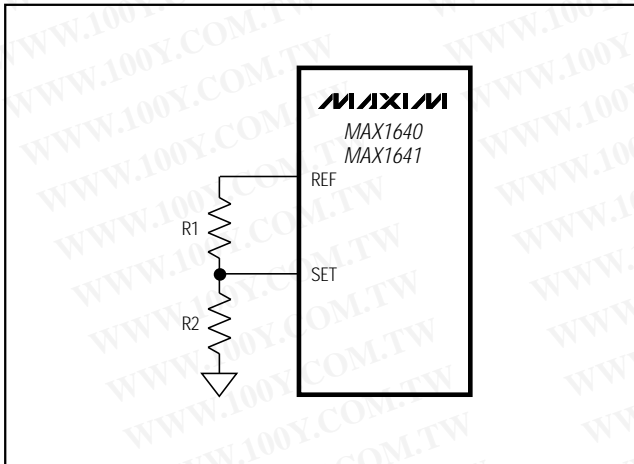

Figure 3. Adjusting the Output Current Level

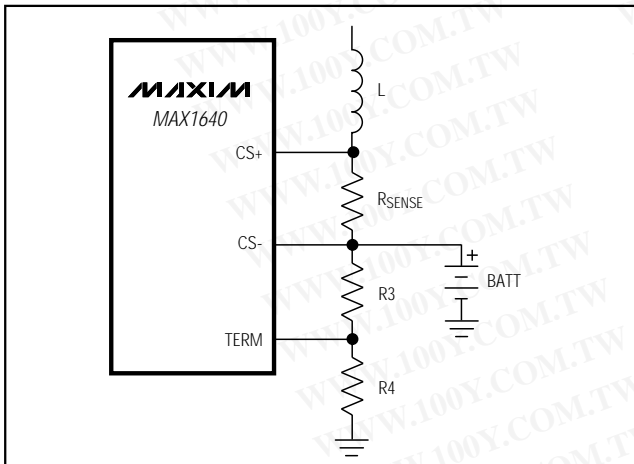

Figure 4a. Setting the Maximum Output Voltage Level

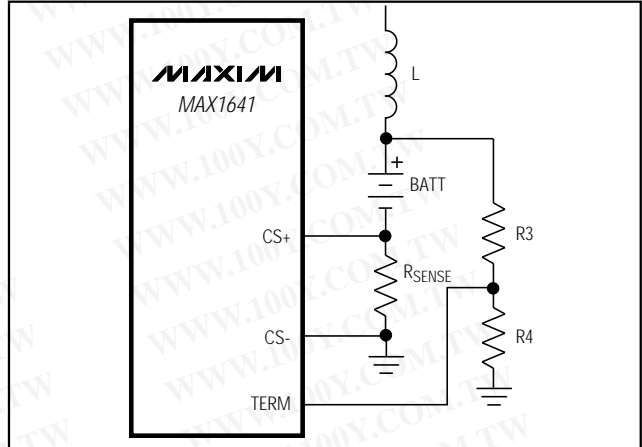

Figure 4b. Setting the Maximum Output Voltage Level

The MAX1640/MAX1641 are specified for V_{SET} between 0V and V_{REF} . For $V_{SET} > V_{REF}$, output current increases linearly (with reduced accuracy) until it clamps at $V_{SET} \approx 4V$.

Pulse-Trickle Mode: Selecting the Pulse-Trickle Current

Pulling D0 low and D1 high selects pulse-trickle mode. This current equals $V_{SET} / (13.3R_{SENSE})$ and remains on for 12.5% of the period set by R_{TOFF} . Pulse-trickle current maintains full charge across the battery and can slowly charge a cold battery before fast charging commences.

$$PERIOD = 3.2 \times 10^{-7} \times R_{TOFF}(\text{Sec})$$

Off Mode: Turning Off the Output Current

Pulling D0 and D1 low turns off the P-channel FET and hence the output current flow. This mode also controls end of charge and protects the battery against excessive temperatures.

Setting the Maximum Output Voltage Level

The maximum output voltage should be programmed to a level higher than the output/battery voltage ($I_{LOAD} \times R_{LOAD}$). An external resistor-divider between the output and ground (Figure 4) sets the voltage at TERM. Once the voltage at TERM exceeds the reference, the internal comparator turns off the P-channel FET, terminating current flow. Select R4 in the 10k Ω to 500k Ω range. R3 is given by:

$$R3 = R4 (V_{OUT} / V_{TERM}) - 1$$

Adjustable-Output, Switch-Mode Current Source with Synchronous Rectifier

MAX1640/MAX1641

where $V_{TERM} = 2V$ and V_{OUT} is the desired output voltage.

Programming the Off-Time

When programming the off-time, consider such factors as maximum inductor current ripple, maximum output voltage, inductor value, and inductor current rating. The output current ripple is less than the inductor current ripple and depends heavily on the output capacitor's size.

Perform the following steps to program the off-time:

- 1) Select the maximum output current ripple. $I_R(A)$
- 2) Select the maximum output voltage. $V_{OUT(MAX)}(V)$
- 3) Calculate the inductor value range as follows:
 $L_{MIN} = (V_{OUTMAX} \times 1\mu s) / I_R$
 $L_{MAX} = (V_{OUTMAX} \times 10\mu s) / I_R$
- 4) Select an inductor value in this range.
- 5) Calculate t_{OFF} as follows:

$$t_{OFF} = \frac{L \times I_R}{V_{OUTMAX}}$$

- 6) Program t_{OFF} by selecting R_{TOFF} from:

$$R_{TOFF} = (29.3 \times 10^9) \times t_{OFF}$$

- 7) Calculate the switching frequency by:

$$f_s = 1 / (t_{ON} + t_{OFF})$$

where $t_{ON} = (I_R \times L) / (V_{IN} - V_{OUT})$ and $I_R = (V_{OUT} \times t_{OFF}) / L$. L is the inductor value, V_{IN} is the input voltage, V_{OUT} is the output voltage, and I_R is the output peak-to-peak current ripple.

Note that R_{TOFF} sets both the off-time and the pulse-trickle charge period.

Reference

The on-chip reference is laser trimmed for a precise 2V at REF. REF can source no more than 50 μA . Bypass REF with a 0.1 μF capacitor to ground.

Constant-Current Loop: AC Loop Compensation

The constant-current loop's output is brought out at CC. To reduce noise due to variations in switching currents, bypass CC with a 1nF to 100nF capacitor to ground. A large capacitor value maintains a constant average output current but slows the loop response to changes in switching current. A small capacitor value speeds up the loop response to changes in switching current,

generating increased ripple at the output. Select C_{CC} to optimize the ripple vs. loop response.

Synchronous Rectification

Synchronous rectification reduces conduction losses in the rectifier by shunting the Schottky diode with a low-resistance MOSFET switch. In turn, efficiency increases by about 3% to 5% at heavy loads. To prevent cross-conduction or "shoot-through," the synchronous rectifier turns on shortly after the P-channel power MOSFET

Table 2. Component Manufacturers

COMPONENT	MANUFACTURER	
Inductor	Sumida	CDRH125 series
	Coilcraft	D03316P series
	Coiltronics	UP2 series
MOSFETs	International Rectifier	IRF7309
	Siliconix	S14539DY
Sense Resistor	Dale	WSL-2010 series
	IRC	LR2010-01 series
Capacitors	AVX	TPS series
	Sprague	595D series
Rectifier	Motorola	MBAR5340t3 IN5817-IN5822
	Nihon	NSQ03A04

turns off. The synchronous rectifier remains off for 90% of the off-time. In low-cost designs, the synchronous rectifier FET may be replaced by a Schottky diode.

Component Selection

External Switching Transistors

The MAX1640/MAX1641 drive an enhancement-mode P-channel MOSFET and a synchronous-rectifier N-channel MOSFET (Table 2).

When selecting a P-channel FET, some important parameters to consider are on-resistance ($r_{DS(ON)}$), maximum drain-to-source voltage ($V_{DS \max}$), maximum gate-to-source voltage ($V_{GS \max}$), and minimum threshold voltage ($V_{TH \min}$).

In high-current applications, MOSFET package power dissipation often becomes a dominant design factor. I^2R power losses are the greatest heat contributor for both high-side and low-side MOSFETs. Switching losses affect the upper MOSFET only (P-channel), since the Schottky rectifier or the N-FET body diode clamps the switching node before the synchronous rectifier turns on.

Rectifier Diode

If an N-channel MOSFET synchronous rectifier is not used, a Schottky rectifier is needed. The MAX1640/

Adjustable-Output, Switch-Mode Current Source with Synchronous Rectifier

configuration to PGND. These traces should be wide to reduce resistance and as short as possible to reduce stray inductance. All low-current ground paths should be connected to GND. Place the input bypass capacitor as close as possible to the IN pin. See MAX1640 EV kit for layout example.

Chip Information

TRANSISTOR COUNT: 1233

勝特力材料 886-3-5753170
 勝特力电子(上海) 86-21-54151736
 勝特力电子(深圳) 86-755-83298787
[Http://www.100y.com.tw](http://www.100y.com.tw)

Package Information

MAX1640/MAX1641

DIM	INCHES		MILLIMETERS	
	MIN	MAX	MIN	MAX
A	.061	.068	1.55	1.73
A1	.004	.0098	0.127	0.25
A2	.055	.061	1.40	1.55
B	.008	.012	0.20	0.31
C	.0075	.0098	0.19	0.25
D	SEE VARIATIONS			
E	.150	.157	3.81	3.99
e	.025 BSC		0.635 BSC	
H	.230	.244	5.84	6.20
h	.010	.016	0.25	0.41
L	.016	.035	0.41	0.89
N	SEE VARIATIONS			
S	SEE VARIATIONS			
?	0°	8°	0°	8°

VARIATIONS:

	INCHES		MILLIMETERS		N
	MIN.	MAX.	MIN.	MAX.	
D	.189	.196	4.80	4.98	16 AA
S	.0020	.0070	0.05	0.18	
D	.337	.344	8.56	8.74	20 AB
S	.0500	.0550	1.27	1.40	
D	.337	.344	8.56	8.74	24 AC
S	.0250	.0300	0.64	0.76	
D	.386	.393	9.80	9.98	28 AD
S	.0250	.0300	0.64	0.76	

NOTES:

- D & E DO NOT INCLUDE MOLD FLASH OR PROTRUSIONS
- MOLD FLASH OR PROTRUSIONS NOT TO EXCEED .006"
- CONTROLLING DIMENSIONS: INCHES

MAXIM
 PROPRIETARY INFORMATION
 TITLE: PACKAGE OUTLINE, QSOEP, .150 INCH, .025" LEAD PITCH
 APPROVAL: [] DOCUMENT CONTROL NO: 21-0055 REV: A 1/1