

# MC34063A, MC33063A, NCV33063A

## 1.5 A, Step-Up/Down/ Inverting Switching Regulators

The MC34063A Series is a monolithic control circuit containing the primary functions required for DC-to-DC converters. These devices consist of an internal temperature compensated reference, comparator, controlled duty cycle oscillator with an active current limit circuit, driver and high current output switch. This series was specifically designed to be incorporated in Step-Down and Step-Up and Voltage-Inverting applications with a minimum number of external components. Refer to Application Notes AN920A/D and AN954/D for additional design information.

- Operation from 3.0 V to 40 V Input
- Low Standby Current
- Current Limiting
- Output Switch Current to 1.5 A
- Output Voltage Adjustable
- Frequency Operation to 100 kHz
- Precision 2% Reference

勝特力材料 886-3-5753170  
 勝特力电子(上海) 86-21-54151736  
 勝特力电子(深圳) 86-755-83298787  
[Http://www.100y.com.tw](http://www.100y.com.tw)



ON Semiconductor®

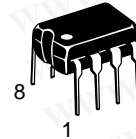

PDIP-8  
 P, P1 SUFFIX  
 CASE 626



SO-8  
 D SUFFIX  
 CASE 751

### PIN CONNECTIONS

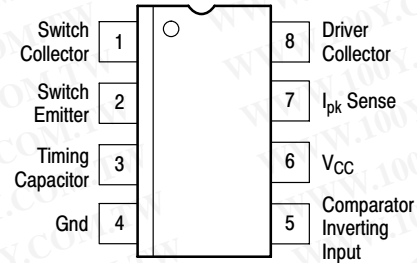

(Top View)

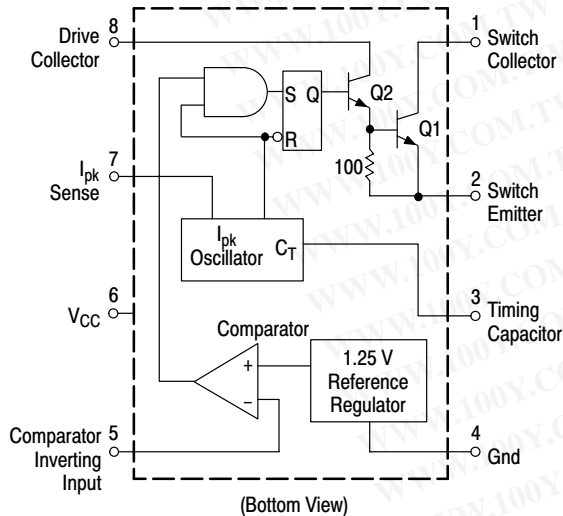

(Bottom View)

This device contains 51 active transistors.

Figure 1. Representative Schematic Diagram

### ORDERING INFORMATION

See detailed ordering and shipping information in the package dimensions section on page 11 of this data sheet.

### DEVICE MARKING INFORMATION

See general marking information in the device marking section on page 11 of this data sheet.

# MC34063A, MC33063A, NCV33063A

## MAXIMUM RATINGS

Rating	Symbol	Value	Unit
Power Supply Voltage	$V_{CC}$	40	Vdc
Comparator Input Voltage Range	$V_{IR}$	-0.3 to +40	Vdc
Switch Collector Voltage	$V_{C(\text{switch})}$	40	Vdc
Switch Emitter Voltage ( $V_{Pin\ 1} = 40\text{ V}$ )	$V_{E(\text{switch})}$	40	Vdc
Switch Collector to Emitter Voltage	$V_{CE(\text{switch})}$	40	Vdc
Driver Collector Voltage	$V_{C(\text{driver})}$	40	Vdc
Driver Collector Current (Note 1)	$I_{C(\text{driver})}$	100	mA
Switch Current	$I_{SW}$	1.5	A
Power Dissipation and Thermal Characteristics			
Plastic Package, P, P1 Suffix $T_A = 25^\circ\text{C}$ Thermal Resistance	$P_D$ $R_{\theta JA}$	1.25 100	W $^\circ\text{C/W}$
SOIC Package, D Suffix $T_A = 25^\circ\text{C}$ Thermal Resistance	$P_D$ $R_{\theta JA}$	625 160	mW $^\circ\text{C/W}$
Operating Junction Temperature	$T_J$	+150	$^\circ\text{C}$
Operating Ambient Temperature Range MC34063A MC33063AV, NCV33063A MC33063A	$T_A$	0 to +70 -40 to +125 -40 to +85	$^\circ\text{C}$
Storage Temperature Range	$T_{stg}$	-65 to +150	$^\circ\text{C}$

1. Maximum package power dissipation limits must be observed.
2. ESD data available upon request.
3. NCV prefix is for automotive and other applications requiring site and change control.

**勝特力材料 886-3-5753170**  
**勝特力电子(上海) 86-21-54151736**  
**勝特力电子(深圳) 86-755-83298787**  
[Http://www.100y.com.tw](http://www.100y.com.tw)

# MC34063A, MC33063A, NCV33063A

## ELECTRICAL CHARACTERISTICS ( $V_{CC} = 5.0\text{ V}$ , $T_A = T_{low}$ to $T_{high}$ [Note 4], unless otherwise specified.)

Characteristics	Symbol	Min	Typ	Max	Unit
-----------------	--------	-----	-----	-----	------

### OSCILLATOR

Frequency ( $V_{Pin5} = 0\text{ V}$ , $C_T = 1.0\text{ nF}$ , $T_A = 25^\circ\text{C}$ )	$f_{osc}$	24	33	42	kHz
Charge Current ( $V_{CC} = 5.0\text{ V to } 40\text{ V}$ , $T_A = 25^\circ\text{C}$ )	$I_{chg}$	24	35	42	$\mu\text{A}$
Discharge Current ( $V_{CC} = 5.0\text{ V to } 40\text{ V}$ , $T_A = 25^\circ\text{C}$ )	$I_{dischg}$	140	220	260	$\mu\text{A}$
Discharge to Charge Current Ratio (Pin 7 to $V_{CC}$ , $T_A = 25^\circ\text{C}$ )	$I_{dischg}/I_{chg}$	5.2	6.5	7.5	–
Current Limit Sense Voltage ( $I_{chg} = I_{dischg}$ , $T_A = 25^\circ\text{C}$ )	$V_{ipk(sense)}$	250	300	350	mV

### OUTPUT SWITCH (Note 5)

Saturation Voltage, Darlington Connection ( $I_{SW} = 1.0\text{ A}$ , Pins 1, 8 connected)	$V_{CE(sat)}$	–	1.0	1.3	V
Saturation Voltage (Note 6) ( $I_{SW} = 1.0\text{ A}$ , $R_{Pin8} = 82\ \Omega$ to $V_{CC}$ , Forced $\beta \approx 20$ )	$V_{CE(sat)}$	–	0.45	0.7	V
DC Current Gain ( $I_{SW} = 1.0\text{ A}$ , $V_{CE} = 5.0\text{ V}$ , $T_A = 25^\circ\text{C}$ )	$h_{FE}$	50	75	–	–
Collector Off-State Current ( $V_{CE} = 40\text{ V}$ )	$I_{C(off)}$	–	0.01	100	$\mu\text{A}$

### COMPARATOR

Threshold Voltage $T_A = 25^\circ\text{C}$ $T_A = T_{low}$ to $T_{high}$	$V_{th}$	1.225 1.21	1.25 –	1.275 1.29	V
Threshold Voltage Line Regulation ( $V_{CC} = 3.0\text{ V to } 40\text{ V}$ ) MC33063A, MC34063A MC33063AV, NCV33063A	$Reg_{line}$	– –	1.4 1.4	5.0 6.0	mV
Input Bias Current ( $V_{in} = 0\text{ V}$ )	$I_{IB}$	–	–20	–400	nA

### TOTAL DEVICE

Supply Current ( $V_{CC} = 5.0\text{ V to } 40\text{ V}$ , $C_T = 1.0\text{ nF}$ , Pin 7 = $V_{CC}$ , $V_{Pin5} > V_{th}$ , Pin 2 = Gnd, remaining pins open)	$I_{CC}$	–	–	4.0	mA
--	----------	---	---	-----	----

- $T_{low} = 0^\circ\text{C}$  for MC34063A,  $-40^\circ\text{C}$  for MC33063A, AV, NCV33063A  
 $T_{high} = +70^\circ\text{C}$  for MC34063A,  $+85^\circ\text{C}$  for MC33063A,  $+125^\circ\text{C}$  for MC33063AV, NCV33063A
- Low duty cycle pulse techniques are used during test to maintain junction temperature as close to ambient temperature as possible.
- If the output switch is driven into hard saturation (non-Darlington configuration) at low switch currents ( $\leq 300\text{ mA}$ ) and high driver currents ( $\geq 30\text{ mA}$ ), it may take up to  $2.0\ \mu\text{s}$  for it to come out of saturation. This condition will shorten the off time at frequencies  $\geq 30\text{ kHz}$ , and is magnified at high temperatures. This condition does not occur with a Darlington configuration, since the output switch cannot saturate. If a non-Darlington configuration is used, the following output drive condition is recommended:

$$\text{Forced } \beta \text{ of output switch : } \frac{I_C \text{ output}}{I_C \text{ driver} - 7.0\text{ mA}^*} \geq 10$$

\* The  $100\ \Omega$  resistor in the emitter of the driver device requires about  $7.0\text{ mA}$  before the output switch conducts.

勝特力材料 886-3-5753170  
 勝特力电子(上海) 86-21-54151736  
 勝特力电子(深圳) 86-755-83298787  
[Http://www.100y.com.tw](http://www.100y.com.tw)

# MC34063A, MC33063A, NCV33063A

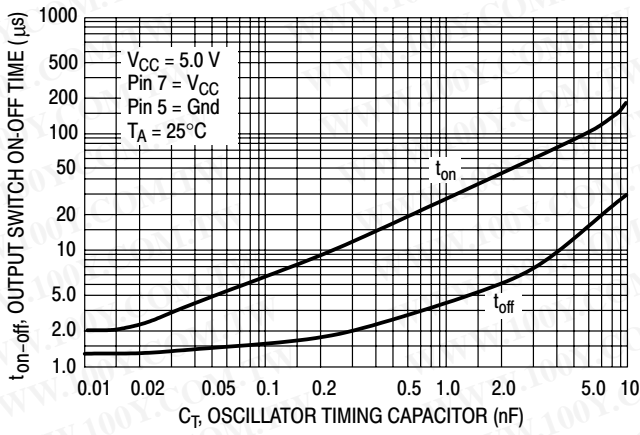

**Figure 2. Output Switch On-Off Time versus Oscillator Timing Capacitor**

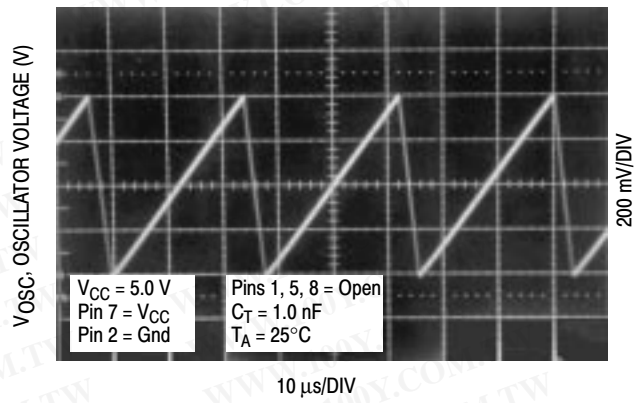

**Figure 3. Timing Capacitor Waveform**

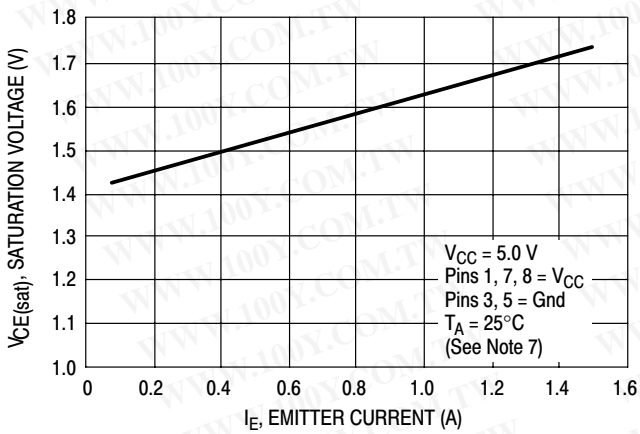

**Figure 4. Emitter Follower Configuration Output Saturation Voltage versus Emitter Current**

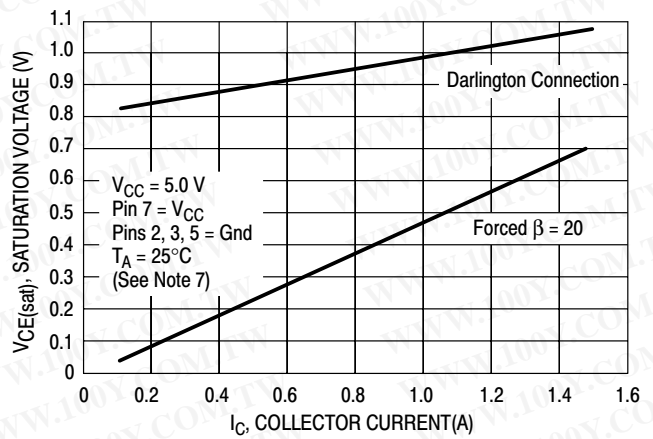

**Figure 5. Common Emitter Configuration Output Switch Saturation Voltage versus Collector Current**

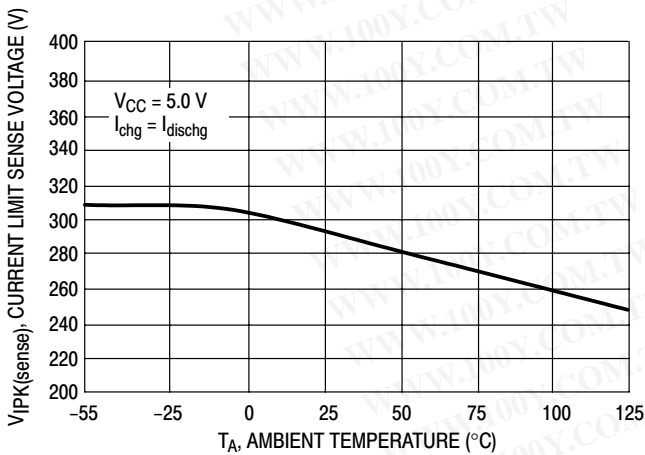

**Figure 6. Current Limit Sense Voltage versus Temperature**

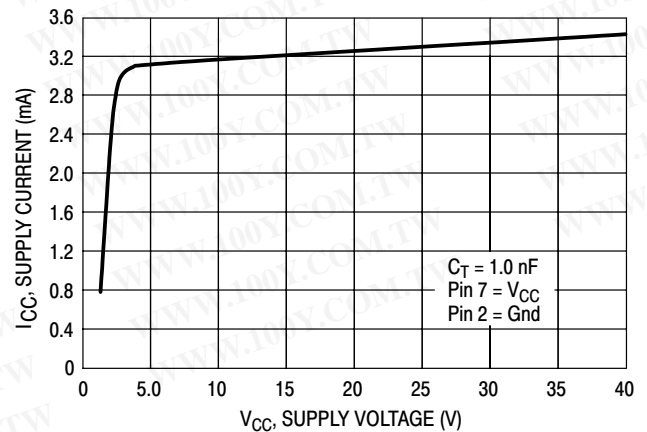
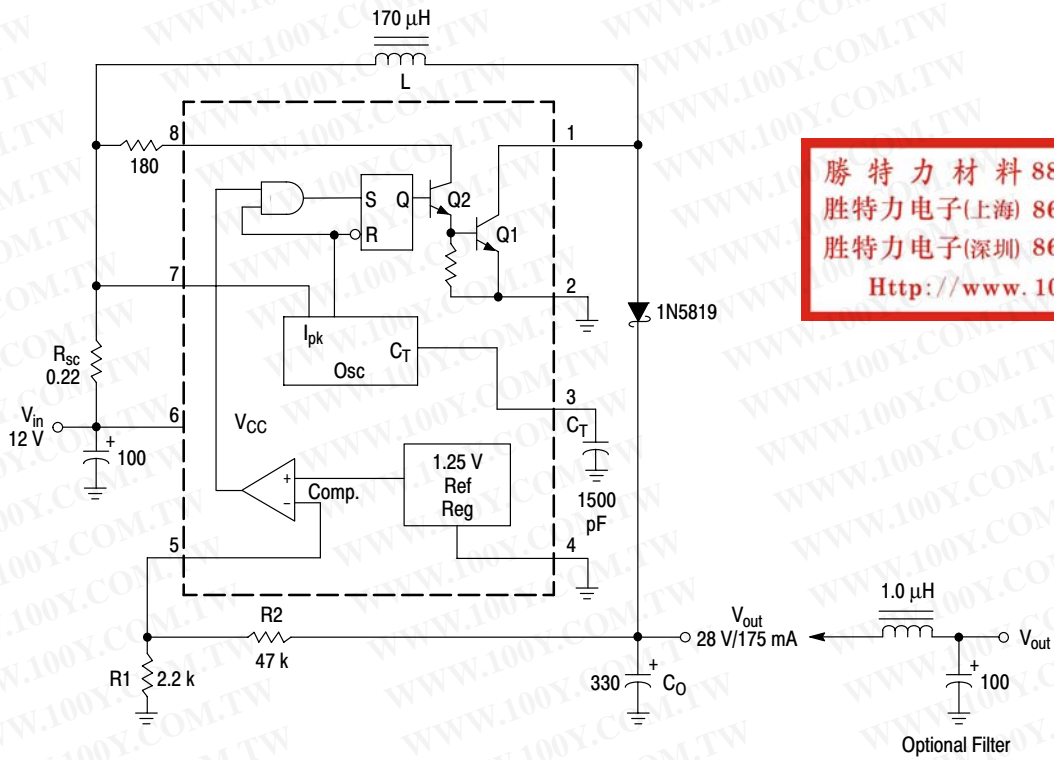

**Figure 7. Standby Supply Current versus Supply Voltage**

7. Low duty cycle pulse techniques are used during test to maintain junction temperature as close to ambient temperature as possible.

勝特力材料 886-3-5753170  
 勝特力电子(上海) 86-21-54151736  
 勝特力电子(深圳) 86-755-83298787  
[Http://www.100y.com.tw](http://www.100y.com.tw)

# MC34063A, MC33063A, NCV33063A



勝特力材料 886-3-5753170  
 勝特力电子(上海) 86-21-54151736  
 勝特力电子(深圳) 86-755-83298787  
[Http://www.100y.com.tw](http://www.100y.com.tw)

Test	Conditions	Results
Line Regulation	$V_{in} = 8.0 \text{ V to } 16 \text{ V}, I_O = 175 \text{ mA}$	30 mV = $\pm 0.05\%$
Load Regulation	$V_{in} = 12 \text{ V}, I_O = 75 \text{ mA to } 175 \text{ mA}$	10 mV = $\pm 0.017\%$
Output Ripple	$V_{in} = 12 \text{ V}, I_O = 175 \text{ mA}$	400 mVpp
Efficiency	$V_{in} = 12 \text{ V}, I_O = 175 \text{ mA}$	87.7%
Output Ripple With Optional Filter	$V_{in} = 12 \text{ V}, I_O = 175 \text{ mA}$	40 mVpp

Figure 8. Step-Up Converter



# MC34063A, MC33063A, NCV33063A

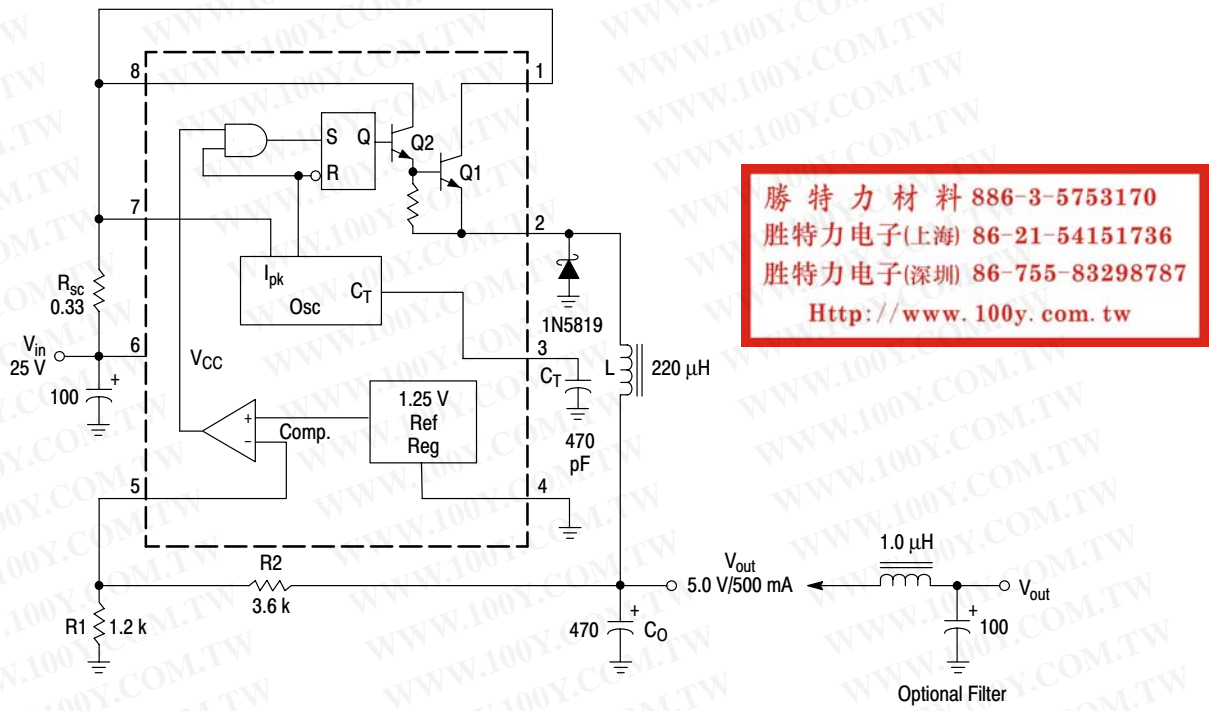

勝特力材料 886-3-5753170  
 勝特力电子(上海) 86-21-54151736  
 勝特力电子(深圳) 86-755-83298787  
[Http://www.100y.com.tw](http://www.100y.com.tw)

Test	Conditions	Results
Line Regulation	$V_{in} = 15\text{ V to }25\text{ V}, I_O = 500\text{ mA}$	$12\text{ mV} = \pm 0.12\%$
Load Regulation	$V_{in} = 25\text{ V}, I_O = 50\text{ mA to }500\text{ mA}$	$3.0\text{ mV} = \pm 0.03\%$
Output Ripple	$V_{in} = 25\text{ V}, I_O = 500\text{ mA}$	$120\text{ mVpp}$
Short Circuit Current	$V_{in} = 25\text{ V}, R_L = 0.1\ \Omega$	$1.1\text{ A}$
Efficiency	$V_{in} = 25\text{ V}, I_O = 500\text{ mA}$	$83.7\%$
Output Ripple With Optional Filter	$V_{in} = 25\text{ V}, I_O = 500\text{ mA}$	$40\text{ mVpp}$

Figure 10. Step-Down Converter

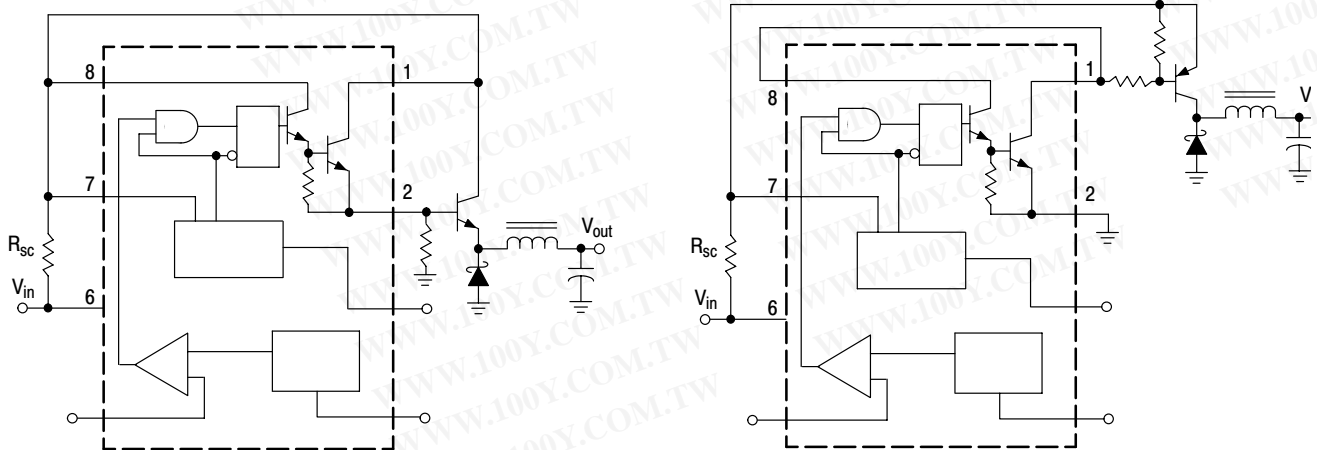
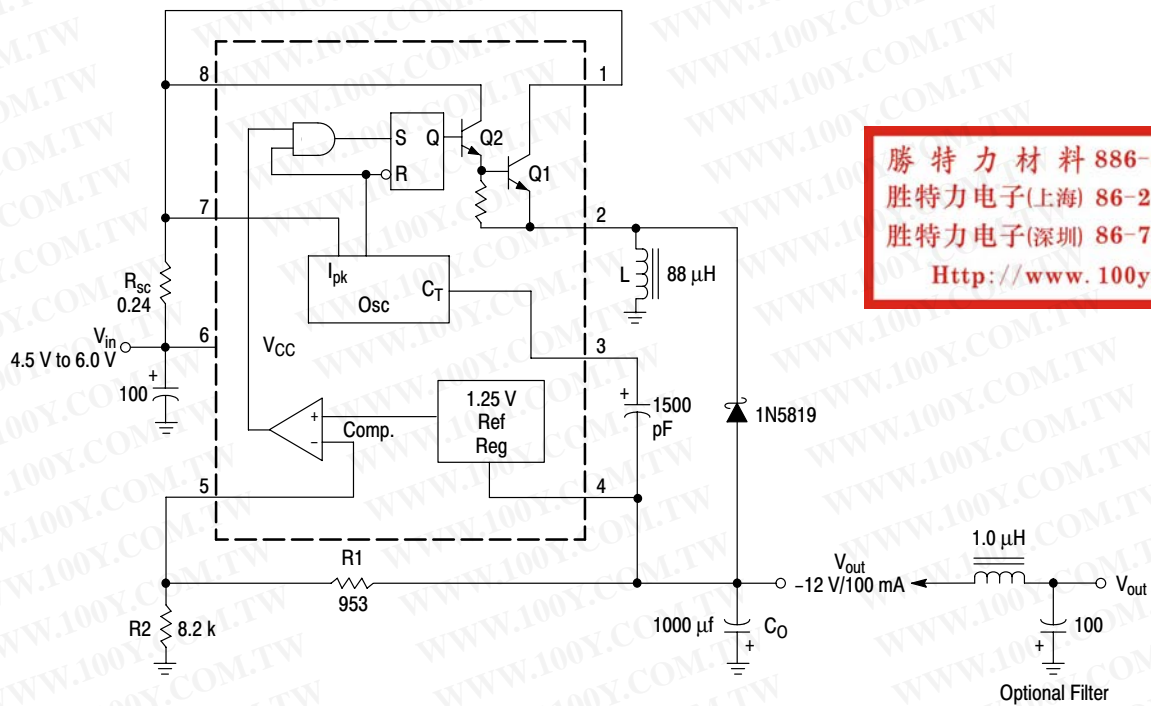

Figure 11. External Current Boost Connections for  $I_C$  Peak Greater than 1.5 A

11a. External NPN Switch

11b. External PNP Saturated Switch

# MC34063A, MC33063A, NCV33063A



勝特力材料 886-3-5753170  
 勝特力电子(上海) 86-21-54151736  
 勝特力电子(深圳) 86-755-83298787  
[Http://www.100y.com.tw](http://www.100y.com.tw)

Test	Conditions	Results
Line Regulation	$V_{in} = 4.5\text{ V to }6.0\text{ V}, I_O = 100\text{ mA}$	3.0 mV = $\pm 0.012\%$
Load Regulation	$V_{in} = 5.0\text{ V}, I_O = 10\text{ mA to }100\text{ mA}$	0.022 V = $\pm 0.09\%$
Output Ripple	$V_{in} = 5.0\text{ V}, I_O = 100\text{ mA}$	500 mVpp
Short Circuit Current	$V_{in} = 5.0\text{ V}, R_L = 0.1\ \Omega$	910 mA
Efficiency	$V_{in} = 5.0\text{ V}, I_O = 100\text{ mA}$	62.2%
Output Ripple With Optional Filter	$V_{in} = 5.0\text{ V}, I_O = 100\text{ mA}$	70 mVpp

Figure 12. Voltage Inverting Converter

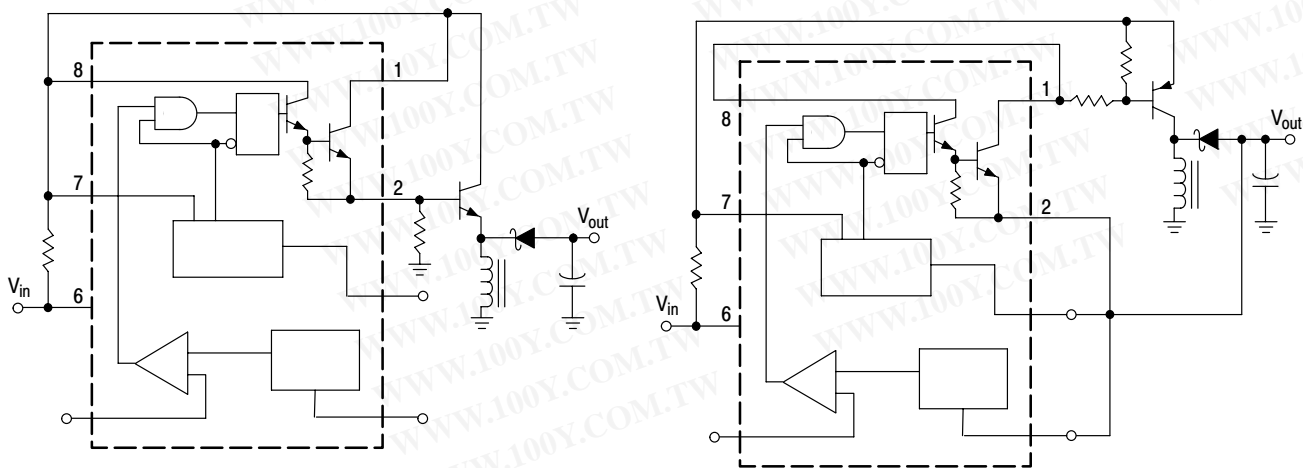

Figure 13. External Current Boost Connections for  $I_C$  Peak Greater than 1.5 A

13a. External NPN Switch

13b. External PNP Saturated Switch



# MC34063A, MC33063A, NCV33063A

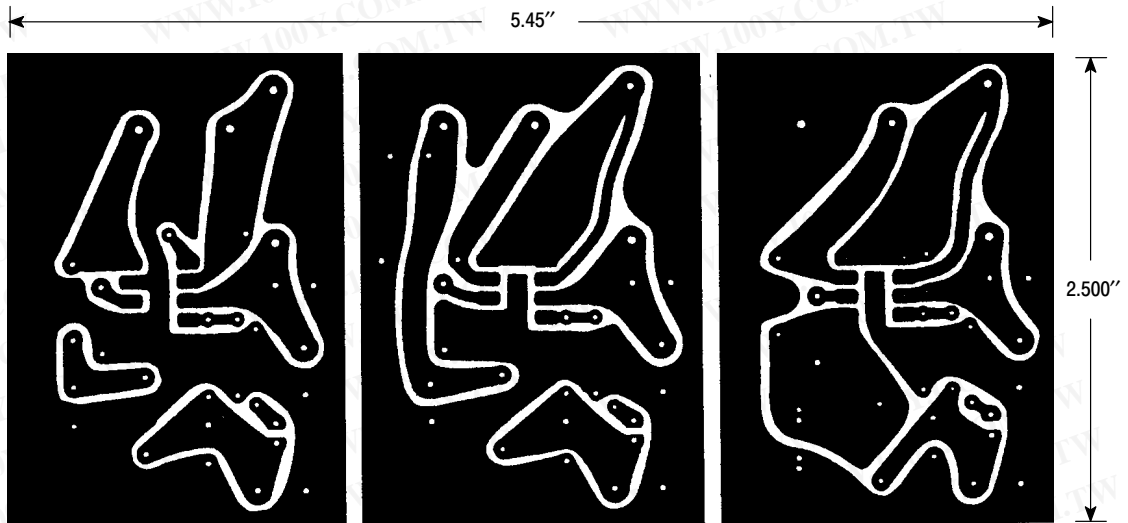

(Top view, copper foil as seen through the board from the component side)

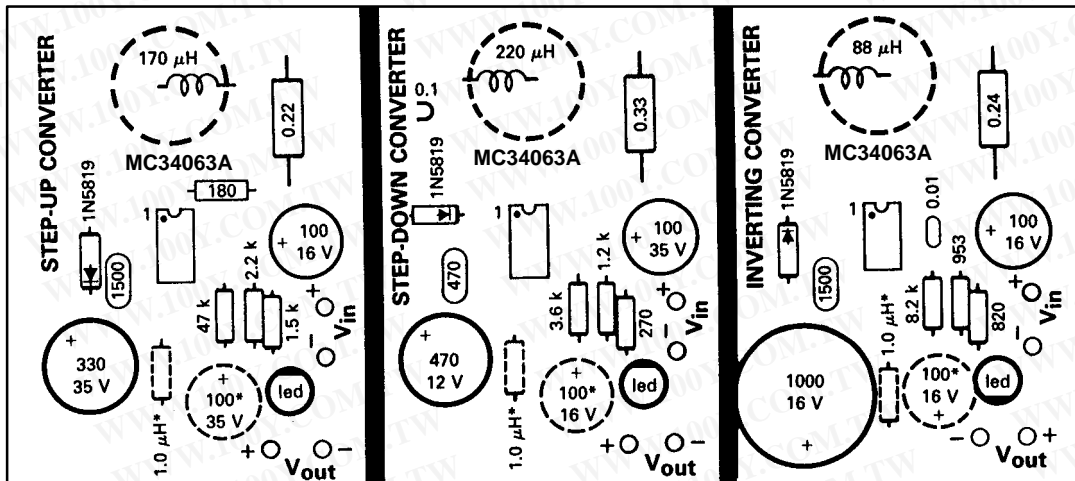

(Top View, Component Side)

\*Optional Filter.

**Figure 14. Printed Circuit Board and Component Layout**

(Circuits of Figures 8, 10, 12)

## INDUCTOR DATA

Converter	Inductance ( $\mu\text{H}$ )	Turns/Wire
Step-Up	170	38 Turns of #22 AWG
Step-Down	220	48 Turns of #22 AWG
Voltage-Inverting	88	28 Turns of #22 AWG

All inductors are wound on Magnetics Inc. 55117 toroidal core.

勝特力材料 886-3-5753170  
 勝特力电子(上海) 86-21-54151736  
 勝特力电子(深圳) 86-755-83298787  
[Http://www.100y.com.tw](http://www.100y.com.tw)

## MC34063A, MC33063A, NCV33063A

Calculation	Step-Up	Step-Down	Voltage-Inverting
$t_{on}/t_{off}$	$\frac{V_{out} + V_F - V_{in(min)}}{V_{in(min)} - V_{sat}}$	$\frac{V_{out} + V_F}{V_{in(min)} - V_{sat} - V_{out}}$	$\frac{ V_{out}  + V_F}{V_{in} - V_{sat}}$
$(t_{on} + t_{off})$	$\frac{1}{f}$	$\frac{1}{f}$	$\frac{1}{f}$
$t_{off}$	$\frac{t_{on} + t_{off}}{\frac{t_{on}}{t_{off}} + 1}$	$\frac{t_{on} + t_{off}}{\frac{t_{on}}{t_{off}} + 1}$	$\frac{t_{on} + t_{off}}{\frac{t_{on}}{t_{off}} + 1}$
$t_{on}$	$(t_{on} + t_{off}) - t_{off}$	$(t_{on} + t_{off}) - t_{off}$	$(t_{on} + t_{off}) - t_{off}$
$C_T$	$4.0 \times 10^{-5} t_{on}$	$4.0 \times 10^{-5} t_{on}$	$4.0 \times 10^{-5} t_{on}$
$I_{pk( switch )}$	$2I_{out(max)} \left( \frac{t_{on}}{t_{off}} + 1 \right)$	$2I_{out(max)}$	$2I_{out(max)} \left( \frac{t_{on}}{t_{off}} + 1 \right)$
$R_{sc}$	$0.3/I_{pk( switch )}$	$0.3/I_{pk( switch )}$	$0.3/I_{pk( switch )}$
$L_{(min)}$	$\left( \frac{V_{in(min)} - V_{sat}}{I_{pk( switch )}} \right) t_{on(max)}$	$\left( \frac{V_{in(min)} - V_{sat} - V_{out}}{I_{pk( switch )}} \right) t_{on(max)}$	$\left( \frac{V_{in(min)} - V_{sat}}{I_{pk( switch )}} \right) t_{on(max)}$
$C_O$	$9 \frac{I_{out} t_{on}}{V_{ripple(pp)}}$	$\frac{I_{pk( switch )} (t_{on} + t_{off})}{8V_{ripple(pp)}}$	$9 \frac{I_{out} t_{on}}{V_{ripple(pp)}}$

$V_{sat}$  = Saturation voltage of the output switch.  
 $V_F$  = Forward voltage drop of the output rectifier.

**The following power supply characteristics must be chosen:**

$V_{in}$  – Nominal input voltage.

$V_{out}$  – Desired output voltage,  $|V_{out}| = 1.25 \left( 1 + \frac{R_2}{R_1} \right)$

$I_{out}$  – Desired output current.

$f_{min}$  – Minimum desired output switching frequency at the selected values of  $V_{in}$  and  $I_O$ .

$V_{ripple(pp)}$  – Desired peak-to-peak output ripple voltage. In practice, the calculated capacitor value will need to be increased due to its equivalent series resistance and board layout. The ripple voltage should be kept to a low value since it will directly affect the line and load regulation.

**NOTE:** For further information refer to Application Note AN920A/D and AN954/D.

**Figure 15. Design Formula Table**

勝特力材料 886-3-5753170  
 勝特力电子(上海) 86-21-54151736  
 勝特力电子(深圳) 86-755-83298787  
[Http://www.100y.com.tw](http://www.100y.com.tw)

# MC34063A, MC33063A, NCV33063A

## ORDERING INFORMATION

Device	Package	Shipping
MC33063AD	SO-8	98 Units / Rail
MC33063ADR2	SO-8	2500 Units / Tape & Reel
MC33063AP1	DIP-8	50 Units / Rail
MC33063AVD	SO-8	98 Units / Rail
MC33063AVDR2	SO-8	2500 Units / Tape & Reel
NCV33063AVDR2*	SO-8	2500 Units / Tape & Reel
MC33063AVP	DIP-8	50 Units / Rail
MC34063AD	SO-8	98 Units / Rail
MC34063ADR2	SO-8	2500 Units / Tape & Reel
MC34063AP1	DIP-8	50 Units / Rail

\*NCV33063A:  $T_{low} = -40^{\circ}C$ ,  $T_{high} = +125^{\circ}C$ . Guaranteed by design. NCV prefix is for automotive and other applications requiring site and change control.

## MARKING DIAGRAMS

PDIP-8  
P, P1 SUFFIX  
CASE 626

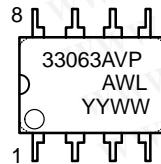
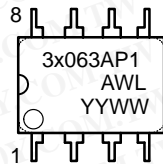

SO-8  
D SUFFIX  
CASE 751

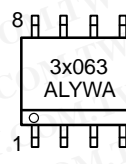

x = 3 or 4  
A = Assembly Location  
WL, L = Wafer Lot  
YY, Y = Year  
WW, W = Work Week

勝特力材料 886-3-5753170  
勝特力电子(上海) 86-21-54151736  
勝特力电子(深圳) 86-755-83298787  
[Http://www.100y.com.tw](http://www.100y.com.tw)

# MC34063A, MC33063A, NCV33063A

## PACKAGE DIMENSIONS

PDIP-8  
P, P1 SUFFIX  
PLASTIC PACKAGE  
CASE 626-05  
ISSUE L

勝特力材料 886-3-5753170  
勝特力电子(上海) 86-21-54151736  
勝特力电子(深圳) 86-755-83298787  
[Http://www.100y.com.tw](http://www.100y.com.tw)

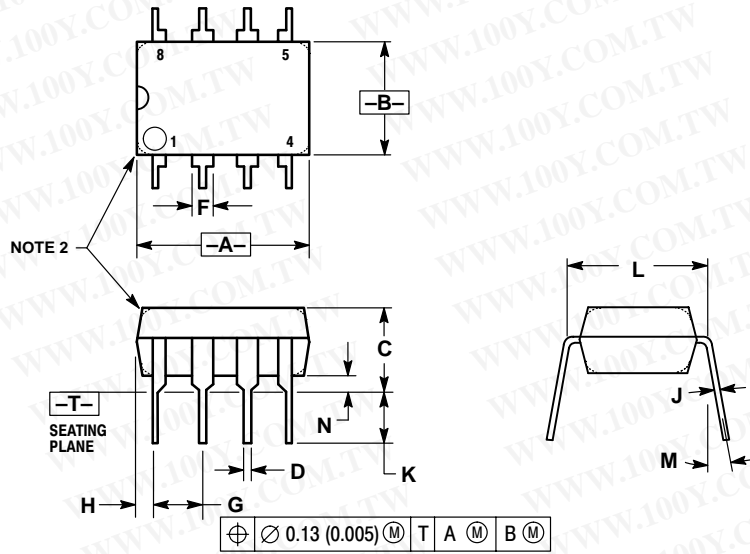

### NOTES:

1. DIMENSION L TO CENTER OF LEAD WHEN FORMED PARALLEL.
2. PACKAGE CONTOUR OPTIONAL (ROUND OR SQUARE CORNERS).
3. DIMENSIONING AND TOLERANCING PER ANSI Y14.5M, 1982.

DIM	MILLIMETERS		INCHES	
	MIN	MAX	MIN	MAX
A	9.40	10.16	0.370	0.400
B	6.10	6.60	0.240	0.260
C	3.94	4.45	0.155	0.175
D	0.38	0.51	0.015	0.020
F	1.02	1.78	0.040	0.070
G	2.54 BSC		0.100 BSC	
H	0.76	1.27	0.030	0.050
J	0.20	0.30	0.008	0.012
K	2.92	3.43	0.115	0.135
L	7.62 BSC		0.300 BSC	
M	---	10°	---	10°
N	0.76	1.01	0.030	0.040

# MC34063A, MC33063A, NCV33063A

## PACKAGE DIMENSIONS

SO-8  
D SUFFIX  
PLASTIC PACKAGE  
CASE 751-07  
ISSUE W

勝特力材料 886-3-5753170  
 勝特力电子(上海) 86-21-54151736  
 勝特力电子(深圳) 86-755-83298787  
[Http://www.100y.com.tw](http://www.100y.com.tw)

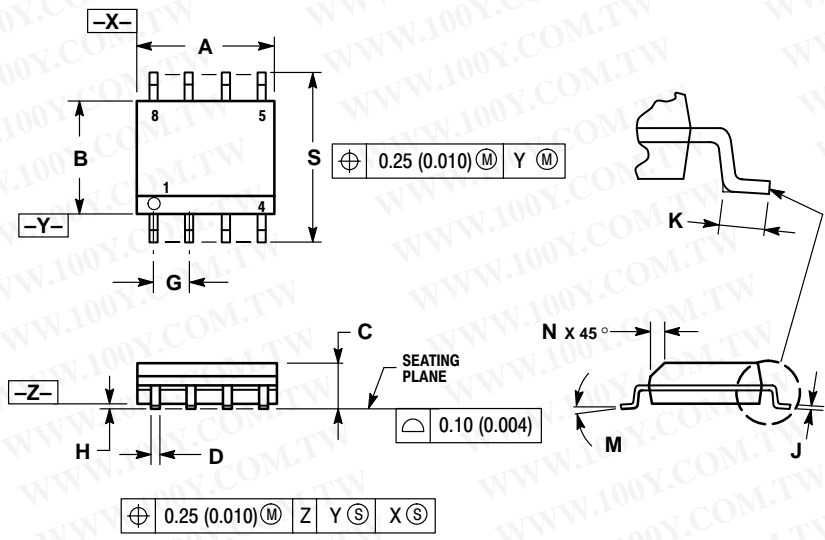

- NOTES:
1. DIMENSIONING AND TOLERANCING PER ANSI Y14.5M, 1982.
  2. CONTROLLING DIMENSION: MILLIMETER.
  3. DIMENSION A AND B DO NOT INCLUDE MOLD PROTRUSION.
  4. MAXIMUM MOLD PROTRUSION 0.15 (0.006) PER SIDE.
  5. DIMENSION D DOES NOT INCLUDE DAMBAR PROTRUSION. ALLOWABLE DAMBAR PROTRUSION SHALL BE 0.127 (0.005) TOTAL IN EXCESS OF THE D DIMENSION AT MAXIMUM MATERIAL CONDITION.

DIM	MILLIMETERS		INCHES	
	MIN	MAX	MIN	MAX
A	4.80	5.00	0.189	0.197
B	3.80	4.00	0.150	0.157
C	1.35	1.75	0.053	0.069
D	0.33	0.51	0.013	0.020
G	1.27 BSC		0.050 BSC	
H	0.10	0.25	0.004	0.010
J	0.19	0.25	0.007	0.010
K	0.40	1.27	0.016	0.050
M	0°	8°	0°	8°
N	0.25	0.50	0.010	0.020
S	5.80	6.20	0.228	0.244