



勝特力材料 886-3-5753170
 勝特力电子(上海) 86-21-54151736
 勝特力电子(深圳) 86-755-83298787
[Http://www.100y.com.tw](http://www.100y.com.tw)

Order this document by MC3403/D

MC3403 MC3303

Quad Low Power Operational Amplifiers

The MC3403 is a low cost, quad operational amplifier with true differential inputs. The device has electrical characteristics similar to the popular MC1741C. However, the MC3403 has several distinct advantages over standard operational amplifier types in single supply applications. The quad amplifier can operate at supply voltages as low as 3.0 V or as high as 36 V with quiescent currents about one third of those associated with the MC1741C (on a per amplifier basis). The common mode input range includes the negative supply, thereby eliminating the necessity for external biasing components in many applications. The output voltage range also includes the negative power supply voltage.

- Short Circuit Protected Outputs
- Class AB Output Stage for Minimal Crossover Distortion
- True Differential Input Stage
- Single Supply Operation: 3.0 V to 36 V
- Split Supply Operation: ± 1.5 V to ± 18 V
- Low Input Bias Currents: 500 nA Max
- Four Amplifiers Per Package
- Internally Compensated
- Similar Performance to Popular MC1741C
- Industry Standard Pinouts
- ESD Diodes Added for Increased Ruggedness

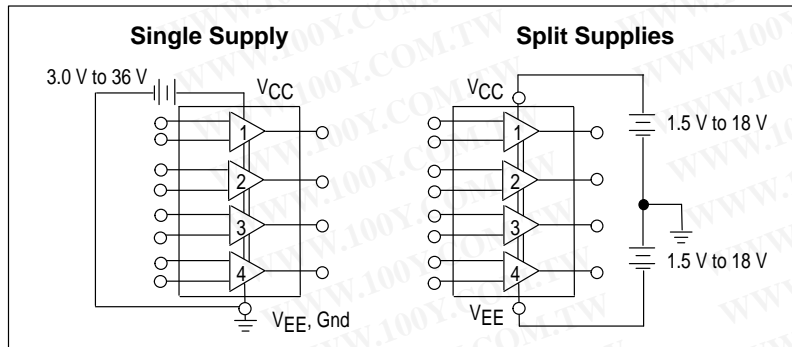

MAXIMUM RATINGS

Rating	Symbol	Value	Unit
Power Supply Voltages			Vdc
Single Supply	V_{CC}	36	
Split Supplies	V_{CC}, V_{EE}	± 18	
Input Differential Voltage Range (Note 1)	V_{IDR}	± 36	Vdc
Input Common Mode Voltage Range (Notes 1, 2)	V_{ICR}	± 18	Vdc
Storage Temperature Range	T_{stg}	-55 to +125	$^{\circ}C$
Operating Ambient Temperature Range	T_A		$^{\circ}C$
MC3303		-40 to +85	
MC3403		0 to +70	
Junction Temperature	T_J	150	$^{\circ}C$

NOTES: 1. Split power supplies.
 2. For supply voltages less than ± 18 V, the absolute maximum input voltage is equal to the supply voltage.

QUAD DIFFERENTIAL INPUT OPERATIONAL AMPLIFIERS

SEMICONDUCTOR TECHNICAL DATA



D SUFFIX
 PLASTIC PACKAGE
 CASE 751A
 (SO-14)

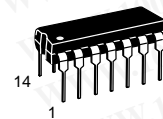

P SUFFIX
 PLASTIC PACKAGE
 CASE 646

PIN CONNECTIONS

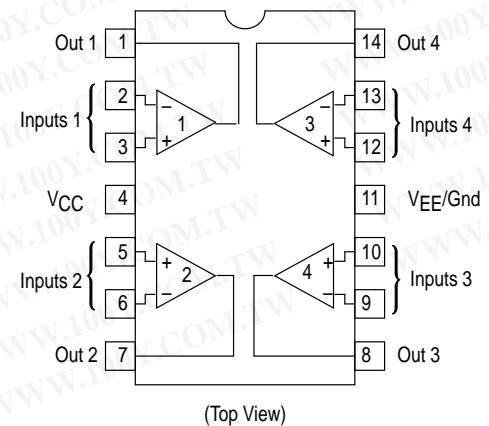

ORDERING INFORMATION

Device	Operating Temperature Range	Package
MC3303D MC3303P	$T_A = -40^{\circ}$ to $+85^{\circ}C$	SO-14 Plastic DIP
MC3403D MC3403P	$T_A = 0^{\circ}$ to $+70^{\circ}C$	SO-14 Plastic DIP

MC3403 MC3303

ELECTRICAL CHARACTERISTICS ($V_{CC} = +15\text{ V}$, $V_{EE} = -15\text{ V}$ for MC3403; $V_{CC} = +14\text{ V}$, $V_{EE} = \text{Gnd}$ for MC3303
 $T_A = 25^\circ\text{C}$, unless otherwise noted.)

Characteristic	Symbol	MC3403			MC3303			Unit
		Min	Typ	Max	Min	Typ	Max	
Input Offset Voltage $T_A = T_{\text{high}}$ to T_{low} (Note 1)	V_{IO}	–	2.0	10	–	2.0	8.0	mV
		–	–	12	–	–	10	
Input Offset Current $T_A = T_{\text{high}}$ to T_{low}	I_{IO}	–	30	50	–	30	75	nA
		–	–	200	–	–	250	
Large Signal Open Loop Voltage Gain $V_O = \pm 10\text{ V}$, $R_L = 2.0\text{ k}\Omega$ $T_A = T_{\text{high}}$ to T_{low}	A_{VOL}	20	200	–	20	200	–	V/mV
		15	–	–	15	–	–	
Input Bias Current $T_A = T_{\text{high}}$ to T_{low}	I_{IB}	–	–200	–500	–	–200	–500	nA
		–	–	–800	–	–	–1000	
Output Impedance $f = 20\text{ Hz}$	z_o	–	75	–	–	75	–	Ω
Input Impedance $f = 20\text{ Hz}$	z_i	0.3	1.0	–	0.3	1.0	–	M Ω
Output Voltage Range $R_L = 10\text{ k}\Omega$ $R_L = 2.0\text{ k}\Omega$ $R_L = 2.0\text{ k}\Omega$, $T_A = T_{\text{high}}$ to T_{low}	V_O	± 12	± 13.5	–	12	12.5	–	V
		± 10	± 13	–	10	12	–	
		± 10	–	–	10	–	–	
Input Common Mode Voltage Range	V_{ICR}	+13 V – V_{EE}	+13 V – V_{EE}	–	+12 V – V_{EE}	+12.5 V – V_{EE}	–	V
Common Mode Rejection $R_S \leq 10\text{ k}\Omega$	CMR	70	90	–	70	90	–	dB
Power Supply Current ($V_O = 0$) $R_L = \infty$	I_{CC} , I_{EE}	–	2.8	7.0	–	2.8	7.0	mA
Individual Output Short-Circuit Current (Note 2)	I_{SC}	± 10	± 20	± 45	± 10	± 30	± 45	mA
Positive Power Supply Rejection Ratio	PSRR+	–	30	150	–	30	150	$\mu\text{V/V}$
Negative Power Supply Rejection Ratio	PSRR–	–	30	150	–	30	150	$\mu\text{V/V}$
Average Temperature Coefficient of Input Offset Current $T_A = T_{\text{high}}$ to T_{low}	$\Delta I_{IO}/\Delta T$	–	50	–	–	50	–	$\text{pA}/^\circ\text{C}$
Average Temperature Coefficient of Input Offset Voltage $T_A = T_{\text{high}}$ to T_{low}	$\Delta V_{IO}/\Delta T$	–	10	–	–	10	–	$\mu\text{V}/^\circ\text{C}$
Power Bandwidth $A_V = 1$, $R_L = 10\text{ k}\Omega$, $V_O = 20\text{ V(p-p)}$, THD = 5%	BWp	–	9.0	–	–	9.0	–	kHz
Small-Signal Bandwidth $A_V = 1$, $R_L = 10\text{ k}\Omega$, $V_O = 50\text{ mV}$	BW	–	1.0	–	–	1.0	–	MHz
Slew Rate $A_V = 1$, $V_i = -10\text{ V}$ to $+10\text{ V}$	SR	–	0.6	–	–	0.6	–	V/ μs
Rise Time $A_V = 1$, $R_L = 10\text{ k}\Omega$, $V_O = 50\text{ mV}$	t_{TLH}	–	0.35	–	–	0.35	–	μs
Fall Time $A_V = 1$, $R_L = 10\text{ k}\Omega$, $V_O = 50\text{ mV}$	t_{TLH}	–	0.35	–	–	0.35	–	μs
Overshoot $A_V = 1$, $R_L = 10\text{ k}\Omega$, $V_O = 50\text{ mV}$	os	–	20	–	–	20	–	%
Phase Margin $A_V = 1$, $R_L = 2.0\text{ k}\Omega$, $V_O = 200\text{ pF}$	ϕ_m	–	60	–	–	60	–	Degrees
Crossover Distortion ($V_{in} = 30\text{ mVpp}$, $V_{out} = 2.0\text{ Vpp}$, $f = 10\text{ kHz}$)	–	–	1.0	–	–	1.0	–	%

NOTES: 1. $T_{\text{high}} = +70^\circ\text{C}$ for MC3403, $+85^\circ\text{C}$ for MC3303
 $T_{\text{low}} = 0^\circ\text{C}$ for MC3403, -40°C for MC3303
 2. Not to exceed maximum package power dissipation.

勝特力材料 86-3-5753170
 勝特力电子(上海) 86-21-54151736
 勝特力电子(深圳) 86-755-83298787
[Http://www.100y.com.tw](http://www.100y.com.tw)

MC3403 MC3303

ELECTRICAL CHARACTERISTICS ($V_{CC} = 5.0\text{ V}$, $V_{EE} = \text{Gnd}$, $T_A = 25^\circ\text{C}$, unless otherwise noted.)

Characteristic	Symbol	MC3403			MC3303			Unit
		Min	Typ	Max	Min	Typ	Max	
Input Offset Voltage	V_{IO}	-	2.0	10	-	-	10	mV
Input Offset Current	I_{IO}	-	30	50	-	-	75	nA
Input Bias Current	I_{IB}	-	-200	-500	-	-	-500	nA
Large Signal Open Loop Voltage Gain $R_L = 2.0\text{ k}\Omega$	A_{VOL}	10	200	-	10	200	-	V/mV
Power Supply Rejection Ratio	PSRR	-	-	150	-	-	150	$\mu\text{V/V}$
Output Voltage Range (Note 3) $R_L = 10\text{ k}\Omega$, $V_{CC} = 5.0\text{ V}$ $R_L = 10\text{ k}\Omega$, $5.0 \leq V_{CC} \leq 30\text{ V}$	VOR	3.3 $V_{CC}-2.0$	3.5 $V_{CC}-1.7$	- -	3.3 $V_{CC}-2.0$	3.5 $V_{CC}-1.7$	- -	Vpp
Power Supply Current	I_{CC}	-	2.5	7.0	-	2.5	7.0	mA
Channel Separation $f = 1.0\text{ kHz to }20\text{ kHz}$ (Input Referenced)	CS	-	-120	-	-	-120	-	dB

NOTES: 3. Output will swing to ground with a 10 k Ω pull down resistor.

勝特力材料 886-3-5753170
 勝特力电子(上海) 86-21-54151736
 勝特力电子(深圳) 86-755-83298787
[Http://www.100y.com.tw](http://www.100y.com.tw)

Representative Schematic Diagram
(1/4 of Circuit Shown)

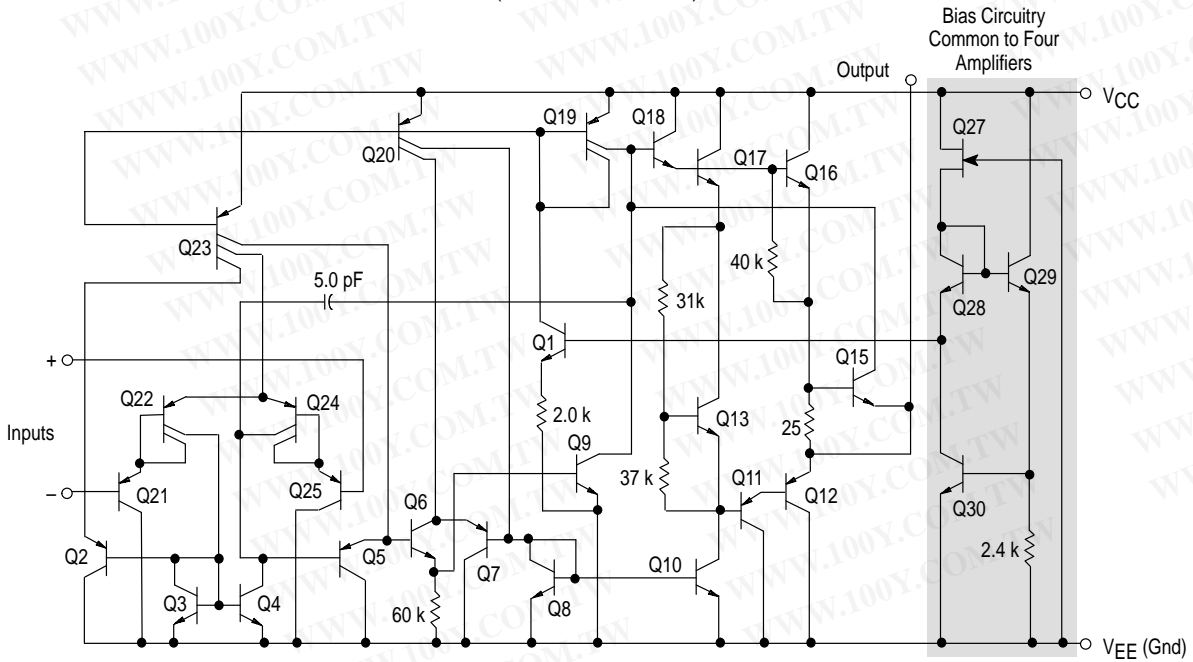

MC3403 MC3303

CIRCUIT DESCRIPTION

勝特力材料 886-3-5753170
勝特力电子(上海) 86-21-54151736
勝特力电子(深圳) 86-755-83298787
[Http://www.100y.com.tw](http://www.100y.com.tw)

Inverter Pulse Response

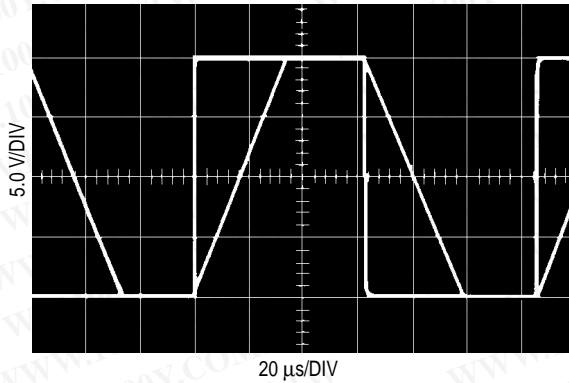

The MC3403/3303 is made using four internally compensated, two-stage operational amplifiers. The first stage of each consists of differential input device Q24 and Q22 with input buffer transistors Q25 and Q21 and the differential to single ended converter Q3 and Q4. The first

stage performs not only the first stage gain function but also performs the level shifting and transconductance reduction functions. By reducing the transconductance, a smaller compensation capacitor (only 5.0 pF) can be employed, thus saving chip area. The transconductance reduction is accomplished by splitting the collectors of Q24 and Q22. Another feature of this input stage is that the input common mode range can include the negative supply or ground, in single supply operation, without saturating either the input devices or the differential to single-ended converter. The second stage consists of a standard current source load amplifier stage.

The output stage is unique because it allows the output to swing to ground in single supply operation and yet does not exhibit any crossover distortion in split supply operation. This is possible because Class AB operation is utilized.

Each amplifier is biased from an internal voltage regulator which has a low temperature coefficient, thus giving each amplifier good temperature characteristics as well as excellent power supply rejection.

Figure 1. Sine Wave Response

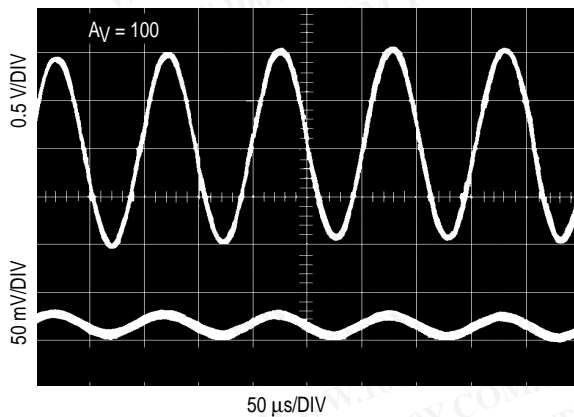
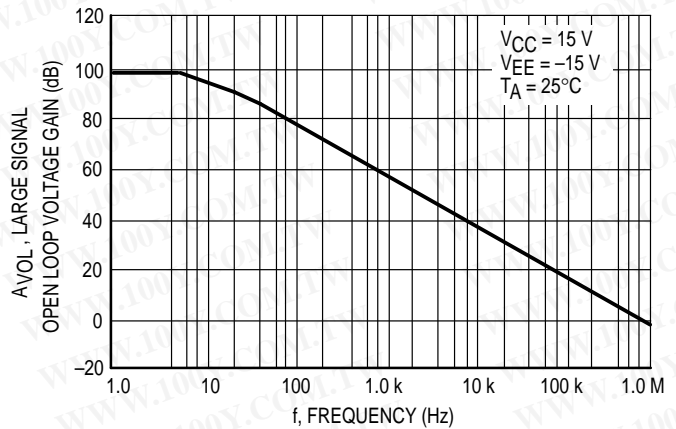

Figure 2. Open Loop Frequency Response



MC3403 MC3303

Figure 3. Power Bandwidth

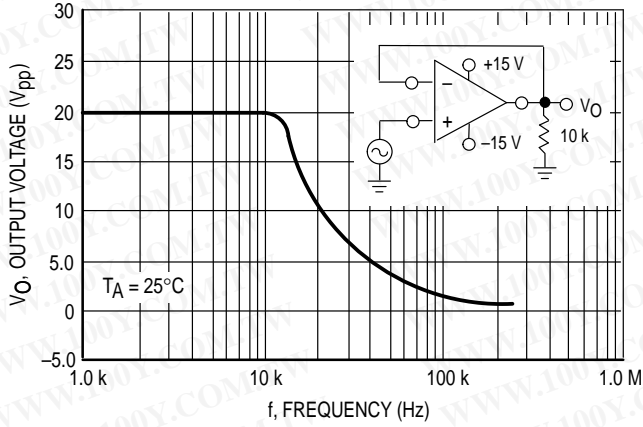

Figure 4. Output Swing versus Supply Voltage

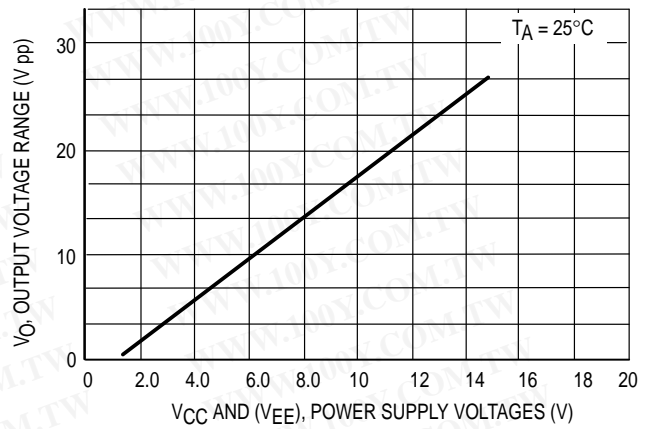

Figure 5. Input Bias Current versus Temperature

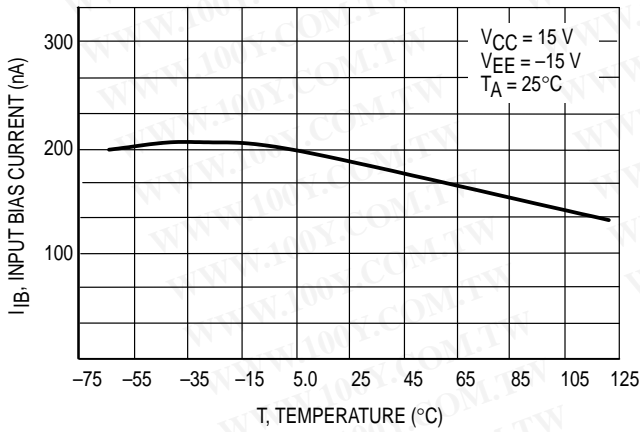

Figure 6. Input Bias Current versus Supply Voltage

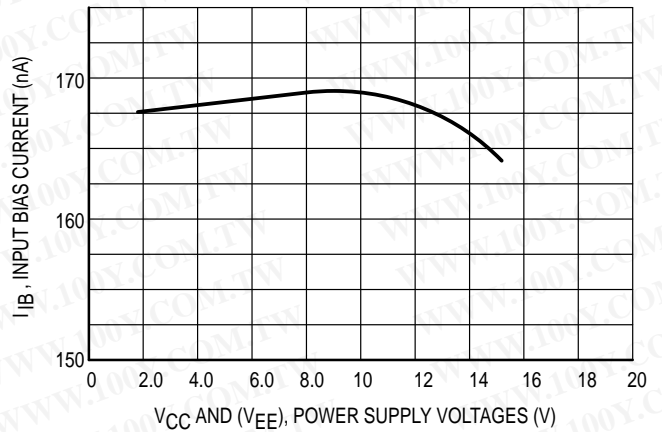

Figure 7. Voltage Reference

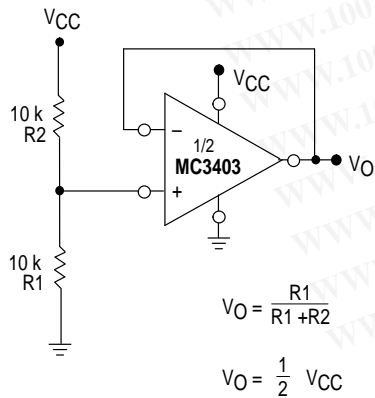
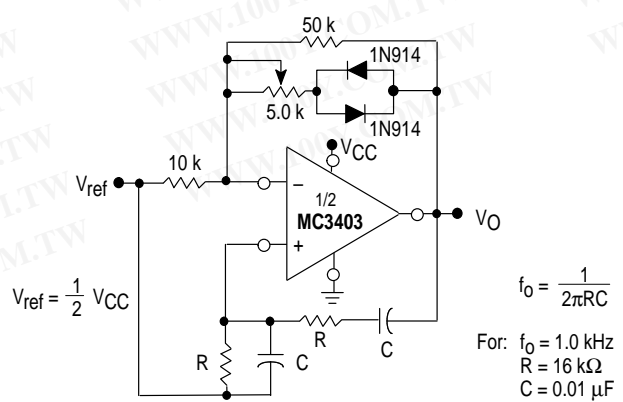

Figure 8. Wien Bridge Oscillator



勝特力材料 886-3-5753170
 勝特力电子(上海) 86-21-54151736
 勝特力电子(深圳) 86-755-83298787

[Http://www.100y.com.tw](http://www.100y.com.tw)

MC3403 MC3303

Figure 9. High Impedance Differential Amplifier

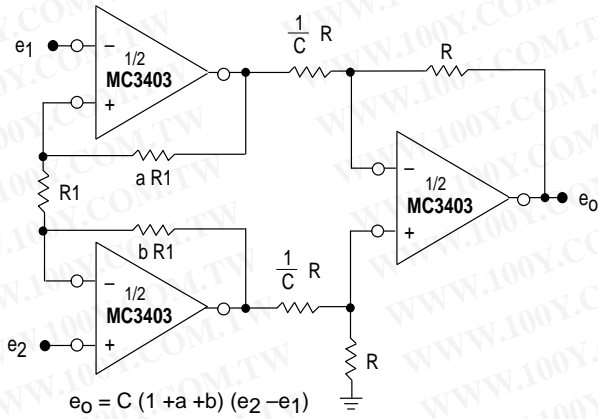

Figure 10. Comparator with Hysteresis

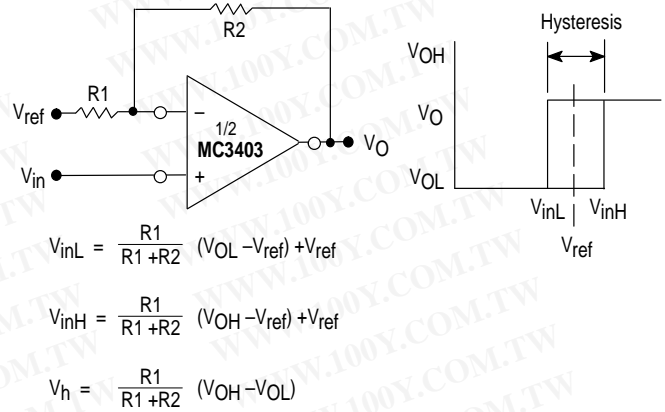

Figure 11. Bi-Quad Filter

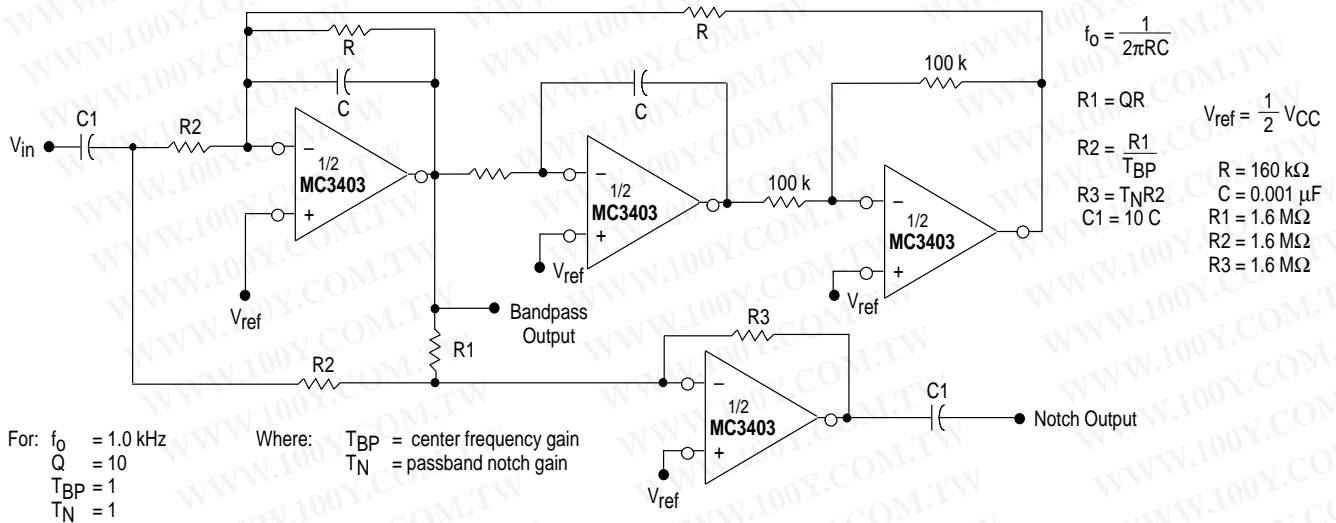

Figure 12. Function Generator

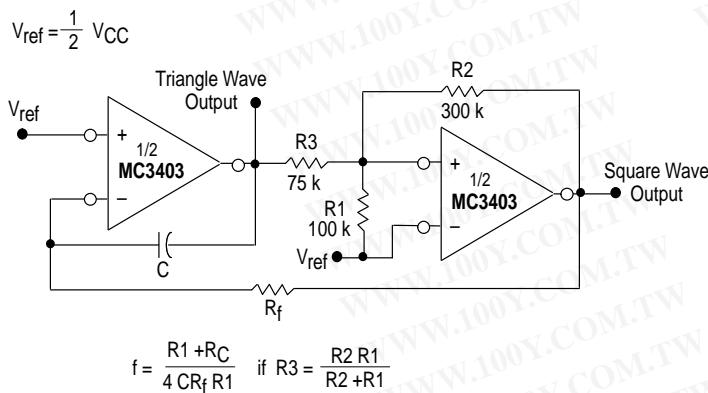
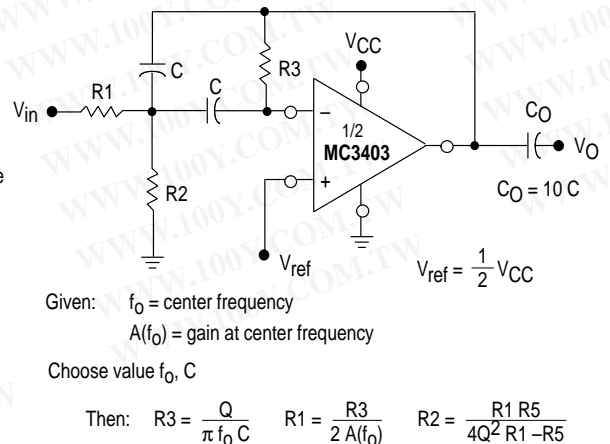

Figure 13. Multiple Feedback Bandpass Filter



For less than 10% error from operational amplifier where f_o and BW are expressed in Hz. $\frac{Q_o f_o}{BW} < 0.1$

If source impedance varies, filter may be preceded with voltage follower buffer to stabilize filter parameters.

勝特力材料 886-3-5753170
勝特力电子(上海) 86-21-54151736
勝特力电子(深圳) 86-755-83298787
[Http://www.100y.com.tw](http://www.100y.com.tw)

MC3403 MC3303

OUTLINE DIMENSIONS

勝特力材料 886-3-5753170
勝特力电子(上海) 86-21-54151736
勝特力电子(深圳) 86-755-83298787
[Http://www.100y.com.tw](http://www.100y.com.tw)

D SUFFIX
 PLASTIC PACKAGE
 CASE 751A-03
 ISSUE F
 (SO-14)

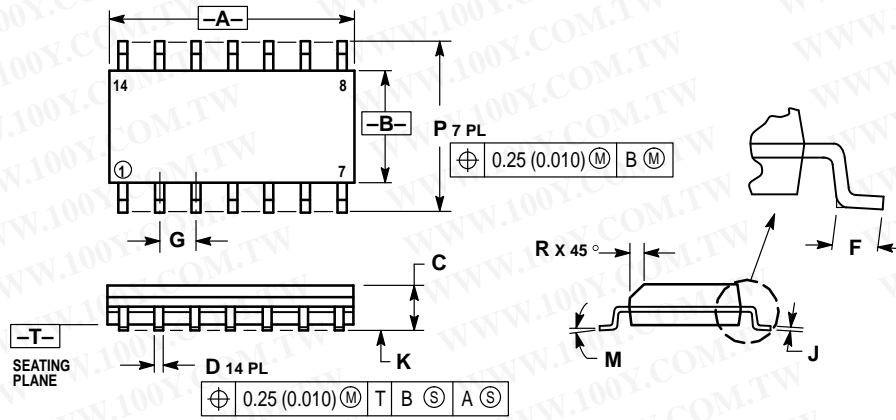

- NOTES:
- DIMENSIONING AND TOLERANCING PER ANSI Y14.5M, 1982.
 - CONTROLLING DIMENSION: MILLIMETER.
 - DIMENSIONS A AND B DO NOT INCLUDE MOLD PROTRUSION.
 - MAXIMUM MOLD PROTRUSION 0.15 (0.006) PER SIDE.
 - DIMENSION D DOES NOT INCLUDE DAMBAR PROTRUSION. ALLOWABLE DAMBAR PROTRUSION SHALL BE 0.127 (0.005) TOTAL IN EXCESS OF THE D DIMENSION AT MAXIMUM MATERIAL CONDITION.

DIM	MILLIMETERS		INCHES	
	MIN	MAX	MIN	MAX
A	8.55	8.75	0.337	0.344
B	3.80	4.00	0.150	0.157
C	1.35	1.75	0.054	0.068
D	0.35	0.49	0.014	0.019
F	0.40	1.25	0.016	0.049
G	1.27 BSC		0.050 BSC	
J	0.19	0.25	0.008	0.009
K	0.10	0.25	0.004	0.009
M	0°	7°	0°	7°
P	5.80	6.20	0.228	0.244
R	0.25	0.50	0.010	0.019

P SUFFIX
 PLASTIC PACKAGE
 CASE 646-06
 ISSUE L

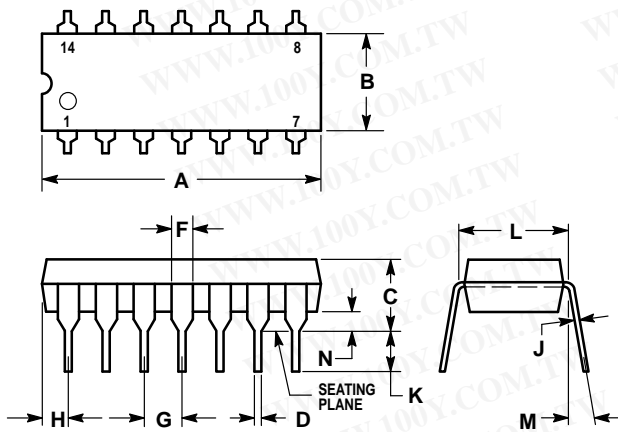

- NOTES:
- LEADS WITHIN 0.13 (0.005) RADIUS OF TRUE POSITION AT SEATING PLANE AT MAXIMUM MATERIAL CONDITION.
 - DIMENSION L TO CENTER OF LEADS WHEN FORMED PARALLEL.
 - DIMENSION B DOES NOT INCLUDE MOLD FLASH.
 - ROUNDED CORNERS OPTIONAL.

DIM	INCHES		MILLIMETERS	
	MIN	MAX	MIN	MAX
A	0.715	0.770	18.16	19.56
B	0.240	0.260	6.10	6.60
C	0.145	0.185	3.69	4.69
D	0.015	0.021	0.38	0.53
F	0.040	0.070	1.02	1.78
G	0.100 BSC		2.54 BSC	
H	0.052	0.095	1.32	2.41
J	0.008	0.015	0.20	0.38
K	0.115	0.135	2.92	3.43
L	0.300 BSC		7.62 BSC	
M	0°	10°	0°	10°
N	0.015	0.039	0.39	1.01