

MOC8204

DESCRIPTION

The MOC8204 device consists of a gallium arsenide infrared emitting diode optically coupled to a high voltage, silicon, phototransistor detector in a standard 6-pin DIP package. It is designed for high voltage applications and is particularly useful in copy machines and solid state relays.

APPLICATIONS

- Copy Machines
- Interfacing and coupling systems of different potentials and impedances
- Monitor and Detection Circuits
- Solid State Relays

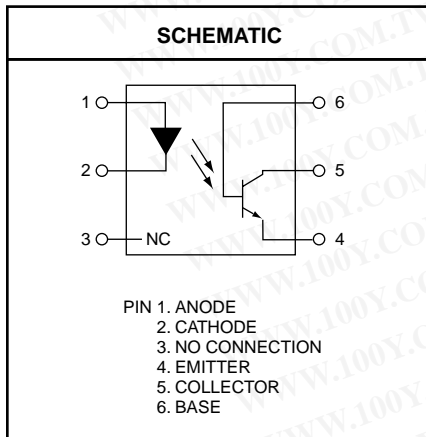
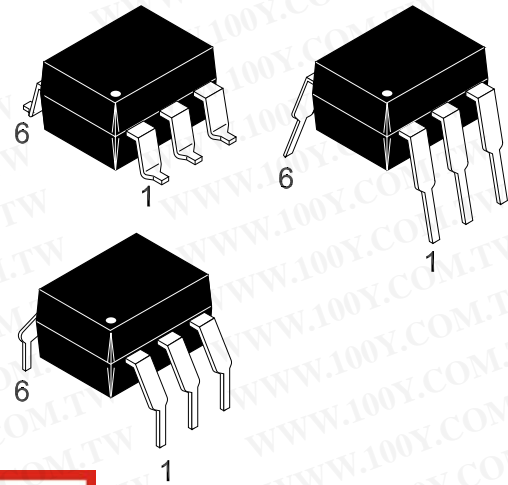

勝特力材料 886-3-5753170
 勝特力电子(上海) 86-21-54151736
 勝特力电子(深圳) 86-755-83298787
[Http://www.100y.com.tw](http://www.100y.com.tw)

Parameter	Symbol	Value	Units
TOTAL DEVICE			
Storage Temperature	T_{STG}	-55 to +150	°C
Operating Temperature	T_{OPR}	-55 to +100	°C
Lead Solder Temperature	T_{SOL}	260 for 10 sec	°C
Input-Output Isolation Voltage Peak ac Voltage, 60 Hz, 1 Second Duration ⁽¹⁾	V_{ISO}	7500	Vac(pk)
Total Device Power Dissipation @ $T_A = 25^\circ\text{C}$ Derate above 25°C	P_D	250 2.94	mW
EMITTER			
DC/Average Forward Input Current	I_F	60	mA
Forward Current - Peak (Pulse Width = 1µs, 330 pps)	$I_F(pk)$	1.2	A
LED Power Dissipation @ $T_A = 25^\circ\text{C}$ Derate above 25°C	P_D	120 1.41	mW mW/°C
DETECTOR			
Collector-Emitter Voltage	V_{CEO}	400	V
Collector-Base Voltage	V_{CBO}	400	V
Emitter-Collector Voltage	V_{ECO}	7	V
Detector Power Dissipation @ $T_A = 25^\circ\text{C}$ Derate above 25°C	P_D	150 1.76	mW mW/°C

勝特力材料 886-3-5753170
勝特力电子(上海) 86-21-54151736
勝特力电子(深圳) 86-755-83298787
[Http://www.100y.com.tw](http://www.100y.com.tw)

MOC8204

ELECTRICAL CHARACTERISTICS ($T_A = 25^\circ\text{C}$ Unless otherwise specified.)

INDIVIDUAL COMPONENT CHARACTERISTICS

Parameter	Test Conditions	Symbol	Min	Typ ⁽¹⁾	Max	Unit
EMITTER						
Input Forward Voltage	($I_F = 10\text{ mA}$)	V_F	—	1.2	15	V
Reverse Leakage Current	($V_R = 6.0\text{ V}$)	I_R	—	—	10	μA
Capacitance	($V = 0, f = 1\text{ MHz}$)	C_J	—	18	—	pF
DETECTOR						
Collector-Emitter Breakdown Voltage ($I_C = 1.0\text{ mA}, R_{BE} = 1\text{ M}\Omega$)		BV_{CEO}	400	—	—	V
Collector-Base Breakdown Voltage ($I_C = 100\text{ }\mu\text{A}$)		BV_{CBO}	400	—	—	V
Emitter-Base Breakdown Voltage ($I_E = 100\text{ }\mu\text{A}$)		BV_{EBO}	7	—	—	V
Collector-Emitter Dark Current		I_{CEO}	—	—	100	nA
$T_A = 25^\circ\text{C}$	($R_{BE} = 1\text{ M}\Omega, V_{CE} = 300\text{ V}$)				250	μA
$T_A = 100^\circ\text{C}$						

ISOLATION CHARACTERISTICS

Characteristic	Test Conditions	Symbol	Min	Typ ⁽¹⁾	Max	Units
Output Collector Current	($V_{CE} = 10\text{ V}, I_F = 10\text{ mA}, R_{BE} = 1\text{ M}\Omega$)	I_C (CTR) ⁽²⁾	2 (20)	—	—	mA(%)
Collector-Emitter Saturation Voltage ($I_C = 0.5\text{ mA}, I_F = 10\text{ mA}, R_{BE} = 1\text{ M}\Omega$)		$V_{(SAT)}$	—	—	0.4	V
Input-Output Isolation Voltage ⁽³⁾	($I_{I-O} \leq 1\text{ }\mu\text{A}, \text{Time} = 1\text{ min}$)	V_{ISO}	5300	—	—	$V_{AC(RMS)}$
			7300	—	—	$V_{AC(PEAK)}$
Isolation Resistance ⁽³⁾		R_{ISO}	—	10^{11}	—	Ω
Isolation Capacitance ⁽¹⁾		C_{ISO}	—	0.2	—	pf
Turn-On Time	($V_{CC} = 10\text{ V}, I_C = 2\text{ mA}, R_L = 100\Omega$)	t_{ON}	—	5	—	μs
Turn-Off Time		t_{OFF}	—	5	—	

Notes

1. Always design to the specified minimum/maximum electrical limits (where applicable).
2. Current Transfer Ratio (CTR) = $I_C / I_F \times 100\%$.
3. For this test LED pins 1 and 2 are common and phototransistor Pins 4,5 and 6 are common.

勝特力材料 886-3-5753170
 勝特力电子(上海) 86-21-54151736
 勝特力电子(深圳) 86-755-83298787
[Http://www.100y.com.tw](http://www.100y.com.tw)

MOC8204

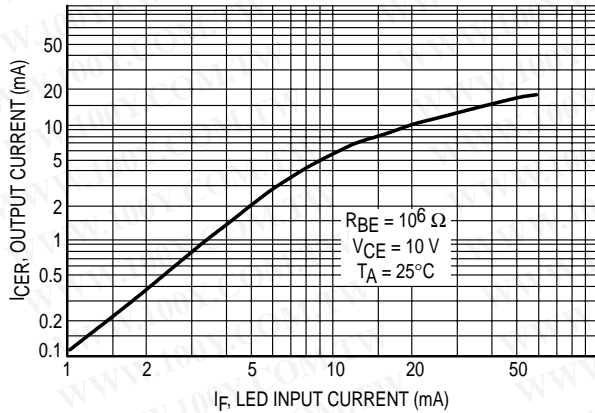

Figure 1. Output Current versus LED Input Current

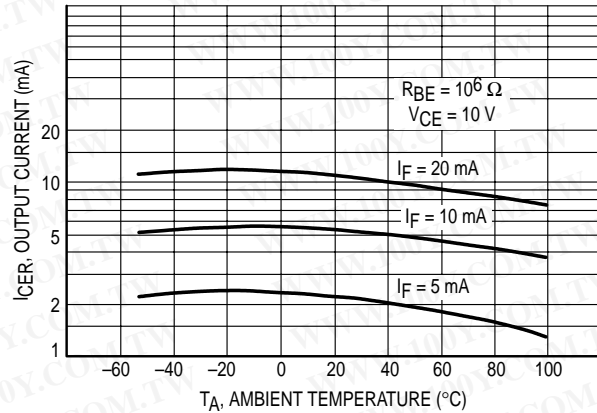

Figure 2. Output Current versus Temperature

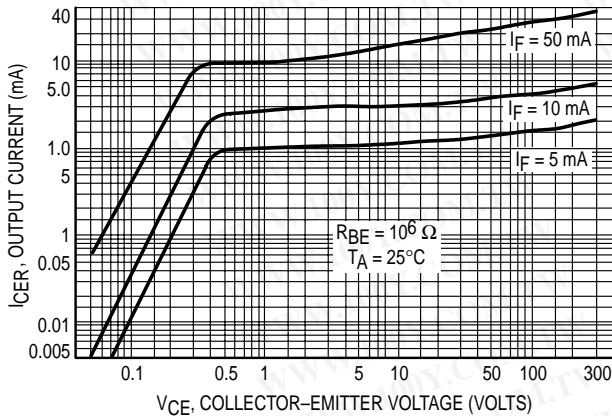

Figure 3. Output Characteristics

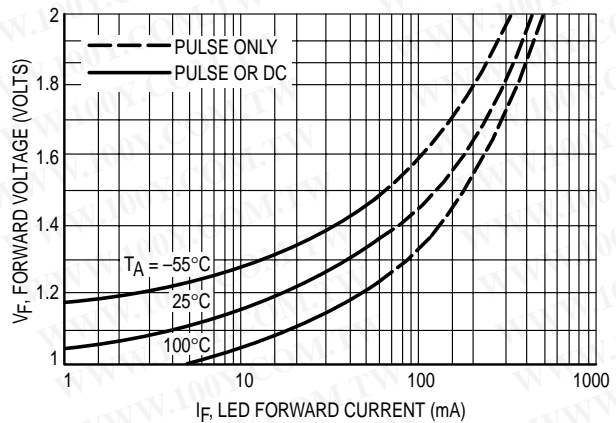

Figure 4. Forward Characteristics

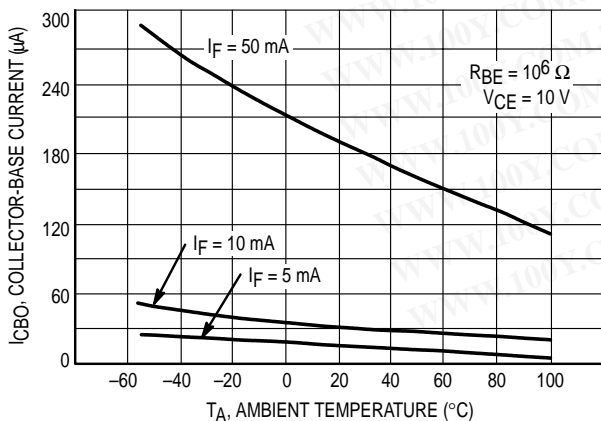

Figure 5. Collector-Base Current versus Temperature

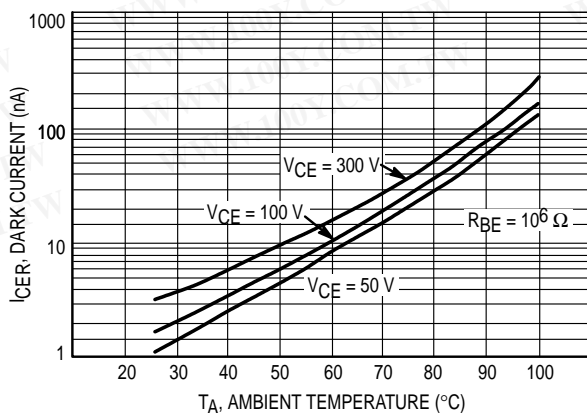
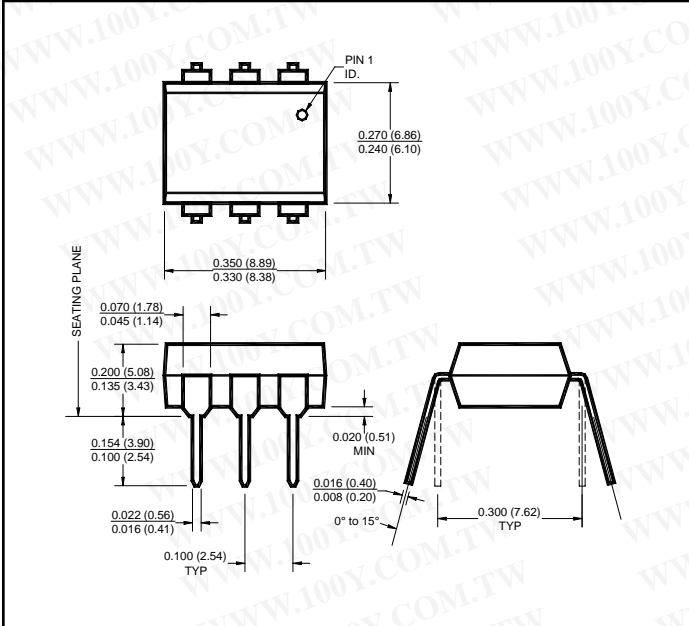

Figure 6. Dark Current versus Temperature

MOC8204

Package Dimensions (Through Hole)



Package Dimensions (Surface Mount)

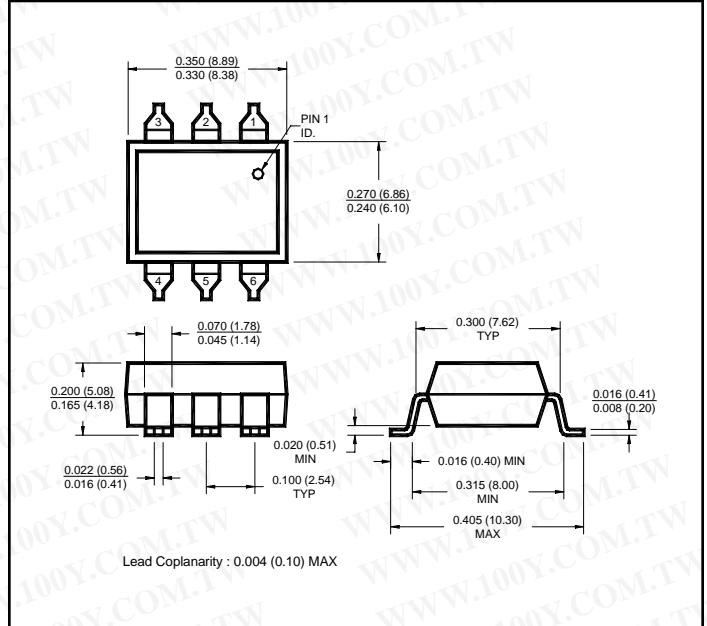

Package Dimensions (0.4" Lead Spacing)

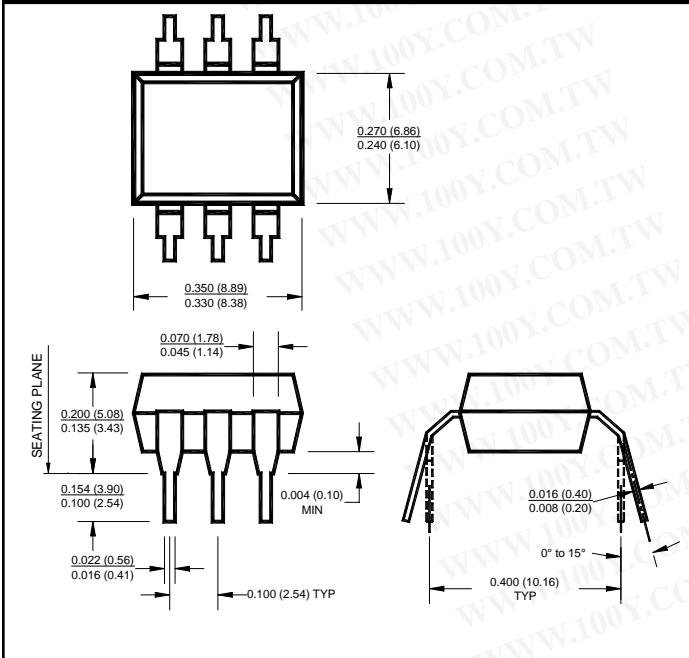

**Recommended Pad Layout for
Surface Mount Leadform**

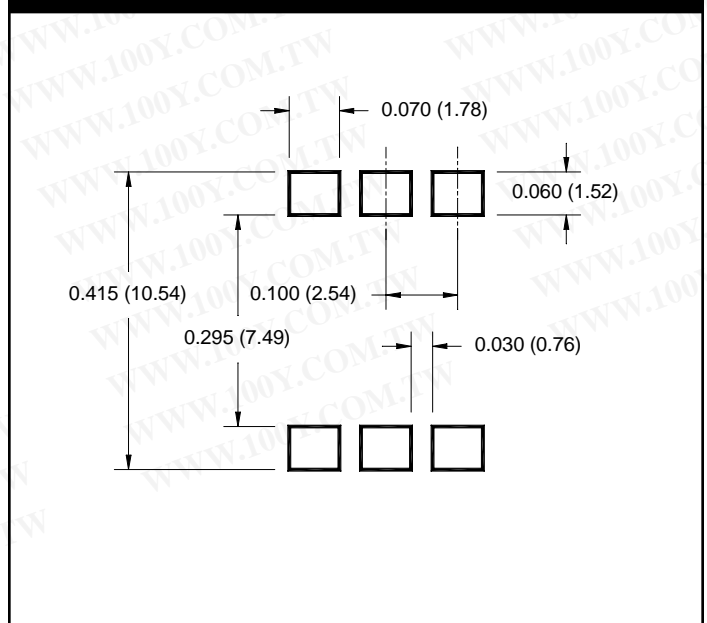

勝特力材料 886-3-5753170
勝特力电子(上海) 86-21-54151736
勝特力电子(深圳) 86-755-83298787
[Http://www.100y.com.tw](http://www.100y.com.tw)

勝特力材料 886-3-5753170
 勝特力电子(上海) 86-21-54151736
 勝特力电子(深圳) 86-755-83298787
[Http://www.100y.com.tw](http://www.100y.com.tw)

MOC8204

ORDERING INFORMATION

Option	Order Entry Identifier	Description
R2	.R2	Opto Plus Reliability Conditioning
S	.S	Surface Mount Lead Bend
SD	.SD	Surface Mount; Tape and reel
SDL	.SDL	Surface Mount; Tape and reel
W	.W	0.4" Lead Spacing
300	.300	VDE 0884
300W	.300W	VDE 0884, 0.4" Lead Spacing
3S	.3S	VDE 0884, Surface Mount
3SD	.3SD	VDE 0884, Surface Mount, Tape & Reel

QT Carrier Tape Specifications

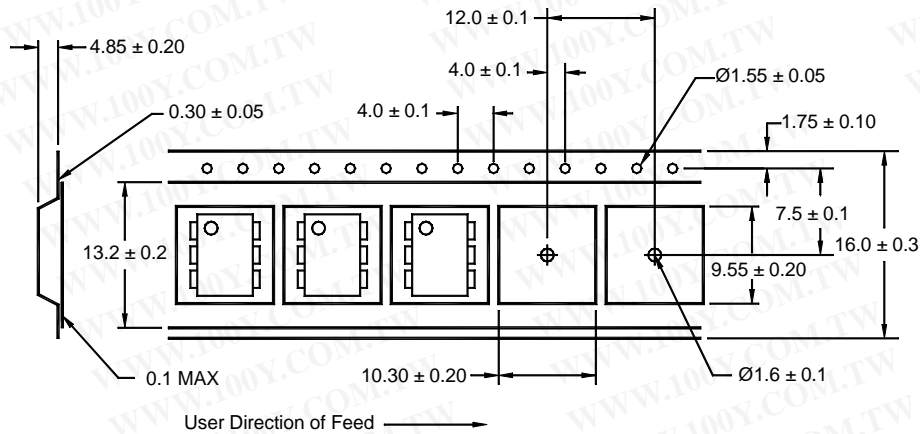

DISCLAIMER

FAIRCHILD SEMICONDUCTOR RESERVES THE THE RIGHT TO MAKE CHANGES WITHOUT FURTHER NOTICE TO ANY PRODUCTS HEREIN TO IMPROVE RELIABILITY, FUNCTION OR DESIGN. FAIRCHILD DOES NOT ASSUME ANY LIABILITY ARISING OUT OF THE APPLICATION OR USE OF ANY PRODUCT OR CIRCUIT DESCRIBED HEREIN; NEITHER DOES IT CONVEY ANY LICENSE UNDER ITS PATENT RIGHTS, NOR THE RIGHTS OF OTHERS.

LIFE SUPPORT POLICY

FAIRCHILD'S PRODUCTS ARE NOT AUTHORIZED FOR USE AS CRITICAL COMPONENTS IN LIFE SUPPORT DEVICES OR SYSTEMS WITHOUT THE EXPRESS WRITTEN APPROVAL OF THE PRESIDENT OF FAIRCHILD SEMICONDUCTOR CORPORATION. As used herein:

1. Life support devices or systems are devices or systems which, (a) are intended for surgical implant into the body, or (b) support or sustain life, and (c) whose failure to perform when properly used in accordance with instructions for use provided in labeling, can be reasonably expected to result in a significant injury of the user.
2. A critical component in any component of a life support device or system whose failure to perform can be reasonably expected to cause the failure of the life support device or system, or to affect its safety or effectiveness.

勝特力材料 886-3-5753170
勝特力电子(上海) 86-21-54151736
勝特力电子(深圳) 86-755-83298787
[Http://www.100y.com.tw](http://www.100y.com.tw)