

MOTOROLA
SEMICONDUCTOR
TECHNICAL DATA

MC3447

**BIDIRECTIONAL INSTRUMENTATION
 BUS (GPIB) TRANSCEIVER**

This bidirectional bus transceiver is intended as the interface between TTL or MOS logic and the IEEE Standard Instrumentation Bus (488-1978, often referred to as GPIB). The required bus termination is internally provided.

Low power consumption has been achieved by trading a minimum of speed for low current drain on non-critical channels. A fast channel is provided for critical ATN and EOI paths.

Each driver/receiver pair forms the complete interface between the bus and an instrument. Either the driver or the receiver of each channel is enabled by a Send/Receive input with the disabled output of the pair forced to a high impedance state. The receivers have input hysteresis to improve noise margin, and their input loading follows the bus standard specifications.

- Low Power —
 Average Power Supply Current = 30 mA Listening
 75 mA Talking
- Eight Driver/Receiver Pairs
- Three-State Outputs
- High Impedance Inputs
- Receiver Hysteresis — 600 mV (Typ)
- Fast Propagation Times — 15–20 ns (Typ)
- TTL Compatible Receiver Outputs
- Single +5 Volt Supply
- Open Collector Driver Output with Terminations
- Power Up/Power Down Protection
 (No Invalid Information Transmitted to Bus)
- No Bus Loading When Power is Removed From Device
- Terminations Provided: Termination Removed When Device is Unpowered

**OCTAL BIDIRECTIONAL
 BUS TRANSCEIVER
 WITH
 TERMINATION NETWORKS**
**SILICON MONOLITHIC
 INTEGRATED CIRCUIT**

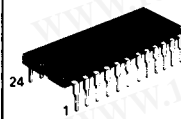

L SUFFIX
 CERAMIC PACKAGE
 CASE 623

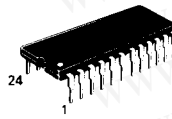

P SUFFIX
 PLASTIC PACKAGE
 CASE 649



P3 SUFFIX
 PLASTIC PACKAGE
 CASE 724

7

PIN CONNECTIONS

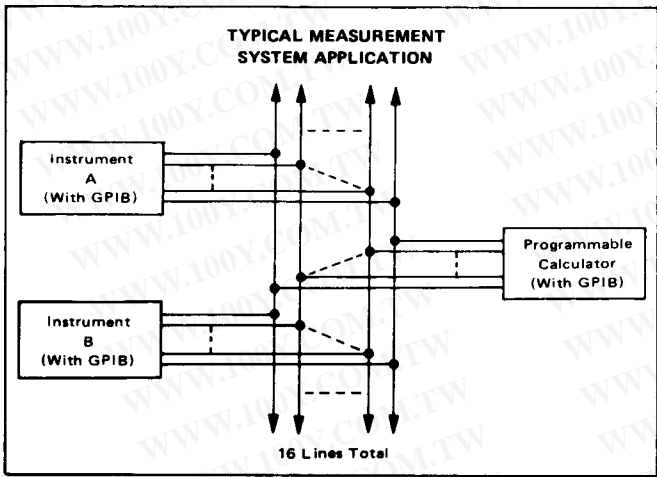
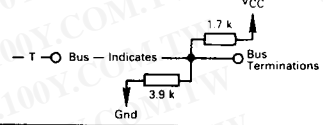
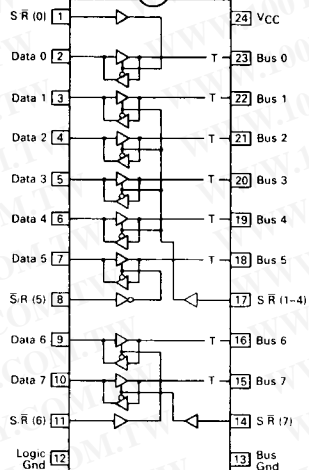

MC3447

勝特力材料 886-3-5753170
 勝特力电子(上海) 86-21-54151736
 勝特力电子(深圳) 86-755-83298787
[Http://www.100y.com.tw](http://www.100y.com.tw)

MAXIMUM RATINGS (T_A = 25°C unless otherwise noted)

Rating	Symbol	Value	Unit
Power Supply Voltage	V _{CC}	7.0	Vdc
Input Voltage	V _I	5.5	Vdc
Driver Output Current	I _{O(D)}	150	mA
Junction Temperature	T _J	150	°C
Operating Ambient Temperature Range	T _A	0 to +70	°C
Storage Temperature Range	T _{stg}	-65 to +150	°C

ELECTRICAL CHARACTERISTICS

(Unless otherwise noted 4.50 V ≤ V_{CC} ≤ 5.50 V and 0 ≤ T_A ≤ 70°C; typical values are at T_A = 25°C, V_{CC} = 5.0 V)

Characteristic — Note 1	Symbol	Min	Typ	Max	Unit	
Bus Voltage (Bus Pin Open) (V _{I(S/R)} = 0.8 V) (I _(Bus) = -12 mA)	V _(Bus) V _{IC(Bus)}	2.5 -	- -	3.7 -1.5	V	
Bus Current (5.0 V ≤ V _(Bus) ≤ 5.5 V) (V _(Bus) = 0.5 V) (V _{CC} = 0 V, 0 V ≤ V _(Bus) ≤ 2.75 V)	I _(Bus)	0.7 -1.3 -	- - -	2.5 -3.2 +0.04	mA	
Receiver Input Hysteresis (V _{I(S/R)} = 0.8 V)	-	400	600	-	mV	
Receiver Input Threshold (V _{I(S/R)} = 0.8 V)	Low to High High to Low	V _{ILH(R)} V _{IHL(R)}	- 0.8	1.6 1.0	2.0 -	V
Receiver Output Voltage — High Logic State (V _{I(S/R)} = 0.8 V, I _{OH(R)} = -200 μA, V _(Bus) = 2.0 V)	V _{OH(R)}	2.4	-	-	V	
Receiver Output Voltage — Low Logic State (V _{I(S/R)} = 0.8 V, I _{OL(R)} = 4.0 mA, V _(Bus) = 0.8 V)	V _{OL(R)}	-	-	0.5	V	
Receiver Output Short Circuit Current (V _{I(S/R)} = 0.8 V, V _(Bus) = 2.0 V)	I _{OS(R)}	-4.0	-	-20	mA	
Driver Input Voltage — High Logic State (V _{I(S/R)} = 2.0 V)	V _{IH(D)}	2.0	-	-	V	
Driver Input Voltage — Low Logic State (V _{I(S/R)} = 2.0 V)	V _{IL(D)}	-	-	0.8	V	
Driver Input Current — Data Pins (V _{I(S/R)} = 2.0 V) (0.5 ≤ V _{I(D)} ≤ 2.7 V) (V _{I(D)} = 5.5 V)	I _{I(D)} I _{IB(D)}	-100 -	- -	40 200	μA	
Input Current — Send/Receive (0.5 ≤ V _{I(S/R)} < 2.7 V) (V _{I(S/R)} = 5.5 V)	I _{I(S/R)} I _{IB(S/R)}	-250 -	- -	20 100	μA	
Driver Input Clamp Voltage (V _{I(S/R)} = 2.0 V, I _{IC(D)} = -18 mA)	V _{IC(D)}	-	-	-1.5	V	
Driver Output Voltage — High Logic State (V _{I(S/R)} = 2.0 V, V _{IH(D)} = 2.0 V)	V _{OH(D)}	2.5	-	-	V	
Driver Output Voltage — Low Logic State (Note 2) (V _{I(S/R)} = 2.0 V, V _{IL(D)} = 0.8 V, I _{OL(D)} = 48 mA)	V _{OL(D)}	-	-	0.5	V	
Power Supply Current (Listening Mode — All Receivers On) (Talking Mode — All Drivers On)	I _{CCL} I _{CCH}	- -	30 75	45 95	mA	

SWITCHING CHARACTERISTICS (V_{CC} = 5.0 V, T_A = 25°C unless otherwise noted)

Propagation Delay of Driver (Output Low to High) (Output High to Low)	t _{PLH(D)} t _{PHL(D)}	- -	7.0 16	15 30	ns
Propagation Delay of Receiver (Channels 0 to 5, 7) (Output Low to High) (Output High to Low)	t _{PLH(R)} t _{PHL(R)}	- -	28 15	50 30	ns
Propagation Delay of Receiver (Channel 6, Note 3) (Output Low to High) (Output High to Low)	t _{PLH(R)} t _{PHL(R)}	- -	17 12	30 22	ns

- NOTES: 1. Specified test conditions for V_{I(S/R)} are 0.8 V (Low) and 2.0 V (High). Where V_{I(S/R)} is specified as a test condition, V_{I(S/R)} uses the opposite logic levels.
 2. The IEEE 488-1979 Bus Standard changes V_{OL(D)} from 0.4 to 0.5 V maximum to permit the use of Schottky technology.
 3. In order to meet the IEEE 488-1978 Standard for total system delay on the ATN and EOI channels, a fast receiver has been provided on Channel 6 (Pins 9 and 16).

MC3447

勝特力材料 886-3-5753170
 勝特力电子(上海) 86-21-54151736
 勝特力电子(深圳) 86-755-83298787
[Http://www.100y.com.tw](http://www.100y.com.tw)

SWITCHING CHARACTERISTICS (continued) ($V_{CC} = 5.0\text{ V}$, $T_A = 25^\circ\text{C}$ unless otherwise noted)

Characteristic	Symbol	Min	Typ	Max	Unit
Propagation Delay Time – Send/Receiver to Data					
Logic High to Third State	$t_{PHZ}(R)$	–	15	30	ns
Third State to Logic High	$t_{PZH}(R)$	–	15	30	
Logic Low to Third State	$t_{PLZ}(R)$	–	15	25	
Third State to Logic Low	$t_{PZL}(R)$	–	10	25	
Propagation Delay Time – Send/Receiver to Bus					
Logic Low to Third State	$t_{PLZ}(D)$	–	13	25	ns
Third State to Logic Low	$t_{PZL}(D)$	–	30	50	

PROPAGATION DELAY TEST CIRCUITS AND WAVEFORMS

FIGURE 1 – BUS INPUT TO DATA OUTPUT (RECEIVER)

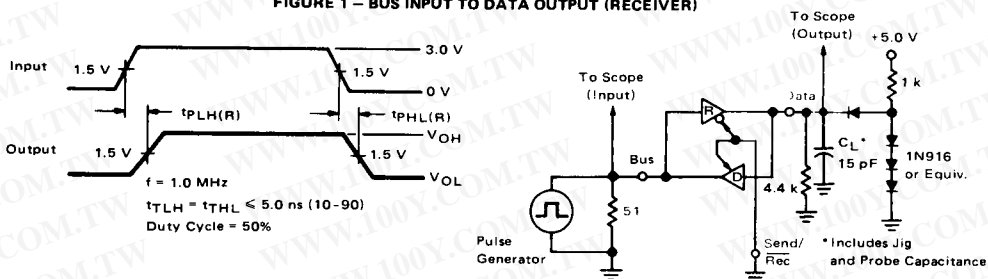

FIGURE 2 – DATA INPUT TO BUS OUTPUT (DRIVER)

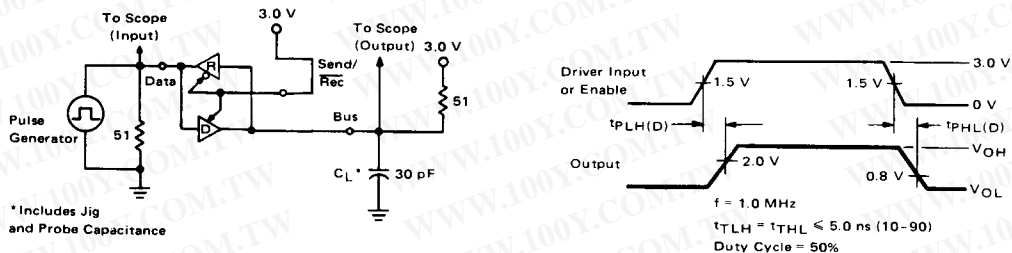
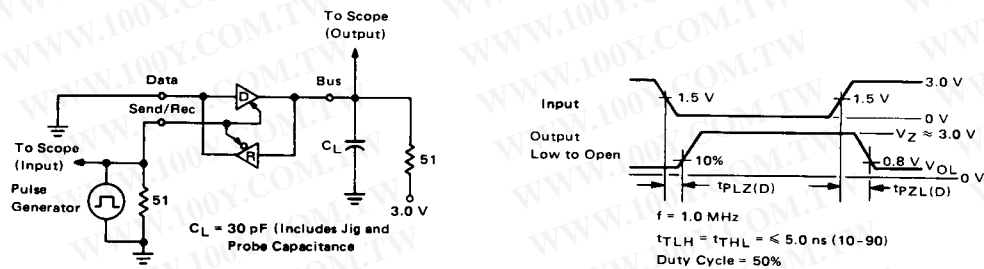

FIGURE 3 – SEND/RECEIVE INPUT TO BUS OUTPUT (DRIVER)



MC3447

FIGURE 4 - SEND/RECEIVE INPUT TO DATA OUTPUT (RECEIVER)

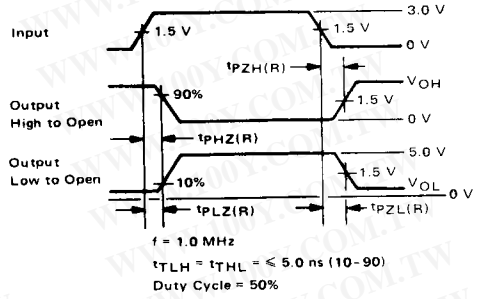
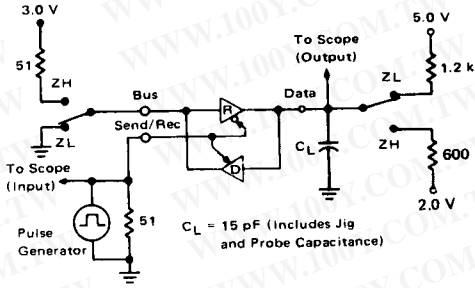

FIGURE 5 - TYPICAL RECEIVER HYSTERESIS CHARACTERISTICS

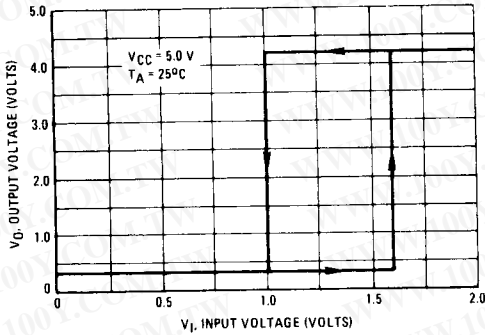

FIGURE 6 - TYPICAL BUS LOAD LINE

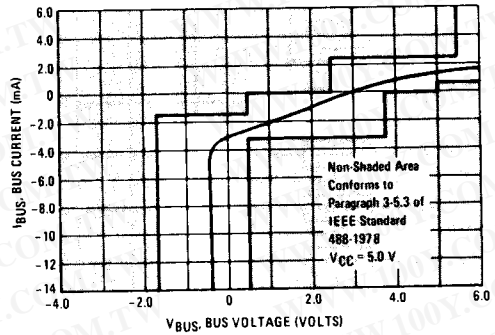
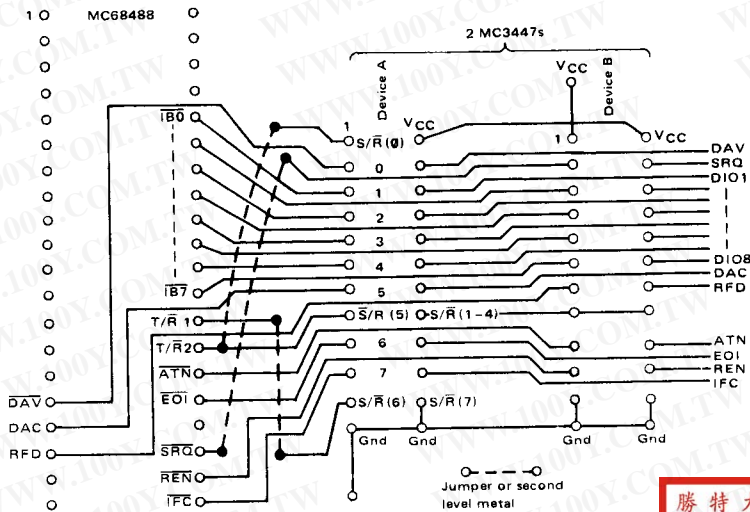

FIGURE 7 - SUGGESTED PRINTED CIRCUIT BOARD LAYOUT USING MC3447s AND MC68488



勝特力材料 886-3-5753170
 勝特力电子(上海) 86-21-54151736
 勝特力电子(深圳) 86-755-83298787
[Http://www.100y.com.tw](http://www.100y.com.tw)

MC3447

FIGURE 8 – SIMPLE SYSTEM CONFIGURATION

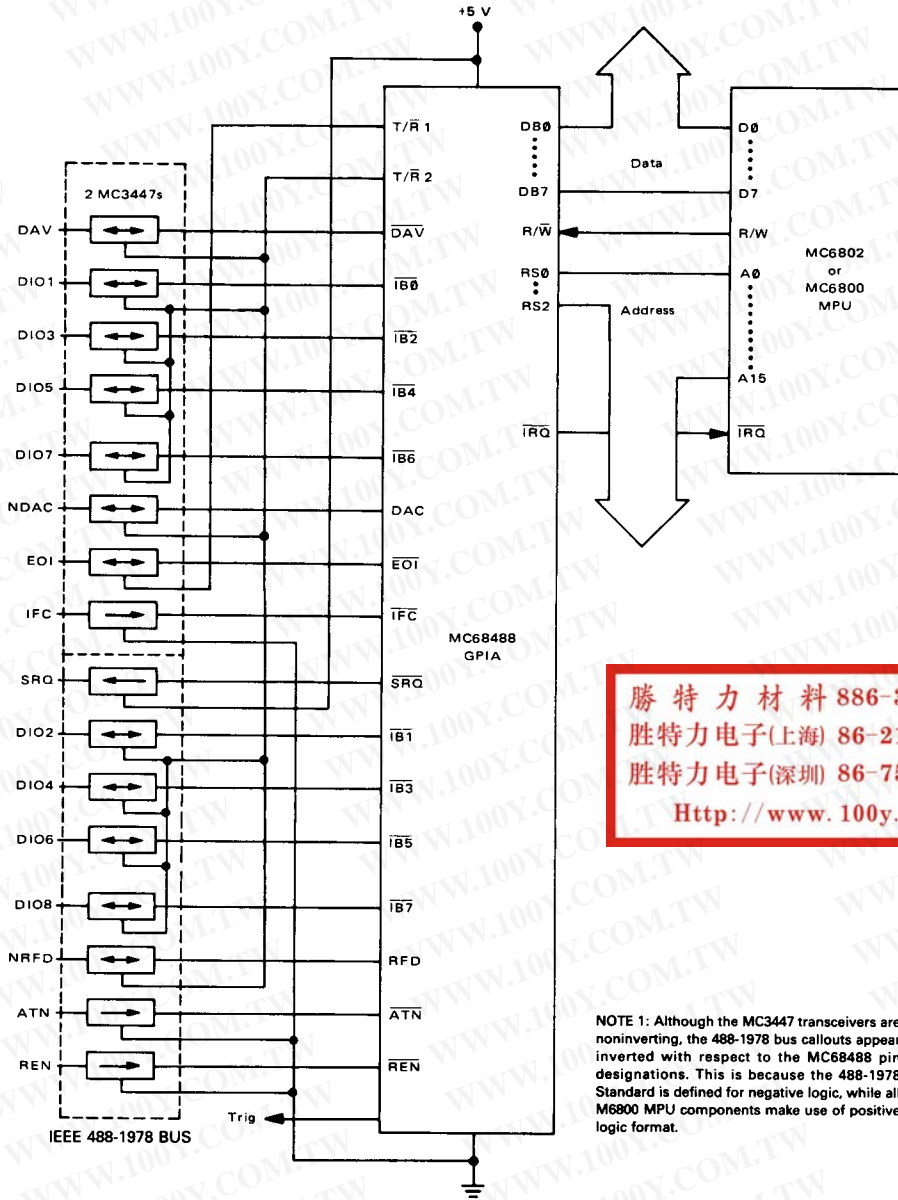

7

勝特力材料 886-3-5753170
 勝特力电子(上海) 86-21-54151736
 勝特力电子(深圳) 86-755-83298787
[Http://www.100y.com.tw](http://www.100y.com.tw)

NOTE 1: Although the MC3447 transceivers are noninverting, the 488-1978 bus callouts appear inverted with respect to the MC68488 pin designations. This is because the 488-1978 Standard is defined for negative logic, while all M6800 MPU components make use of positive logic format.

MC3447

FIGURE 9 – SUGGESTED PIN DESIGNATIONS FOR USE WITH MC68488

MC68488 Connections		MC3447 Pin Designations						MC68488 Connections	
A	B						A	B	
T/R 2	V _{CC}	S/R (0)	1	24	V _{CC}		V _{CC}	V _{CC}	
DAV	SRQ	Data 0 0	2	23	Bus 0		DAV	SRQ	
IB0	IB1	Data 1	3	22	Bus 1		DIO 1	DIO 2	
IB2	IB3	Data 2	4	21	Bus 2		DIO 3	DIO 4	
IB4	IB5	Data 3	5	20	Bus 3		DIO 5	DIO 6	
IB6	IB7	Data 4	6	19	Bus 4	Octal GPIB Transceiver	DIO 7	DIO 8	
DAC	RFD	Data 5	7	18	Bus 5		NDAC	NRFD	
T/R 2	T/R 2	S/R (5)	8	17	S/R (1-4)		T/R 2	T/R 2	
EOI	ATN	Data 6	9	16	Bus 6		EOI	ATN	
IFC	REN	Data 7	10	15	Bus 7		IFC	REN	
T/R 1	Gnd	S/R (6)	11	14	S/R (7)		Gnd	Gnd	
Gnd	Gnd	Logic Gnd	12	13	Bus Gnd		Gnd	Gnd	

7

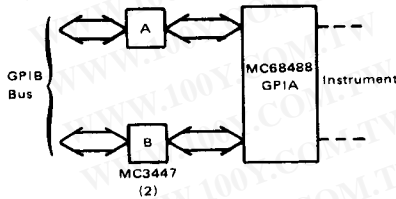

勝特力材料 886-3-5753170
 勝特力电子(上海) 86-21-54151736
 勝特力电子(深圳) 86-755-83298787
[Http://www.100y.com.tw](http://www.100y.com.tw)