

CAGE JACKS & MATING SOCKETS

ACCESSORIES
INFORMATION

REFER TO APPLICATION NOTE 11 FOR MOUNTING TECHNIQUES USING CAGE JACKS AND MATING SOCKETS

勝特力材料 886-3-5753170
勝特力电子(上海) 86-21-54151736
勝特力电子(深圳) 86-755-83298787
[Http://www.100y.com.tw](http://www.100y.com.tw)

MS03/MATING SOCKET .040" DIA. PINS — 8-PIN TO-3 PACKAGE

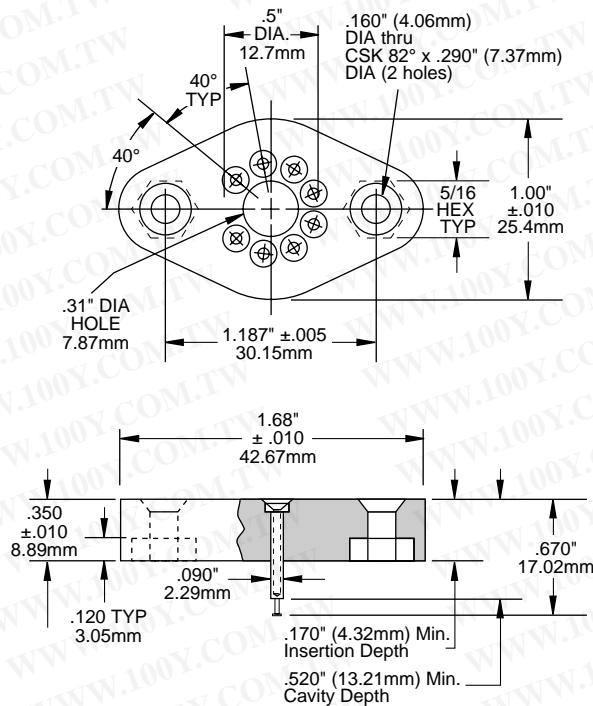

Contacts:

Resistance: .020Ω MAX

Contact Body: Brass

200/300μ in. Tin over 100/150μ in. Nickel

Inner Contact Clip: BeCu

30μ in. Gold over 50μ in. Nickel

Socket Body: Polyester, Glass Filled, 94 V₀-Rating

Color: Green

Operating Temperature Range: -55°C to +125°C

CAUTION

Combined heat and force during hand soldering plastic mating sockets can unseat pins and cause shorts to the header.