

REFER TO APPLICATION NOTE 11 FOR MOUNTING TECHNIQUES USING CAGE JACKS AND MATING SOCKETS

MS06/MATING SOCKET

.025" DIA. PINS—MO-127 HIGH VOLTAGE

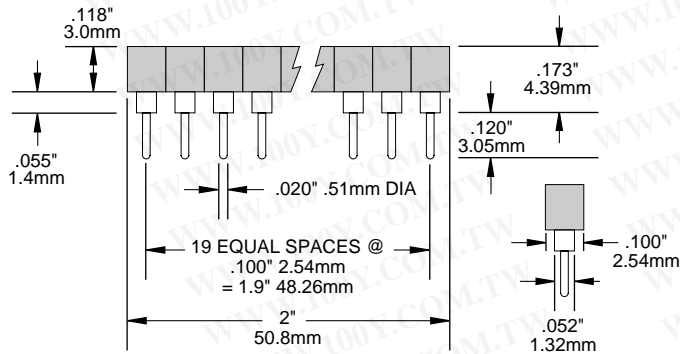

Body: Black polyester, glass filled
Contacts: Beryllium Copper
Shell: Half Hard Brass
PCB Hole: .035" ±.002", .889mm ±.051mm
Insulation Resistance: 5000 megohms minimum
Dielectric Withstanding Voltage: 500 volts AC
Flammability: UL 94V-0
Temperature Range: -65°C to +125°C

S = Solder Tail

TG = 10 μinch (.254μm) minimum

Gold on contact area

200 μinch (5.08 μm) minimum Tin on terminal area

50 μinch (1.27μm) minimum Nickel underplate

Also suitable for SIP10 packages.

Not suitable for SIP12 packages.

勝特力材料 886-3-5753170
勝特力电子(上海) 86-21-54151736
勝特力电子(深圳) 86-755-83298787
[Http://www.100y.com.tw](http://www.100y.com.tw)