

Chip EMIFIL® LC Combined Type

NFL21SP Series (0805 Size)

Dimension

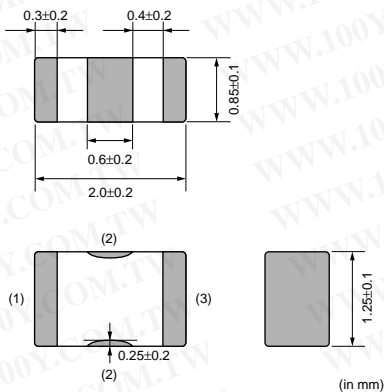

Insertion Loss Characteristics (Typical)

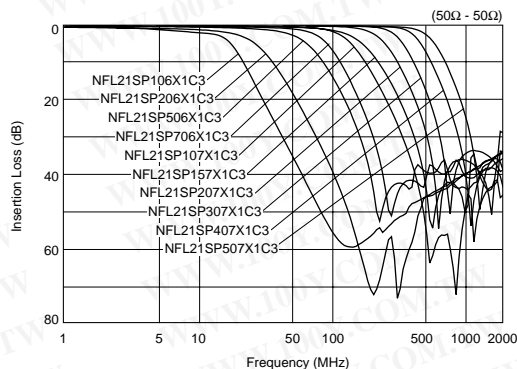

Equivalent circuit

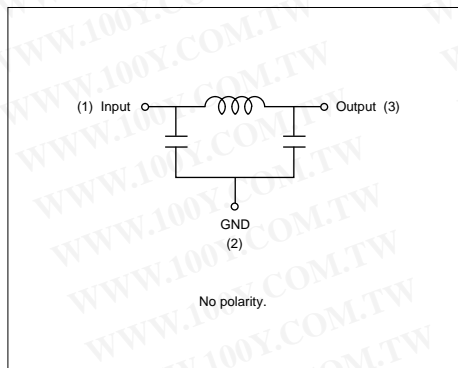

Packaging

Code	Packaging	Minimum Quantity
D	180mm Paper Tape	4000
B	Bulk(Bag)	1000

勝特力材料 886-3-5753170
 勝特力电子(上海) 86-21-54151736
 勝特力电子(深圳) 86-755-83298787
[Http://www.100y.com.tw](http://www.100y.com.tw)

Rated Value (□: packaging code)

Part Number	Cut-off Frequency	Capacitance	Inductance	Rated Voltage	Rated Current	Insulation Resistance (min.)	Operating Temperature Range	Case Size
NFL21SP106X1C3□	10MHz	670pF+20%-20%	680nH+20%-20%	16Vdc	100mA	1000M ohm	-55°C to 125°C	0805
NFL21SP206X1C3□	20MHz	240pF+20%-20%	700nH+20%-20%	16Vdc	100mA	1000M ohm	-55°C to 125°C	0805
NFL21SP506X1C3□	50MHz	84pF+20%-20%	305nH+20%-20%	16Vdc	150mA	1000M ohm	-55°C to 125°C	0805
NFL21SP706X1C3□	70MHz	76pF+20%-20%	185nH+20%-20%	16Vdc	150mA	1000M ohm	-55°C to 125°C	0805
NFL21SP107X1C3□	100MHz	44pF+20%-20%	135nH+20%-20%	16Vdc	200mA	1000M ohm	-55°C to 125°C	0805
NFL21SP157X1C3□	150MHz	28pF+20%-20%	128nH+20%-20%	16Vdc	200mA	1000M ohm	-55°C to 125°C	0805
NFL21SP207X1C3□	200MHz	22pF+20%-20%	72nH+20%-20%	16Vdc	250mA	1000M ohm	-55°C to 125°C	0805
NFL21SP307X1C3□	300MHz	19pF+10%-10%	45nH+10%-10%	16Vdc	300mA	1000M ohm	-55°C to 125°C	0805
NFL21SP407X1C3□	400MHz	16pF+10%-10%	34nH+10%-10%	16Vdc	300mA	1000M ohm	-55°C to 125°C	0805
NFL21SP507X1C3□	500MHz	12pF+10%-10%	31nH+10%-10%	16Vdc	300mA	1000M ohm	-55°C to 125°C	0805

Caution/Notice

Caution (Rating)

Do not use products beyond the rated current and rated voltage as this may create excessive heat and deteriorate the insulation resistance.

Notice

Solderability of Tin plating termination chip might be deteriorated when low temperature soldering profile where peak solder temperature is below the Tin melting point is used. Please confirm the solderability of Tin plating termination chip before use.

● This data sheet is applied for LC Combined CHIP EMIFIL® used for General Electronics equipment for your design.