

500mA, Low-Voltage Linear Regulator in μ MAX

General Description

The MAX1806 low-dropout linear regulator operates from a +2.25V to +5.5V supply and delivers a guaranteed 500mA load current with low 175mV dropout. The high-accuracy ($\pm 1\%$) output voltage is preset at an internally trimmed voltage (see *Selector Guide*) or can be adjusted from +0.8V to +4.5V with an external resistive-divider.

An internal PMOS pass transistor allows low 210 μ A supply current, making this device ideal for portable equipment such as personal digital assistants (PDAs), cellular phones, cordless phones, and other equipment, including base stations and docking stations.

Other features include an active-low, power-OK output that indicates when the output is out of regulation, a 0.02 μ A shutdown mode, short-circuit protection, and thermal shutdown protection. The MAX1806 comes in a miniature 1.3W, 8-pin power- μ MAX package with a metal pad on the underside of the package.

Applications

Notebook Computers
 Cellular and Cordless Telephones
 PDAs
 Palmtop Computers
 Base Stations
 USB Hubs
 Docking Stations

Typical Operating Circuit

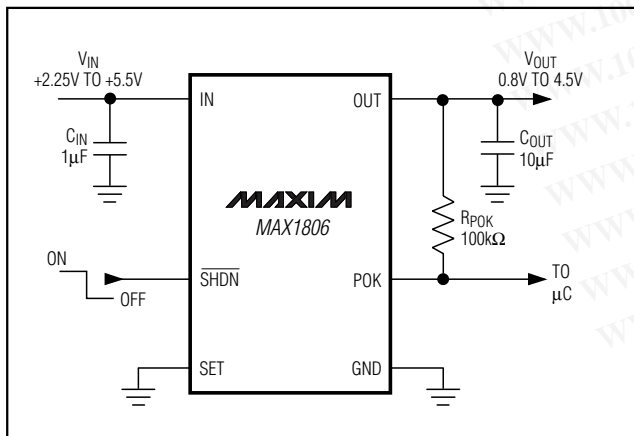

Features

- ◆ Guaranteed 500mA Output Current
- ◆ Output Down to 0.8V
- ◆ Low 175mV Dropout at 500mA
- ◆ $\pm 1\%$ Output Voltage Accuracy
 Preset at 0.8V, 1.5V, 1.8V, 2.5V, or 3.3V
 Adjustable from 0.8V to 4.5V
- ◆ Power-OK Output
- ◆ Low 210 μ A Ground Current
- ◆ 0.02 μ A Shutdown Current
- ◆ Thermal Overload Protection
- ◆ Output Current Limit
- ◆ Tiny 1.3W, 8-Pin Power- μ MAX Package

Ordering Information

PART	TEMP. RANGE	PIN-PACKAGE
MAX1806EUA_ _	-40°C to +85°C	8 Power- μ MAX

Selector Guide

PART AND SUFFIX	V _{OUT} (V)	TOP MARK
MAX1806EUA33	3.3	AAAG
MAX1806EUA25	2.5	AAAH
MAX1806EUA18	1.8	AAAI
MAX1806EUA15	1.5	AAAJ
MAX1806EUA08	0.8	AAAK

Pin Configuration

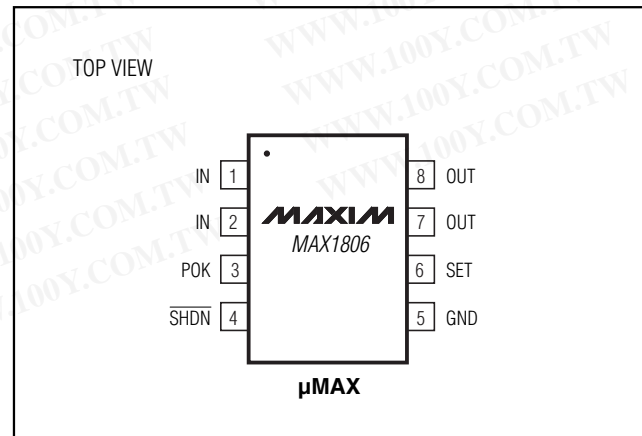

500mA, Low-Voltage Linear Regulator in μ MAX

MAX1806

ABSOLUTE MAXIMUM RATINGS

IN, $\overline{\text{SHDN}}$, POK, SET to GND-0.3V to +6V
 OUT to GND-0.3V to ($V_{\text{IN}} + 0.3\text{V}$)
 Output Short-Circuit Duration.....Continuous
 Continuous Power Dissipation ($T_A = +70^\circ\text{C}$)
 8-Pin Power- μ MAX (derate 17mW/ $^\circ\text{C}$ above $+70^\circ\text{C}$).....1.3W

Operating Temperature-40 $^\circ\text{C}$ to +85 $^\circ\text{C}$
 Junction Temperature+150 $^\circ\text{C}$
 Storage Temperature Range-65 $^\circ\text{C}$ to +150 $^\circ\text{C}$
 Lead Temperature (soldering, 10s)+300 $^\circ\text{C}$

Stresses beyond those listed under "Absolute Maximum Ratings" may cause permanent damage to the device. These are stress ratings only, and functional operation of the device at these or any other conditions beyond those indicated in the operational sections of the specifications is not implied. Exposure to absolute maximum rating conditions for extended periods may affect device reliability.

ELECTRICAL CHARACTERISTICS

($V_{\text{IN}} = V_{\text{OUT}}(\text{SETPOINT}) + 500\text{mV}$ or $V_{\text{IN}} = +2.25\text{V}$ whichever is greater, SET = GND, $\overline{\text{SHDN}} = \text{IN}$, $T_A = 0^\circ\text{C}$ to +85 $^\circ\text{C}$, unless otherwise noted. Typical values are at $T_A = +25^\circ\text{C}$.)

PARAMETER	SYMBOL	CONDITIONS	MIN	TYP	MAX	UNITS
Input Voltage	V_{IN}		2.25		5.5	V
Input Undervoltage Lockout	V_{UVLO}	Rising, 40mV hysteresis	1.85	2.0	2.15	V
Output Voltage Accuracy (Preset Mode)	V_{OUT}	$T_A = +85^\circ\text{C}$, $I_{\text{OUT}} = 100\text{mA}$	-1		+1	%
		$T_A = +85^\circ\text{C}$, $I_{\text{OUT}} = 1\text{mA}$ to 500mA	-1.5		+1.5	
		$T_A = 0^\circ\text{C}$ to +85 $^\circ\text{C}$, $I_{\text{OUT}} = 1\text{mA}$ to 500mA, $V_{\text{IN}} > V_{\text{OUT}} + 0.5\text{V}$	-3		+3	
Adjustable Output Voltage			0.8		4.5	V
SET Voltage Threshold (Adjustable Mode)	V_{SET}	$T_A = +85^\circ\text{C}$, $I_{\text{OUT}} = 100\text{mA}$	790		810	mV
		$T_A = +85^\circ\text{C}$, $I_{\text{OUT}} = 1\text{mA}$ to 500mA	786		814	
		$T_A = 0^\circ\text{C}$ to +85 $^\circ\text{C}$, $I_{\text{OUT}} = 1\text{mA}$ to 500mA, $V_{\text{IN}} > V_{\text{OUT}} + 0.5\text{V}$	774	800	826	
Maximum Output Current	I_{OUT}		500			mARMS
Short-Circuit Current Limit	I_{LIM}	$V_{\text{OUT}} = 0\text{V}$	700	1400	2300	mA
SET Dual Mode™ Threshold			35	80	125	mV
SET Input Bias Current	I_{SET}	$V_{\text{SET}} = +0.8\text{V}$	-100		+100	nA
Ground-Pin Current	I_{Q}	$I_{\text{OUT}} = 1\text{mA}$		210	400	μA
		$I_{\text{OUT}} = 500\text{mA}$		575		
Dropout Voltage (Note 1)		$I_{\text{OUT}} = 500\text{mA}$	$V_{\text{OUT}} = +2.25\text{V}$	259	384	mV
			$V_{\text{OUT}} = +2.8\text{V}$	201	315	
			$V_{\text{OUT}} = +4.0\text{V}$	147	255	
Line Regulation	ΔV_{LNR}	V_{IN} from ($V_{\text{OUT}} + 100\text{mV}$) to 5.5V, $I_{\text{LOAD}} = 5\text{mA}$		0	0.125	%/V
Load Regulation	ΔV_{LDR}	$I_{\text{OUT}} = 1\text{mA}$ to 500mA		15.5	35	ppm/mA
Output Voltage Noise		10Hz to 1MHz, $C_{\text{OUT}} = 10\mu\text{F}$ (ESR < 0.1 Ω)		300		μVRMS
SHUTDOWN						
Shutdown Supply Current	I_{OFF}	$\overline{\text{SHDN}} = \text{GND}$, $V_{\text{IN}} = 5.5\text{V}$		0.02	5	μA
$\overline{\text{SHDN}}$ Input Threshold	V_{IH}		1.6			V
	V_{IL}				0.6	
$\overline{\text{SHDN}}$ Input Bias Current	I_{SHDN}	$\overline{\text{SHDN}} = \text{GND}$ or IN		10	100	nA
Startup Time	T_{START}	$C_{\text{OUT}} = 10\mu\text{F}$, time from $\overline{\text{SHDN}}$ high to POK high		40		μs

Dual Mode is a trademark of Maxim Integrated Products, Inc.

500mA, Low-Voltage Linear Regulator in μ MAX

ELECTRICAL CHARACTERISTICS (continued)

($V_{IN} = V_{OUT(SETPOINT)} + 500mV$ or $V_{IN} = +2.25V$ whichever is greater, SET = GND, $\overline{SHDN} = IN$, $T_A = 0^\circ C$ to $+85^\circ C$, unless otherwise noted. Typical values are at $T_A = +25^\circ C$.)

PARAMETER	SYMBOL	CONDITIONS	MIN	TYP	MAX	UNITS
POWER-OK						
POK Output Low Voltage	V_{OL}	Sinking 2mA		5	50	mV
Operating Voltage Range for Valid POK Output		Sinking 100 μ A	1.0		5.5	V
Output High-Leakage Current		$V_{POK} = +5.5V$			100	nA
Threshold		Rising edge, referred to $V_{OUT(NOMINAL)}$	90	93	96	%
THERMAL PROTECTION						
Thermal Shutdown Temperature	T_{SHDN}			170		$^\circ C$
Thermal Shutdown Hysteresis	ΔT_{SHDN}			20		$^\circ C$

ELECTRICAL CHARACTERISTICS

($V_{IN} = V_{OUT(SETPOINT)} + 500mV$ or $V_{IN} = +2.25V$ whichever is greater, SET = GND, $\overline{SHDN} = IN$, $T_A = -40^\circ C$ to $+85^\circ C$, unless otherwise noted. Typical values are at $T_A = +25^\circ C$.) (Note 2)

PARAMETER	SYMBOL	CONDITIONS	MIN	TYP	MAX	UNITS
Input Voltage	V_{IN}		2.25		5.5	V
Input Undervoltage Lockout	V_{UVLO}	Rising, 40mV hysteresis	1.85		2.15	V
Output Voltage Accuracy (Preset Mode)	V_{OUT}	$I_{OUT} = 1mA$ to 500mA	-4		+4	%
Adjustable Output Voltage			0.8		4.5	V
SET Voltage Threshold (Adjustable Mode)	V_{SET}	$I_{OUT} = 1mA$ to 500mA	766		834	mV
Maximum Output Current	I_{OUT}		500			mARMS
Short-Circuit Current Limit	I_{LIM}	$V_{OUT} = 0V$	700		2500	mA
SET Dual Mode™ Threshold			35		125	mV
SET Input Bias Current	I_{SET}	$V_{SET} = +0.8V$	-100		+100	nA
Ground-Pin Current	I_Q	$I_{OUT} = 1mA$			400	μA
Dropout Voltage (Note 1)		$I_{OUT} = 500mA$	$V_{OUT} = +2.25V$	259	384	mV
			$V_{OUT} = +2.8V$	201	315	
			$V_{OUT} = +4.0V$	147	255	
Line Regulation	ΔV_{LNR}	V_{IN} from ($V_{OUT} + 100mV$) to 5.5V, $I_{LOAD} = 5mA$	-0.175		+0.175	%/V
Load Regulation	ΔV_{LDR}	$I_{OUT} = 1mA$ to 500mA			35	ppm/mA
SHUTDOWN						
Shutdown Supply Current	I_{OFF}	$\overline{SHDN} = GND$, $V_{IN} = 5.5V$			5	μA
\overline{SHDN} Input Threshold	V_{IH}	$2.5V < V_{IN} < 5.5V$	1.6			V
	V_{IL}	$2.5V < V_{IN} < 5.5V$			0.6	
\overline{SHDN} Input Bias Current	I_{SHDN}	$\overline{SHDN} = GND$ or IN			100	nA

500mA, Low-Voltage Linear Regulator in μ MAX

MAX1806

ELECTRICAL CHARACTERISTICS (continued)

($V_{IN} = V_{OUT(SETPOINT)} + 500\text{mV}$ or $V_{IN} = +2.25\text{V}$ whichever is greater, SET = GND, $\overline{\text{SHDN}} = \text{IN}$, $T_A = -40^\circ\text{C}$ to $+85^\circ\text{C}$, unless otherwise noted. Typical values are at $T_A = +25^\circ\text{C}$.) (Note 2)

PARAMETER	SYMBOL	CONDITIONS	MIN	TYP	MAX	UNITS
POWER-OK						
POK Output Low Voltage	V_{OL}	Sinking 2mA			50	mV
Operating Voltage Range for Valid POK Output		Sinking 100 μ A	1.0		5.5	V
Output High-Leakage Current		$V_{POK} = +5.5\text{V}$			100	nA
Threshold		Rising edge, referred to $V_{OUT(NOMINAL)}$	89		97	%

Note 1: Dropout voltage is defined as $V_{IN} - V_{OUT}$, when V_{OUT} is 100mV below the value of V_{OUT} and when $V_{IN} = V_{OUT(NOM)} + 0.5\text{V}$. For $2.25\text{V} \leq V_{OUT} \leq 4.0\text{V}$, dropout voltage limits are linearly interpolated from the values listed. For $V_{OUT} < 4.0\text{V}$, dropout voltage limit is equal to the value for $V_{OUT} = 4.0\text{V}$.

Note 2: Specifications to -40°C are guaranteed by design, not production tested.

Typical Operating Characteristics

(MAX1806EUA33, $V_{IN} = V_{OUT} + 500\text{mV}$, $\overline{\text{SHDN}} = \text{IN}$, $C_{IN} = 1\mu\text{F}$, $C_{OUT} = 10\mu\text{F}$, $T_A = +25^\circ\text{C}$, unless otherwise noted.)

OUTPUT VOLTAGE vs. INPUT VOLTAGE

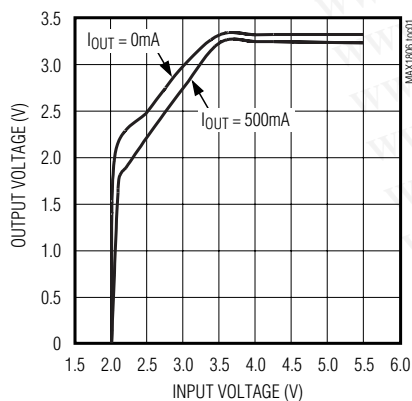

OUTPUT VOLTAGE vs. LOAD CURRENT

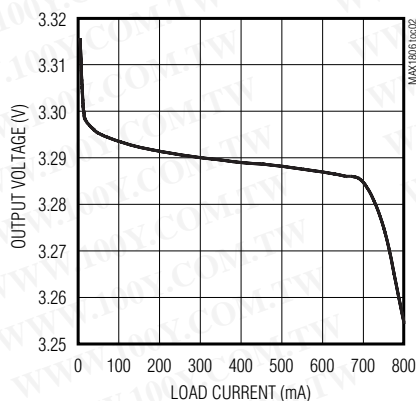

OUTPUT VOLTAGE vs. TEMPERATURE

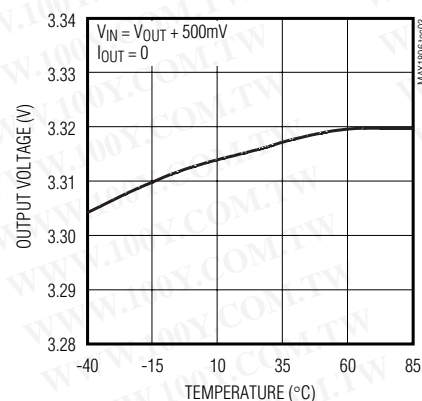

DROPOUT VOLTAGE vs. LOAD CURRENT

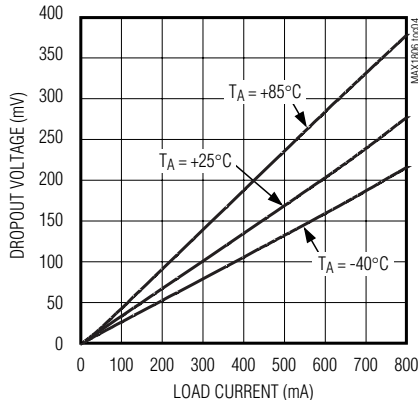

DROPOUT VOLTAGE vs. OUTPUT VOLTAGE

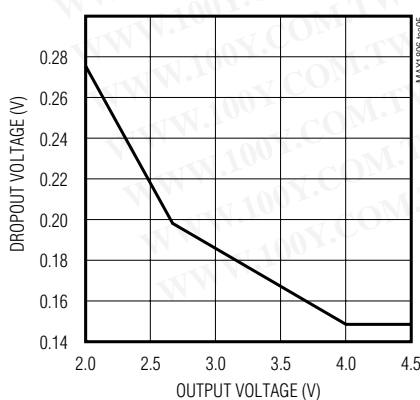

GROUND-PIN CURRENT vs. INPUT VOLTAGE

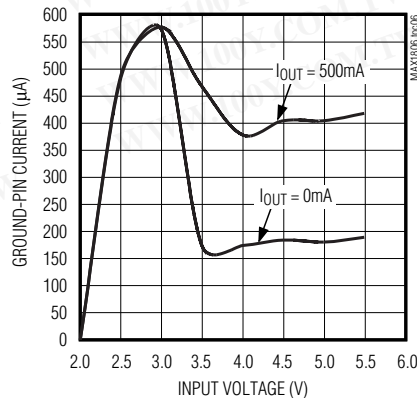

500mA, Low-Voltage Linear Regulator in μ MAX

Typical Operating Characteristics (continued)

(MAX1806EUA33, $V_{IN} = V_{OUT} + 500\text{mV}$, $\text{SHDN} = \text{IN}$, $C_{IN} = 1\mu\text{F}$, $C_{OUT} = 10\mu\text{F}$, $T_A = +25^\circ\text{C}$, unless otherwise noted.)

MAX1806

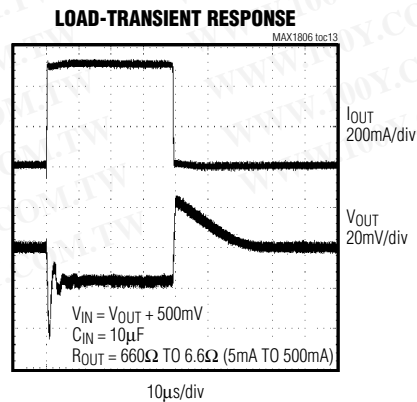
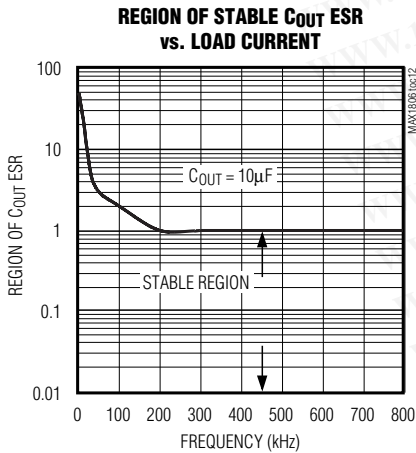
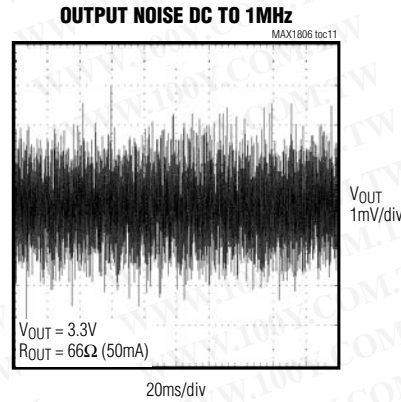
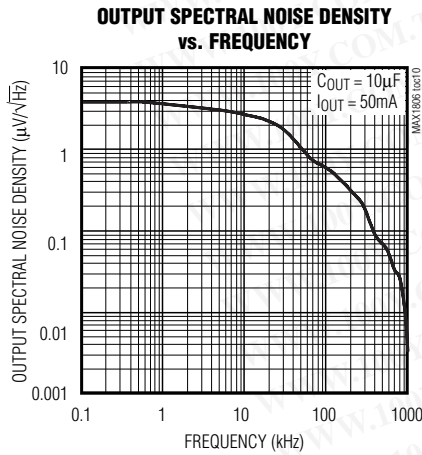
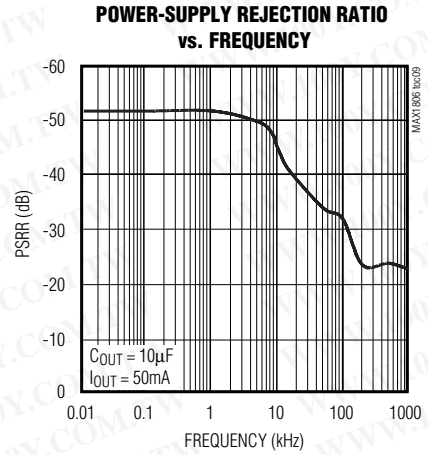
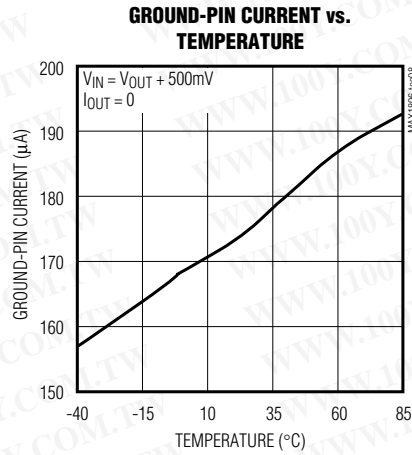
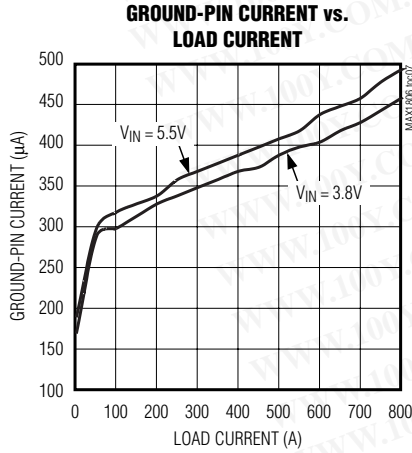

500mA, Low-Voltage Linear Regulator in μ MAX

Typical Operating Characteristics (continued)

(MAX1806EUA33, $V_{IN} = V_{OUT} + 500\text{mV}$, $\overline{\text{SHDN}} = \text{IN}$, $C_{IN} = 1\mu\text{F}$, $C_{OUT} = 10\mu\text{F}$, $T_A = +25^\circ\text{C}$, unless otherwise noted.)

**LOAD-TRANSIENT RESPONSE
NEAR DROPOUT**

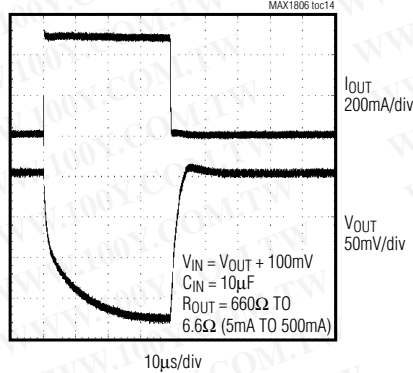

LINE-TRANSIENT RESPONSE

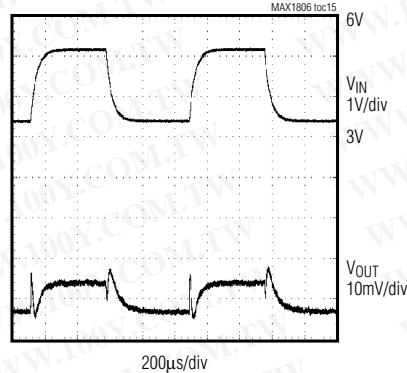

SHUTDOWN WAVEFORM

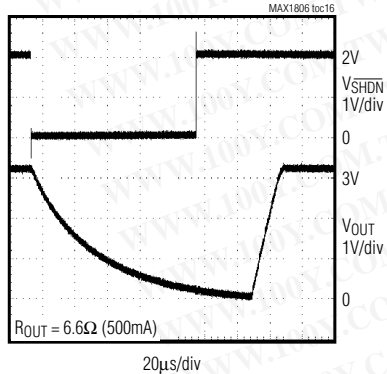

POK WAVEFORM

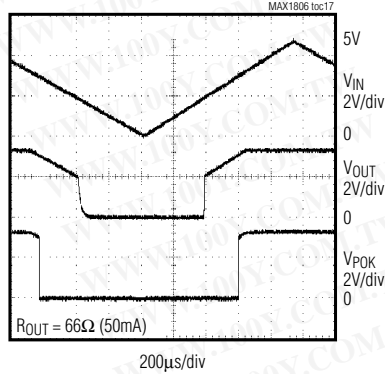

Pin Description

PIN	NAME	FUNCTION
1, 2	IN	Regulator Input. Supply voltage can range from +2.25V to +5.5V. Bypass with a $1\mu\text{F}$ capacitor to GND (see <i>Capacitor Selection and Regulation Stability</i>). Connect both input pins together externally.
3	POK	Open-Drain, Active-Low Power-OK Output. POK remains low while the output voltage (V_{OUT}) is below the POK threshold. Connect a $100\text{k}\Omega$ pullup resistor from POK to OUT.
4	$\overline{\text{SHDN}}$	Active-Low Shutdown Input. A logic low at $\overline{\text{SHDN}}$ reduces supply current to $0.02\mu\text{A}$. In shutdown, the POK output is low. Connect $\overline{\text{SHDN}}$ to IN for normal operation.
5	GND	Ground. This pin and the exposed pad also function as a heatsink. Solder both to a large pad or to the circuit-board ground plane to maximize power dissipation.
6	SET	Voltage-Setting Input. Connect SET to GND for preset output. Connect an external resistive voltage-divider from OUT to SET to set the output voltage between 0.8V and 4.5V. The SET regulation voltage is 800mV.
7, 8	OUT	Regulator Output. OUT sources up to 500mA. Bypass OUT with a $10\mu\text{F}$ low-ESR capacitor to GND. Connect both OUT pins together externally.

500mA, Low-Voltage Linear Regulator in μ MAX

Detailed Description

The MAX1806 is a low-dropout, low-quiescent-current linear regulator. The device supplies loads up to 500mA and is available with preset output voltages. As illustrated in Figure 1, the MAX1806 includes a 0.8V reference, error amplifier, P-channel pass transistor, and internal feedback voltage-divider.

The reference is connected to the error amplifier, which compares it with the feedback voltage and amplifies the difference. If the feedback voltage is lower than the reference voltage, the pass-transistor gate is pulled lower, which allows more current to pass to the output increasing the output voltage. If the feedback voltage is too high, the pass-transistor gate is pulled up, allowing less current to pass to the output.

The output voltage is fed back through either an internal resistive voltage-divider connected to OUT or an external resistor network connected to SET. The dual-mode comparator examines V_{SET} and selects the feedback path. If V_{SET} is below 35mV, the internal feedback path is used, and the output is regulated to the factory-preset voltage. Additional blocks include an output current limiter, thermal sensor, and shutdown logic.

Internal P-Channel Pass Transistor

The MAX1806 features a 0.4 Ω P-channel MOSFET pass transistor. Unlike similar designs using PNP pass transistors, P-channel MOSFETs require no base drive, which reduces operating current. PNP-based regulators also waste considerable current in dropout when the pass transistor saturates, and use high base-drive currents under large loads. The MAX1806 does not suffer from these problems.

Output Voltage Selection

The MAX1806's dual-mode operation allows operation in either a preset voltage mode or an adjustable mode. Connect SET to GND to select the preset output voltage. The two-digit part number suffix identifies the output voltage (see *Selector Guide*). For example, the MAX1806EUA33 has a preset 3.3V output voltage. The output voltage may also be adjusted by connecting a voltage-divider from OUT to SET (Figure 2). Select R2 in the 25k Ω to 100k Ω range. Calculate R1 with the following equation:

$$R1 = R2 [(V_{OUT} / V_{SET}) - 1]$$

where $V_{SET} = 0.8V$, and V_{OUT} may range from 0.8V to 4.5V.

Shutdown

Drive \overline{SHDN} low to enter shutdown. During shutdown, the output is disconnected from the input, and supply

current drops to 0.02 μA . When in shutdown, POK pulls low. The capacitance and load at OUT determine the rate at which V_{OUT} decays. \overline{SHDN} can be pulled as high as +6V, regardless of the input and output voltage.

Power-OK Output

The POK output pulls low when OUT is less than 93% of the nominal regulation voltage. Once OUT exceeds 93% of the nominal voltage, POK goes high impedance. POK is an open-drain N-channel output. To obtain a logic voltage output, connect a pullup resistor from POK to OUT. A 100k Ω resistor works well for most applications. POK can be used to signal a microcontroller (μC), or drive an external LED to indicate power failure. When the MAX1806 is shutdown, POK is held low independent of the output voltage. If unused, leave POK grounded or unconnected.

Current Limit

The MAX1806 monitors and controls the pass transistor's gate voltage, limiting the output current to 1.4A (typ). The output can be shorted to ground for an indefinite period of time without damaging the part.

Thermal Overload Protection

Thermal overload protection limits total power dissipation in the MAX1806. When the junction temperature exceeds $T_J = +170^{\circ}C$, a thermal sensor turns off the pass transistor, allowing the device to cool. The thermal sensor turns the pass transistor on again after the junction temperature cools by 20 $^{\circ}C$, resulting in a pulsed output during continuous thermal overload conditions. Thermal overload protection protects the MAX1806 in the event of fault conditions. For continuous operation, do not exceed the absolute maximum junction-temperature rating of $T_J = +150^{\circ}C$.

Operating Region and Power Dissipation

The MAX1806's maximum power dissipation depends on the thermal resistance of the IC package and circuit board, the temperature difference between the die junction and ambient air, and the rate of air flow. The power dissipated in the device is $P = I_{OUT} \times (V_{IN} - V_{OUT})$. The maximum allowed power dissipation is 1.3W or:

$$P_{MAX} = (T_{J(MAX)} - T_A) / (\theta_{JC} + \theta_{CA})$$

where $T_J - T_A$ is the temperature difference between the MAX1806 die junction and the surrounding air, θ_{JC} is the thermal resistance from the junction to the case, and θ_{CA} is the thermal resistance from the case through the PC board, copper traces, and other materials to the surrounding air. The MAX1806 package features an exposed thermal pad on its underside. This pad lowers the package's thermal resistance by provid-

500mA, Low-Voltage Linear Regulator in μ MAX

MAX1806

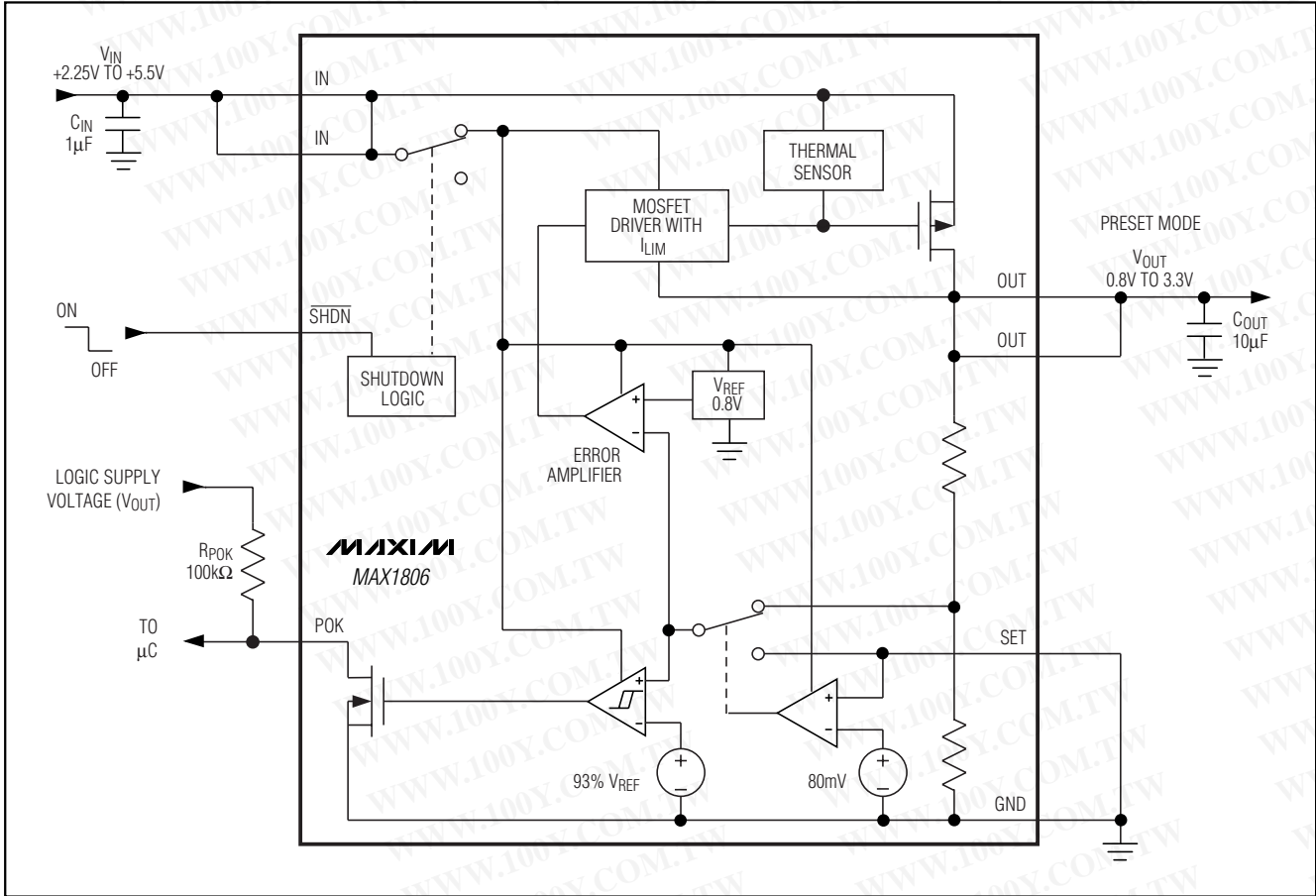

Figure 1. Functional Diagram

ing a direct heat conduction path from the die to the PC board. Connect the exposed backside pad and GND to the system ground using a large pad or ground plane, or multiple vias to the ground plane layer.

The MAX1806 delivers up to 0.5A(RMS) and operates with input voltages up to 5.5V, but not simultaneously. High output currents can only be sustained when input-output differential is within the limits outlined.

Applications Information

Capacitor Selection and Regulator Stability

Connect a 1µF capacitor between IN and ground and a 10µF low equivalent series resistance (ESR) capacitor between OUT and ground. The input capacitor (C_{IN}) lowers the source impedance of the input supply. Reduce noise and improve load-transient response, stability, and power-supply rejection by using larger

output capacitors. The output capacitor's (C_{OUT}) ESR affects stability and output noise. Use output capacitors with an ESR of 0.1Ω or less to ensure stability and optimum transient response. Surface-mount ceramic capacitors have very low ESR and are commonly available in values up to 10µF. Connect C_{IN} and C_{OUT} as close to the MAX1806 as possible.

Noise, PSRR, and Transient Response

The MAX1806 is designed to operate with low dropout voltages and low quiescent currents, while still maintaining good noise, transient response, and AC rejection. See the *Typical Operating Characteristics* for a plot of Power-Supply Rejection Ratio (PSRR) vs. Frequency. When operating from noisy sources, improved supply-noise rejection and transient response can be achieved by increasing the values of the input and output bypass capacitors and through passive-filtering techniques. The MAX1806 load-transient

500mA, Low-Voltage Linear Regulator in μ MAX

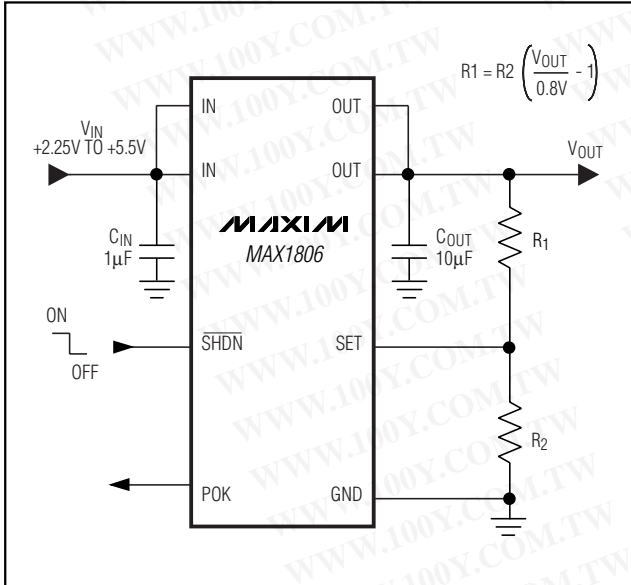

Figure 2. Adjustable Output Using External Feedback Resistors

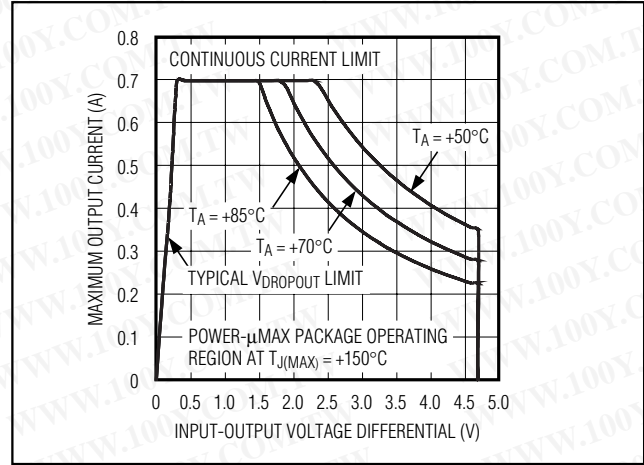

Figure 3. Power Operating Regions: Maximum Output Current vs. Supply Voltage

MAX1806

response graphs (see *Typical Operating Characteristics*) show two components of the output response: a DC shift from the output impedance due to the load current change, and the transient response. A typical transient overshoot for a step change in the load current from 5mA to 500mA is 40mV. Increasing the output capacitor's value and decreasing the ESR attenuates the overshoot.

Input-Output (Dropout) Voltage

A regulator's minimum input-to-output voltage differential (dropout voltage) determines the lowest usable supply voltage. In battery-powered systems, this determines the useful end-of-life battery voltage. Because the MAX1806 uses a P-channel MOSFET pass transistor, its dropout voltage is a function of drain-to-source on-resistance ($R_{DS(ON)}$) multiplied by the load current (see *Typical Operating Characteristics*):

$$V_{DROPOUT} = V_{IN} - V_{OUT} = R_{DS(ON)} \times I_{OUT}$$

Chip Information

TRANSISTOR COUNT: 949

500mA, Low-Voltage Linear Regulator in μ MAX

Package Information

MAX1806

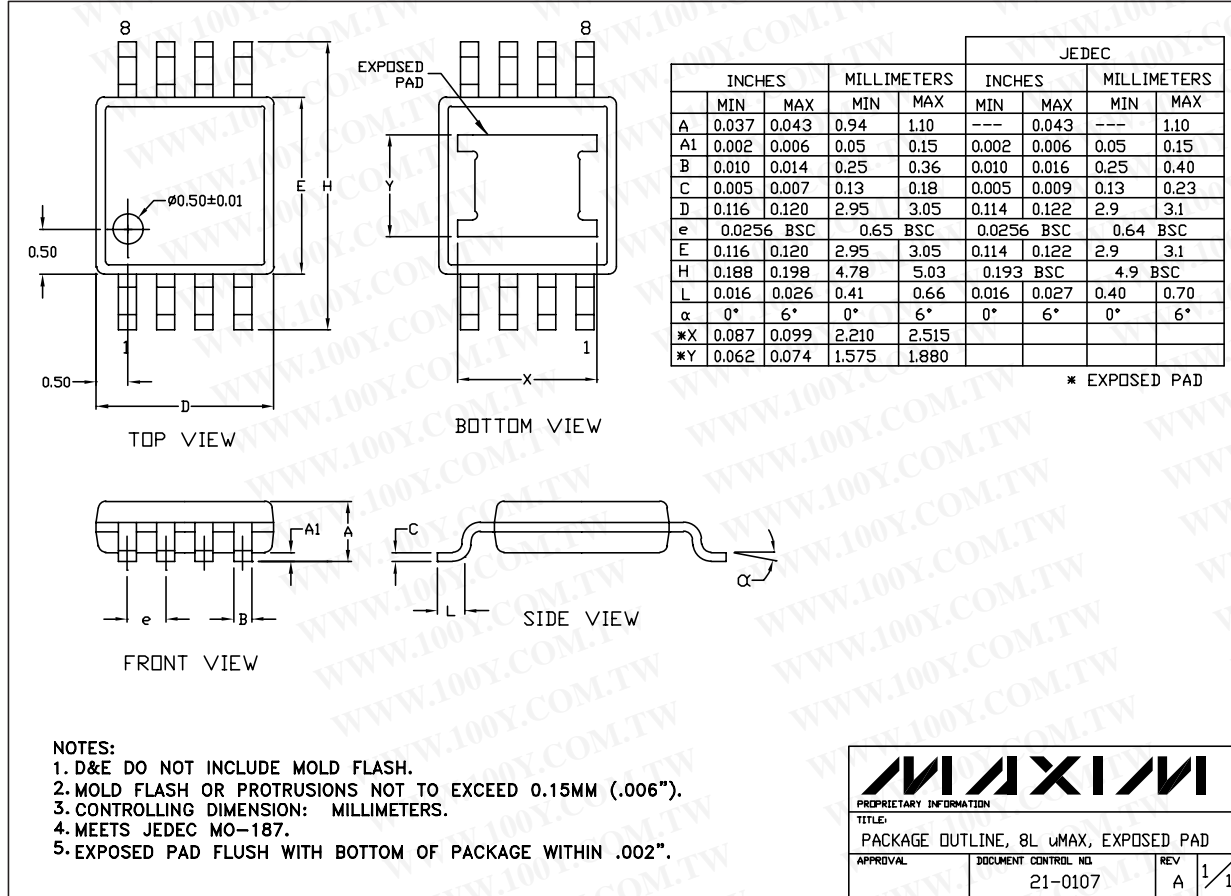

8L μ MAX, EXP PAD EPS

Note: The MAX1806 has an exposed thermal pad on the bottom side of the package.

Maxim cannot assume responsibility for use of any circuitry other than circuitry entirely embodied in a Maxim product. No circuit patent licenses are implied. Maxim reserves the right to change the circuitry and specifications without notice at any time.

10 Maxim Integrated Products, 120 San Gabriel Drive, Sunnyvale, CA 94086 408-737-7600