

# Vernier Height Gage

## SERIES 514 — Standard Height Gage with adjustable Main Scale

### FEATURES

- Zero reference point can be adjusted.
- Stain chrome finished scales for glare-free reading.
- Extra-large base for rigidity.
- Final vernier readings can be assisted by an optional magnifier.
- Carbide-tipped scriber is provided.

勝特力材料 886-3-5753170  
 勝特力电子(上海) 86-21-54151736  
 勝特力电子(深圳) 86-755-83298787  
[Http://www.100y.com.tw](http://www.100y.com.tw)

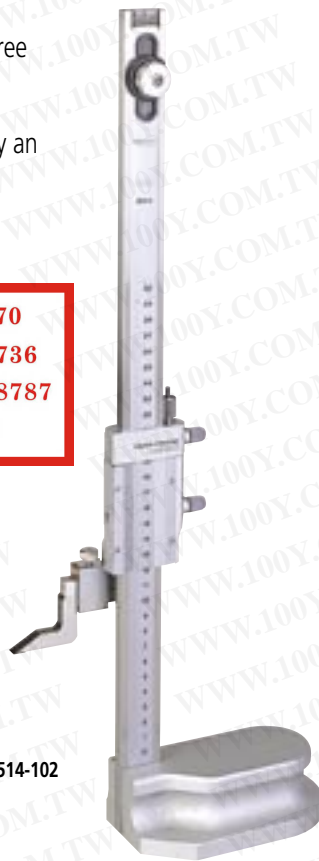

514-102

### SPECIFICATIONS

Metric							
Range	Order No.	Accuracy	Remarks (R / L scale graduations / scale adjustment / slider fine feed / others)				
0 - 300mm	514-102	±0.04mm	0.02mm	—	15mm	4mm	—
0 - 450mm	514-104	±0.05mm	0.02mm	—	15mm	4mm	—
0 - 600mm	514-106	±0.05mm	0.02mm	—	15mm	7mm	—
0 - 1000mm	514-108	±0.07mm	0.02mm	—	25mm	6mm	—
0 - 1500mm	514-170	±0.18mm	0.02mm	—	25mm	20mm	Provided with magnifier

Inch/Metric							
Inch model with inch/metric double scale							
Range	Order No.	Accuracy	Remarks (R / L scale graduations / scale adjustment / slider fine feed / others)				
0 - 12"	514-103	±.002"	.001"	0.02mm	.6"	.16"	—
0 - 18"	514-105	±.002"	.001"	0.02mm	.6"	.16"	—
0 - 24"	514-107	±.002"	.001"	0.02mm	.6"	.27"	—
0 - 40"	514-109	±.003"	.001"	0.02mm	1"	.24"	—

### DIMENSION

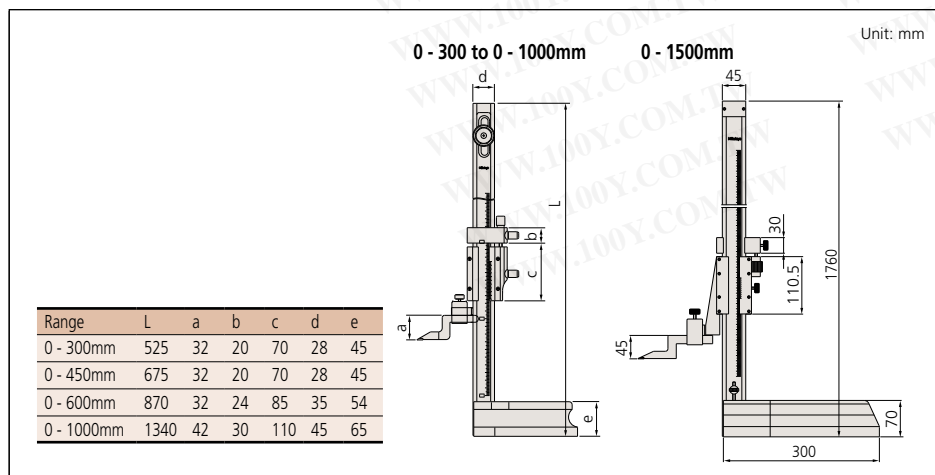

### Technical Data

Accuracy: ±0.04mm (≤300mm), ±0.05mm (≤600mm), ±0.07mm (≤1000mm), ±0.18mm (≤1500mm)  
 Graduation: 0.02mm or .001" (0.02mm)  
 Main scale adjustment: 15mm or 25mm  
 Slider fine feed: 4mm, 6mm, 7mm or 20mm

### Standard Scriber Provided

Up to 600mm: Carbide-tipped scriber (07GZA000) and scriber clamp (05GZA033)  
 0 - 1000mm: Carbide-tipped scriber (905200) and scriber clamp (05GZA033)  
 0 - 1500mm: Carbide-tipped scriber (900390) and scriber clamp (905008)

### Dimension of scriber

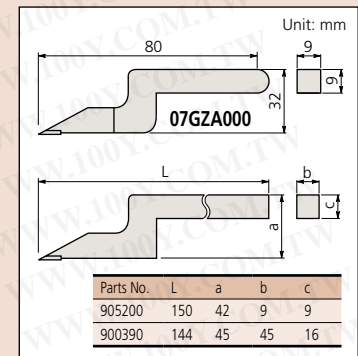

### Optional Accessory

07GZA003: Magnifier for 300, 450mm, 600mm models  
 07GZA015: Magnifier for 1000mm models  
 953638: Holding bar for test indicator (length: 50mm)  
 902053: Swivel clamp used with holding bar



	型號 Order	<i>514-103</i>	
	中文名稱 Product Name	<i>鑄座高度計</i>	
	型式 Type	<i>游標式</i>	
	公/英制 Metric / Inch	<i>公/英制</i>	
範圍(公制) Range in Metric	<i>0-300mm</i>	範圍(英制) Range in Inch	<i>0-12"</i>
解析度(公制) Resolution in Metric	<i>0.02mm</i>	解析度(英制) Resolution in Inch	<i>0.001"</i>
準確度(公制) Accuracy in Metric	<i>±0.04mm</i>	準確度(英制) Accuracy in Inch	<i>±0.002"</i>
輸出功能 Output	<i>無</i>	1m / 2m 輸出線型號	<i>- / -</i>
價格 Price	<i>詢價</i>	備考 Remark	

勝特力材料 886-3-5753170  
 勝特力电子(上海) 86-21-54151736  
 勝特力电子(深圳) 86-755-83298787  
[Http://www.100y.com.tw](http://www.100y.com.tw)