

## 10 AMP POWER RELAY

## HP RELAYS

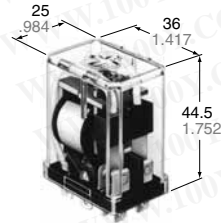

mm inch

### FEATURES

- Interchangeable with existing models
- Long life and high reliability
- High contact capacity up to 10 A 250 V AC
- Available with plug-in/solder and quick-connect terminals

勝特力材料 886-3-5753170  
 胜特力电子(上海) 86-21-54151736  
 胜特力电子(深圳) 86-755-83298787  
[Http://www.100y.com.tw](http://www.100y.com.tw)

**RoHS Directive compatibility information**  
<http://www.nais-e.com/>

### About Cd-free contacts

We have introduced Cadmium free type products to reduce Environmental Hazardous Substances.

(The suffix "F" should be added to the part number)  
 (Note: The Suffix "F" is required only for 4 Form C contact type. The 2 Form C and 3 Form C contact type is originally Cadmium free, the suffix "F" is not required.)

Please replace parts that contain Cadmium with Cadmium-free products and evaluate them with your actual application before use because the life of a relay depends on the contact material and load.

## SPECIFICATIONS (at 20°C 68°F)

### Contacts

Arrangement		2 Form C	3 Form C	4 Form C
Initial contact resistance, max. (By voltage drop 6 V DC 1 A)		15 mΩ		
Contact material		Silver		Silver alloy (cadmium free)
Rating	Nominal switching capacity	10 A 250 V AC (resistive)		
	Min. switching capacity <sup>#1</sup>	100 mA, 5 V DC		

#1 This value can change due to the switching frequency, environmental conditions, and desired reliability level, therefore it is recommended to check this with the actual load.

### Remarks

- \* Specifications will vary with foreign standards certification ratings.
- \*1 Measurement at same location as "initial breakdown voltage" section
- \*2 Detection current; 10 mA
- \*3 Excluding contact bounce time
- \*4 Half-wave pulse of sine wave: 11ms; detection time: 10μs
- \*5 Half-wave pulse of sine wave: 6ms
- \*6 Detection time: 10μs
- \*7 Refer to 6. Conditions for operation, transport and storage mentioned in AMBIENT ENVIRONMENT.

### Characteristics (at 60 Hz, 20°C 68°F)

		2 Form C	3 Form C	4 Form C
Maximum operating speed		20 cpm		
Initial insulation resistance*1		more than 100 MΩ at 500 V DC		
Breakdown voltage*2	Between open contacts	1,000 Vrms	2,000 Vrms	1,000 Vrms
	Between contact sets	1,500 Vrms	2,000 Vrms	1,500 Vrms
	Between contact and coil	1,500 Vrms	2,000 Vrms	1,500 Vrms
Operate time*3 (at nominal voltage)		Max. 25 ms	Max. 30 ms	
Release time (without diode)*3 (at nominal voltage)		Max. 25 ms	Max. 30 ms	
Temperature rise		Max. 65°C		
Shock resistance	Functional*4	98 m/s <sup>2</sup> {10 G}		
	Destructive*5	980 m/s <sup>2</sup> {100 G}		
Vibration resistance	Functional*6	10 to 55 Hz at 1 mm double amplitude		
	Destructive	10 to 55 Hz at 2 mm double amplitude		
Conditions for operation, transport and storage*7 (Not freezing and condensing at low temperature)	Ambient temp.	-50°C to +40°C -58°F to +104°F		
	Humidity	5 to 85% R.H.		
Unit weight		Approx. 60g 2.12 oz	Approx. 100g 3.53 oz	Approx. 125g 4.41 oz

## LIFE DATA

### Contact rating and expected life For AC load type

	Voltage	125 V AC		250 V AC		Expected life (min. operations)
		Resistive ( $\cos \varphi \approx 1$ )	Inductive ( $\cos \varphi \approx 0.4$ )	Resistive ( $\cos \varphi \approx 1$ )	Inductive ( $\cos \varphi \approx 0.4$ )	
Electrical life	Current	—	—	10 A	7.5 A	$2 \times 10^5$
		10 A	7.5 A	7.5 A	5 A	$5 \times 10^5$
		5 A	3 A	3 A	2 A	$1 \times 10^6$
		1A	0.7 A	0.6 A	0.4 A	$2 \times 10^6$
Mechanical life						$1 \times 10^7$

Note: When the electromagnet or exciting coil (Solenoid, etc.) is the load, the value of motor or lamp load is applicable.

### Contact rating and expected life For DC load type

	Voltage	24 V DC		125 V DC		Expected life (min. operations)
		Resistive ( $\cos \varphi \approx 1$ )	Inductive ( $\cos \varphi \approx 0.4$ )	Resistive ( $\cos \varphi \approx 1$ )	Inductive ( $\cos \varphi \approx 0.4$ )	
Electrical life	Current	—	7 A	—	—	$2 \times 10^5$
		7.5 A	5 A	0.5 A	0.4 A	$5 \times 10^5$
		5 A	3 A	0.3 A	0.2 A	$1 \times 10^6$
		1A	0.6 A	0.1 A	0.06 A	$2 \times 10^6$
Mechanical life						$1 \times 10^7$

### Life curve

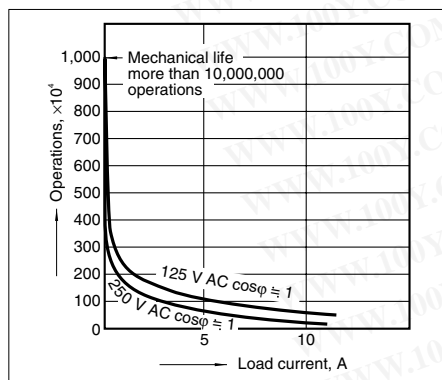

### Notes:

- For DC inductive loads, use an arc suppressing circuit.
- When used under a DC load operating at high repetition rate with considerable arcing, corrosion of the contacts and/or the contact blades is likely to occur. When using the relay under conditions of high temperature, humidity or high repetition rate, it is suggested that the relay cover be removed to facilitate extended operation.

勝特力材料 886-3-5753170  
 勝特力电子(上海) 86-21-54151736  
 勝特力电子(深圳) 86-755-83298787  
[Http://www.100y.com.tw](http://www.100y.com.tw)

## TYPICAL APPLICATIONS

HP relays enjoy wide use in various applications, particularly in automation controls and remote controls.  
 Applications include:  
 Industrial machinery

Machine tool  
 Food processing packing machines  
 Office equipment  
 Coin operate devices  
 Home appliances

Transportation  
 Communication and measuring devices  
 Amusement devices

## ORDERING INFORMATION

Ex. HP 3 — M — AC240V — F

Contact arrangement	Terminal	Coil voltage	Contact material
2: 2 Form C 3: 3 Form C 4: 4 Form C	Nil: Standard plug-in terminal M: Direct mounting (3 Form C only) TM: Top mounting (2 Form C only) L: Lamp wired, standard plug-in terminal	AC 6, 12, 24, 48, 115, 220, 240 V DC 6, 12, 24, 48, 110 V	F: 4 Form C Silver alloy (cadmium free) Nil: 2 Form C, 3 Form C (Silver)

- (Notes) 1. Standard packing Carton: 50 pcs. Case: 200 pcs.  
 2. UL/CSA approved type is standard.

## TYPES AND COIL DATA

勝特力材料 886-3-5753170  
 勝特力电子(上海) 86-21-54151736  
 勝特力电子(深圳) 86-755-83298787  
[Http://www.100y.com.tw](http://www.100y.com.tw)

## 1. Standard plug-in terminal type (without lamp wired)

DC TYPES at 20°C 68°F

Type	Part No.	Nominal coil voltage, V DC	Pick-up voltage, V DC (max.)	Drop-out voltage, V DC (min.)	Max. allowable voltage, V DC	Coil resistance, $\Omega$ ( $\pm 10\%$ )	Nominal coil current, mA	Nominal operating power, W
2 Form C	HP2-DC6V	6	4.8	0.9	6.6	25	240	1.5
	HP2-DC12V	12	9.6	1.8	13.2	110	109	1.3
	HP2-DC24V	24	19.2	3.6	26.4	440	54.5	1.3
	HP2-DC48V	48	38.4	7.2	52.8	1,800	26.7	1.3
	HP2-DC110V	110	88	16.5	121	7,300	15.0	1.7
3 Form C	HP3-DC6V	6	4.8	0.9	6.6	24	250	1.5
	HP3-DC12V	12	9.6	1.8	13.2	100	120	1.4
	HP3-DC24V	24	19.2	3.6	26.4	400	60	1.4
	HP3-DC48V	48	38.4	7.2	52.8	1,560	31	1.5
	HP3-DC110V	110	88	16.5	121	7,450	14.9	1.6
4 Form C	HP4-DC6V-F	6	4.8	0.9	6.6	22	273	1.6
	HP4-DC12V-F	12	9.6	1.8	13.2	95	127	1.5
	HP4-DC24V-F	24	19.2	3.6	26.4	380	63	1.5
	HP4-DC48V-F	48	38.4	7.2	52.8	1,500	32	1.5
	HP4-DC110V-F	110	88	16.5	121	7,000	15.7	1.7

AC TYPE (50/60 Hz) at 60 Hz, 20°C 68°F

Type	Part No.	Nominal coil voltage, V AC	Pick-up voltage, V AC (max.)	Drop-out voltage, V AC (min.)	Max. allowable voltage, V AC	Inductance, H	Nominal coil current, mA	Nominal operating power, VA
2 Form C	HP2-AC6V	6	4.8	1.8	6.6	0.049	310	1.9
	HP2-AC12V	12	9.6	3.6	13.2	0.190	160	1.9
	HP2-AC24V	24	19.2	7.2	26.4	0.776	78	1.9
	HP2-AC48V	48	38.4	14.4	52.8	3.106	39	1.9
	HP2-AC115V	115	92	34.5	126.5	15.83	18	2.1
	HP2-AC220V	220	176	66	242	57.90	9.5	2.1
	HP2-AC240V	240	192	72	264	66.26	9.0	2.2
3 Form C	HP3-AC6V	6	4.8	1.8	6.6	0.030	520	3.1
	HP3-AC12V	12	9.6	3.6	13.2	0.119	260	3.1
	HP3-AC24V	24	19.2	7.2	26.4	0.475	130	3.1
	HP3-AC48V	48	38.4	14.4	52.8	1.899	65	3.1
	HP3-AC115V	115	92	34.5	126.5	10.36	28.5	3.3
	HP3-AC220V	220	176	66	242	39.32	14.2	3.1
	HP3-AC240V	240	192	72	264	44.05	13.9	3.3
4 Form C	HP4-AC6V-F	6	4.8	1.8	6.6	0.019	800	4.8
	HP4-AC12V-F	12	9.6	3.6	13.2	0.077	400	4.8
	HP4-AC24V-F	24	19.2	7.2	26.4	0.309	200	4.8
	HP4-AC48V-F	48	38.4	14.4	52.8	1.292	95	4.6
	HP4-AC115V-F	115	92	34.5	126.5	6.953	42	4.8
	HP4-AC220V-F	220	176	66	242	26.57	21	4.6
	HP4-AC240V-F	240	192	72	264	29.75	20.5	4.9

## NOTES

- The range of coil current for AC relays is  $\pm 15\%$  (60 Hz). For DC relays it is  $\pm 10\%$  at 20°C, 68°F.
- The HP relay will operate in a range from 80% to 110% of the nominal coil voltage. It is, however, recommended that the relay be used in the range of 85% to 110% of the nominal coil voltage, with the temporary voltage variation taken into consideration.
- When the operating voltage of AC relays drops below 80% of the nominal coil voltage, the relay will generate a considerable amount of heat which is not recommended for maximum efficiency.
- The coil resistance of DC types is the measured value of the coil at a temperature of 20°C 68°F. If the coil temperature changes by  $\pm 1^\circ\text{C}$ , the measured value of the coil resistance should be increased or decreased by 0.4%.
- For applications from 220 V to 240 V DC, connect a resistor in series with the relay coil. See chart for resistor values.

Voltage	2 Form C	3 Form C	4 Form C
220 V DC	7.3 k $\Omega$ (5 W)	7.45 k $\Omega$ (5 W)	7 k $\Omega$ (5 W)
240 V DC	8.7 k $\Omega$ (5 W)	8.8 k $\Omega$ (5 W)	8.3 k $\Omega$ (5 W)



**2. Standard plug-in terminal type (with lamp wired)**

DC TYPES at 20°C 68°F

Type	Part No.	Nominal coil voltage, V DC	Pick-up voltage, V DC (max.)	Drop-out voltage, V DC (min.)	Max. allowable voltage, V DC	Coil resistance, $\Omega$ ( $\pm 10\%$ )	Nominal coil current, mA	Nominal operating power, W	
2 Form C	LED	HP2-L-DC6V	6	4.8	0.9	6.6	25	240	1.5
		HP2-L-DC12V	12	9.6	1.8	13.2	110	109	1.3
		HP2-L-DC24V	24	19.2	3.6	26.4	440	54.5	1.3
		HP2-L-DC48V	48	38.4	7.2	52.8	1,800	26.7	1.3
	Neon lamp	HP2-L-DC110V	110	88	16.5	121	7,300	15.0	1.7
3 Form C	LED	HP3-L-DC6V	6	4.8	0.9	6.6	24	250	1.5
		HP3-L-DC12V	12	9.6	1.8	13.2	100	120	1.4
		HP3-L-DC24V	24	19.2	3.6	26.4	400	60	1.4
		HP3-L-DC48V	48	38.4	7.2	52.8	1,560	31	1.5
	Neon lamp	HP3-L-DC110V	110	88	16.5	121	7,450	14.9	1.6
4 Form C	LED	HP4-L-DC6V-F	6	4.8	0.9	6.6	22	273	1.6
		HP4-L-DC12V-F	12	9.6	1.8	13.2	95	127	1.5
		HP4-L-DC24V-F	24	19.2	3.6	26.4	380	63	1.5
		HP4-L-DC48V-F	48	38.4	7.2	52.8	1,500	32	1.5
	Neon lamp	HP4-L-DC110V-F	110	88	16.5	121	7,000	15.7	1.7

AC TYPE (50/60 Hz) at 60 Hz, 20°C 68°F

Type	Part No.	Nominal coil voltage, V AC	Pick-up voltage, V AC (max.)	Drop-out voltage, V AC (min.)	Max. allowable voltage, V AC	Inductance, H	Nominal coil current, mA	Nominal operating power, VA	
2 Form C	LED	HP2-L-AC6V	6	4.8	1.8	6.6	0.049	310	1.9
		HP2-L-AC12V	12	9.6	3.6	13.2	0.190	160	1.9
		HP2-L-AC24V	24	19.2	7.2	26.4	0.776	78	1.9
	Neon lamp	HP2-L-AC115V	115	92	34.5	126.5	15.83	18	2.1
		HP2-L-AC220V	220	176	66	242	57.90	9.5	2.1
		HP2-L-AC240V	240	192	72	264	66.26	9.0	2.2
3 Form C	LED	HP3-L-AC6V	6	4.8	1.8	6.6	0.030	520	3.1
		HP3-L-AC12V	12	9.6	3.6	13.2	0.119	260	3.1
		HP3-L-AC24V	24	19.2	7.2	26.4	0.475	130	3.1
	Neon lamp	HP3-L-AC115V	115	92	34.5	126.5	10.36	28.5	3.3
		HP3-L-AC220V	220	176	66	242	39.32	14.2	3.1
		HP3-L-AC240V	240	192	72	264	44.05	13.9	3.3
4 Form C	LED	HP4-L-AC6V-F	6	4.8	1.8	6.6	0.019	800	4.8
		HP4-L-AC12V-F	12	9.6	3.6	13.2	0.077	400	4.8
		HP4-L-AC24V-F	24	19.2	7.2	26.4	0.309	200	4.8
	Neon lamp	HP4-L-AC115V-F	115	92	34.5	126.5	6.953	42	4.8
		HP4-L-AC220V-F	220	176	66	242	26.57	21	4.6
		HP4-L-AC240V-F	240	192	72	264	29.75	20.5	4.9

勝特力材料 886-3-5753170  
 勝特力电子(上海) 86-21-54151736  
 勝特力电子(深圳) 86-755-83298787  
[Http://www.100y.com.tw](http://www.100y.com.tw)

### 3. Top Mounting (TM) and direct mounting (M) type

DC TYPES at 20°C 68°F

Type	Part No.	Nominal coil voltage, V DC	Pick-up voltage, V DC (max.)	Drop-out voltage, V DC (min.)	Max. allowable voltage, V DC	Coil resistance, Ω (±10%)	Nominal coil current, mA	Nominal operating power, W
2 Form C Top Mounting Type (TM)	HP2-TM-DC6V	6	4.8	0.9	6.6	25	240	1.5
	HP2-TM-DC12V	12	9.6	1.8	13.2	110	109	1.3
	HP2-TM-DC24V	24	19.2	3.6	26.4	440	54.5	1.3
	HP2-TM-DC48V	48	38.4	7.2	52.8	1,800	26.7	1.3
	HP2-TM-DC110V	110	88	16.5	121	7,300	15.0	1.7
3 Form C Direct Mounting Type (TM)	HP3-M-DC6V	6	4.8	0.9	6.6	24	250	1.5
	HP3-M-DC12V	12	9.6	1.8	13.2	100	120	1.4
	HP3-M-DC24V	24	19.2	3.6	26.4	400	60	1.4
	HP3-M-DC48V	48	38.4	7.2	52.8	1\$B!(J560	31	1.5
	HP3-M-DC110V	110	88	16.5	121	7,450	14.9	1.6

AC TYPE (50/60 Hz) at 60 Hz, 20°C 68°F

Type	Part No.	Nominal coil voltage, V AC	Pick-up voltage, V AC (max.)	Drop-out voltage, V AC (min.)	Max. allowable voltage, V AC	Inductance, H	Nominal coil current, mA	Nominal operating power, VA
2 Form C Top Mounting Type (TM)	HP2-TM-AC6V	6	4.8	1.8	6.6	0.049	310	1.9
	HP2-TM-AC12V	12	9.6	3.6	13.2	0.190	160	1.9
	HP2-TM-AC24V	24	19.2	7.2	26.4	0.776	78	1.9
	HP2-TM-AC48V	48	38.4	14.4	52.8	3.106	39	1.9
	HP2-TM-AC115V	115	92	34.5	126.5	15.83	18	2.1
	HP2-TM-AC220V	220	176	66	242	57.90	9.5	2.1
	HP2-TM-AC240V	240	192	72	264	66.26	9.0	2.2
3 Form C Direct Mounting Type (M)	HP3-M-AC6V	6	4.8	1.8	6.6	0.030	520	3.1
	HP3-M-AC12V	12	9.6	3.6	13.2	0.119	260	3.1
	HP3-M-AC24V	24	19.2	7.2	26.4	0.475	130	3.1
	HP3-M-AC48V	48	38.4	14.4	52.8	1.899	65	3.1
	HP3-M-AC115V	115	92	34.5	126.5	10.36	28.5	3.3
	HP3-M-AC220V	220	176	66	242	39.32	14.2	3.1
	HP3-M-AC240V	240	192	72	264	44.05	13.9	3.3

### 4. Direct mounting (with lamp wired) type

DC TYPES

Type	Part No.	Nominal coil voltage, V DC	Pick-up voltage, V DC (max.)	Drop-out voltage, V DC (min.)	Max. allowable voltage, V DC	Coil resistance, Ω (±10%)	Nominal coil current, mA	Nominal operating power, W
3 Form C Neon lamp	HP3-ML-DC110V	110	88	16.5	121	7,450	14.9	1.6

AC TYPE (50/60 Hz) at 60 Hz, 20°C 68°F

Type	Part No.	Nominal coil voltage, V AC	Pick-up voltage, V AC (max.)	Drop-out voltage, V AC (min.)	Max. allowable voltage, V AC	Inductance, H	Nominal coil current, mA	Nominal operating power, VA
3 Form C Neon lamp	HP3-ML-AC115V	115 V	92	34.5	126.5	10.36	28.5	3.3
	HP3-ML-AC220V	220 V	176	66	242	39.32	14.2	3.1
	HP3-ML-AC240V	240 V	192	72	264	44.05	13.9	3.3

勝特力材料 886-3-5753170  
 勝特力电子(上海) 86-21-54151736  
 勝特力电子(深圳) 86-755-83298787  
[Http://www.100y.com.tw](http://www.100y.com.tw)

# LAMP-WIRED RELAYS

## Specifications

Life of neon lamp....continuous: more than 25,000 hours  
(more than 3 years)  
on/off = 1: more than 6 years  
Life of LED .....continuous: more than 50,000 hours  
(more than 5.5 years)  
on/off = 1: more than 100,000 hours  
(more than 11 years)

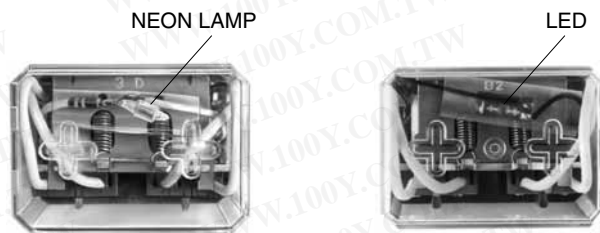

## Variation

Type	Coil Voltage		
	AC	DC	
HP2-L HP3-L HP3-ML HP4-L	6 V	6 V	LED (Light emitting diode)
	12 V	12 V	
	24 V	24 V	
	—	48 V	Neon lamp
	115 V	110 V	
	220 V	—	
	240 V	—	

Notes:

1. AC 48 V type is not available for lamp wiring.

## Circuit diagrams

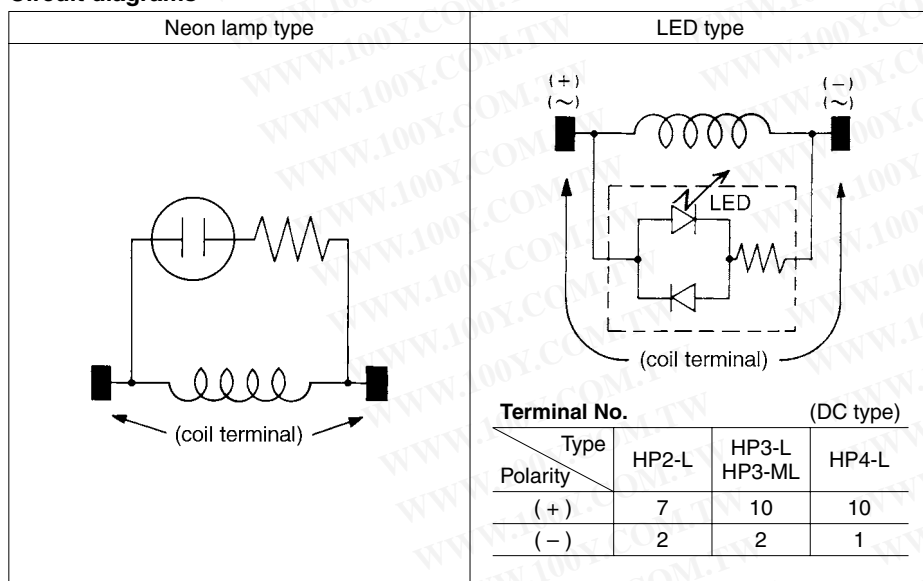

Notes:

1. Pay attention to the polarity of coil See circuit diagram (LED type only).

## Operating current of LED

Coil Voltage	Operating current of LED
DC 6V	DC 6.4 mA
DC 12V	DC 5.7 mA
DC 24V	DC 4.7 mA
DC 48V	DC 4.5 mA
AC 6V	AC 10.5 mA
AC 12V	AC 9.0 mA
AC 24V	AC 7.7 mA









Notes:

- Operating current of relays should be increased by the value of LED operating current. Please refer the table. Operating current of neon lamp is approx. 0.3 mA to 0.4 mA.
- To use the HP relay in the inductive load circuit, the contact protection circuit is recommended.

**勝特力材料 886-3-5753170**  
**胜特力电子(上海) 86-21-54151736**  
**胜特力电子(深圳) 86-755-83298787**  
[Http://www.100y.com.tw](http://www.100y.com.tw)

## ACCESSORIES

Please refer to "MOUNTING METHODS" for further information.  
UL, CSA recognized except BRACKET and INSERTING PLATE.

HP	Relay	Solder terminal socket for rectangular hold boring (with hold-down clip)	Screw terminal socket for DIN rail assembly (with hold-down clip)
HP2		HP2-SRS  (UL, CSA, VDE)	HP2-SFD  (UL, CSA)
HP3		HP3-SRS  (UL, CSA, VDE)	HP3-SFD  (UL, CSA)
HP4		HP4-SRS  (UL, CSA)	HP4-SFD  (UL, CSA)

## DIMENSIONS AND WIRING DIAGRAM

mm inch

HP2 (2 Form C) Plug-in terminal types

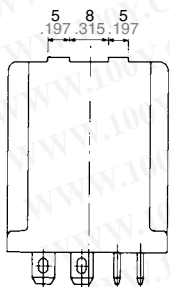
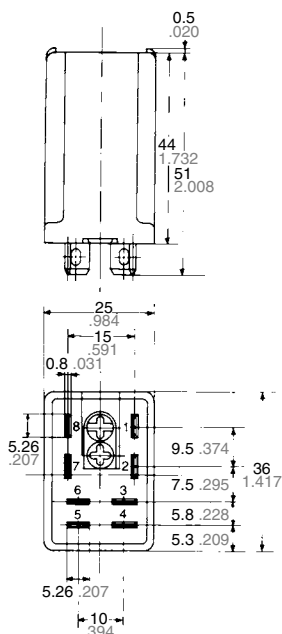

Circuit diagram

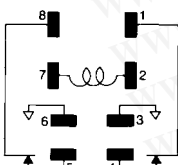

勝特力材料 886-3-5753170  
 勝特力电子(上海) 86-21-54151736  
 勝特力电子(深圳) 86-755-83298787  
[Http://www.100y.com.tw](http://www.100y.com.tw)

Dimension :	General tolerance
Max. 2mm .079 inch:	±0.2 ±.008
2 to 9mm .079 to .354 inch:	±0.5 ±.020
9 to 20mm .354 to .787 inch:	±1.0 ±.039
Min. 20mm .787 inch:	±1.5 ±.059

Accepts  
Faston 205



**HP2-SRS (with hold-down clip)**

Optimum space-saving panel cut-out.  
 Can be mounted from either the front or the rear of the panel.

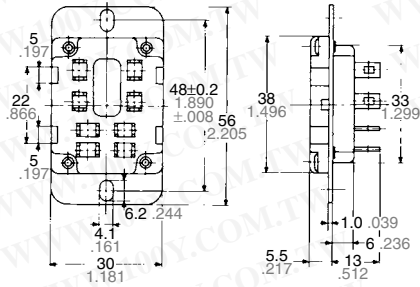

Dimension :	General tolerance
Max. 2mm .079 inch:	±0.2 ±.008
2 to 9mm .079 to .354 inch:	±0.5 ±.020
9 to 20mm .354 to .787 inch:	±1.0 ±.039
Min. 20mm .787 inch:	±1.5 ±.059

Front surface-mounting

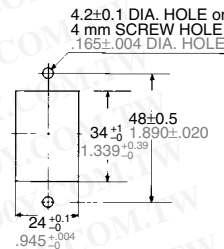

Rear surface-mounting

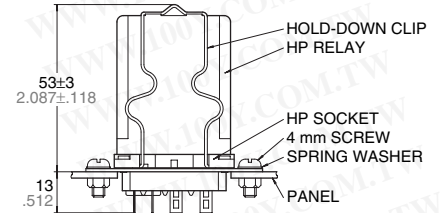
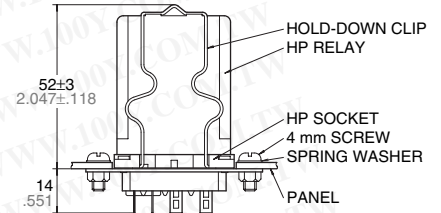
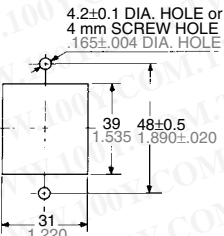

**HP2-SFD (with hold-down clip)**

Front wiring in restricted space

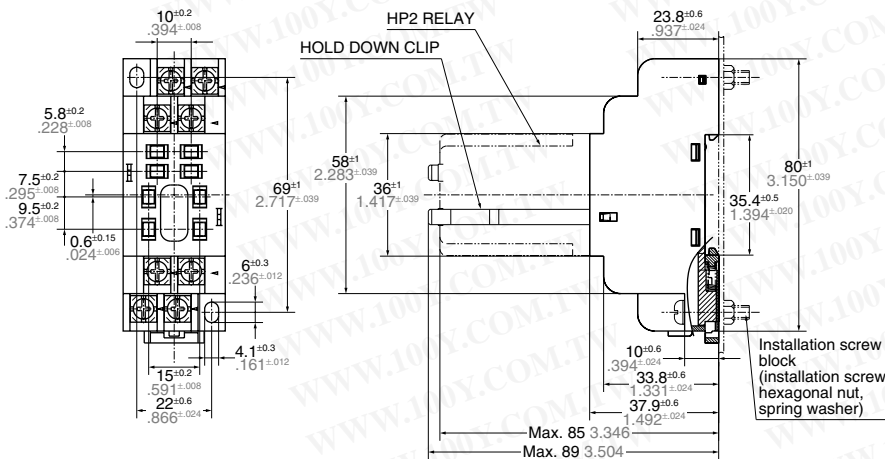

Dimension :	General tolerance
Max. 2mm .079 inch:	±0.2 ±.008
2 to 9mm .079 to .354 inch:	±0.5 ±.020
9 to 20mm .354 to .787 inch:	±1.0 ±.039
Min. 20mm .787 inch:	±1.5 ±.059

Mounting dimensions

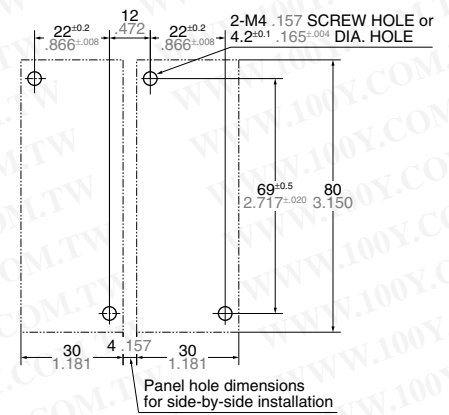

Note: Hold down clip and installation screw block are included in package.

**HP2-TM (2 Form C) Top mounting types**

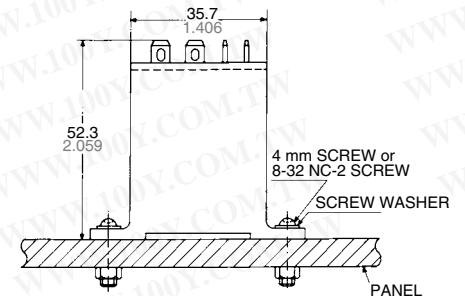
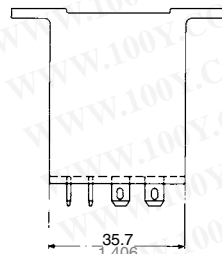
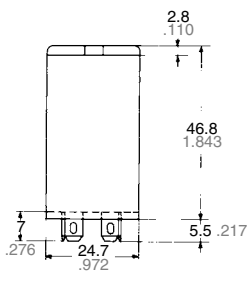

Mounting dimensions

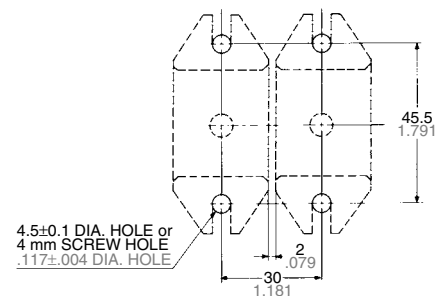

Circuit diagram

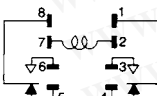

Dimension :	General tolerance
Max. 2mm .079 inch:	±0.2 ±.008
2 to 9mm .079 to .354 inch:	±0.5 ±.020
9 to 20mm .354 to .787 inch:	±1.0 ±.039
Min. 20mm .787 inch:	±1.5 ±.059

Accepts  
 Faston 205



## HP3 (3 Form C) Plug-in terminal types

mm inch

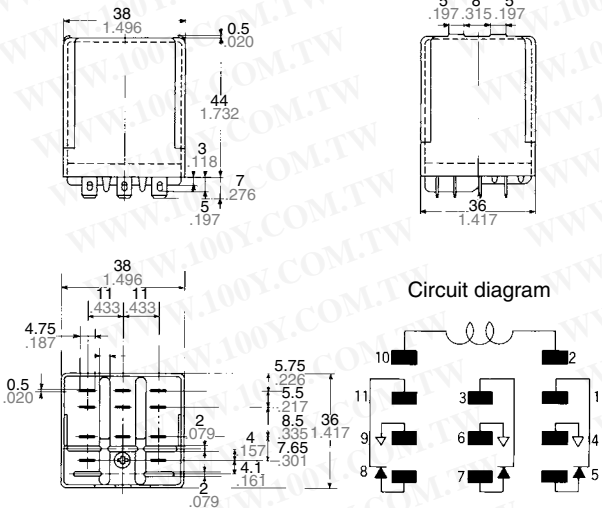

**勝特力材料 886-3-5753170**  
**勝特力电子(上海) 86-21-54151736**  
**勝特力电子(深圳) 86-755-83298787**  
[Http://www.100y.com.tw](http://www.100y.com.tw)

Accepts  
Faston 187

Dimension :	General tolerance
Max. 2mm .079 inch:	$\pm 0.2 \pm .008$
2 to 9mm .079 to .354 inch:	$\pm 0.5 \pm .020$
9 to 20mm .354 to .787 inch:	$\pm 1.0 \pm .039$
Min. 20mm .787 inch:	$\pm 1.5 \pm .059$

## HP3-SRS (with hold-down clip)

Optimum space-saving panel cut-out.  
Can be mounted from either the front or the rear of the panel.

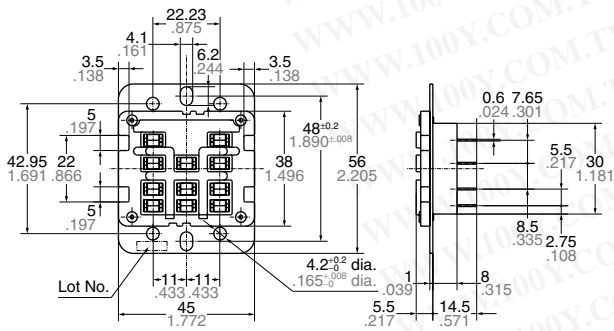

Dimension :	General tolerance
Max. 2mm .079 inch:	$\pm 0.2 \pm .008$
2 to 9mm .079 to .354 inch:	$\pm 0.5 \pm .020$
9 to 20mm .354 to .787 inch:	$\pm 1.0 \pm .039$
Min. 20mm .787 inch:	$\pm 1.5 \pm .059$

### Front surface-mounting

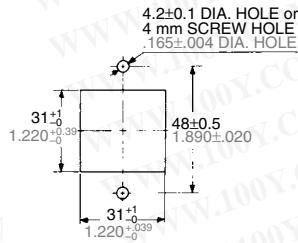

### Rear surface-mounting

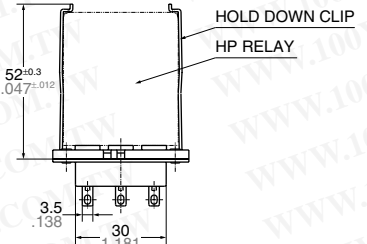
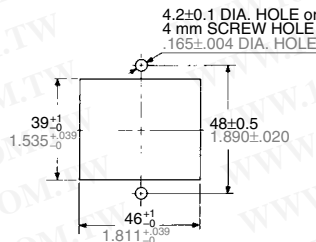

## HP3-SFD (with hold-down clip)

Front wiring in restricted space

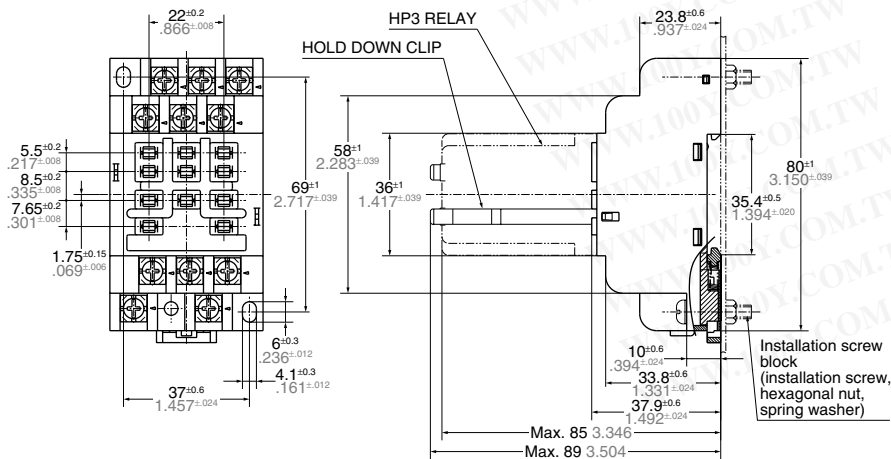

### Mounting dimensions

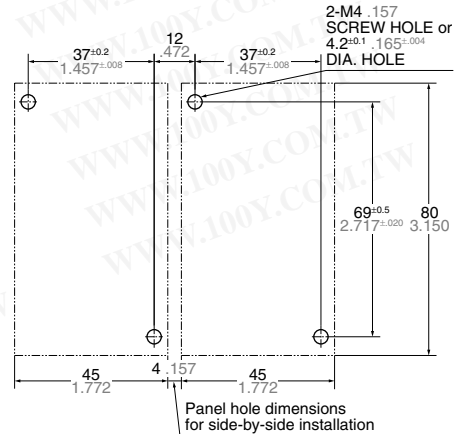

Dimension :	General tolerance
Max. 2mm .079 inch:	$\pm 0.2 \pm .008$
2 to 9mm .079 to .354 inch:	$\pm 0.5 \pm .020$
9 to 20mm .354 to .787 inch:	$\pm 1.0 \pm .039$
Min. 20mm .787 inch:	$\pm 1.5 \pm .059$

Note: Hold down clip and installation screw block are included in package.

HP3-M (3 Form C) Direct mounting types

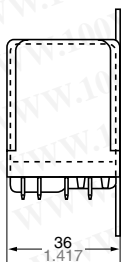
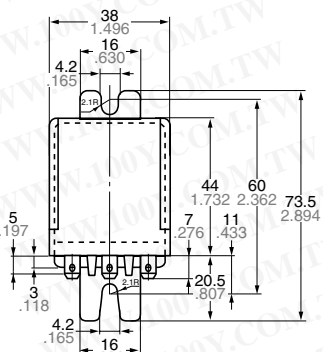

Mounting dimension

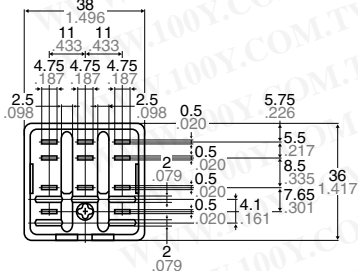
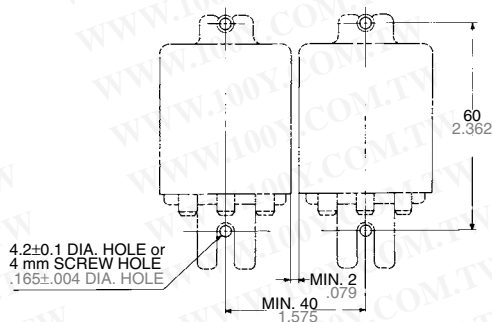

Circuit diagram

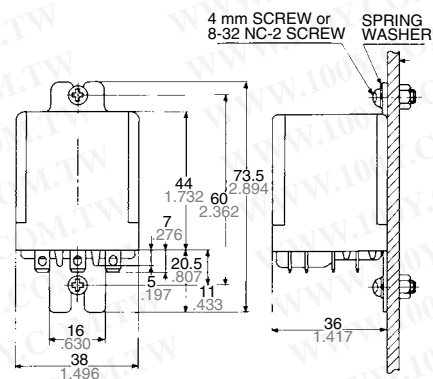
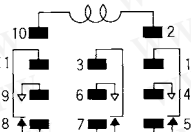

Accepts  
Faston 187

Dimension :	General tolerance
Max. 2mm .079 inch:	$\pm 0.2 \pm 0.08$
2 to 9mm .079 to .354 inch:	$\pm 0.5 \pm 0.20$
9 to 20mm .354 to .787 inch:	$\pm 1.0 \pm 0.39$
Min. 20mm .787 inch:	$\pm 1.5 \pm 0.59$

HP4 (4 Form C) Plug-in terminal types

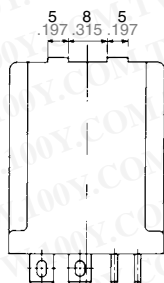
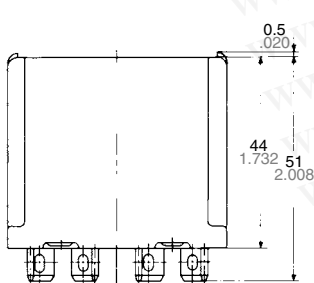

勝特力材料 886-3-5753170  
 勝特力电子(上海) 86-21-54151736  
 勝特力电子(深圳) 86-755-83298787  
[Http://www.100y.com.tw](http://www.100y.com.tw)

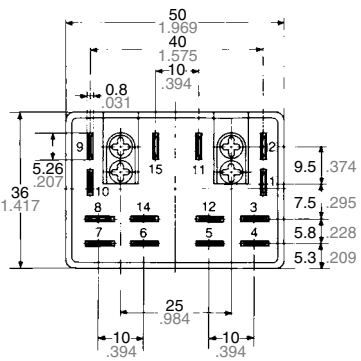

Circuit diagram

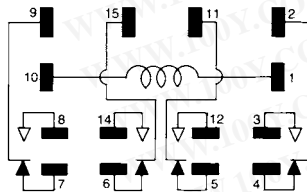

Accepts  
Faston 187

Dimension :	General tolerance
Max. 2mm .079 inch:	$\pm 0.2 \pm 0.08$
2 to 9mm .079 to .354 inch:	$\pm 0.5 \pm 0.20$
9 to 20mm .354 to .787 inch:	$\pm 1.0 \pm 0.39$
Min. 20mm .787 inch:	$\pm 1.5 \pm 0.59$

# HP

## HP4-SRS (with hold-down clip)

mm inch

Optimum space-saving panel cut-out.  
Can be mounted from either the front or the rear of the panel.

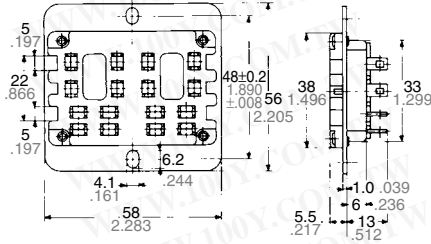

### Front surface-mounting

4.2±0.1 DIA. HOLE or  
4 mm SCREW HOLE  
1.65±.004 DIA. HOLE

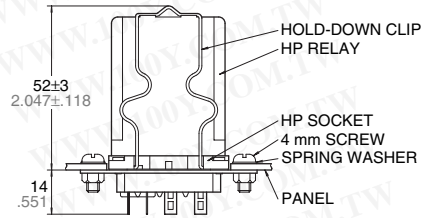
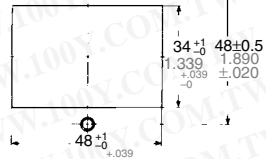

### Rear surface-mounting

4.2±0.1 DIA. HOLE or  
4 mm SCREW HOLE  
1.65±.004 DIA. HOLE

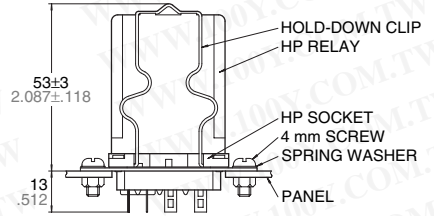
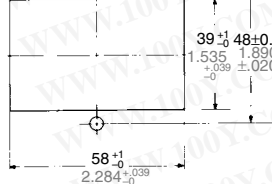

Dimension :	General tolerance
Max. 2mm .079 inch:	±0.2 ±.008
2 to 9mm .079 to .354 inch:	±0.5 ±.020
9 to 20mm .354 to .787 inch:	±1.0 ±.039
Min. 20mm .787 inch:	±1.5 ±.059

## HP4-SFD (with hold-down clip)

Front wiring in restricted space.  
Two HP2 relays can be mounted in one socket.

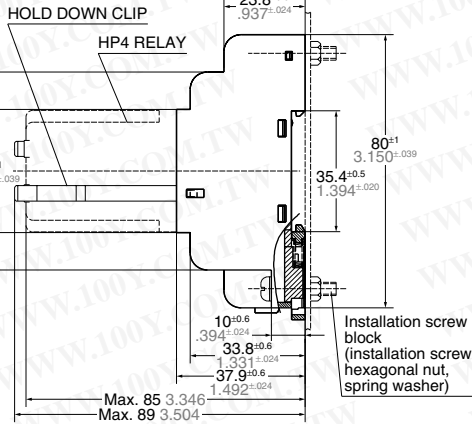
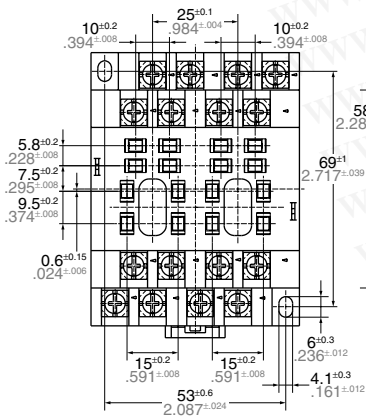

### Mounting dimensions

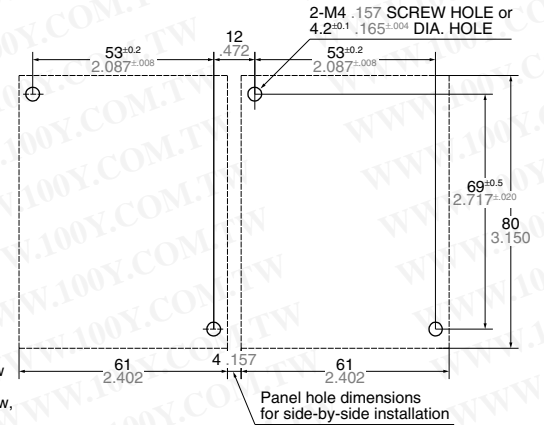

Note: Hold down clip and installation screw block are included in package.

Dimension :	General tolerance
Max. 2mm .079 inch:	±0.2 ±.008
2 to 9mm .079 to .354 inch:	±0.5 ±.020
9 to 20mm .354 to .787 inch:	±1.0 ±.039
Min. 20mm .787 inch:	±1.5 ±.059

**For Cautions for Use, see Relay Technical Information.**

勝特力材料 886-3-5753170  
 勝特力电子(上海) 86-21-54151736  
 勝特力电子(深圳) 86-755-83298787  
[Http://www.100y.com.tw](http://www.100y.com.tw)