

# Panasonic

ideas for life

## SLIM POWER RELAY WITH HIGH INRUSH CURRENT CAPABILITY

## LK RELAYS

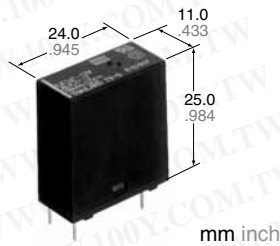

RoHS Directive compatibility information  
<http://www.nais-e.com/>

### FEATURES

- 1. High inrush current capability**  
 1) Operating load capability:  
 inrush 100 A, steady 5 A  
 2) UL/CSA, TV-5

- 2. High insulation resistance between contact and coil**  
 1) Creepage distance and clearances between contact and coil: Min. 6 mm .236 inch (In compliance with IEC65)  
 2) Surge withstand voltage between contact and coil: 10,000 V or more
- 3. High noise immunity realized by the card separation structure between contact and coil**
- 4. Popular terminal pitch in AV equipment field**

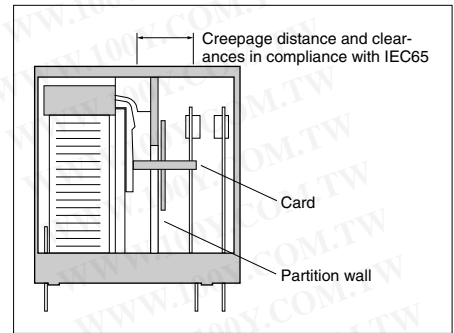

- 5. Space-saving slim type**  
 Base area: Width 11 × Length 24 mm  
 Width .433 × Length .945 inch

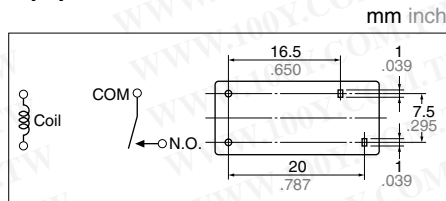

- 6. Conforms to the various safety standards**  
 UL, CSA, VDE, TÜV, SEMKO, SEV, BSI approved

### SPECIFICATIONS

#### Contact

Arrangement	1 Form A	
Initial contact resistance, max. (By voltage drop 6 V DC 1 A)	Max. 100 mΩ	
Contact material	AgSnO <sub>2</sub> type	
Rating (resistive load)	Nominal switching capacity	5 A 277 V AC, 5 A 30 V DC
	Max. switching power	1,385 VA, 150 W
	Max. switching voltage	277 V AC, 30 V DC
	Max. switching current	5A (AC), 5 A (DC)
Expected life (min. ope.)	Mechanical (at 180 cpm)	2 × 10 <sup>6</sup>
	Electrical (at 20 cpm) (at rated load)	10 <sup>5</sup>

#### Coil

Nominal operating power	530 mW
-------------------------	--------

#1 This value can change due to the switching frequency, environmental conditions, and desired reliability level, therefore it is recommended to check this with the actual load.

#### Remarks

- \* Specifications will vary with foreign standards certification ratings.
- \*1 Measurement at same location as "Initial breakdown voltage" section.
- \*2 Detection current: 10mA
- \*3 Wave is standard shock voltage of  $\pm 1.2 \times 50\mu s$  according to JEC-212-1981
- \*4 Excluding contact bounce time.
- \*5 Half-wave pulse of sine wave: 11 ms; detection time: 10  $\mu s$
- \*6 Half-wave pulse of sine wave: 6 ms
- \*7 Detection time: 10  $\mu s$
- \*8 Refer to 6. Conditions for operation, transport and storage mentioned in AMBIENT ENVIRONMENT .

#### Characteristics

Max. operating speed	20 cpm	
Initial insulation resistance*1	Min. 1,000 MΩ (at 500 V DC)	
Initial breakdown voltage*2	Between open contacts	1,000 Vrms for 1 min
	Between contacts and coil	4,000 Vrms for 1 min
Initial surge voltage between contact and coil*3	Min. 10,000 V	
Operate time*4 (at nominal voltage)	Max. 15 ms (at 20°C 68°F)	
Release time (without diode)*4 (at nominal voltage)	Max. 5 ms (at 20°C 68°F)	
Temperature rise (at 70°C)	Max. 35°C with nominal coil voltage at 5A contact carrying current (resistance method)	
Shock resistance	Functional*5	Min. 200 m/s <sup>2</sup>
	Destructive*6	Min. 1,000 m/s <sup>2</sup>
Vibration resistance	Functional*7	10 to 55 Hz at double amplitude of 1.5 mm
	Destructive	10 to 55 Hz at double amplitude of 1.5 mm
Conditions for operation, transport and storage*8 (Not freezing and condensing at low temperature)	Ambient temp.	-40 to +70°C -40 to +158°F
	Humidity	5 to 85%R.H.
	Air pressure	86 to 106 kPa
Unit weight	Approx. 12 g .42 oz	

### TYPICAL APPLICATIONS

- AV equipment: TV's, VTR's, etc.
- OA equipment
- HA equipment

### ORDERING INFORMATION

Ex. LK 1a F — 24V

Contact arrangement	Protective construction	Coil voltage (DC)
1a: 1 Form A	F: Flux-resistant type	5, 6, 9, 12, 18, 24 V

UL/CSA, TÜV, SEMKO, TV-5 approved type is standard.  
 (Note) Standard packing Carton: 100 pcs. Case: 500 pcs.

勝特力材料 886-3-5753170  
 勝特力电子(上海) 86-21-54151736  
 勝特力电子(深圳) 86-755-83298787  
[Http://www.100y.com.tw](http://www.100y.com.tw)

LK

勝特力材料 886-3-5753170  
 勝特力电子(上海) 86-21-54151736  
 勝特力电子(深圳) 86-755-83298787  
 Http://www.100y.com.tw

**TYPES AND COIL DATA (at 20°C 68°F)**

Part No.	Nominal voltage, V DC	Pick-up voltage V DC (max.) (Initial)	Drop-out voltage V DC (min.) (Initial)	Coil resistance, Ω (±10%)	Nominal operating current, mA (±10%)	Nominal operating power, mW	Max. allowable voltage, V DC (at 20°C 68°F)
LK1aF-5V	5	3.5	0.5	47	106.4	530	6.5
LK1aF-6V	6	4.2	0.6	68	88.3	530	7.8
LK1aF-9V	9	6.3	0.9	153	58.8	530	11.7
LK1aF-12V	12	8.4	1.2	272	44.2	530	15.6
LK1aF-18V	18	12.6	1.8	611	29.5	530	23.4
LK1aF-24V	24	16.8	2.4	1,087	22.1	530	31.2

**DIMENSIONS**

mm inch

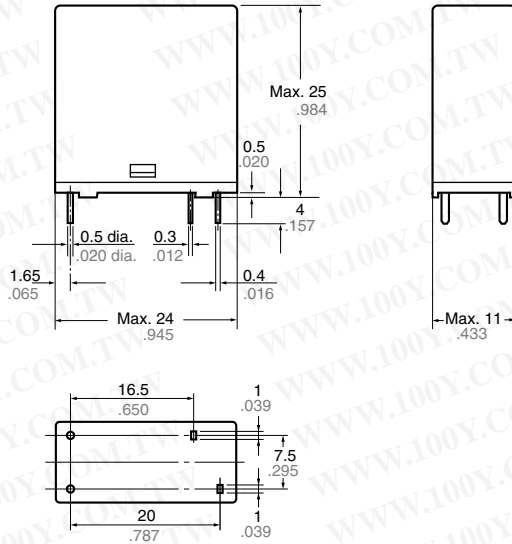

PC board pattern (Bottom view)

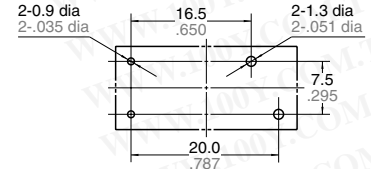

Tolerance: ±0.1 ±.004

Schematic (Bottom view)



Dimension :  
 Max. 1mm .039 inch: ±0.1 ±.004  
 1 to 3mm .039 to .118 inch: ±0.2 ±.008  
 Min. 3mm .118 inch: ±0.3 ±.012

General tolerance  
 ±0.1 ±.004  
 ±0.2 ±.008  
 ±0.3 ±.012

**REFERENCE DATA**

1. Max. switching power (AC resistive load)

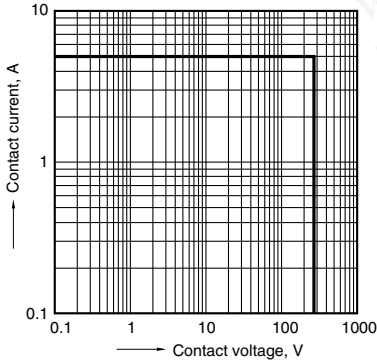

2. Coil temperature rise  
 Sample: LK1aF-12V, 6 pcs.  
 Point measured: coil inside  
 Contact current: 5 A

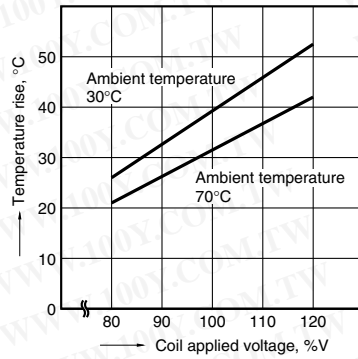

3. Ambient temperature characteristics  
 Contact current: 5 A

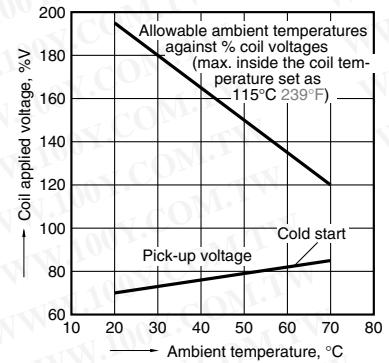

4. Life curve

Operation frequency: 20 times/min.  
 (ON/OFF = 1.5s: 1.5s)  
 Ambient temperature: room temperature

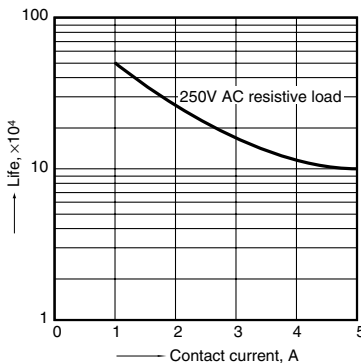

5-1. Operate & release time (without diode)  
 Sample: LK1aF-12V, 20 pcs.

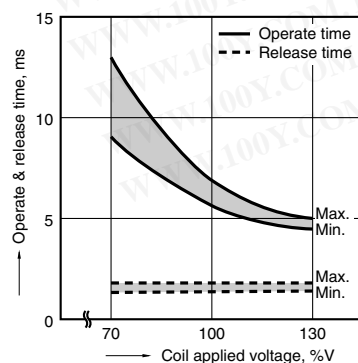

5-2. Operate & release time (with diode)  
 Sample: LK1aF-12V, 20 pcs.

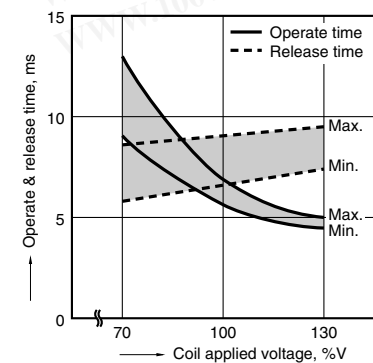

6-1. Electrical life test  
 (5 A 277 V AC, resistive load)  
 Sample: LK1aF-12V, 6 pcs.  
 Operation frequency: 20 times/min.  
 (ON/OFF = 1.5s: 1.5s)  
 Ambient temperature: 26°C 79°F

Circuit:

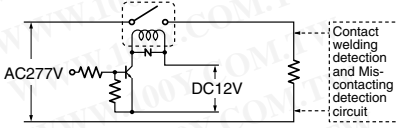

Change of pick-up and drop-out voltage

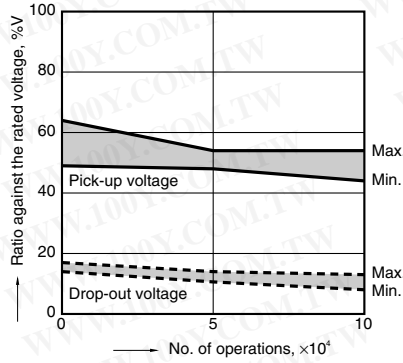

Change of contact resistance

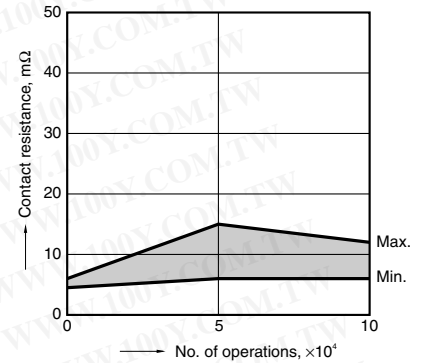

6-2. Electrical life test  
 (UL lamp load test TV-5)  
 Tested sample: LK1aF-12V, 6 pcs.  
 • Overload test  
 Load: 7.5 A 120 V AC (60 Hz),  
 Inrush: 111 A  
 Operation frequency: 10 times/min  
 (ON: OFF = 1 s: 5 s)  
 No. of operations: 50 ope.  
 • Endurance test  
 Load: 5A 120 V AC (60 Hz),  
 Inrush: 78 A  
 Operation frequency: 10 times/min  
 (ON: OFF = 1 s: 5 s)  
 No. of operations: 25,000 ope.

Change of pick-up and drop-out voltage

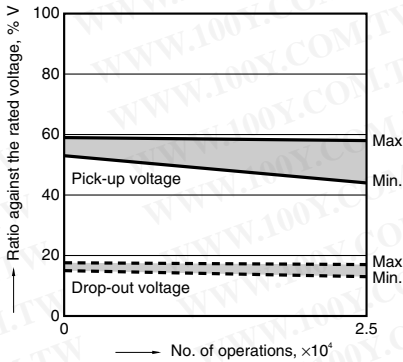

Change of contact resistance

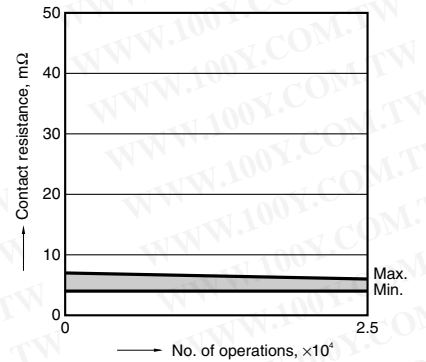

**NOTES**

**1. Cleaning**

This relay is not the sealed type, so it cannot be immersion cleaned. Be careful that flux does not overflow onto the PC board or penetrate inside the relay.

**2. Soldering**

We recommend the following soldering conditions.

- 1) Automatic soldering
  - \* Preheating: 100°C 212°F, within 2 mins (PC board solder surface)
  - \* Soldering: 260°C 500°F, within 5 s

**2) Hand soldering**

- \* Iron tip temperature: 280 to 300°C 536 to 571°F
- \* Soldering iron: 30 to 60W
- \* Soldering time: Within 3 s

**For Cautions for Use, see Relay Technical Information .**

勝特力材料 886-3-5753170  
 勝特力电子(上海) 86-21-54151736  
 勝特力电子(深圳) 86-755-83298787  
[Http://www.100y.com.tw](http://www.100y.com.tw)