

## VHF variable capacitance diode

BB132

### FEATURES

- High linearity
- Excellent matching to 1% DMA
- Very small plastic SMD package
- C28: 2.5 pF; ratio: 26.

### APPLICATIONS

- Electronic tuning in VHF television tuners, band A up to 160 MHz
- VCO.

### DESCRIPTION

The BB132 is a variable capacitance diode fabricated in planar technology, and encapsulated in the SOD323 very small plastic SMD package.

The excellent matching performance is achieved by gliding matching and a direct matching assembly procedure.

### ELECTRICAL CHARACTERISTICS

$T_j = 25\text{ }^\circ\text{C}$  unless otherwise specified.

SYMBOL	PARAMETER	CONDITIONS	MIN.	MAX.	UNIT
$I_R$	reverse current	$V_R = 30\text{ V}$ ; see Fig.3	–	10	nA
		$V_R = 30\text{ V}$ ; $T_j = 85\text{ }^\circ\text{C}$ ; see Fig.3	–	200	nA
$r_s$	diode series resistance	$f = 100\text{ MHz}$ ; note 1	–	2	$\Omega$
$C_d$	diode capacitance	$V_R = 0.5\text{ V}$ ; $f = 1\text{ MHz}$ ; see Figs 2 and 4	60	75	pF
		$V_R = 28\text{ V}$ ; $f = 1\text{ MHz}$ ; see Figs 2 and 4	2.3	2.75	pF
$\frac{C_{d(0.5V)}}{C_{d(28V)}}$	capacitance ratio	$f = 1\text{ MHz}$	24	30	
$\frac{\Delta C_d}{C_d}$	capacitance matching	$V_R = 0.5\text{ to }28\text{ V}$ ; in a sequence of 4 diodes (gliding)	–	1	%
		$V_R = 0.5\text{ to }28\text{ V}$ ; in a sequence of 15 diodes (gliding)	–	2	%

### Note

1.  $V_R$  is the value at which  $C_d = 30\text{ pF}$ .

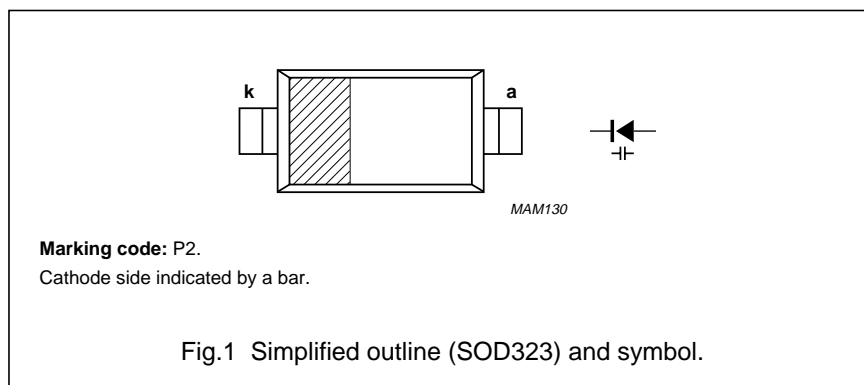

### LIMITING VALUES

In accordance with the Absolute Maximum Rating System (IEC 134).

SYMBOL	PARAMETER	MIN.	MAX.	UNIT
$V_R$	continuous reverse voltage	–	30	V
$I_F$	continuous forward current	–	20	mA
$T_{stg}$	storage temperature	–55	+150	$^\circ\text{C}$
$T_j$	operating junction temperature	–55	+125	$^\circ\text{C}$

VHF variable capacitance diode

BB132

GRAPHICAL DATA

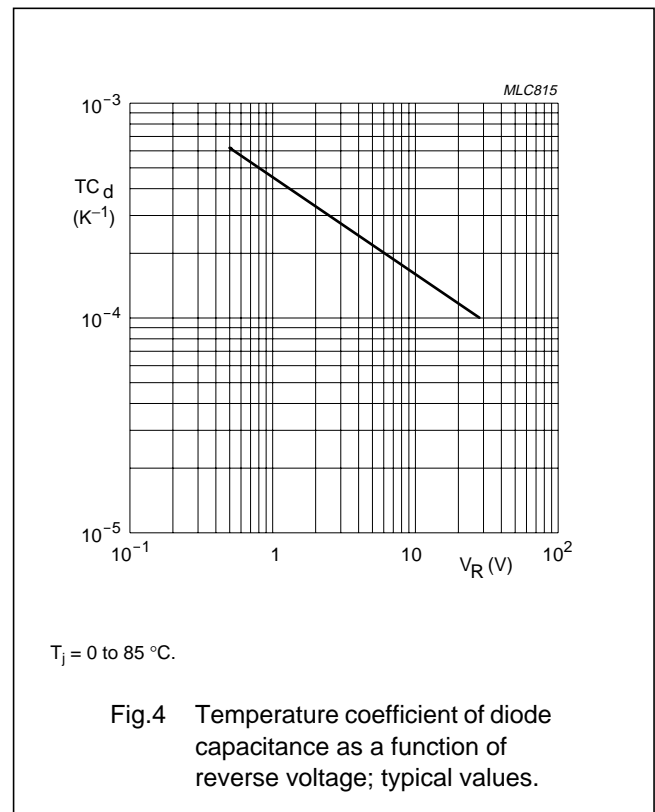
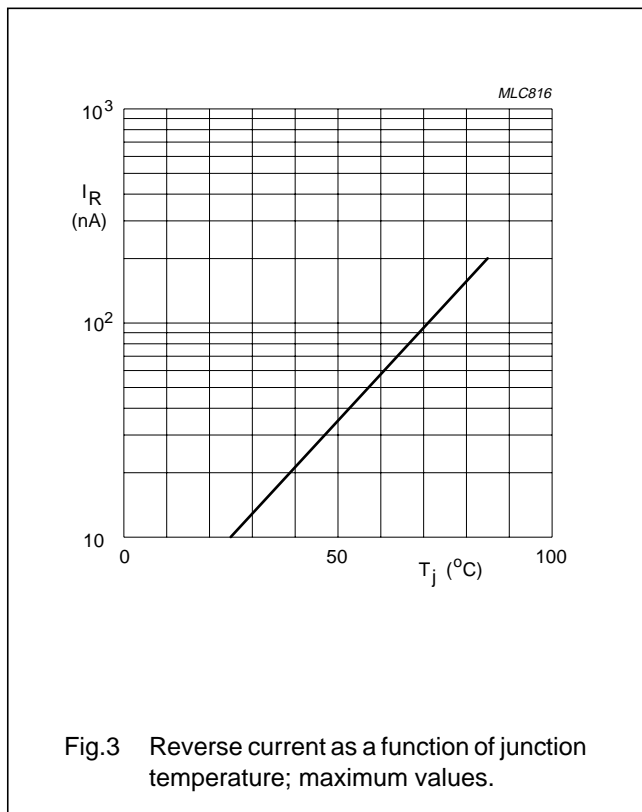
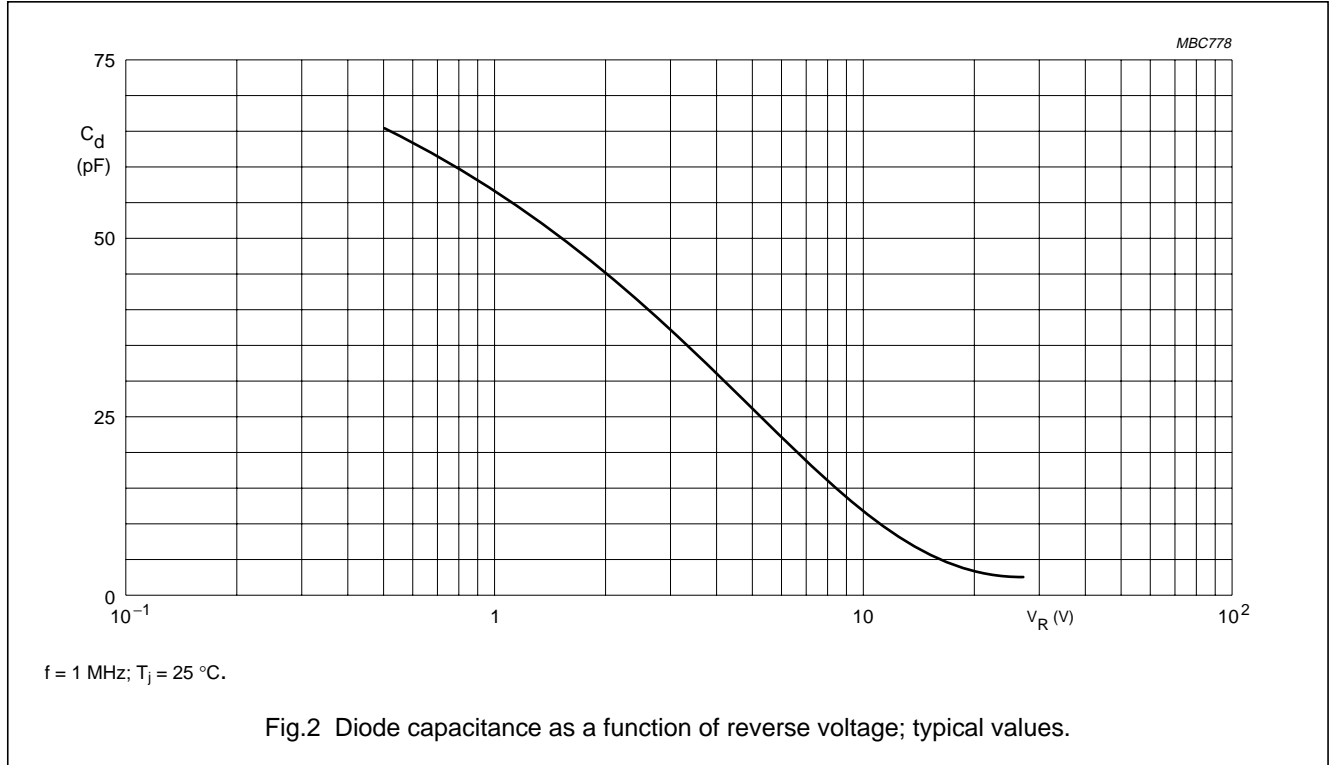

VHF variable capacitance diode

BB132

PACKAGE OUTLINE

Plastic surface mounted package; 2 leads

SOD323

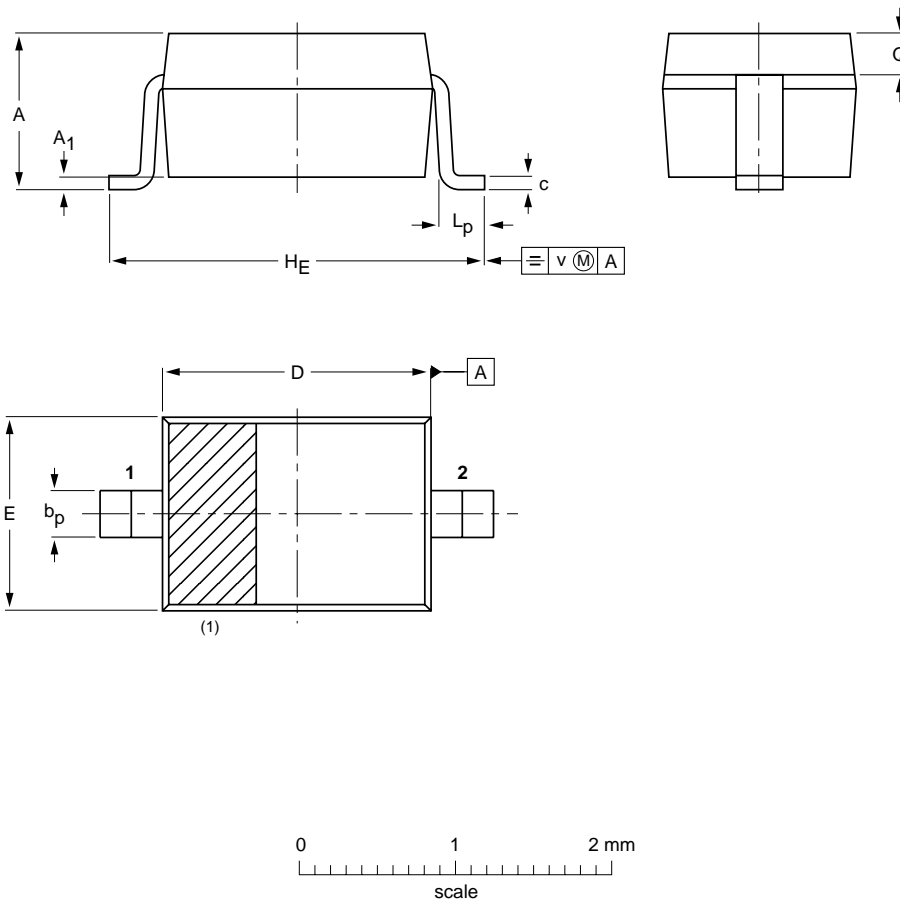

DIMENSIONS (mm are the original dimensions)

UNIT	A	A <sub>1</sub> max.	b <sub>p</sub>	c	D	E	H <sub>E</sub>	L <sub>p</sub>	Q	v
mm	1.1 0.8	+0.05 -0.05	0.40 0.25	0.25 0.10	1.8 1.6	1.35 1.15	2.7 2.3	0.45 0.15	0.25 0.15	0.2

Note

1. The marking bar indicates the cathode.

OUTLINE VERSION	REFERENCES			EUROPEAN PROJECTION	ISSUE DATE
	IEC	JEDEC	EIAJ		
SOD323					98-09-14