

# DATA SHEET

勝特力材料 886-3-5753170  
勝特力电子(上海) 86-21-54151736  
勝特力电子(深圳) 86-755-83298787  
[Http://www.100y.com.tw](http://www.100y.com.tw)

## 2N3553

### Silicon planar epitaxial overlay transistor

Product specification

Supersedes data of October 1981

File under Discrete Semiconductors, SC08a

1995 Oct 27

# Silicon planar epitaxial overlay transistor

## 2N3553

### APPLICATIONS

- The 2N3553 is intended for use in VHF and UHF transmitting applications.

### DESCRIPTION

The device is a silicon NPN overlay transistor in a TO-39 metal package with the collector connected to the case.

### PINNING - TO-39/3

PIN	DESCRIPTION
1	emitter
2	base
3	collector

勝特力材料 886-3-5753170  
 勝特力电子(上海) 86-21-54151736  
 勝特力电子(深圳) 86-755-83298787  
[Http://www.100y.com.tw](http://www.100y.com.tw)

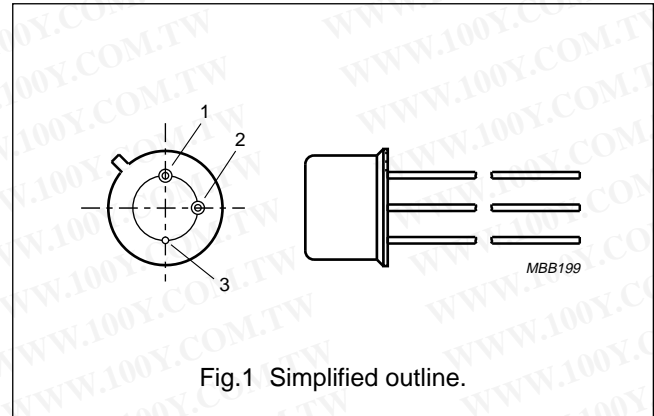

Fig.1 Simplified outline.

### QUICK REFERENCE DATA

SYMBOL	PARAMETER	CONDITIONS	MAX.	UNIT
$V_{CEX}$	collector-emitter voltage	$I_C \leq 200 \text{ mA}$ ; $V_{BE} = -1.5 \text{ V}$	65	V
$V_{CEO}$	collector-emitter voltage	open base; $I_C \leq 200 \text{ mA}$	40	V
$I_{CM}$	peak collector current		1.0	A
$P_{tot}$	total power dissipation	up to $T_{mb} = 25 \text{ }^\circ\text{C}$	7.0	W
$T_j$	junction temperature		200	$^\circ\text{C}$
$f_T$	transition frequency	$I_C = 125 \text{ mA}$ ; $V_{CE} = 28 \text{ V}$	500	—

### RF performance

f (MHz)	$V_{CE}$ (V)	$P_o$ (W)	$G_p$ (dB)	$\eta$ (%)
175	28	2.5	>10	>50

### WARNING

#### Product and environmental safety - toxic materials

This product contains beryllium oxide. The product is entirely safe provided that the BeO disc is not damaged. All persons who handle, use or dispose of this product should be aware of its nature and of the necessary safety precautions. After use, dispose of as chemical or special waste according to the regulations applying at the location of the user. It must never be thrown out with the general or domestic waste.

# Silicon planar epitaxial overlay transistor

2N3553

## LIMITING VALUES

In accordance with the Absolute Maximum Rating System (IEC 134).

SYMBOL	PARAMETER	CONDITIONS	MIN.	MAX.	UNIT
$V_{CBO}$	collector-base voltage	open emitter	–	65	V
$V_{CEX}$	collector-emitter voltage	$I_C \leq 200 \text{ mA}$ ; $V_{BE} = -1.5 \text{ V}$	–	65	V
$V_{CEO}$	collector-emitter voltage	open base; $I_C \leq 200 \text{ mA}$	–	40	V
$V_{EBO}$	emitter-base voltage	open collector	–	4	V
$I_C$	collector current (DC)		–	0.35	A
$I_{CM}$	peak collector current		–	1	A
$P_{tot}$	total power dissipation	up to $T_{mb} = 25 \text{ }^\circ\text{C}$	–	7	W
$T_{stg}$	storage temperature		–65	+200	$^\circ\text{C}$
$T_j$	junction temperature		–	200	$^\circ\text{C}$

## THERMAL CHARACTERISTICS

SYMBOL	PARAMETER	VALUE	UNIT
$R_{th\ j-mb}$	thermal resistance from junction to mounting base	25	K/W

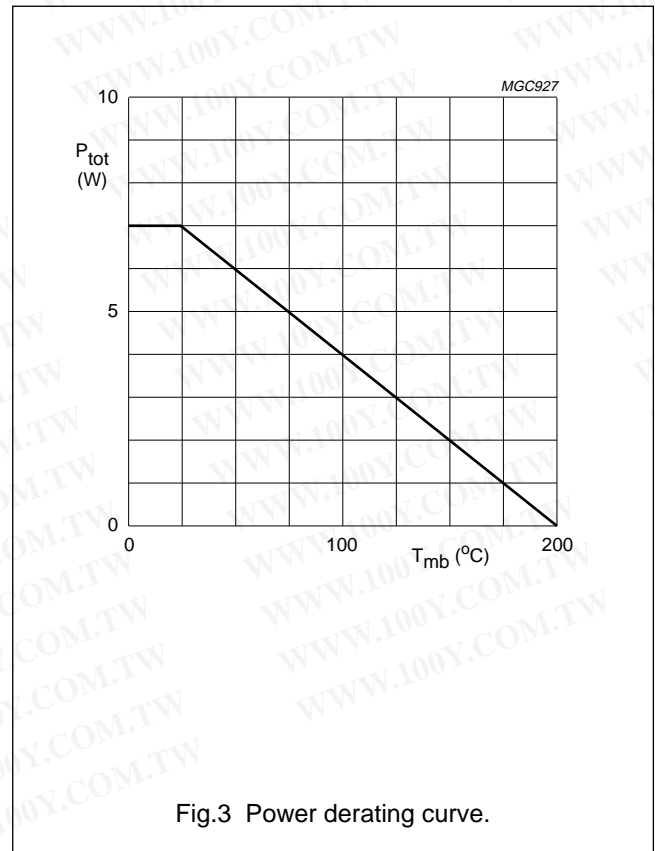
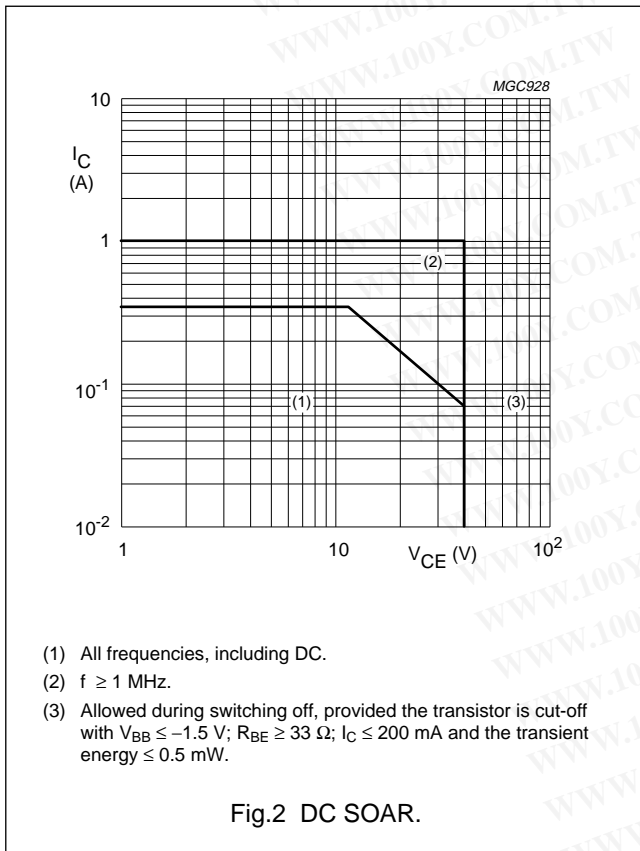

Silicon planar epitaxial overlay transistor

2N3553

CHARACTERISTICS

T<sub>j</sub> = 25 °C unless otherwise specified.

SYMBOL	PARAMETER	CONDITIONS	MIN.	TYP.	MAX.	UNIT
V <sub>(BR)CBO</sub>	collector-base breakdown voltage	open emitter; I <sub>C</sub> = 0.25 mA	65	–	–	V
V <sub>(BR)CEO</sub>	collector-emitter breakdown voltage	open base; I <sub>C</sub> up to 200 mA; note 1	40	–	–	V
V <sub>(BR)CEX</sub>	collector-emitter breakdown voltage	I <sub>C</sub> up to 200 mA; V <sub>BE</sub> = –1.5 V; R <sub>B</sub> = 33 Ω; note 1	65	–	–	V
V <sub>(BR)EBO</sub>	emitter-base breakdown voltage	open collector; I <sub>E</sub> = 0.25 mA	4	–	–	V
V <sub>BE</sub>	base-emitter voltage	I <sub>C</sub> = 250 mA; V <sub>CE</sub> = 5 V	–	–	1.5	V
V <sub>CEsat</sub>	collector-emitter saturation voltage	I <sub>C</sub> = 250 mA; I <sub>B</sub> = 50 mA	–	–	1.0	V
I <sub>CEO</sub>	collector leakage current	open base; V <sub>CE</sub> = 30 V	–	–	0.1	mA
h <sub>FE</sub>	DC current gain	V <sub>CE</sub> = 5 V; I <sub>C</sub> = 125 mA	15	–	200	
		V <sub>CE</sub> = 5 V; I <sub>C</sub> = 250 mA	10	–	100	
f <sub>T</sub>	transition frequency	I <sub>C</sub> = 125 mA; V <sub>CE</sub> = 28 V	–	500	–	MHz
Rho <sub>(ie)</sub>	real part of input impedance	I <sub>C</sub> = 125 mA; V <sub>CE</sub> = 28 V; f = 200 MHz	–	–	20	Ω
C <sub>c</sub>	collector capacitance	V <sub>CB</sub> = 28 V; I <sub>E</sub> = i <sub>e</sub> = 0; f = 1 MHz	–	–	10	pF

Note

1. Pulsed through an inductor of 25 mH; δ = 0.5; f = 50 Hz.

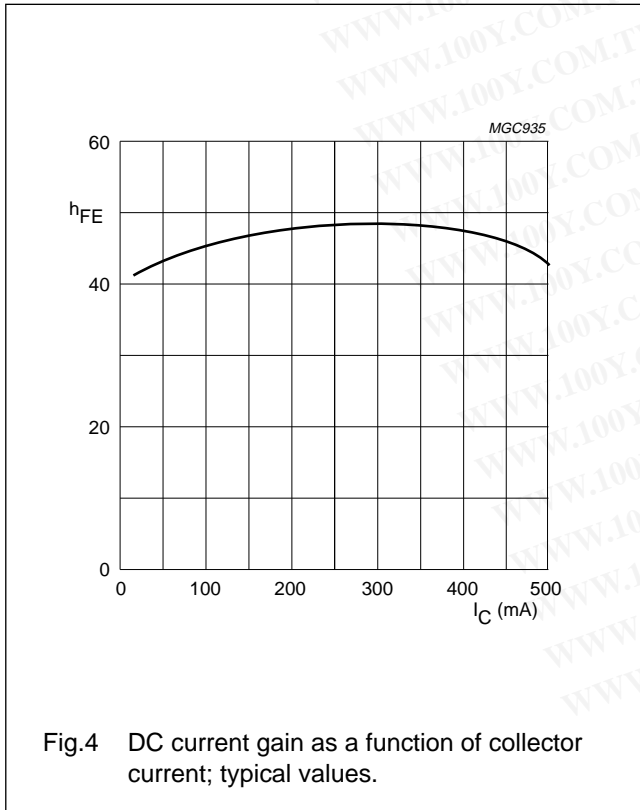

Fig.4 DC current gain as a function of collector current; typical values.

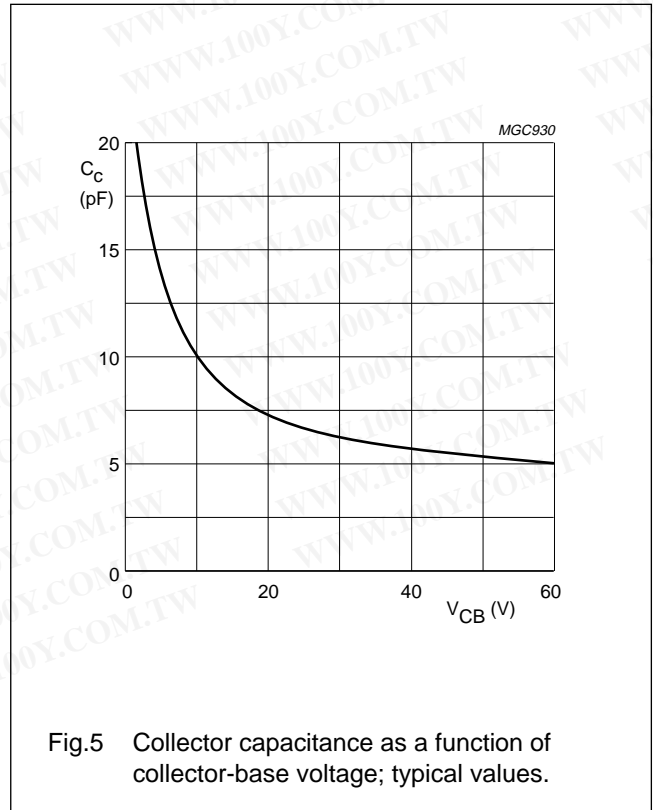

Fig.5 Collector capacitance as a function of collector-base voltage; typical values.

勝特力材料 886-3-5753170  
 勝特力电子(上海) 86-21-54151736  
 勝特力电子(深圳) 86-755-83298787  
[Http://www.100y.com.tw](http://www.100y.com.tw)

Silicon planar epitaxial overlay transistor

2N3553

APPLICATION INFORMATION

RF performance at  $T_{mb} = 25\text{ }^\circ\text{C}$ .

f (MHz)	$V_{CE}$ (V)	$P_o$ (W)	$G_p$ (dB)	$\eta$ (%)
175	28	2.5	>10	>50

Ruggedness

The transistor is capable of withstanding a load mismatch corresponding to  $VSWR = 3 : 1$  varied through all phases, under the conditions:  $V_{CE} = 28\text{ V}$ ;  $f = 175\text{ MHz}$ ;  $T_{mb} = 25\text{ }^\circ\text{C}$ ;  $P_o = 2.5\text{ W}$ .

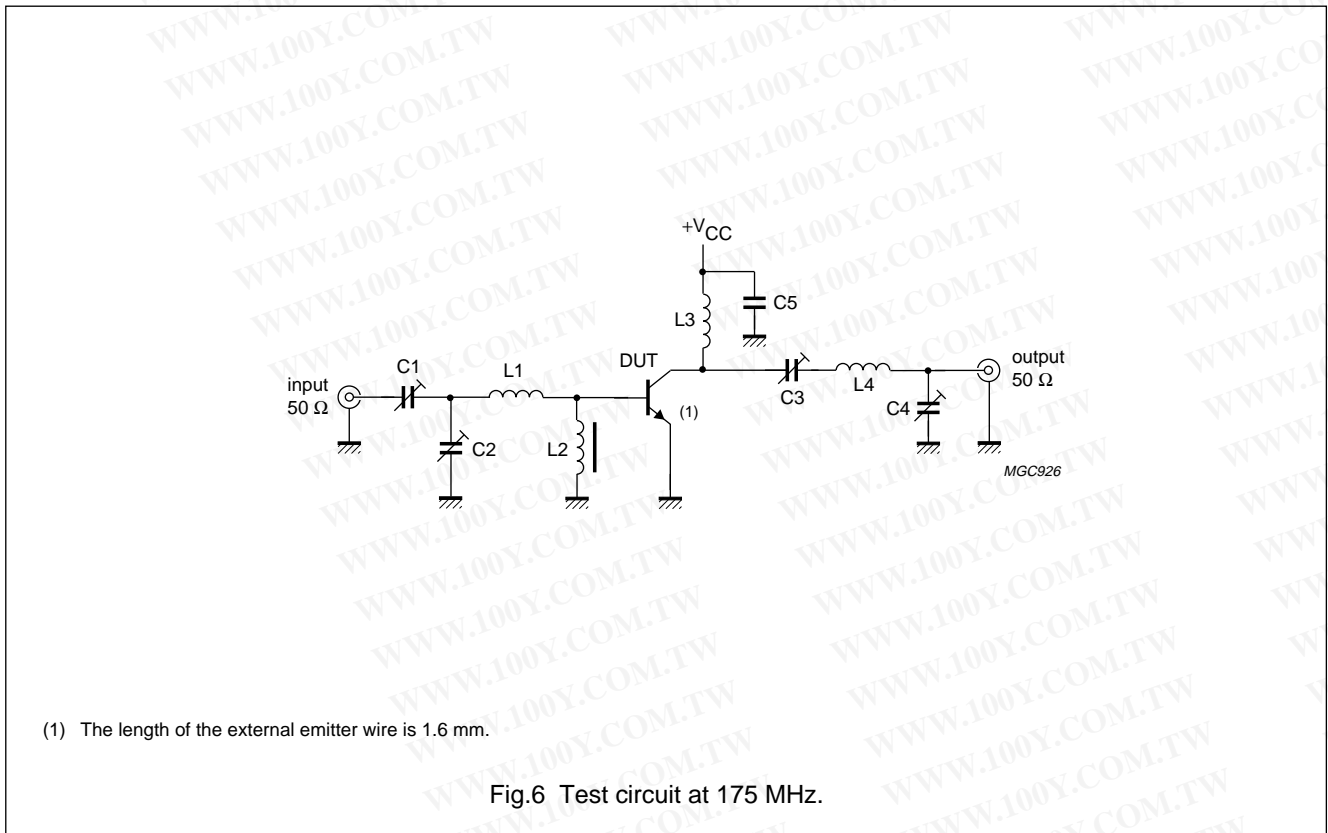

Silicon planar epitaxial overlay transistor

2N3553

List of components (see Fig.6)

COMPONENT	DESCRIPTION	VALUE	DIMENSIONS	CATALOGUE No.
C1, C2, C3, C4	air trimmer capacitor	4 to 29 pF		
C5	polyester capacitor	10 nF		
L1	1 turn 1.0 mm copper wire		int. diameter 10 mm; leads 2 × 10 mm	
L2	Ferroxcube choke coil	Z = 550 Ω ±20%; f = 175 MHz		4312 020 36640
L3	15 turns enamelled 0.7 mm copper wire		int. diameter 4 mm; closely wound	
L4	3 turns enamelled 1.5 mm copper wire		int. diameter 12 mm; leads 2 × 20 mm; closely wound	

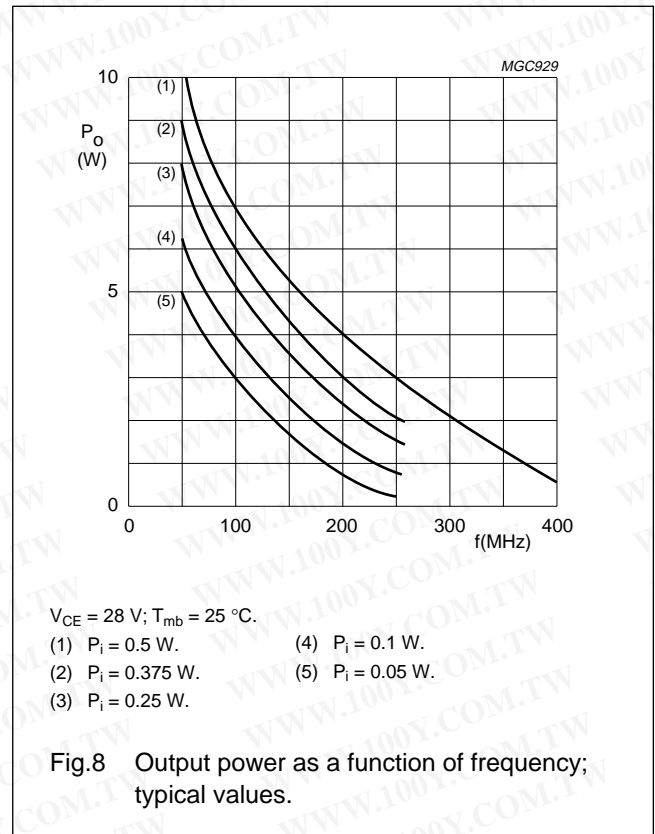
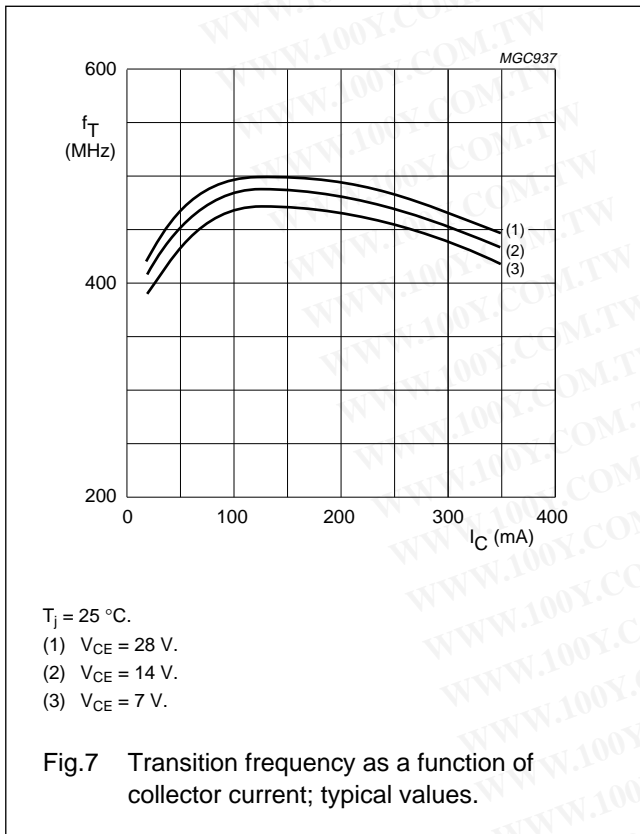

Silicon planar epitaxial  
overlay transistor

2N3553

PACKAGE OUTLINE

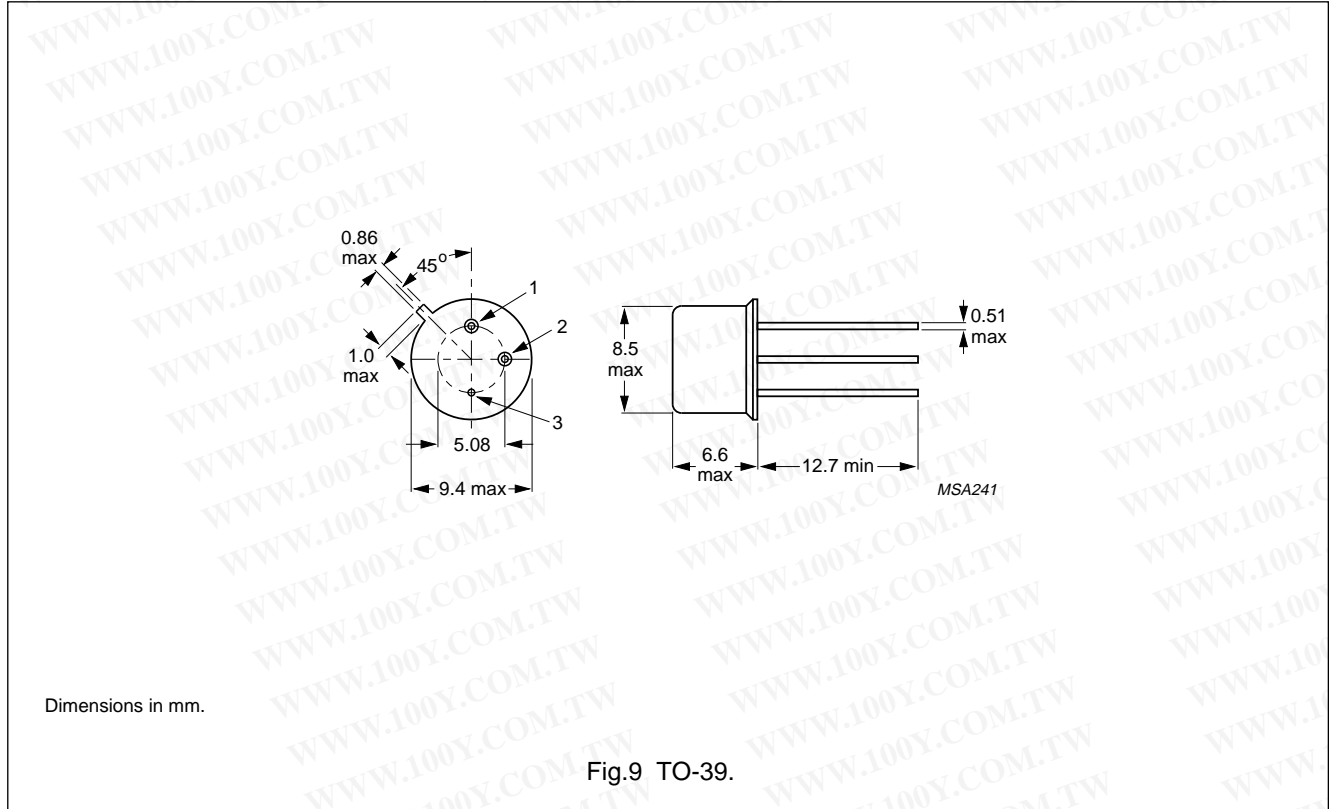

## Silicon planar epitaxial overlay transistor

2N3553

### DEFINITIONS

<b>Data Sheet Status</b>	
Objective specification	This data sheet contains target or goal specifications for product development.
Preliminary specification	This data sheet contains preliminary data; supplementary data may be published later.
Product specification	This data sheet contains final product specifications.
<b>Limiting values</b>	
Limiting values given are in accordance with the Absolute Maximum Rating System (IEC 134). Stress above one or more of the limiting values may cause permanent damage to the device. These are stress ratings only and operation of the device at these or at any other conditions above those given in the Characteristics sections of the specification is not implied. Exposure to limiting values for extended periods may affect device reliability.	
<b>Application information</b>	
Where application information is given, it is advisory and does not form part of the specification.	

### LIFE SUPPORT APPLICATIONS

These products are not designed for use in life support appliances, devices, or systems where malfunction of these products can reasonably be expected to result in personal injury. Philips customers using or selling these products for use in such applications do so at their own risk and agree to fully indemnify Philips for any damages resulting from such improper use or sale.