

DATA SHEET

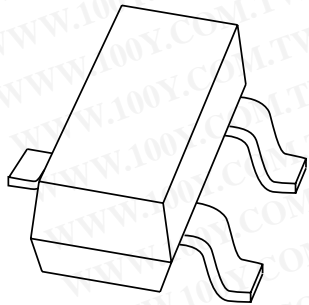

勝特力材料 886-3-5753170
勝特力电子(上海) 86-21-54151736
勝特力电子(深圳) 86-755-83298787
[Http://www.100y.com.tw](http://www.100y.com.tw)

PMBT3906 PNP switching transistor

Product specification

Supersedes data of September 1994

File under Discrete Semiconductors, SC04

1997 May 05

PNP switching transistor

PMBT3906

FEATURES

- Low current (max. 100 mA)
- Low voltage (max. 40 V).

APPLICATIONS

- Telephony and professional communication equipment.

DESCRIPTION

PNP switching transistor in a SOT23 plastic package.
NPN complement: PMBT3904.

MARKING

TYPE NUMBER	MARKING CODE
PMBT3906	p2A

PINNING

PIN	DESCRIPTION
1	base
2	emitter
3	collector

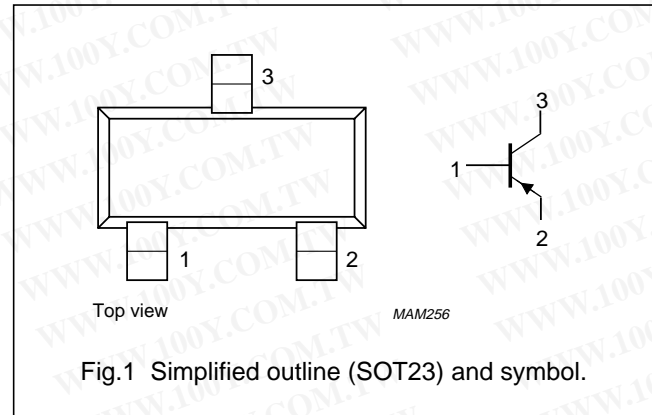

QUICK REFERENCE DATA

SYMBOL	PARAMETER	CONDITIONS	MIN.	MAX.	UNIT
V_{CBO}	collector-base voltage	open emitter	–	–40	V
V_{CEO}	collector-emitter voltage	open base	–	–40	V
I_C	collector current (DC)		–	–100	mA
P_{tot}	total power dissipation	$T_{amb} \leq 25\text{ }^\circ\text{C}$	–	250	mW
h_{FE}	DC current gain	$I_C = -10\text{ mA}; V_{CE} = -1\text{ V}$	100	300	
f_T	transition frequency	$I_C = -10\text{ mA}; V_{CE} = -20\text{ V}; f = 100\text{ MHz}$	250	–	MHz
t_{off}	turn-off time	$I_{Con} = -10\text{ mA}; I_{Bon} = -1\text{ mA}; I_{Boff} = 1\text{ mA}$	–	300	ns

勝特力材料 886-3-5753170
 勝特力电子(上海) 86-21-54151736
 勝特力电子(深圳) 86-755-83298787
[Http://www.100y.com.tw](http://www.100y.com.tw)

PNP switching transistor

PMBT3906

LIMITING VALUES

In accordance with the Absolute Maximum Rating System (IEC 134).

SYMBOL	PARAMETER	CONDITIONS	MIN.	MAX.	UNIT
V_{CBO}	collector-base voltage	open emitter	–	–40	V
V_{CEO}	collector-emitter voltage	open base	–	–40	V
V_{EBO}	emitter-base voltage	open collector	–	–6	V
I_C	collector current (DC)		–	–100	mA
I_{CM}	peak collector current		–	–200	mA
I_{BM}	peak base current		–	–100	mA
P_{tot}	total power dissipation	$T_{amb} \leq 25\text{ °C}$; note 1	–	250	mW
T_{stg}	storage temperature		–65	+150	°C
T_j	junction temperature		–	+150	°C
T_{amb}	operating ambient temperature		–65	+150	°C

Note

1. Transistor mounted on an FR4 printed-circuit board.

THERMAL CHARACTERISTICS

SYMBOL	PARAMETER	CONDITIONS	VALUE	UNIT
$R_{th\ j-a}$	thermal resistance from junction to ambient	note 1	500	K/W

Note

1. Transistor mounted on an FR4 printed-circuit board.

勝特力材料 886-3-5753170
 勝特力电子(上海) 86-21-54151736
 勝特力电子(深圳) 86-755-83298787
[Http://www.100y.com.tw](http://www.100y.com.tw)

PNP switching transistor

PMBT3906

CHARACTERISTICS

$T_{amb} = 25\text{ }^{\circ}\text{C}$ unless otherwise specified.

SYMBOL	PARAMETER	CONDITIONS	MIN.	MAX.	UNIT
I_{CBO}	collector cut-off current	$I_E = 0; V_{CB} = -30\text{ V}$	–	–50	nA
I_{EBO}	emitter cut-off current	$I_C = 0; V_{EB} = -6\text{ V}$	–	–50	nA
h_{FE}	DC current gain	$V_{CE} = -1\text{ V}$; see Fig.2 $I_C = -0.1\text{ mA}$ $I_C = -1\text{ mA}$ $I_C = -10\text{ mA}$ $I_C = -50\text{ mA}$ $I_C = -100\text{ mA}$	60 80 100 60 30	– – 300 – –	
V_{CEsat}	collector-emitter saturation voltage	$I_C = -10\text{ mA}; I_B = -1\text{ mA}$	–	–200	mV
		$I_C = -50\text{ mA}; I_B = -5\text{ mA}$	–	–200	mV
V_{BEsat}	base-emitter saturation voltage	$I_C = -10\text{ mA}; I_B = -1\text{ mA}$	–	–850	mV
		$I_C = -50\text{ mA}; I_B = -5\text{ mA}$	–	–950	mV
C_c	collector capacitance	$I_E = i_e = 0; V_{CB} = -5\text{ V}; f = 1\text{ MHz}$	–	4.5	pF
C_e	emitter capacitance	$I_C = i_c = 0; V_{EB} = -500\text{ mV}; f = 1\text{ MHz}$	–	10	pF
f_T	transition frequency	$I_C = -10\text{ mA}; V_{CE} = -20\text{ V}; f = 100\text{ MHz}$	250	–	MHz
F	noise figure	$I_C = -100\text{ }\mu\text{A}; V_{CE} = -5\text{ V}; R_S = 1\text{ k}\Omega;$ $f = 10\text{ Hz to }15.7\text{ kHz}$	–	4	dB
Switching times (between 10% and 90% levels); see Fig.3					
t_{on}	turn-on time	$I_{Con} = -10\text{ mA}; I_{Bon} = -1\text{ mA}; I_{Boff} = 1\text{ mA}$	–	65	ns
t_d	delay time		–	35	ns
t_r	rise time		–	35	ns
t_{off}	turn-off time		–	300	ns
t_s	storage time		–	225	ns
t_f	fall time		–	75	ns

勝特力材料 886-3-5753170
 勝特力电子(上海) 86-21-54151736
 勝特力电子(深圳) 86-755-83298787
[Http://www.100y.com.tw](http://www.100y.com.tw)

PNP switching transistor

PMBT3906

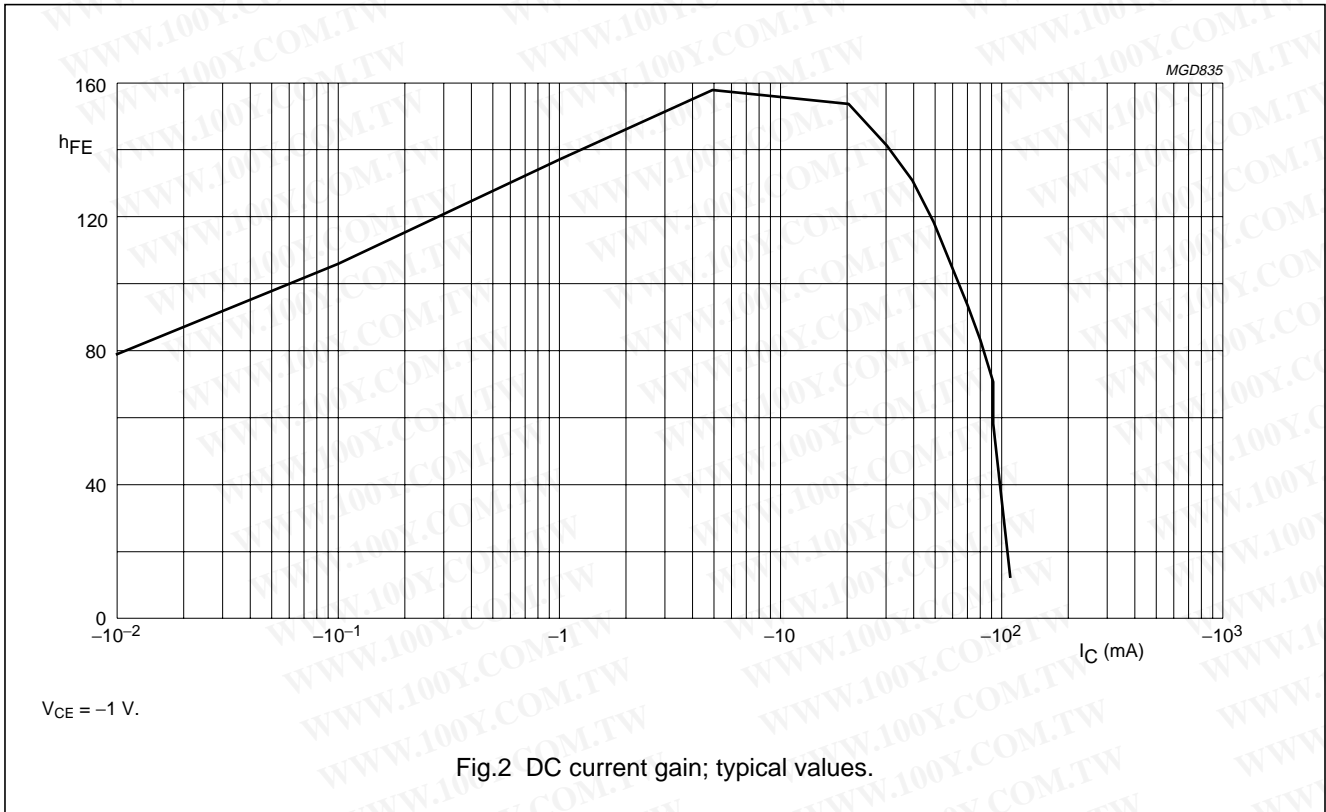

勝特力材料 886-3-5753170
 勝特力电子(上海) 86-21-54151736
 勝特力电子(深圳) 86-755-83298787
[Http://www.100y.com.tw](http://www.100y.com.tw)

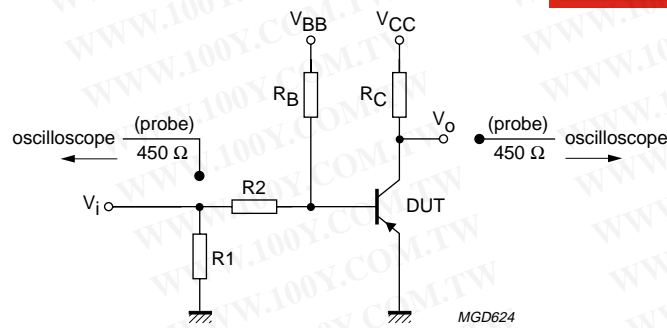

$V_i = 5 V; T = 500 \mu s; t_p = 10 \mu s; t_r = t_f \leq 3 ns.$
 $R_1 = 56 \Omega; R_2 = 2.5 k\Omega; R_B = 3.9 k\Omega; R_C = 270 \Omega.$
 $V_{BB} = 1.9 V; V_{CC} = -3 V.$
 Oscilloscope: input impedance $Z_i = 50 \Omega.$

Fig.3 Test circuit for switching times.

PNP switching transistor

PMBT3906

PACKAGE OUTLINE

Plastic surface mounted package; 3 leads

SOT23

勝特力材料 886-3-5753170
 勝特力电子(上海) 86-21-54151736
 勝特力电子(深圳) 86-755-83298787
[Http://www.100y.com.tw](http://www.100y.com.tw)

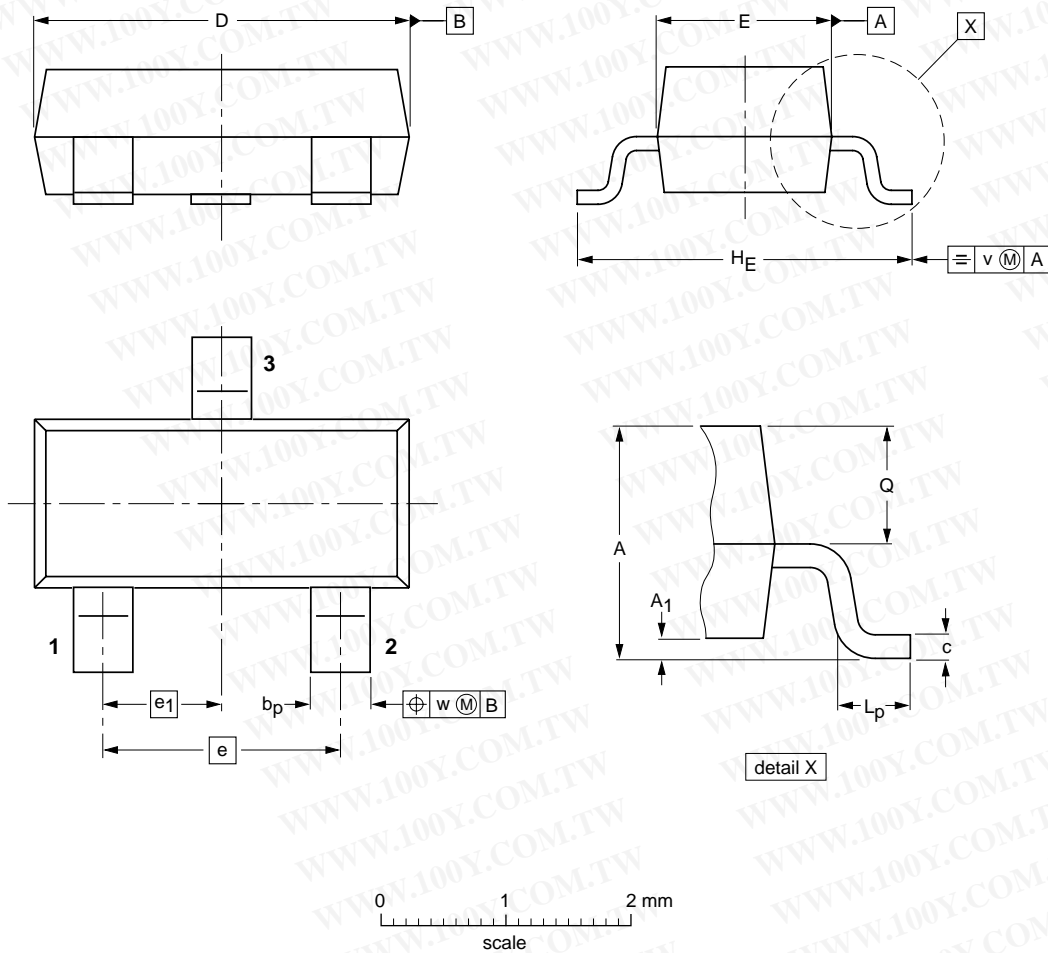

DIMENSIONS (mm are the original dimensions)

UNIT	A	A ₁ max.	b _p	c	D	E	e	e ₁	H _E	L _p	Q	v	w
mm	1.1 0.9	0.1	0.48 0.38	0.15 0.09	3.0 2.8	1.4 1.2	1.9	0.95	2.5 2.1	0.45 0.15	0.55 0.45	0.2	0.1

OUTLINE VERSION	REFERENCES				EUROPEAN PROJECTION	ISSUE DATE
	IEC	JEDEC	EIAJ			
SOT23						97-02-28

PNP switching transistor

PMBT3906

DEFINITIONS

Data sheet status	
Objective specification	This data sheet contains target or goal specifications for product development.
Preliminary specification	This data sheet contains preliminary data; supplementary data may be published later.
Product specification	This data sheet contains final product specifications.
Limiting values	
Limiting values given are in accordance with the Absolute Maximum Rating System (IEC 134). Stress above one or more of the limiting values may cause permanent damage to the device. These are stress ratings only and operation of the device at these or at any other conditions above those given in the Characteristics sections of the specification is not implied. Exposure to limiting values for extended periods may affect device reliability.	
Application information	
Where application information is given, it is advisory and does not form part of the specification.	

LIFE SUPPORT APPLICATIONS

These products are not designed for use in life support appliances, devices, or systems where malfunction of these products can reasonably be expected to result in personal injury. Philips customers using or selling these products for use in such applications do so at their own risk and agree to fully indemnify Philips for any damages resulting from such improper use or sale.

勝特力材料 886-3-5753170
 勝特力电子(上海) 86-21-54151736
 勝特力电子(深圳) 86-755-83298787
[Http://www.100y.com.tw](http://www.100y.com.tw)