

RC224ATL/224ATLV

Embedded Modem Family

The new Conexant RC224ATL utilizes a new integrated data pump/controller to allow the device to directly connect to host processors that are 3.3 V I/O capable. The codec used in the new part is the same as the codec used in the existing RC224ATL. The new device is form, fit, and function compatible with the existing device. This means there are no hardware and software differences between the existing and the new part, with one exception. The 3.3 V I/O capable part incorporates 3.3 V compatible digital I/O buffers, hence requiring 3.3 V digital supply instead of 5 V digital supply.

In addition, unlike the current version of RC224ATL, the new part provides both data and fax capabilities.

Data modes, controlled by an industry standard 2400 AT command set, can transmit and receive up to 2400 bps.

Fax modes, controlled by a built-in EIA-578 Class 1 command interface, provide Group 3 transmit and receive functions.

Distinguishing Features

- Data modes
 - CCITT V.22 bis (2400 bps), V.22 (1200 bps)
 - Bell 212A (1200 bps) and 103 (300 bps)
 - Enhanced AT commands
- Group 3 fax modes
 - V.29 (9600/7200 bps) transmit
 - V.27 ter (4800/2400 bps) transmit and receive
 - V.21 Channel 2 (300 bps) transmit and receive
- EIA-578 Service Class 1 commands
- V.42/MNP2-4 and V.42 bis/MNP 5 can be supported through host software without additional hardware
- Data/fax discriminator and auto answering
- Communications software compatible
- Integrated call progress and dialing
- No external microcomputer or memory required
- Parallel or serial asynchronous DTE interface
- A/A1 relay control
- NVRAM interface allows storage of two user configurations and four 36-digit dial strings
- Automatic adaptive/fixd compromise equalization
- Programmable sleep mode and wake-up
- Full-duplex data mode test capabilities: Analog loop, local digital loop, and remote digital loop
- Half-duplex fax mode test capabilities
- Automatic format/speed sensing
- Low power consumption (typical)
 - Operating: 100 mW
 - Sleep—Idle: 25 mW
 - Sleep—Stop: 5 mW
- Single +5 V power supply or Dual + 3.3 VDD and + 5 VAA power supplies
- Package options:
 - 68-pin plastic leaded chip carrier (PLCC)
 - 100-pin plastic quad flat pack (PQFP)

Functional Block Diagram

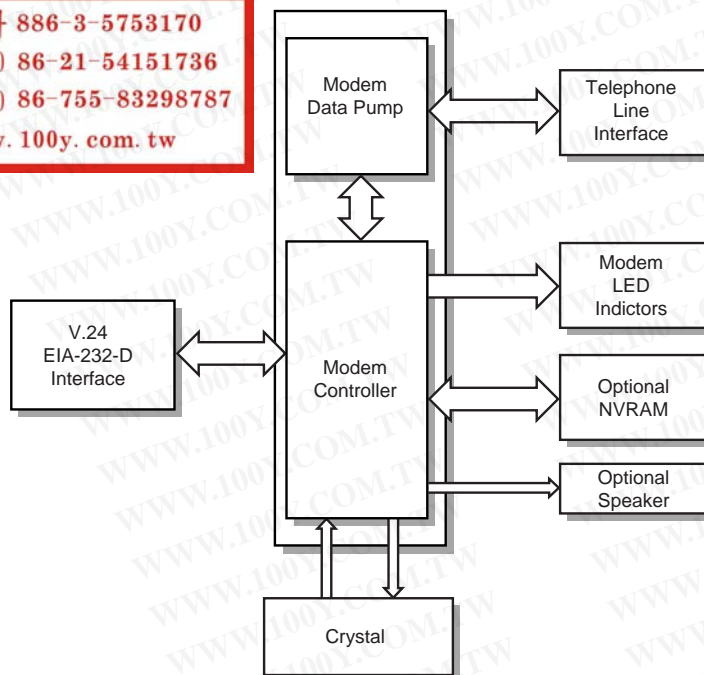

Ordering Information

Marketing Number	Manufacturing Number	DSP Die Number	I/O & VCC	VAA/Codec	Package
RC224ATL	R6781-11	L2501	5V	5V	68 PLCC
RC224ATL	R6781-12	L2501	5V	5V	100 PQFP
RC224ATL	R6781-13	L2503	5V	5V	68 PLCC
RC224ATL	R6781-14	L2503	5V	5V	100 PQFP
RC224ATLV	R6781-21	L2531	3V	5V	68 PLCC
RC224ATLV	R6781-22	L2531	3V	5V	100 PQFP

Replacement Matrix

Marketing Number	Manufacturing Number	Package	Replaces
RC224ATL	R6781-11	68 PLCC	RC224ATL/V (R6641-14), RC224ATL (R6641-15), RC224ATL/VN (R6641-16), RC224ATLN (R6641-17), RC224ATL/VE (R6641-24), RC224ATLE (R6641-25)
RC224ATL	R6781-12	100 PQFP	RC224ATL/V (R6641-18), RC224ATL (R6641-19), RC224ATL/VN (R6641-20), RC224ATLN (R6641-21), RC224ATL/VE (R6641-26), RC224ATLE (R6641-27)
RC224ATL	R6781-13	68 PLCC	RC224ATL/VN (R6641-36), RC224ATL/V (R6641-37), RC224ATLN (R6641-38), RC224ATL (R6641-39)
RC224ATL	R6781-14	100 PQFP	RC224ATL/VN (R6641-40), RC224ATL/V (R6641-41), RC224ATL (R6641-43)
RC224ATLV	R6781-21	68 PLCC	N/A: New 3.3 V Digital I/O
RC224ATLV	R6781-22	100 PQFP	N/A: New 3.3 V Digital I/O

Information provided by Conexant Systems, Inc. (Conexant) is believed to be accurate and reliable. However, no responsibility is assumed by Conexant for its use, nor any infringement of patents or other rights of third parties which may result from its use. No license is granted by implication or otherwise under any patent rights of Conexant other than for circuitry embodied in Conexant products. Conexant reserves the right to change circuitry at any time without notice. This document is subject to change without notice.

Conexant and "What's Next in Communications Technologies" are trademarks of Conexant Systems, Inc.

Product names or services listed in this publication are for identification purposes only, and may be trademarks or registered trademarks of their respective companies. All other marks mentioned herein are the property of their respective holders.

© 1999 Conexant Systems, Inc.
Printed in U.S.A.
All Rights Reserved

Reader Response: To improve the quality of our publications, we welcome your feedback. Please send comments or suggestions via e-mail to [Conexant Reader Response@conexant.com](mailto:Conexant.Reader.Response@conexant.com). Sorry, we can't answer your technical questions at this address. Please contact your local Conexant [sales office](#) or local field applications engineer if you have technical questions.

勝特力材料 886-3-5753170
 勝特力电子(上海) 86-21-54151736
 勝特力电子(深圳) 86-755-83298787
[Http://www.100y.com.tw](http://www.100y.com.tw)

Table of Contents

List of Figures	vii
List of Tables	ix
1.0 Functional Description	1-1
1.1 Overview	1-1
1.2 Technical Specifications	1-1
1.2.1 General	1-1
1.2.2 Configurations and Rates	1-2
1.2.3 Operation	1-3
1.2.3.1 Data Modes	1-3
1.2.3.2 Fax Modes	1-3
1.2.4 Data/Fax Auto Answering	1-3
1.2.5 Data Modulation	1-3
1.2.6 Equalization	1-3
1.2.7 Scrambler/Descrambler	1-3
1.2.8 Transmit Level	1-4
1.2.9 Transmit Tones	1-4
1.2.10 Receive Level	1-4
1.2.11 Receiver Tracking	1-4
1.2.12 Low Power Sleep Mode	1-5
2.0 Hardware Interface	2-1
2.1 Hardware Interface	2-6
2.1.1 Parallel Interface	2-6
2.1.2 Serial/Indicator Interface	2-12
2.1.3 Speaker Interface	2-12
2.1.4 Line Interface	2-12
2.2 Additional Information	2-12

3.0	Pin Descriptions	3-1
4.0	AT Commands	4-1
5.0	S Registers	5-1
6.0	Operation	6-1
6.1	Data Modes	6-1
6.1.1	Data Mode Selection	6-1
6.1.2	Data Modem Processing	6-1
6.1.3	Call Origination	6-2
6.1.4	Call Answering	6-2
6.1.5	Call Termination	6-2
6.2	Fax Modes	6-3
6.2.1	Fax Mode Selection	6-3
6.2.2	Fax Mode Processing	6-3
6.2.3	Fax Origination	6-3
6.2.4	Fax Answering	6-3
6.2.5	Fax Data Transmission	6-4
6.2.6	Fax Data Reception	6-4
6.2.7	Fax Control Transmission	6-4
6.2.8	Fax Control Reception	6-5
6.2.9	Fax I/O Processing	6-5
6.3	Fax Enhanced Flow Control	6-7
6.3.1	Parallel/Serial Interface Selection	6-7
6.3.2	Fax V.42 Buffer Sizes	6-7
6.3.3	DTE Flow Control Operation	6-8
6.4	Data/Fax Auto Answering	6-8
6.5	Call Progress	6-12
6.5.1	Call Progress Algorithms	6-12
6.5.2	Ring Detection	6-13
7.0	Electrical/Mechanical Specifications	7-1
7.1	Interfacing the RC224ATLV	7-1
7.2	Environmental Requirements	7-1
7.3	Interface Timing and Waveforms	7-2
Appendix A:	RC224ATF Modem Designs	A-1
A.1	68-Pin PLCC Design for Serial Interface	A-1
A.2	68-Pin PLCC Design for Parallel Interface	A-6
Appendix B:	Acronyms/Abbreviations	B-1

List of Figures

Figure 2-1.	RC224ATLV Signals—Parallel Interface	2-2
Figure 2-2.	RC224ATLV Signals—Serial Interface	2-3
Figure 3-1.	68-Pin PLCC Package—Serial	3-1
Figure 3-2.	68-Pin PLCC Package—Parallel	3-2
Figure 3-3.	100-Pin PQFP Package—Serial	3-3
Figure 3-4.	100-Pin PQFP Package—Parallel	3-4
Figure 3-5.	NVRAM Timing	3-20
Figure 7-1.	Timing Waveform	7-3
Figure 7-2.	68-Pin PLCC	7-7
Figure 7-3.	100-Pin PQFP	7-9
Figure A-1.	Serial Interface Design	A-2
Figure A-2.	Serial Interface Design DAA	A-3
Figure A-3.	Parallel Interface Design	A-7
Figure A-4.	Parallel Interface Design DAA	A-8

勝特力材料 886-3-5753170
 勝特力电子(上海) 86-21-54151736
 勝特力电子(深圳) 86-755-83298787
[Http://www.100y.com.tw](http://www.100y.com.tw)

List of Tables

Table 1-1.	Configurations and Rates	1-2
Table 1-2.	Data Rates vs. Connection Modem Rate	1-3
Table 1-3.	Dial Digits/Tone Pairs	1-4
Table 1-4.	Current and Power Requirements	1-5
Table 2-1.	Parallel Interface Registers	2-4
Table 2-2.	Programmable Baud Rates	2-12
Table 3-1.	RC224ATL/224ATLV 68-Pin PLCC Pin Assignments—Serial Mode	3-5
Table 3-2.	RC224ATLV 68-Pin PLCC Pin Assignments—Parallel Mode	3-6
Table 3-3.	RC224ATL/224ATLV 100-Pin PQFP Pin Assignments—Serial	3-7
Table 3-4.	RC224ATL/224ATLV 100-Pin PQFP Pin Assignments—Parallel	3-11
Table 3-5.	Hardware Interface Signal Definitions	3-15
Table 4-1.	Result Codes and Messages	4-1
Table 4-2.	AT Command Set Summary	4-2
Table 4-3.	Fax Command Set Summary	4-7
Table 5-1.	S Register Summary	5-2
Table 5-2.	S Register Description	5-3
Table 6-1.	Data Rate Selection	6-1
Table 6-2.	Terminal Called by a 1200 bps Data Modem	6-10
Table 6-3.	Terminal Called by a Fax Machine	6-11
Table 6-4.	Tone Characteristics	6-12
Table 6-5.	Fax Class 1 Calling Sequence	6-13
Table 6-6.	Fax Class 1 Answering Sequence	6-15
Table 7-1.	Environmental Specifications	7-1
Table 7-2.	Timing—Host Bus Interface	7-2
Table 7-3.	Current and Power Requirements	7-4
Table 7-4.	Absolute Maximum Ratings	7-4
Table 7-5.	Digital Interface Characteristics	7-5
Table 7-6.	Analog Interface Characteristics	7-6
Table 7-7.	68-Pin PLCC Dimensions	7-8
Table 7-8.	100-Pin PQFP Dimensions	7-10
Table A-1.	Serial Bill of Materials	A-4
Table A-2.	Parallel Billing Materials	A-9

勝特力材料 886-3-5753170
 勝特力电子(上海) 86-21-54151736
 勝特力电子(深圳) 86-755-83298787
[Http://www.100y.com.tw](http://www.100y.com.tw)

1.0 Functional Description

勝特力材料 886-3-5753170
勝特力电子(上海) 86-21-54151736
勝特力电子(深圳) 86-755-83298787
[Http://www.100y.com.tw](http://www.100y.com.tw)

1.1 Overview

The Conexant RC224ATLV is a combination V.22 bis data and Group 3 fax CMOS modem in a single VLSI package and is identical to the RC224ATLV. The RC224ATLV integrated data/fax modem is available in either a 68-pin plastic leaded chip carrier (PLCC) or a 100-pin plastic quad flat pack (PQFP).

Full error correction (V.42 LAPM, MNP2-4) and data compression (V.42 bis, MNP 5) capabilities can be supported in the RC224ATLV using the host communication software.

The modem has a selectable parallel or serial interface to the host data terminal equipment (DTE). When parallel mode is selected, a 16C450-compatible interface allows direct connection to a notebook, laptop, or PC-compatible bus without an external universal asynchronous receive/transmit (UART). When serial mode is selected, a CCITT V.24 logic-compatible interface with transistor to transistor logic (TTL) levels is supplied along with indicator outputs.

1.2 Technical Specifications

1.2.1 General

The RC224ATLV modem is a full-featured, self-contained data/fax solution. No external microcontroller for data or fax control functions is required. Dialing, call progress, and telephone line interface functions are fully supported and controlled through the AT command set.

Data modes perform complete handshake and data rate negotiations. All tone and pattern detection required by the applicable CCITT or Bell standard are supported.

Fax modes support Group 3 fax requirements. Fax data and fax control (V.21 300 bps), performed by the modem, are controlled and monitored through the fax EIA-578 Class 1 command interface. Full HDLC formatting, flag insertion/deletion, and CRC generation/checking is provided.

Both transmit and receive fax data is buffered within the modem. Fax data transfer to and from the DTE is flow controlled by X-on/X-off.

1.2.2 Configurations and Rates

The supported modem configurations and signaling rates are listed in [Table 1-1](#). In data modes with serial interface selected, DTE rate offsets of + 1%, – 2.5% are accommodated by adding/deleting stop bits as required. In fax modes, the DTE rate is 19,200 bps.

Table 1-1. Configurations and Rates

Configuration	Modulation	Transmitter Carrier Frequency (Hz) \pm 0.01%		Data Rate (bps)	Baud (Symbols/Sec.)	Bits Per Symbol	Constellation Points
Data Mode		Answer	Originate				
V.22 bis	QAM	2400	1200	2400	600	4	16
V.22	DPSK	2400	1200	1200	600	2	4
Bell 212A	DPSK	2400	1200	1200	600	2	4
Bell 103	FSK	2225 M 2025 S	1270 M 1070 S	300	300	1	1
Fax Mode		Receive	Transmit				
V.29	QAM	N/A	1700	9600	2400	4	16
	QAM	N/A	1700	7200	2400	3	8
V.27 ter	DPSK	1800	1800	4800	1600	3	8
	DPSK	1800	1800	2400	1200	2	4
V.21	FSK	1650 M 1850 S	1650 M 1850 S	300	300	1	1
Legend:							
QAM	Quadrature Amplitude Modulation						
DPSK	Differential Phase Shift Keying						
FSK	Frequency Shift Keying						
M	Mark condition						
S	Space Condition						
N/A	Not Applicable						

勝特力材料 886-3-5753170
 勝特力电子(上海) 86-21-54151736
 勝特力电子(深圳) 86-755-83298787
[Http://www.100y.com.tw](http://www.100y.com.tw)

1.2.3 Operation

Modem operation is controlled by AT commands, fax service class 1 commands, and supporting S registers.

1.2.3.1 Data Modes

Data rate selection is determined by the speed of the originating and answering modems, as defined in [Table 1-2](#).

Table 1-2. Data Rates vs. Connection Modem Rate

Originate Modem Rate (bps)	Connect Speed Based on Answer Modem Rate (bps)		
	300	1200	2400
300	300	300	300
1200	300	1200	1200
2400	300	1200	2400

1.2.3.2 Fax Modes

Fax modes are negotiated as defined in T.30 and are implemented by AT+F commands. The AT+FCLASS=1 command causes entry into the fax mode from the data mode. Most other fax class 1 commands, which start with the AT+F prefix, are valid only in the fax mode. All data commands are valid in the fax mode except A/, On, &Tn, and the escape sequence (+++). The AT+FCLASS=0 command terminates the fax mode and causes entry into the data mode.

1.2.4 Data/Fax Auto Answering

The modem can automatically determine if the incoming call is from a data or fax modem, make the appropriate connection, and inform the DTE of the connection type.

1.2.5 Data Modulation

The data modulation conforms to V.29, V.27 ter, V.22 bis, V.22, V.21, Bell 212A, or Bell 103, depending on the selected configuration. Transmitter and receiver spectrum shaping is provided in accordance with the applicable standard.

1.2.6 Equalization

Automatic adaptive equalization and fixed compromised equalization are provided to compensate for line distortions and to minimize the effects of intersymbol interference.

1.2.7 Scrambler/Descrambler

The modem incorporates a self-synchronizing scrambler/descrambler, which satisfies the applicable CCITT or Bell requirements.

1.2.8 Transmit Level

The transmit level is $-10 \text{ dBm} \pm 1 \text{ dB}$ (at TIP and RING) and can be obtained using the circuits shown in Appendix A. Carrier and dual tone multi-frequency (DTMF) transmit levels can be further attenuated using $\text{AT}\%L_n + \text{AT}\%D_n$ commands, respectively. If a higher transmit level is required, an external op amp can be added.

1.2.9 Transmit Tones

- Answer Tone** An answer tone of 2100 Hz (V.22 bis, V.22, or T.30) or 2225 Hz (Bell 212A or 103) is generated.
- Guard Tone** An 1800 Hz guard tone can be generated in all data modes.
- Calling Tone** An 1100 Hz (0.5 seconds on, 3 seconds off) calling tone (T.30) is generated in the originate fax mode.

1.2.10 Receive Level

The receiver satisfies performance requirements for a received signal from -9 dBm to -43 dBm . The carrier detect is ON at -43 dBm and OFF at -48 dBm with a minimum of 2 dB hysteresis.

1.2.11 Receiver Tracking

The modem can accommodate carrier frequency offset up to $\pm 7 \text{ Hz}$, and a transmit timing error of $\pm 0.01\%$ (V.22 bis or V.27 ter) or $\pm 0.02\%$ (V.22 or Bell 212A).

- DTMF Dialing** Standard DTMF tones (digits 0-9, A, B, C, D, *, and #) or pulses (digits 0-9) can be generated. Refer to [Table 1-3](#).
- Ring Detection** RING signal is detected from valid high to low transitions on the RING input line at frequencies of 15.3 Hz to 63 Hz. A RING is valid if the RING ON time is greater than 0.125 seconds and is followed by a RING OFF time greater than 0.5 seconds.

Table 1-3. Dial Digits/Tone Pairs (1 of 2)

Dial Digit	Tone 1 Frequency (Hz)	Tone 2 Frequency (Hz)
0	941	1336
1	697	1209
2	697	1336
3	697	1477
4	770	1209
5	770	1336

勝特力材料 886-3-5753170
 勝特力电子(上海) 86-21-54151736
 勝特力电子(深圳) 86-755-83298787
[Http://www.100y.com.tw](http://www.100y.com.tw)

Table 1-3. Dial Digits/Tone Pairs (2 of 2)

Dial Digit	Tone 1 Frequency (Hz)	Tone 2 Frequency (Hz)
6	770	1477
7	852	1209
8	852	1336
9	852	1477
*	941	1209
#	941	1477
A	697	1633
B	770	1633
C	852	1633
D	941	1633

1.2.12 Low Power Sleep Mode

To conserve power, the RC224ATLV has two selectable sleep (power-down) modes – Idle and Stop. If enabled by the IDLEN0 and IDLN1 inputs, the selective sleep mode is entered whenever the modem is active. The sleep mode indicator output, $\overline{\text{SLEEP}}$, is provided to allow external circuits to be powered down when the modem is in Idle or Stop mode.

The Idle mode allows reduced power consumption with automatic recovery without additional circuitry. If Idle mode is selected, the modem exits Idle mode and returns to full operation whenever a ring signal occurs, the DTE writes to the modem (parallel interface), or $\overline{\text{WAKEUP}}$ input, normally tied to $\overline{\text{DTR}}$ or $\overline{\text{TXD}}$, is asserted (serial interface).

The Stop mode further reduces power consumption, as defined in Table 1-4.

Table 1-4. Current and Power Requirements

Mode	Current (ID)		Power (PD)	
	Typical Current @ 25°C	Maximum Current @ 0°C	Typical Power @ 25°C	Maximum Power @ 0°C
Operating	21 mA	22 mA	100 mW	110 mW
Sleep–Idle	5 mA	6 mA	25 mW	30 mW
Sleep–Stop	1 mA	1 mA	5 mW	5 mW

NOTE(S):

1. Test conditions: VDD = 5.0 V_{DC} for typical values; VDD = 5.25 V_{DC} for maximum values.
2. Test conditions: VDD = 3.3 V_{DC} for typical values; VDD = 3.6 V_{DC} for maximum values.

Entry The modem will enter the low-power sleep mode when no line connection exists and no host activity occurs for the period of time specified in the S24 register. All EmbeddedModem circuits are turned off except the internal Microcontroller Unit (MCU) clock circuitry in order to consume lower power but are able to immediately wake up and resume normal operation.

Wake-up—Parallel Interface Configuration

Wake-up occurs when a ring signal occurs, or the host write to the modem.

Wake-up—Serial Interface Configuration

Wake-up occurs when a ring signal occurs, or the DTE sends a character to the modem.

勝特力材料 886-3-5753170
勝特力电子(上海) 86-21-54151736
勝特力电子(深圳) 86-755-83298787
[Http://www.100y.com.tw](http://www.100y.com.tw)

2.0 Hardware Interface

Figure 2-1 and Figure 2-2 illustrate the RC224ATLV hardware interface signals for the parallel and serial interfaces, respectively.

The RC224ATLV hardware interface signals are described in Table 3-5, *Hardware Interface Signal Definitions*.

See Table 7-2, *Timing-Host Bus Interface* for a list of the host bus interface timing parameters and Figure 7-1, *Timing Waveform* for an illustration of the interface waveforms.

勝特力材料 886-3-5753170
勝特力电子(上海) 86-21-54151736
勝特力电子(深圳) 86-755-83298787
[Http://www.100y.com.tw](http://www.100y.com.tw)

Figure 2-1. RC224ATLV Signals—Parallel Interface

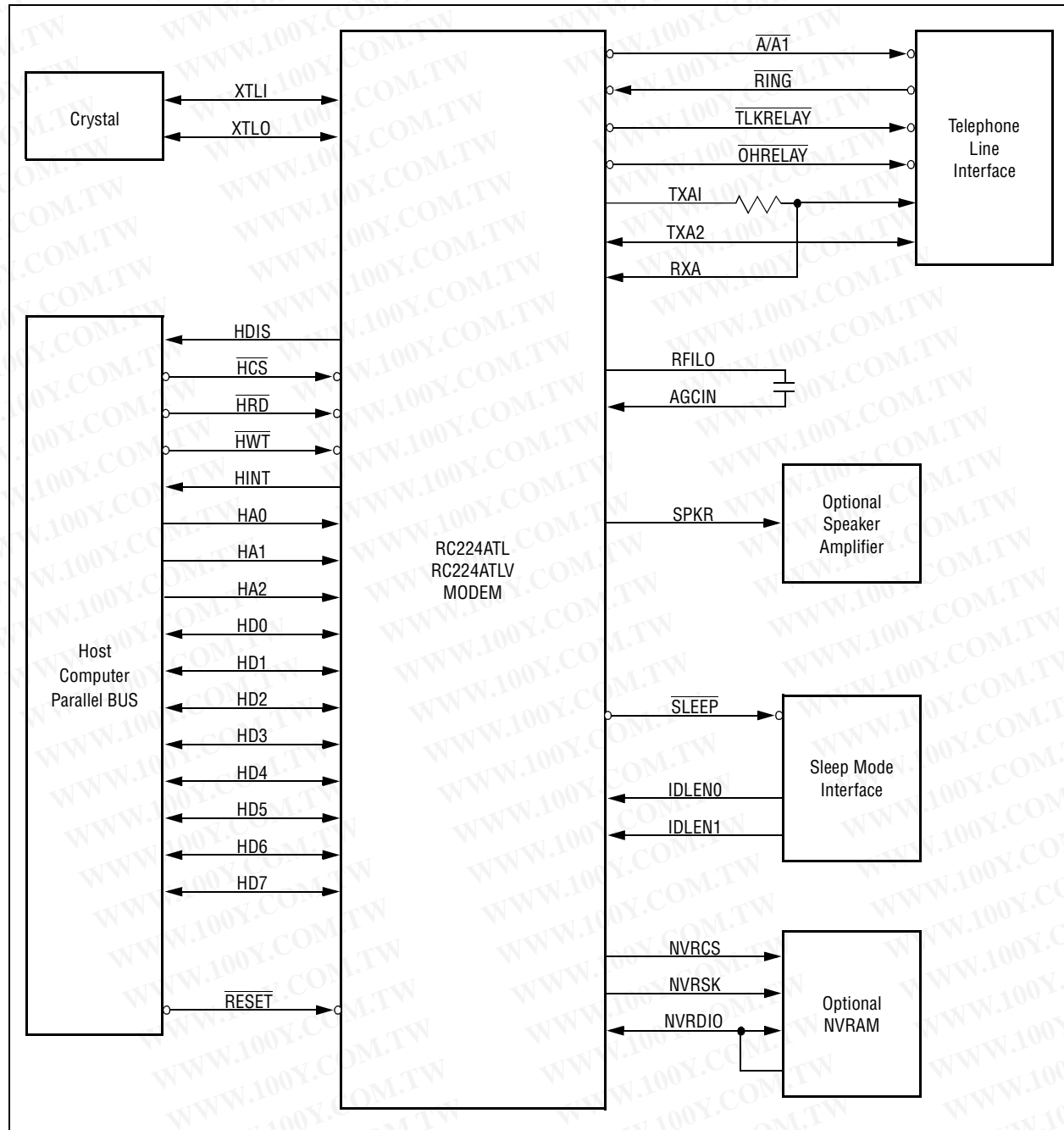

勝特力材料 886-3-5753170
 勝特力电子(上海) 86-21-54151736
 勝特力电子(深圳) 86-755-83298787
[Http://www.100y.com.tw](http://www.100y.com.tw)

Figure 2-2. RC224ATLV Signals—Serial Interface

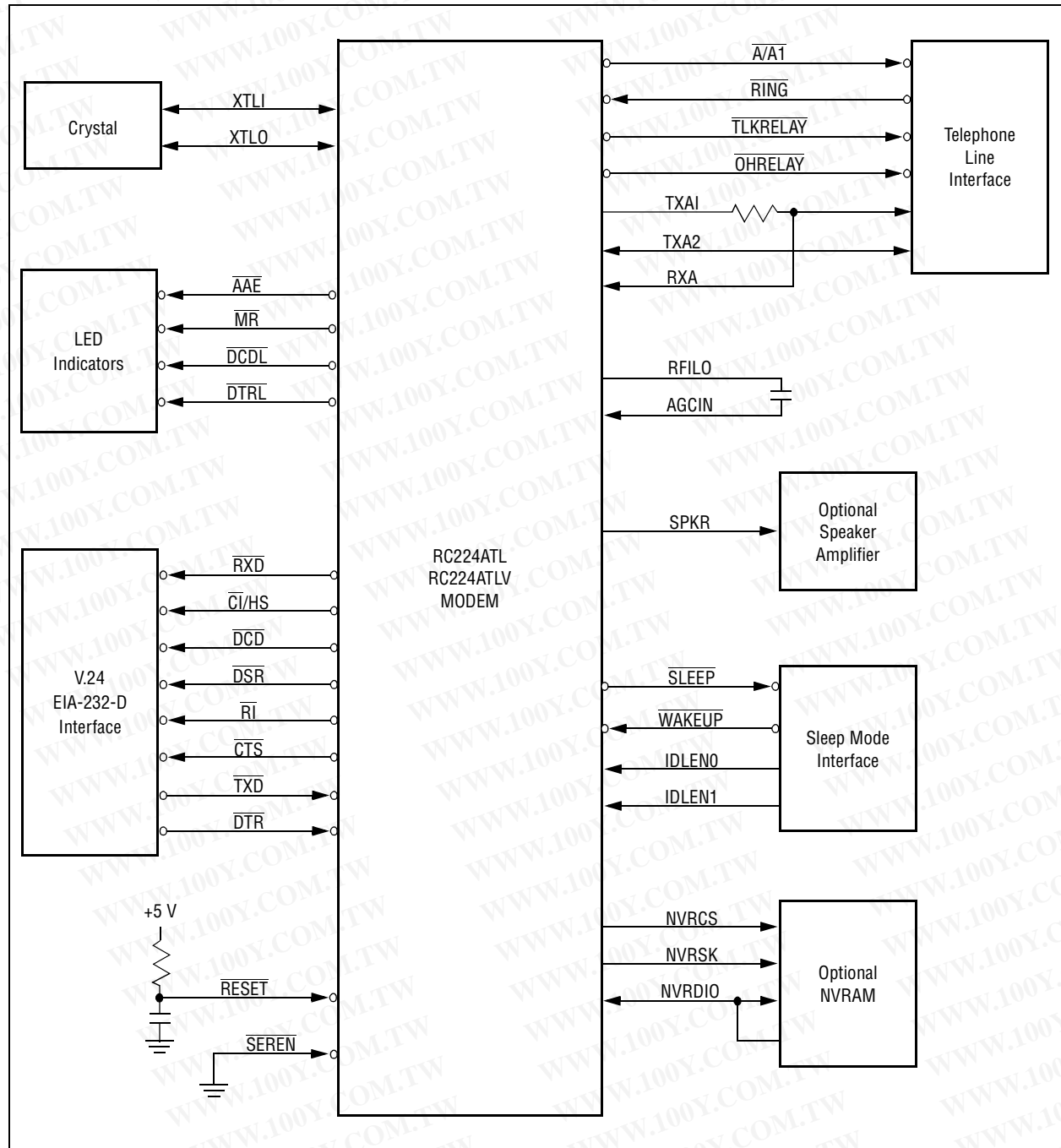

勝特力材料 886-3-5753170
 勝特力电子(上海) 86-21-54151736
 勝特力电子(深圳) 86-755-83298787
[Http://www.100y.com.tw](http://www.100y.com.tw)

The parallel interface registers are identified in [Table 2-1](#).

Table 2-1. Parallel Interface Registers (1 of 2)

Register Number	Register Name	Bit Number							
		7	6	5	4	3	2	1	0
7	Scratch Register (SCR)	Scratch Register							
6	Modem Status Register (MSR)	Data Carrier Detect (DCD)	Ring Indicator (RI)	Data Set Ready (DSR)	Clear to Send (CTS)	Delta Data Carrier Detect (DDCD)	Trailing Edge of Ring Indicator (TERI)	Delta Data Set Ready (DDSR)	Delta Clear to Send (DCTS)
5	Line Status Register (LSR)	0	Transmitter Empty (TEMT)	Transmitter Holding Register (THRE)	Break Interrupt (BI)	Framing Error (FE)	Parity Error (PE)	Overrun Error (OE)	Data Ready (DR)
4	Modem Control Register (MCR)	0	0	0	Local Loopback	Out 2	Out 1	Request to Send (RTS)	Data Terminal Ready (DTR)
3	Line Control Register (LCR)	Divisor Latch Access Bit (DLAB)	Set Break (SB)	Stick Parity (SP)	Even Parity Select (EPS)	Parity Enable (PEN)	Number of Stop Bits (STB)	Word Length Select Bit 1 (WLS1)	Word Length Select Bit 0 (WLS0)
2	Interrupt Identify Register (IIR) (Read Only)	0	0	0	0	0	Pending Interrupt ID Bit 1 (PL1)	Pending Interrupt ID Bit 0 (PLO)	0 if Interrupt Pending (IP)
1 DLAB = 0	Interrupt Enable Register (IER)	0	0	0	0	Enable Modem Status Interrupt (EDSSI)	Enable Receiver Line Status Interrupt (ELSI)	Enable Transmitter Holding Register Empty Interrupt (ETBEI)	Enable Received Data Available Interrupt (ERBFI)
0 DLAB = 0	Transmitter Holding Register (THR)	Transmitter Holding Register (Write Only)							
0 DLAB = 0	Receiver Buffer Register (RBR)	Receiver Buffer Register (Read Only)							

勝特力材料 86-3-5753170
 勝特力电子(上海) 86-21-54151736
 勝特力电子(深圳) 86-755-83298787
[Http://www.100y.com.tw](http://www.100y.com.tw)

Table 2-1. Parallel Interface Registers (2 of 2)

Register Number	Register Name	Bit Number							
		7	6	5	4	3	2	1	0
1 DLAB = 1	Divisor Latch MSB Register (DLM)	Divisor Latch (MS)							
0 DLAB = 1	Divisor Latch LSB Register (DLL)	Divisor Latch (LS)							

勝特力材料 886-3-5753170
 勝特力电子(上海) 86-21-54151736
 勝特力电子(深圳) 86-755-83298787
[Http://www.100y.com.tw](http://www.100y.com.tw)

2.1 Hardware Interface

2.1.1 Parallel Interface

A 16450 UART-compatible parallel interface is provided.

Host Bus Interface

Eight data lines, three address lines, and four control lines are supported.

Interrupt Enable Register (Addr=1, DLAB=0)

The Interrupt Enable Register (IER) enables four types of interrupts that can separately assert the HINT output. A selected interrupt can be enabled by setting the corresponding enable bit to a logic 1, or disabled by resetting the corresponding enable bit to a logic 0. All interrupt sources are disabled by setting bits 0–3 to a logic 0. Disabling all interrupts inhibits the Interrupt Identifier Register (IIR) and inhibits assertion of the HINT output. All other system functions operate normally, including the setting of the Line Status Register (LSR) and the Modem Status Register (MSR).

7	6	5	4	3	2	1	0
0	0	0	0	EDSSI	ELSI	ETBEI	ERBFI

Bits 4-7: Not used (always logic 0).

EDSSI

Enable Modem Status Interrupt. When this bit is a logic 1, it enables assertion of the HINT output whenever bit 0, 1, 2, or 3 in the Modem Status Register (MSR) is a logic 1. When this bit is a logic 0, it disables assertion of HINT due to setting of any of these four MSR bits.

ELSI

Enable Receiver Line Status Interrupt. When this bit is a logic 1, it enables assertion of the HINT output when any receiver status bit in the Line Status Register (LSR); i.e., bits 1, 2, 3, or 4, changes state. When this bit is a logic 0, it disables assertion of HINT due to change of the receiver LSR bits.

ETBEI

Enable Transmitter Holding Register Empty Interrupt. When this bit is a logic 1, it enables assertion of the HINT output when the Transmitter Holding Register Empty (THRE) bit in the Line Status Register (LSR5) is set to a logic 1. When this bit is a logic 0, it disables assertion of HINT due to LSR5.

ERBFI

Enable Received Data Available Interrupt. When this bit is a logic 1, it enables assertion of the HINT output when received data is available in the Receiver Buffer; i.e., the Data Ready bit in the Line Status Register (LSR0) is a logic 1. When this bit is a logic 0, it disables assertion of HINT due to the LSR0.

勝特力材料 886-3-5753170
 勝特力电子(上海) 86-21-54151736
 勝特力电子(深圳) 86-755-83298787
[Http://www.100y.com.tw](http://www.100y.com.tw)

Interrupt Identifier Register (Addr = 2)

The Interrupt Identifier Register (IIR) identifies the existence and type of prioritized pending interrupts. Four priority levels are set to assist interrupt processing in the host.

When addressed during chip-select time, the IIR freezes the highest priority interrupt pending and acknowledges no other interrupts until the particular interrupt is serviced by the host.

7	6	5	4	3	2	1	0
0	0	0	0	0	PL1	PL0	IP

Bits 3-7: Not used (always 0).

PL0-1

Highest Priority Pending Interrupt. These two bits identify the highest priority pending interrupt.

2	1	Priority Level	Pending Interrupt
1	1	(highest)	Receiver Line Status
1	0	2	Receiver Buffer Full
0	1	3	Transmitter Holding Register Empty
0	0	4	Modem Status

IP

Interrupt Pending. When this bit is a logic 0, an interrupt is pending. When this bit is a logic 1, no interrupt is pending. This bit can be used in a hardwired prioritized or polled environment to indicate whether an interrupt is pending. If an interrupt is pending, the IIR contents can be used as a pointer to the appropriate interrupt service routine in the host.

勝特力材料 886-3-5753170
 勝特力电子(上海) 86-21-54151736
 勝特力电子(深圳) 86-755-83298787
[Http://www.100y.com.tw](http://www.100y.com.tw)

**Line Control Register
(Addr = 3)**

The Line Control Register (LCR) specifies the format of the asynchronous data communications exchange.

7	6	5	4	3	2	1	0
DLAB	SB	SP	EPS	PEN	STB	WLS1	WLS0

DLAB

Divisor Latch Access Bit. This bit must be set to a logic 1 to access the Divisor latches of the baud generator during a read or write operation. It must be reset to a logic 0 to access the Receiver Buffer, the Transmitter Holding Register, or the Interrupt Enable Register.

SB

Set Break. When this bit is set to a logic 1, the transmit data is forced to the space (logic 0) state. The break is disabled by setting this bit to a logic 0. The Set Break bit acts only on the transmit data and has no effect on the serial in logic.

SP

Stick Parity. When stick parity is selected (LCR5 = 1), parity is enabled (LCR3 = 1), and even parity is selected (LCR4 = 1), the parity bit is transmitted and checked by the receiver as a logic 0. When stick parity is selected (LCR5 = 1), parity is enabled (LCR3 = 1), and odd parity is selected (LCR4 = 0), the parity bit is transmitted and checked by the receiver as a logic 1.

EPS

Even Parity Select. When parity is enabled (LCR3 = 1), and Stick Parity (LCR5) is a logic 0, the number of logic 1s transmitted or checked in the data word bits and parity bit is either even (LCR4 = 1) or odd (LCR4 = 0).

PEN

Parity Enable. When bit 3 is a logic 1, a parity bit is generated in the serial out (transmit) data stream and checked in the serial in (receive) data stream. The parity bit is located between the last data bit and the first stop bit.

STB

Number of Stop Bits. This bit specifies the number of stop bits in each serial out character. If bit 2 is a logic 0, one stop bit is generated regardless of word length. If bit 2 is a logic 1 when either a 5-, 6-, 7-, or 8-bit word length is selected, two stop bits are generated. The serial in logic checks the first stop bit only regardless of the number of stop bits selected.

WLS0 and WLS1 Word Length Select. These two bits specify the number of bits in each serial in or serial out character. The encoding of bits 0 and 1 is:

Bit 1	Bit 0	Word Length
0	0	5 Bits
0	1	6 Bits
1	0	7 Bits
1	1	8 Bits

勝特力材料 886-3-5753170
 勝特力电子(上海) 86-21-54151736
 勝特力电子(深圳) 86-755-83298787
[Http://www.100y.com.tw](http://www.100y.com.tw)

**Modem Control Register
(Addr = 4)**

The Modem Control Register (MCR) controls the interface with the modem or data set.

7	6	5	4	3	2	1	0
0	0	0	LL	OUT2	OUT1	RTS	DTR

Bit 5-7: Not used (always 0).

LL

Local Loopback. When this bit is set to a logic 1, the diagnostic mode is selected and the following occurs:

1. Data written to the Transmit Holding Register will be looped back to the Receiver Buffer Register.
2. The four modem control bits (CTS, DSR, RI, and DCD) are internally connected to the four modem control outputs (RTS, DTR, OUT1, and OUT2), respectively.

OUT2

Output 2. When this bit is a logic 1, HINT is enabled. When this bit is a logic 0, HINT is in the high impedance state.

OUT1

Output 1. This bit is used in local loopback (see MCR4).

RTS

Request to Send. This bit controls the Request to Send (RTS) function. When this bit is a logic 1, RTS is on. When this bit is a logic 0, RTS is off.

DTR

Data Terminal Ready. This bit controls the Data Terminal Ready (DTR) function. When this bit is a logic 1, DTR is on. When this bit is a logic 0, DTR is off.

勝特力材料 886-3-5753170
 勝特力电子(上海) 86-21-54151736
 勝特力电子(深圳) 86-755-83298787
[Http://www.100y.com.tw](http://www.100y.com.tw)

**Line Status Register
(Addr = 5)**

The LSR, an 8-bit register, provides status information to the host concerning data transfer.

7	6	5	4	3	2	1	0
0	TEMT	THRE	BI	FE	PE	OE	DR

Bit 7: This bit is set to logic 0.

TEMT **Transmitter Empty.** This bit is set to a logic 1 whenever the Transmitter Holding Register (THR) and the Transmitter Shift Register (TSR) are both empty. It is reset to a logic 0 whenever either the THR or TSR contains a data character.

THRE **Transmitter Holding Register Empty.** This bit indicates that the modem is ready to accept a new character for transmission. In addition, this bit causes the modem to issue an interrupt to the host when the Transmit Holding Register Empty Interrupt Enable bit (IIR1) is set to logic 1. The THRE bit is set to a logic 1 when a character is transferred from the Transmitter Holding Register into the Transmitter Shift Register. The bit is reset to logic 0 concurrently with the loading of the Transmitter Holding Register by the host.

BI **Break Interrupt.** This bit is set to a logic 1 whenever the received data input is a space (logic 0) for longer than two full word lengths plus 3 bits. The 81 indicator is reset whenever the host reads the LSR.

FE **Framing Error.** This bit indicates that the received character did not have a valid stop bit. Bit 3 is set to a logic 1 whenever the stop bit following the last data bit or parity bit is detected as a zero bit. The FE bit is reset to a logic 0 whenever the host reads the LSR.

PE **Parity Error.** This bit indicates that the received data character does not have the correct even or odd parity, as selected by the Even Parity Select bit (LCR4) and the Stick Parity bit (LCR5). The PE bit is set to a logic 1 upon detection of parity error and is reset to a logic 0 whenever the host reads the LSR.

OE **Overrun Error.** This bit indicates that data in the Receiver Buffer Register was not read by the host before the next character was transferred into the Receiver Buffer Register, thereby destroying the previous character. The OE bit is reset whenever the host reads the LSR.

DR **Data Ready.** This bit is set to a logic 1 whenever a complete incoming character has been received and transferred into the Receiver Buffer Register. Bit 0 is reset to a logic 0 when the host reads the Receiver Buffer Register.

勝特力材料 886-3-5753170
 勝特力电子(上海) 86-21-54151736
 勝特力电子(深圳) 86-755-83298787
[Http://www.100y.com.tw](http://www.100y.com.tw)

**Modem Status Register
(Addr = 6)**

The Modem Status Register (MSR) reports the modem's current state and change information. Bits 4-7 supply current state, and bits 0-3 supply change information. The change bits are set to a logic 1 whenever a control input from the modem changes state from the last MSR read by the host. Bits 0-3 are reset to logic 0 when the host reads the MSR or upon reset.

Whenever Bits 0, 1, 2, or 3 are set to a logic 1, a Modem Status Interrupt is generated.

7	6	5	4	3	2	1	0
DCD	RI	DSR	CTS	DDCD	TERI	DDSR	DCTS

DCD **Data Carrier Detect.** This bit indicates the logic state of the DCD output. If Loopback is selected (MCR4 = 1), this bit reflects the state of OUT2 in the MCR (MCR3).

RI **Ring Indicator.** This bit indicates the logic state of the RI output. If Loopback is selected (MCR4 = 1), this bit reflects the state of OUT1 in the MCR (MCR2).

DSR **Data Set Ready.** This bit indicates the logic state of the DSR output. If Loopback is selected (MCR4 = 1), this bit reflects the state of DTR in the MCR (MCR0).

CTS **Clear to Send.** This bit indicates the logic state of the CTS output. If Loopback is selected (MCR4 = 1), this bit reflects the state of RTS in the MCR (MCR1).

DDCD **Delta Data Carrier Detect.** This bit is set to a logic 1 when the DCD bit has changed since the MSR was last read by the host.

TERI **Trailing Edge of Ring Indicator.** This bit is set to a logic 1 when the RI bit changes from a 1 to a 0 state since the MSR was last read by the host.

DDSR **Delta Data Set Ready.** This bit is set to a logic 1 when the DSR bit has changed state since the MSR was last read by the host.

DCTS **Delta Clear to Send.** This bit is set to a logic 1 when the CTS bit has changed state since the MSR was last read by the host.

**Receiver Buffer Register
(Addr=0, DLAB=0)**

The Receiver Buffer Register (RBR) is a read-only register at location 0 (with DLAB = 0). Bit 0 is the least significant bit of the data, and is the first bit received.

**Transmitter Holding Register
(Addr=0, DLAB=0)**

The Transmitter Holding Register (THR) is a write-only register at address 0 when DLAB = 0. Bit 0 is the least significant bit and the first bit sent.

勝特力材料 886-3-5753170
 勝特力电子(上海) 86-21-54151736
 勝特力电子(深圳) 86-755-83298787
[Http://www.100y.com.tw](http://www.100y.com.tw)

**Divisor Registers
(Addr=0 and 1, DLAB=1)**

The Divisor Latch LS Byte and Divisor Latch MS Byte are two read-write registers at locations 0 and 1 when DLAB = 1, respectively.

The baud rate is selected by loading each divisor latch with the appropriate hex value. Table 2-2 lists the programmable values corresponding to the desired baud rate.

Table 2-2. Programmable Baud Rates

Divisor Latch (Hex)		Divisor (Decimal)	Baud Rate
MS	LS		
01	80	384	300
00	C0	192	600
00	60	96	1200
00	30	48	2400

勝特力材料 886-3-5753170
 勝特力电子(上海) 86-21-54151736
 勝特力电子(深圳) 86-755-83298787
[Http://www.100y.com.tw](http://www.100y.com.tw)

**Scratch Register (SCR)
(Addr = 7)**

The Scratchpad Register is a read-write register at location 7. This register is not used by the DSP and can be used by the host for temporary storage.

2.1.2 Serial/Indicator Interface

A DTE serial interface and indicator outputs are supported.

- Serial Interface: An 8-line V.24/EIA-232-D or TTL logic serial interface to the DTE is supported.
- LED Indicator Interface: Four direct connect LED indicator outputs are supported.

2.1.3 Speaker Interface

A speaker output, controlled by AT or V.25 bis commands, is provided for an optional OEM-supplied speaker circuit.

2.1.4 Line Interface

The EmbeddedModem connects to the line interface circuitry by means of a receive analog input, two transmit analog outputs, and a ring signal input.

The EmbeddedModem provides three relay control outputs to the line interface. These outputs may be used to control relays such as off-hook, $\overline{A/A1}$, and talk/data.

2.2 Additional Information

Additional information is provided in the RC224ATLV *Modem Designer's Guide* (Order No. 821).

3.0 Pin Descriptions

The RC224ATLV 68-pin PLCC serial and parallel pinouts are displayed in [Figure 3-1](#) and [Figure 3-2](#), respectively. The 100-pin PQFP serial and parallel pinout diagrams are displayed in [Figure 3-3](#) and [Figure 3-4](#), respectively. [Figure 3-5](#) displays NVRAM timing.

RC224ATLV 68-pin PLCC serial and parallel pin assignments are displayed in [Table 3-1](#) and [Table 3-2](#), respectively. The 100-pin serial and parallel pin assignments are displayed in [Table 3-3](#) and [Table 3-4](#), respectively.

Figure 3-1. 68-Pin PLCC Package—Serial

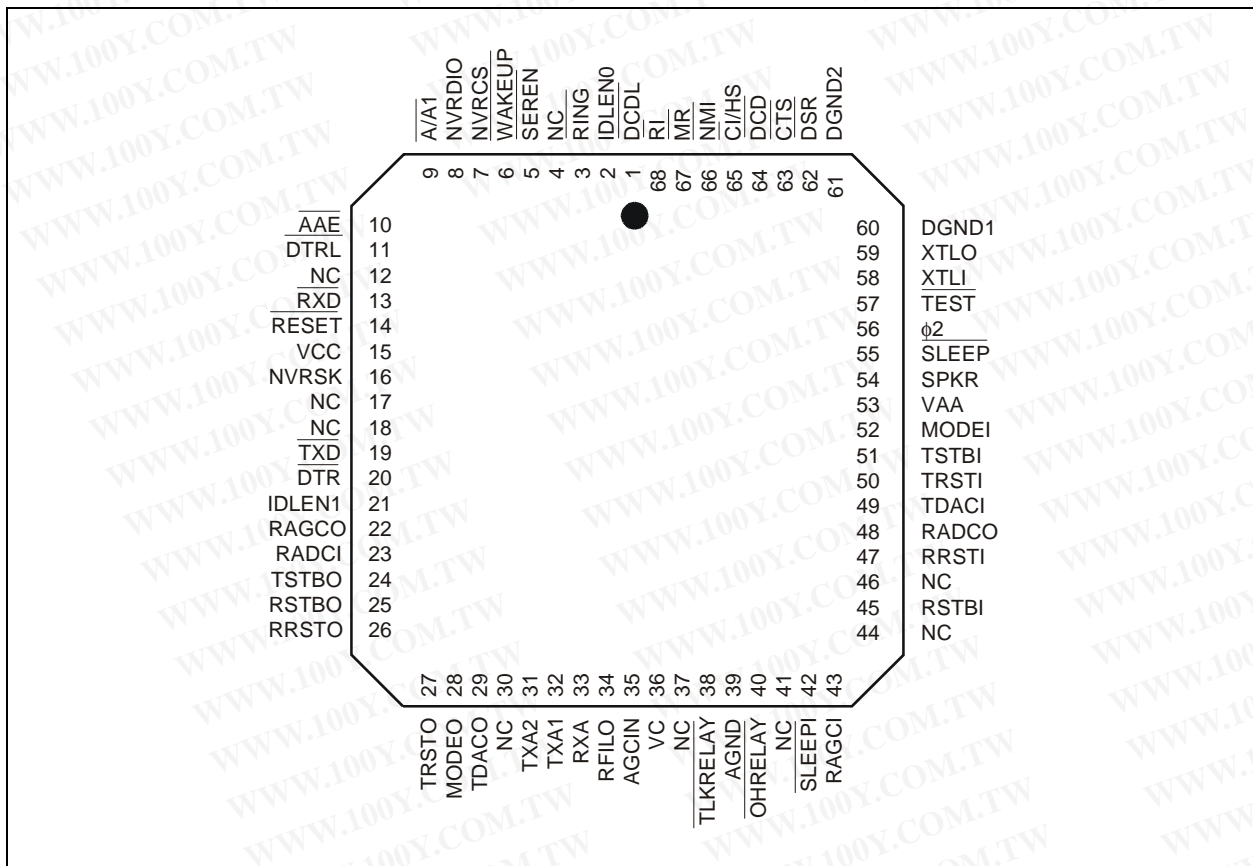
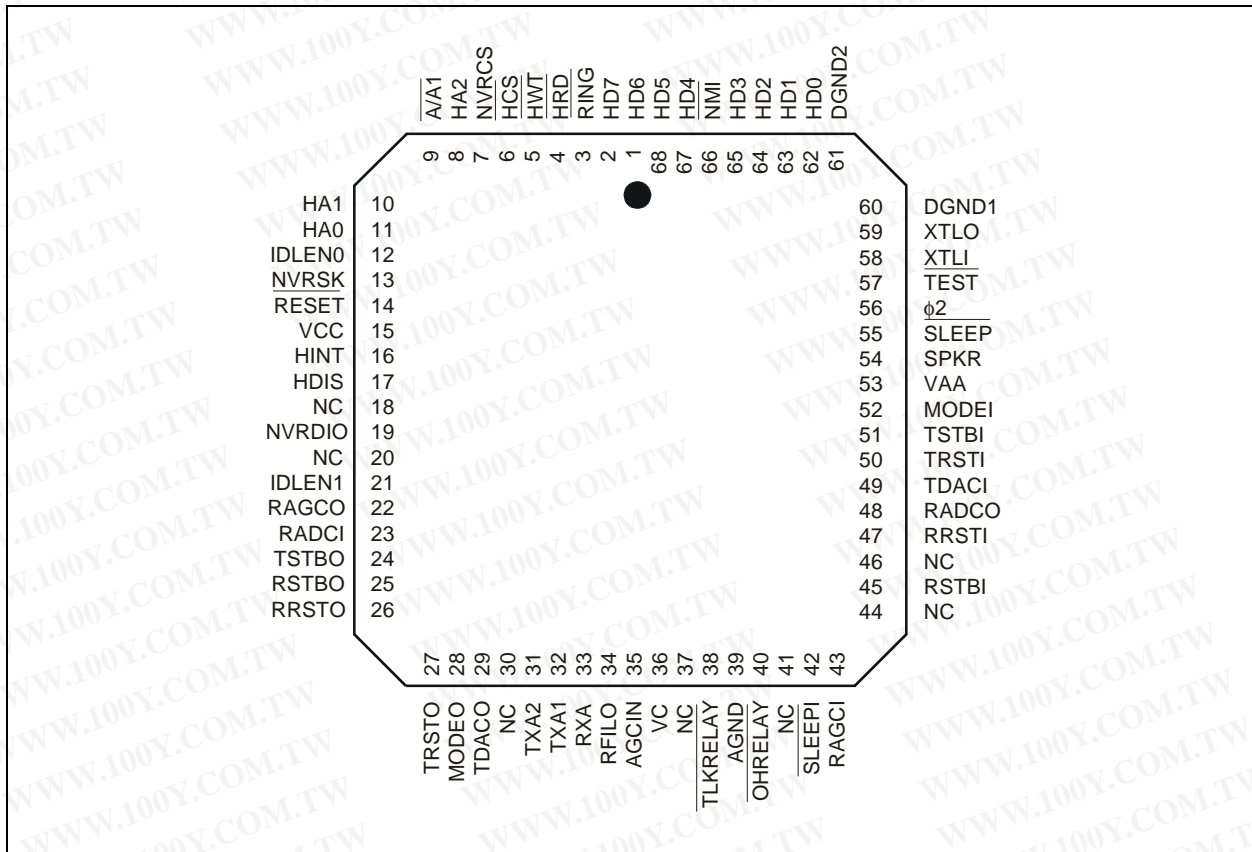
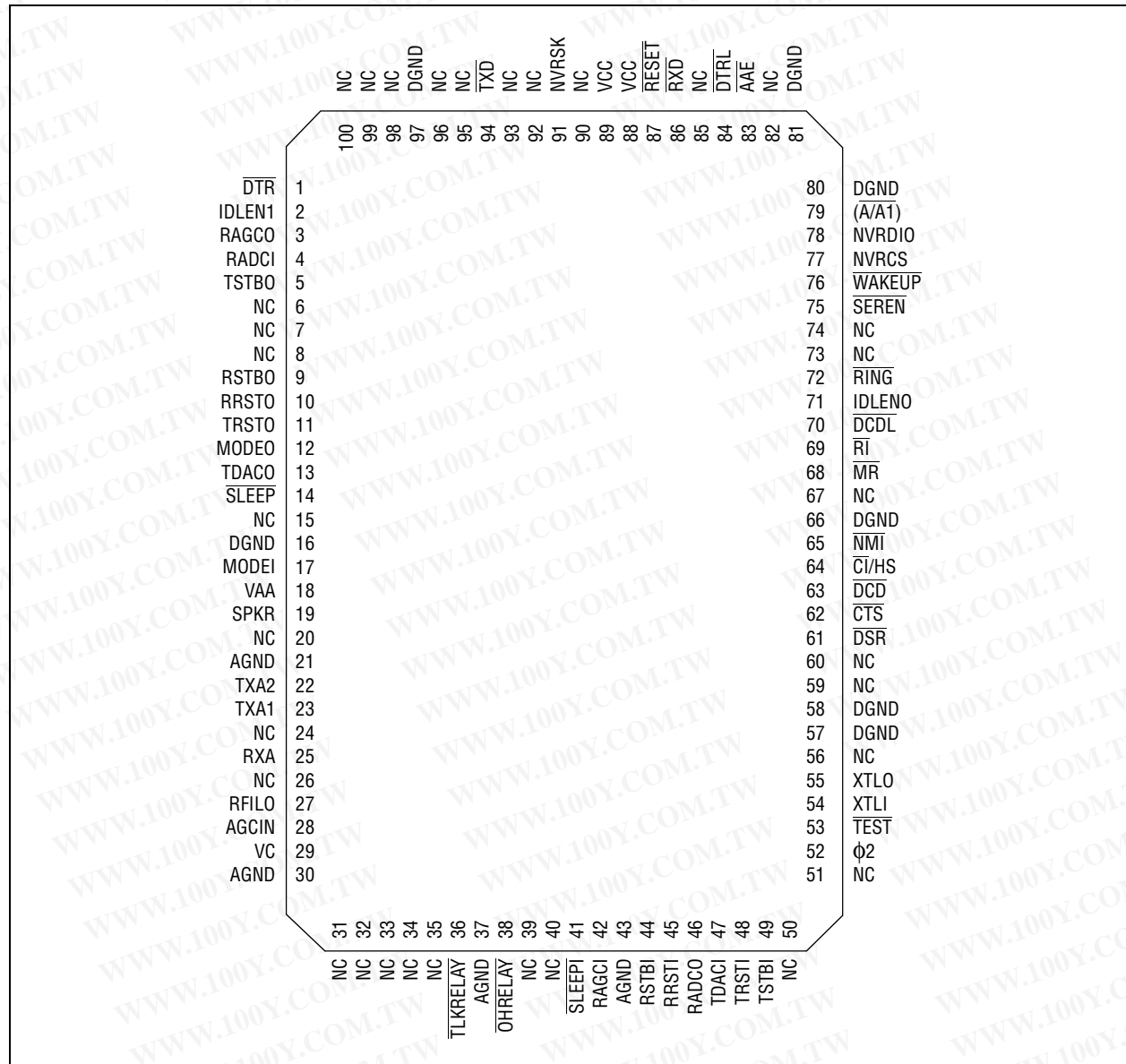

Figure 3-2. 68-Pin PLCC Package—Parallel



勝特力材料 886-3-5753170
 勝特力电子(上海) 86-21-54151736
 勝特力电子(深圳) 86-755-83298787
[Http://www.100y.com.tw](http://www.100y.com.tw)

Figure 3-3. 100-Pin PQFP Package—Serial



勝特力材料 886-3-5753170
 勝特力电子(上海) 86-21-54151736
 勝特力电子(深圳) 86-755-83298787
[Http://www.100y.com.tw](http://www.100y.com.tw)

Figure 3-4. 100-Pin PQFP Package—Parallel

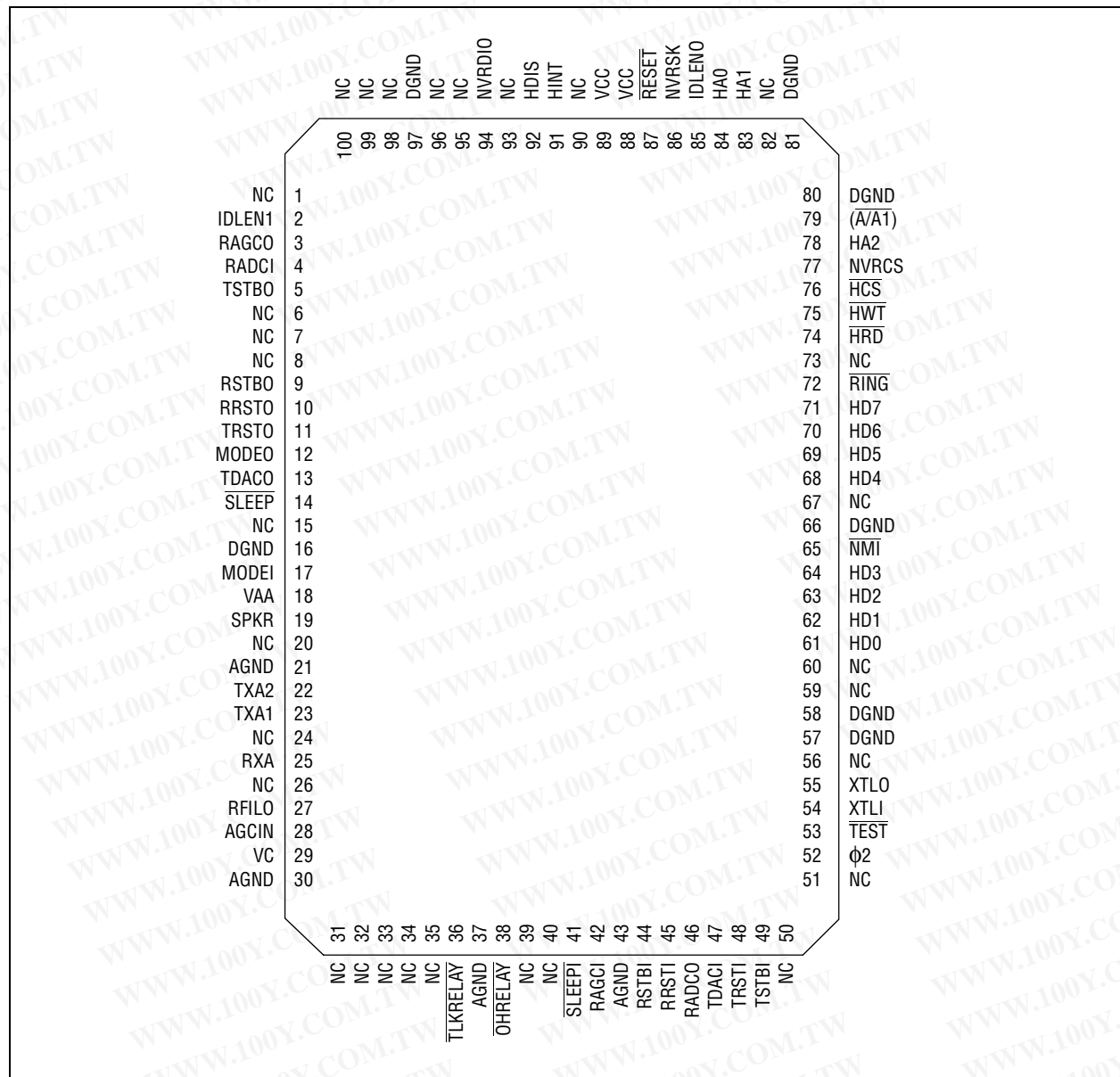

勝特力材料 886-3-5753170
 勝特力电子(上海) 86-21-54151736
 勝特力电子(深圳) 86-755-83298787
[Http://www.100y.com.tw](http://www.100y.com.tw)

Table 3-1. RC224ATL/224ATLV 68-Pin PLCC Pin Assignments—Serial Mode

Pin Number	Signal Label	I/O Type	Pin Number	Signal Label	I/O Type
1	$\overline{\text{DCDL}}$	DO	35	AGCIN	—
2	IDLENO	DI	36	VC	—
3	$\overline{\text{RING}}$	DI	37	NC	—
4	NC	—	38	$\overline{\text{TLKRELAY}}$	OD
5	$\overline{\text{SEREN}}$	DI	39	AGND	—
6	$\overline{\text{WAKEUP}}$	DI	40	$\overline{\text{OHRELAY}}$	OD
7	NVRCS	DO	41	NC	—
8	NVRDIO	DI	42	$\overline{\text{SLEEP1}}$	DI
9	$\overline{\text{A/A1}}$	DO	43	RAGCI	MI TO RAGCO
10	$\overline{\text{AAE}}$	DO	44	NC	—
11	$\overline{\text{DTRL}}$	DO	45	RSTBI	MI TO RSTBO
12	NC	—	46	NC	—
13	$\overline{\text{RXD}}$	DO	47	RRSTI	MI TO RRSTO
14	$\overline{\text{RESET}}$	DI	48	RADCO	RADCO
15	VCC	—	49	TDACI	MI TO TADCO
16	NVRSK	DO	50	TRSTI	MI TO TRSTO
17	NC	—	51	TSTBI	MI TO TSTBO
18	NC	—	52	MODEI	MI TO MODEO
19	$\overline{\text{TXD}}$	DI	53	VAA	—
20	$\overline{\text{DTR}}$	DI	54	SPKR	O(DF)
21	IDLEN1	DI	55	$\overline{\text{SLEEP}}$	DO
22	RAGCO	MI TO RAGCI	56	$\phi 2$	DO
23	RADCI	MI TO RADCO	57	$\overline{\text{TEST}}$	DI 4.7K TO VCC
24	TSTBO	MI TO TSTBI	58	XTLI	IE
25	RSTBO	MI TO RSTBI	59	XTLO	OE
26	RRSTO	MI TO RRSTI	60	DGND1	—
27	TRSTO	MI TO TRSTI	61	DGND2	—
28	MODEO	MI TO MODEI	62	$\overline{\text{DSR}}$	DO
29	TDACO	MI TO TDACI	63	$\overline{\text{CTS}}$	DO
30	NC	—	64	$\overline{\text{DCD}}$	DO
31	TXA2	O (DD)	65	$\overline{\text{CI/HS}}$	DO
32	TXA1	O(DD)	66	$\overline{\text{NMI}}$	DI
33	RXA	I(DA)	67	$\overline{\text{MR}}$	DO
34	RFILO	—	68	$\overline{\text{RI}}$	DO

Table 3-2. RC224ATLV 68-Pin PLCC Pin Assignments—Parallel Mode

Pin Number	Signal Label	I/O Type	Pin Number	Signal Label	I/O Type
1	HD6	DIO	35	AGCIN	—
2	HD7	DIO	36	VC	—
3	RING	DI	37	NC	—
4	HRD	DI	38	TLKRELAY	OD
5	HWT	DI	39	AGND	—
6	HCS	DI	40	OHRELAY	OD
7	NVRCS	DO	41	NC	—
8	HA2	DI	42	SLEEP1	DI
9	A/A1	DO	43	RAGCI	MI TO RAGCO
10	HA1	DI	44	NC	—
11	HA0	DI	45	RSTBI	MI TO RSTBO
12	IDLENO	—	46	NC	—
13	NVRSK	DO	47	RRSTI	MI TO RRSTO
14	RESET	DI	48	RADCO	RADCO
15	VCC	—	49	TDACI	MI TO TADCO
16	HINT	DO	50	TRSTI	MI TO TRSTO
17	HDIS	DO	51	TSTBI	MI TO TSTBO
18	NC	—	52	MODEI	MI TO MODEO
19	NVRDIO	DIO	53	VAA	—
20	NC	—	54	SPKR	O(DF)
21	IDLEN1	DI	55	SLEEP	OA
22	RAGCO	MI TO RAGCI	56	φ2	OA
23	RADCI	MI TO RADCO	57	TEST	4.7k TO VCC
24	TSTBO	MI TO TSTBI	58	XTLI	IE
25	RSTBO	MI TO RSTBI	59	XTLO	OE
26	RRSTO	MI TO RRSTI	60	DGND1	—
27	TRSTO	MI TO TRSTI	61	DGND2	—
28	MODEO	MI TO MODEI	62	HD0	DIO
29	TDACO	MI TO TDACI	63	HD1	DIO
30	NC	—	64	HD2	DIO
31	TXA2	O (DD)	65	HD3	DIO
32	TXA1	O(DD)	66	NMI	DI
33	RXA	I(DA)	67	HD4	DIO
34	RFILO	—	68	HD5	DIO

Table 3-3. RC224ATL/224ATLV 100-Pin PQFP Pin Assignments—Serial (1 of 4)

Pin Number	Signal Label	I/O Type ⁽¹⁾
1	$\overline{\text{DTR}}$	DI
2	IDLEN1	DI
3	RAGCO	MI ⁽²⁾ to RAGCI
4	RADCI	MI to RADCO
5	TSTBO	MI to TSTBI
6	NC ⁽³⁾	—
7	NC	—
8	NC	—
9	RSTBO	MI to RSTBI
10	RRSTO	MI to RRSTI
11	TRSTO	MI to TRSTI
12	MODEO	MI to MODEI
13	TDACO	MI to TDACI
14	$\overline{\text{SLEEP}}$	DO
15	NC	—
16	DGND	DGND ⁽⁴⁾
17	MODEI	MI to MODEO
18	VAA	—
19	SPKR	O(DF)
20	NC	—
21	AGND	AGND
22	TXA2	O(DD)
23	TXA1	O(DD)
24	NC	—
25	RXA	I(DA)
26	NC	—
27	RFILO	—

NOTE(S):

- (1) I/O Types are described in [Figure 7-5, Digital Interface Characteristics](#) and [Figure 7-6, Analog Interface Characteristics](#).
- (2) MI = Modem Interconnection
- (3) NC = No external connection (may have internal connection, leave pin disconnected (open)).
- (4) AGND is analog ground and DGND is digital ground.
- (5) Connect to VCC through 4.7 k Ω .
- (6) Connect ATL to +5 VCC, ATLV to +3 VCC.

勝特力材料 886-3-5753170
 勝特力电子(上海) 86-21-54151736
 勝特力电子(深圳) 86-755-83298787
 Http://www.100y.com.tw

Table 3-3. RC224ATL/224ATLV 100-Pin PQFP Pin Assignments—Serial (2 of 4)

Pin Number	Signal Label	I/O Type ⁽¹⁾
28	AGCIN	—
29	VC	—
30	AGND	AGND
31	NC	—
32	NC	—
33	NC	—
34	NC	—
35	NC	—
36	$\overline{\text{TLKRELAY}}$	OD
37	AGND	AGND
38	$\overline{\text{OHRELAY}}$	OD
39	NC	—
40	NC	—
41	$\overline{\text{SLEEP1}}$	DI
42	RAGCI	MI to RAGCO
43	AGND	AGND
44	RSTBI	MI to RSTBO
45	RRSTI	MI to RRSTO
46	RADCO	MI to RADCI
47	TDACI	MI to TDACO
48	TRSTI	MI to TRSTO
49	TSTBI	MI to TSTBO
50	NC	—
51	NC	—
52	$\phi 2$	DO
53	$\overline{\text{TEST}}$	⁽⁵⁾
54	XTLI	IE

NOTE(S):

- (1) I/O Types are described in [Figure 7-5, Digital Interface Characteristics](#) and [Figure 7-6, Analog Interface Characteristics](#).
- (2) MI = Modem Interconnection
- (3) NC = No external connection (may have internal connection, leave pin disconnected (open)).
- (4) AGND is analog ground and DGND is digital ground.
- (5) Connect to VCC through 4.7 k Ω .
- (6) Connect ATL to + 5 VCC, ATLV to + 3 VCC.

勝特力材料 886-3-5753170
 勝特力电子(上海) 86-21-54151736
 勝特力电子(深圳) 86-755-83298787
 Http://www.100y.com.tw

Table 3-3. RC224ATL/224ATLV 100-Pin PQFP Pin Assignments—Serial (3 of 4)

Pin Number	Signal Label	I/O Type ⁽¹⁾
55	XTLO	OE
56	NC	—
57	DGND	DGND
58	DGND	DGND
59	NC	—
60	NC	—
61	$\overline{\text{DSR}}$	DO
62	$\overline{\text{CTS}}$	DO
63	$\overline{\text{DCD}}$	DO
64	$\overline{\text{CI/HS}}$	DO
65	$\overline{\text{NMI}}$	(6)
66	DGND	DGND
67	NC	—
68	$\overline{\text{MR}}$	DO
69	$\overline{\text{RT}}$	DO
70	$\overline{\text{DCDL}}$	DO
71	IDLENO	DI
72	$\overline{\text{RING}}$	DI
73	NC	—
74	NC	—
75	$\overline{\text{SEREN}}$	DI
76	$\overline{\text{WAKEUP}}$	DI
77	NVRCS	DO
78	NVRDIO	DIO
79	$\overline{\text{(A/A1)}}$	DO
80	DGND	DGND
81	DGND	DGND

NOTE(S):

- (1) I/O Types are described in [Figure 7-5, Digital Interface Characteristics](#) and [Figure 7-6, Analog Interface Characteristics](#).
- (2) MI = Modem Interconnection
- (3) NC = No external connection (may have internal connection, leave pin disconnected (open)).
- (4) AGND is analog ground and DGND is digital ground.
- (5) Connect to VCC through 4.7 k Ω .
- (6) Connect ATL to +5 VCC, ATLV to +3 VCC.

勝特力材料 886-3-5753170
 勝特力电子(上海) 86-21-54151736
 勝特力电子(深圳) 86-755-83298787
 Http://www.100y.com.tw

Table 3-3. RC224ATL/224ATLV 100-Pin PQFP Pin Assignments—Serial (4 of 4)

Pin Number	Signal Label	I/O Type ⁽¹⁾
82	NC	—
83	$\overline{\text{AAE}}$	DO
84	$\overline{\text{DTRL}}$	DO
85	NC	—
86	$\overline{\text{RXD}}$	DO
87	$\overline{\text{RESET}}$	IC
88	VCC	(6)
89	VCC	(6)
90	NC	—
91	NVRSK	DO
92	NC	—
93	NC	—
94	$\overline{\text{TXD}}$	DI
95	NC	—
96	NC	—
97	DGND	DGND
98	NC	—
99	NC	—
100	NC	—

NOTE(S):

- (1) I/O Types are described in Figure 7-5, *Digital Interface Characteristics* and Figure 7-6, *Analog Interface Characteristics*.
- (2) MI = Modem Interconnection
- (3) NC = No external connection (may have internal connection, leave pin disconnected (open)).
- (4) AGND is analog ground and DGND is digital ground.
- (5) Connect to VCC through 4.7 k Ω .
- (6) Connect ATL to + 5 VCC, ATLV to + 3 VCC.

勝特力材料 886-3-5753170
 勝特力电子(上海) 86-21-54151736
 勝特力电子(深圳) 86-755-83298787
[Http://www.100y.com.tw](http://www.100y.com.tw)

Table 3-4. RC224ATL/224ATLV 100-Pin PQFP Pin Assignments—Parallel (1 of 4)

Pin Number	Signal Label	I/O Type ⁽¹⁾
1	NC	—
2	IDLEN1	DI
3	RAGCO	MI ⁽²⁾ to RAGCI
4	RADCI	MI to RADCO
5	TSTBO	MI to TSTBI
6	NC ⁽³⁾	—
7	NC	—
8	NC	—
9	RSTBO	MI to RSTBI
10	RRSTO	MI to RRSTI
11	TRSTO	MI to TRSTI
12	MODEO	MI to MODEI
13	TDACO	MI to TDACI
14	SLEEP	DO
15	NC	—
16	DGND	DGND ⁽⁴⁾
17	MODEI	MI to MODEO
18	VAA	—
19	SPKR	O(DF)
20	NC	—
21	AGND	AGND
22	TXA2	O(DD)
23	TXA1	O(DD)
24	NC	—
25	RXA	I(DA)
26	NC	—

NOTE(S):

- (1) I/O Types are described in [Figure 7-5, Digital Interface Characteristics](#) and [Figure 7-6, Analog Interface Characteristics](#).
 (2) MI = Modem Interconnection.
 (3) NC = No external connection (may have internal connection, leave pin disconnected (open)).
 (4) AGND is analog ground and DGND is digital ground.
 (5) Connect to VCC through 4.7 kΩ.
 (6) Connect ATL to + 5 VCC, ATLV to + 3 VCC.

Table 3-4. RC224ATL/224ATLV 100-Pin PQFP Pin Assignments—Parallel (2 of 4)

Pin Number	Signal Label	I/O Type ⁽¹⁾
27	RFILO	—
28	AGCIN	—
29	VC	—
30	AGND	AGND
31	NC	—
32	NC	—
33	NC	—
34	NC	—
35	NC	—
36	$\overline{\text{TLKRELAY}}$	DO
37	AGND	AGND
38	$\overline{\text{OHRELAY}}$	DO
39	NC	—
40	NC	—
41	$\overline{\text{SLEEP1}}$	DI
42	RAGCI	MI to RAGCO
43	AGND	AGND
44	RSTBI	MI to RSTBO
45	RRSTI	MI to RRSTO
46	RADCO	MI to RADCI
47	TDACI	MI to TDACO
48	TRSTI	MI to TRSTO
49	TSTBI	MI to TSTBO
50	NC	—
51	NC	—
52	$\phi 2$	DI
53	$\overline{\text{TEST}}$	⁽⁵⁾

NOTE(S):

- (1) I/O Types are described in [Figure 7-5, Digital Interface Characteristics](#) and [Figure 7-6, Analog Interface Characteristics](#).
 (2) MI = Modem Interconnection.
 (3) NC = No external connection (may have internal connection, leave pin disconnected (open)).
 (4) AGND is analog ground and DGND is digital ground.
 (5) Connect to VCC through 4.7 k Ω .
 (6) Connect ATL to + 5 VCC, ATLV to + 3 VCC.

Table 3-4. RC224ATL/224ATLV 100-Pin PQFP Pin Assignments—Parallel (3 of 4)

Pin Number	Signal Label	I/O Type ⁽¹⁾
54	XTLI	IE
55	XTLO	OE
56	NC	—
57	DGND	DGND
58	DGND	DGND
59	NC	—
60	NC	—
61	HD0	DIO
62	HD1	DIO
63	HD2	DIO
64	HD3	DIO
65	$\overline{\text{MI}}$	(6)
66	DGND	DGND
67	NC	—
68	HD4	DIO
69	HD5	DIO
70	HD6	DIO
71	HD7	DIO
72	$\overline{\text{RING}}$	DI
73	NC	—
74	$\overline{\text{HRD}}$	DI
75	$\overline{\text{HWT}}$	DI
76	$\overline{\text{HCS}}$	DI
77	NVRCS	DO
78	HA2	DI
79	$\overline{\text{(A/A1)}}$	DO
80	DGND	DGND

NOTE(S):

- (1) I/O Types are described in [Figure 7-5, Digital Interface Characteristics](#) and [Figure 7-6, Analog Interface Characteristics](#).
- (2) MI = Modem Interconnection.
- (3) NC = No external connection (may have internal connection, leave pin disconnected (open)).
- (4) AGND is analog ground and DGND is digital ground.
- (5) Connect to VCC through 4.7 k Ω .
- (6) Connect ATL to + 5 VCC, ATLV to + 3 VCC.

Table 3-4. RC224ATL/224ATLV 100-Pin PQFP Pin Assignments—Parallel (4 of 4)

Pin Number	Signal Label	I/O Type ⁽¹⁾
81	DGND	DGND
82	NC	—
83	HA1	DI
84	HA0	DI
85	IDLENO	DI
86	NVRSK	DO
87	$\overline{\text{RESET}}$	IC
88	VCC	⁽⁶⁾
89	VCC	⁽⁶⁾
90	NC	—
91	HINT	DO
92	HDIS	DO
93	NC	—
94	NVRDIO	DIO
95	NC	—
96	NC	—
97	DGND	DGND
98	NC	—
99	NC	—
100	NC	—

NOTE(S):

(1) I/O Types are described in [Figure 7-5, Digital Interface Characteristics](#) and [Figure 7-6, Analog Interface Characteristics](#).

(2) MI = Modem Interconnection.

(3) NC = No external connection (may have internal connection, leave pin disconnected (open)).

(4) AGND is analog ground and DGND is digital ground.

(5) Connect to VCC through 4.7 k Ω .

(6) Connect ATL to +5 VCC, ATLV to +3 VCC.

勝特力材料 886-3-5753170
 勝特力电子(上海) 86-21-54151736
 勝特力电子(深圳) 86-755-83298787
[Http://www.100y.com.tw](http://www.100y.com.tw)

Table 3-5. Hardware Interface Signal Definitions (1 of 5)

Label	I/O Type	Signal Name/Description															
System Signals																	
XTLI XTLO	IE OE	Crystal/Clock In and Crystal Out. The modem must be connected to an external crystal circuit consisting of a 16.000312 MHz crystal and two capacitors. Alternatively, XTLI may be driven with a buffered clock, in which case XTLO should be left open.															
$\overline{\text{RESET}}$	IC	Reset. The active low $\overline{\text{RESET}}$ input resets the internal modem logic. Upon $\overline{\text{RESET}}$ transitioning from high to low, modem operation returns to the state controlled by factory default values and stored values in NVRAM. During modem power-on, $\overline{\text{RESET}}$ must be held low for at least 5 ms after +5 VD and +5 VA operating voltage (see TSVD and +5 VA below) is attained for the modem to stabilize. When the serial interface is selected, $\overline{\text{RESET}}$ can be connected to an external RC network to cause the modem to reset upon power turn on. When the parallel interface is selected, $\overline{\text{RESET}}$ should be connected to the hose bus reset line.															
$\overline{\text{SEREN}}$	DI	Serial Interface Enable. When the $\overline{\text{SEREN}}$ input is low, serial interface is selected upon reset. In this case, the serial interface signals should be connected to the V.24 (EIA-232-D) interface and LED indicators.															
VCC VAA	PWR	Digital Supply. +5 V/3.3V ATLV $\pm 5\%$ is required. Analog Supply. +5 V $\pm 5\%$ is required.															
DGND AGND	GND	Digital and Analog Grounds.															
Sleep Mode Signals																	
IDLENO IDLEN1	DI DI	Idle Enable 0 and Idle Enable 1. Encoded inputs enable or disable the sleep modes as follows: <table style="margin-left: auto; margin-right: auto;"> <thead> <tr> <th>IDLEN1</th> <th>IDLENO</th> <th>Mode</th> </tr> </thead> <tbody> <tr> <td>L</td> <td>L</td> <td>Idle mode disabled</td> </tr> <tr> <td>L</td> <td>H</td> <td>Idle mode enabled</td> </tr> <tr> <td>H</td> <td>L</td> <td>Stop mode disabled</td> </tr> <tr> <td>H</td> <td>H</td> <td>Stop mode enabled</td> </tr> </tbody> </table> If Idle option is enabled, the modem will enter idle mode after 5 seconds of inactivity ($\overline{\text{WAKEUP}}$ must also be high for the serial interface). The modem will wakeup upon DTE activity (RXD for parallel mode and low on $\overline{\text{WAKEUP}}$ for serial mode) or the presence of RING. If Stop option is selected, the $\overline{\text{RING}}$ input becomes RING (i.e., the $\overline{\text{RING}}$ signal must be inverted). The modem will enter stop mode after 5 seconds of inactivity (and if $\overline{\text{WAKEUP}}$ is high for the serial interface). Only a 4 ms or longer pulse on the RING pin can wake up the modem from stop mode.	IDLEN1	IDLENO	Mode	L	L	Idle mode disabled	L	H	Idle mode enabled	H	L	Stop mode disabled	H	H	Stop mode enabled
IDLEN1	IDLENO	Mode															
L	L	Idle mode disabled															
L	H	Idle mode enabled															
H	L	Stop mode disabled															
H	H	Stop mode enabled															
$\overline{\text{SLEEP}}$	DO	Sleep Mode. $\overline{\text{SLEEP}}$ output high indicates the modem is operating in its normal mode. $\overline{\text{SLEEP}}$ low indicates that the modem is in the sleep mode. The $\overline{\text{SLEEP}}$ output can also be used to control power to other devices.															
$\overline{\text{SLEEP}}$	DI	Sleep Mode. $\overline{\text{SLEEP}}$ input low causes the Integrated Analog (IA) to enter low-power sleep mode.															

勝特力材料 886-3-5753170
 勝特力电子(上海) 86-21-54151736
 勝特力电子(深圳) 86-755-83298787
[Http://www.100y.com.tw](http://www.100y.com.tw)

Table 3-5. Hardware Interface Signal Definitions (2 of 5)

Label	I/O Type	Signal Name/Description
$\overline{\text{WAKEUP}}$	DI	Wake Up. For serial interfaces only, $\overline{\text{WAKEUP}}$ input low removes the modem from the sleep mode (if in the sleep mode), or prevents the modem from entering the sleep mode (if not in the sleep mode). $\overline{\text{WAKEUP}}$ high allows the modem to enter sleep mode after 5 seconds of modem inactivity. $\overline{\text{WAKEUP}}$ is typically connected to DTR or TXD.
NVRAM Interface		
NVRCS	DO	NVRAM Chip Select. NVRCS output high enables the NVRAM.
NVRSK	DO	NVRAM Shift Clock. The NVRSK output is used to shift data to or from the NVRAM.
NVRDIO	DIO	NVRAM Data In/NVRAM Data Out. NVRDIO is a bidirectional signal that carries both the serial input data from the NVRAM and the serial output data to the NVRAM. Depending on the specific NVRAM used, a resistor may be required between the NVRAM DO output pin and the modem NVRDIO bidirectional line. (Refer to Figure 3-5 and the NVRAM data sheet.)
Speaker Interface		
SPKR	O(DF)	Speaker Analog Output. The SPKR output reflects the output of the receive analog signal. The SPKR output is turned on or off by the Speaker Control Option (Mn command), and the gain is controlled by the Speaker Volume Option (Ln command). When the speaker is turned off, the SPKR output is clamped to the voltage at the VC pin. The SPKR output can drive a load as low as 300 Ω . Typically, the SPKR output is an input to an external LM386 audio power amplifier.
Asynchronous Serial Interface (Serial Interface Only; $\overline{\text{SEREN}}$ = Low)		
$\overline{\text{RXD}}$	DO	Received Data. The modem presents received serial data to the $\overline{\text{RXD}}$ output pin.
$\overline{\text{TXD}}$	DI	Transmitted Data. The modem obtains serial data to be transmitted from the $\overline{\text{TXD}}$ pin.
$\overline{\text{DTR}}$	DI	Data Terminal Ready. $\overline{\text{DTR}}$ input ON (low) indicates that the DTE is ready to operate. $\overline{\text{DTR}}$ input OFF (high) indicates that the DTE is not ready to operate.
$\overline{\text{CTS}}$	DO	Clear to Send. In data modes, the $\overline{\text{CTS}}$ output is ON; in fax modes, $\overline{\text{CTS}}$ is optionally used for flow control.
$\overline{\text{DSR}}$	DO	Data Set Ready. The $\overline{\text{DSR}}$ output is controlled by the AT&Sn command.
$\overline{\text{DCD}}$	DO	Data Carrier Detected. The $\overline{\text{DCD}}$ output is controlled by the AT&C command.
$\overline{\text{CI/HS}}$	DO	Calling Indicator/High Speed Indicator. $\overline{\text{CI/HS}}$ output ON (low) indicates modem connection at 2400 bps.
$\overline{\text{RI}}$	DO	Ring Indicator. $\overline{\text{RI}}$ output ON (low) indicates the presence of an ON segment of a ring signal on the telephone line. (The ring signal cycle is typically 2 seconds ON, 4 seconds OFF.) The OFF (high) condition of the $\overline{\text{RI}}$ output is maintained during the OFF segment of the ring cycle (between rings) and at all other times when ringing is not being received.
Serial Indicator Interface (Serial Interface Only; $\overline{\text{SEREN}}$ = Low)		
$\overline{\text{AAE}}$	DO	Auto Answer Enable. $\overline{\text{AAE}}$ output ON (low) indicates that modem auto answer mode has been enabled with the S0 = command. $\overline{\text{AAE}}$ high indicates auto answer has been disabled. The AAE output also indicates the status of the $\overline{\text{RI}}$ output.
$\overline{\text{MR}}$	DO	Modem Ready. $\overline{\text{MR}}$ output ON (low) indicates that the modem is ready; i.e., modem power is on and a test mode is not selected. In a test mode, the $\overline{\text{MR}}$ output pulses to indicate a test is in process.

Table 3-5. Hardware Interface Signal Definitions (3 of 5)

Label	I/O Type	Signal Name/Description																																																		
$\overline{\text{DCDL}}$	DO	DCD Indicator. The $\overline{\text{DCDL}}$ output is controlled by the AT&C command.																																																		
$\overline{\text{DTRL}}$	DO	DTR Indicator. The $\overline{\text{DTRL}}$ output is controlled by the AT&D command.																																																		
Parallel Host Interface (Parallel Interface Only)																																																				
		<p>When the $\overline{\text{HWT}}$ input signal is connected to the host bus write line, the parallel interface is selected upon reset. (See Section 7.3, <i>Interface Timing and Waveforms</i> for waveform and timing information.)</p> <p>The parallel interface emulates a 16C450 UART; (See Table 2-1, <i>Parallel Interface Registers</i>). Parallel interface operation is equivalent to 16C450 operation with CS0 and CS1 inputs high and DISTR, DOSTR, and ADS inputs low. The corresponding RC224ATLV and 16C450 signals are shown below. 16C450 signals that are not required for RC224ATLV host computer operation are not shown.</p> <table border="0"> <thead> <tr> <th>16C450 Signal</th> <th>RC224ATLV Signal</th> </tr> </thead> <tbody> <tr> <td>A0 - A2</td> <td>HA0 - HA2</td> </tr> <tr> <td>D0 - D7</td> <td>HD0 - HD7</td> </tr> <tr> <td>$\overline{\text{MR}}$</td> <td>$\overline{\text{RESET}}$ (Active low)</td> </tr> <tr> <td>CS2</td> <td>$\overline{\text{HCS}}$</td> </tr> <tr> <td>$\overline{\text{DISTR}}$</td> <td>$\overline{\text{HWT}}$</td> </tr> <tr> <td>$\overline{\text{DOSTR}}$</td> <td>$\overline{\text{HRD}}$</td> </tr> <tr> <td>$\overline{\text{INTRPT}}$</td> <td>HINT</td> </tr> <tr> <td>$\overline{\text{DDIS}}$</td> <td>HDIS</td> </tr> <tr> <td>OUT2</td> <td>None (Implemented internally in RC224ATLV)</td> </tr> </tbody> </table>	16C450 Signal	RC224ATLV Signal	A0 - A2	HA0 - HA2	D0 - D7	HD0 - HD7	$\overline{\text{MR}}$	$\overline{\text{RESET}}$ (Active low)	CS2	$\overline{\text{HCS}}$	$\overline{\text{DISTR}}$	$\overline{\text{HWT}}$	$\overline{\text{DOSTR}}$	$\overline{\text{HRD}}$	$\overline{\text{INTRPT}}$	HINT	$\overline{\text{DDIS}}$	HDIS	OUT2	None (Implemented internally in RC224ATLV)																														
16C450 Signal	RC224ATLV Signal																																																			
A0 - A2	HA0 - HA2																																																			
D0 - D7	HD0 - HD7																																																			
$\overline{\text{MR}}$	$\overline{\text{RESET}}$ (Active low)																																																			
CS2	$\overline{\text{HCS}}$																																																			
$\overline{\text{DISTR}}$	$\overline{\text{HWT}}$																																																			
$\overline{\text{DOSTR}}$	$\overline{\text{HRD}}$																																																			
$\overline{\text{INTRPT}}$	HINT																																																			
$\overline{\text{DDIS}}$	HDIS																																																			
OUT2	None (Implemented internally in RC224ATLV)																																																			
HA0-HA2	DI	<p>Host Bus Address Lines 0-2. During a host read or write operation, signals HA0–HA2 select an internal register. The state of the divisor latch access bit (DLAB) affects the selection of certain registers.</p> <p>Host Bus Data Lines 0-7. HD0-HD7 are comprised of eight tri-state I/O lines providing bidirectional communication between the host and the modem. Data, control words, and status information are transferred through HD0-HD7.</p> <table border="0"> <thead> <tr> <th>DLAB</th> <th>HA2</th> <th>HA1</th> <th>HA0</th> <th>Register</th> </tr> </thead> <tbody> <tr> <td>0</td> <td>0</td> <td>0</td> <td>0</td> <td>Receive Buffer Register (Read), Transmitter Holding Register (Write)</td> </tr> <tr> <td>0</td> <td>0</td> <td>0</td> <td>1</td> <td>Interrupt Enable Register</td> </tr> <tr> <td>X</td> <td>0</td> <td>1</td> <td>0</td> <td>Interrupt Identification Register (Read Only)</td> </tr> <tr> <td>X</td> <td>0</td> <td>1</td> <td>1</td> <td>Line Control Register</td> </tr> <tr> <td>X</td> <td>1</td> <td>0</td> <td>0</td> <td>Modem Control Register</td> </tr> <tr> <td>X</td> <td>1</td> <td>0</td> <td>1</td> <td>Line Status Register (Read Only)</td> </tr> <tr> <td>X</td> <td>1</td> <td>1</td> <td>1</td> <td>Scratch Register</td> </tr> <tr> <td>1</td> <td>0</td> <td>0</td> <td>0</td> <td>Divisor Latch Register (Least Significant Byte)</td> </tr> <tr> <td>1</td> <td>0</td> <td>0</td> <td>1</td> <td>Divisor Latch Register (Most Significant Byte)</td> </tr> </tbody> </table>	DLAB	HA2	HA1	HA0	Register	0	0	0	0	Receive Buffer Register (Read), Transmitter Holding Register (Write)	0	0	0	1	Interrupt Enable Register	X	0	1	0	Interrupt Identification Register (Read Only)	X	0	1	1	Line Control Register	X	1	0	0	Modem Control Register	X	1	0	1	Line Status Register (Read Only)	X	1	1	1	Scratch Register	1	0	0	0	Divisor Latch Register (Least Significant Byte)	1	0	0	1	Divisor Latch Register (Most Significant Byte)
DLAB	HA2		HA1	HA0	Register																																															
0	0	0	0	Receive Buffer Register (Read), Transmitter Holding Register (Write)																																																
0	0	0	1	Interrupt Enable Register																																																
X	0	1	0	Interrupt Identification Register (Read Only)																																																
X	0	1	1	Line Control Register																																																
X	1	0	0	Modem Control Register																																																
X	1	0	1	Line Status Register (Read Only)																																																
X	1	1	1	Scratch Register																																																
1	0	0	0	Divisor Latch Register (Least Significant Byte)																																																
1	0	0	1	Divisor Latch Register (Most Significant Byte)																																																
HD0-HD7	DIO																																																			
$\overline{\text{HCS}}$	DI	Host Bus Chip Select. $\overline{\text{HCS}}$ input low enables reading from or writing to the modem using the parallel bus.																																																		
$\overline{\text{HRD}}$	DI	Host Bus Read. $\overline{\text{HRD}}$ is an active low read control input. When the modem is selected with $\overline{\text{HCS}}$, $\overline{\text{HRD}}$ low allows status or data words to be read from an addressed register.																																																		
$\overline{\text{HWT}}$	DI	Host Bus Write. $\overline{\text{HWT}}$ is an active low write control input. When the modem is selected with $\overline{\text{HCS}}$, $\overline{\text{HWT}}$ low allows data or control words to be written to an addressed register.																																																		

Table 3-5. Hardware Interface Signal Definitions (4 of 5)

Label	I/O Type	Signal Name/Description
HDIS	DO	Host Bus Driver Disable. HDIS output is low when the host is reading data from the modem over the host data bus (both HRD and HCS are low). HDIS is also used to disable the external transceiver drivers whenever data is not being read from the modem.
HINT	DO	Host Bus Interrupt. HINT output is 16C450-compatible output indicating interrupt status and is enabled by the OUT2 bit set to a 1 in the Modem Control Register.
Telephone Line Interface		
TXA1 TXA2	O(DF)	Transmit Analog 1 and 2. The TXA1 and TXA2 outputs are differential outputs. A 600 Ω telephone coupling transformer may be driven directly without the need for external discrete buffer amplifiers. Both TXA1 and TXA2 outputs are turned off when the transmitter is disabled or during local analog loopback.
RXA	I(DA)	Receive Analog. RXA is a single-ended receive data input from the telephone line interface.
VC	OA	Centerpoint Voltage. A +2.5 VDC centerpoint voltage derived from an internal reference voltage. The TXA1 and TXA2 outputs are biased at VC.
$\overline{\text{TLKRELAY}}$	DO	Talk/Data Relay Driver. $\overline{\text{TLKRELAY}}$ is an open drain output which can directly drive a relay with greater than 360 Ω coil resistance and has “must operate” voltage of no greater than 4.0 VDC. A heavier load, such as an electro-mechanical relay, requires the use of an external transistor. An external diode should be provided across the relay coil. The $\overline{\text{TLKRELAY}}$ output is clamped off during power-on reset or the sleep mode. The $\overline{\text{TLKRELAY}}$ output is activated and deactivated at the same time as the $\overline{\text{OHRELAY}}$ output. In a typical application, $\overline{\text{TLKRELAY}}$ ON opens the normally closed Talk/Data relay and disconnects the handset from the telephone line.
$\overline{\text{OHRELAY}}$	DO	Off-Hook Relay Driver. $\overline{\text{OHRELAY}}$ is an open drain output which can directly drive a relay with greater than 360 Ω coil resistance and has “must operate” voltage of no greater than 4.0 VDC. A heavier load, such as an electro-mechanical relay, requires the use of an external transistor. An external diode should be provided across the relay coil. The $\overline{\text{OHRELAY}}$ output is clamped off during power-on reset or the sleep mode. In a typical application, $\overline{\text{OHRELAY}}$ ON closes the normally open Off-Hook relay and connects the modem to the telephone line (off-hook).
$\overline{\text{RING}}$	DI	Ring Detector. $\overline{\text{RING}}$ is a TTL-compatible input used to indicate to the modem that a 15.3 Hz to 63 Hz ringing signal is present. The signal (a 4N35 optoisolator compatible output) into the $\overline{\text{RING}}$ input should not respond to a voltage less than 40 V _{RMS} , 15 Hz to 68 Hz, appearing across TIP and RING with respect to ground. A low-going edge on the $\overline{\text{RING}}$ input also removes the modem from the sleep mode.
$\overline{\text{A/A1}}$	DO	Key Telephone Hold Indicator. $\overline{\text{A/A1}}$ output low indicates that the telephone line is in use when used on multi-line key telephones.

勝特力材料 886-3-5753170
 勝特力电子(上海) 86-21-54151736
 勝特力电子(深圳) 86-755-83298787
 Http://www.100y.com.tw

Table 3-5. Hardware Interface Signal Definitions (5 of 5)

Label	I/O Type	Signal Name/Description
Modem Interconnect		
RFILO	MI	Receive Filter Output. RFILO is the output of the internal receive anti-aliasing filter which must be connected to AGCIN through a 0.1 μ F, 20%, DC decoupling capacitor. The 1000 pF capacitor to ground provides noise immunity at low noise levels.
AGCIN	MI	Receive AGC Gain Amplifier Input. See RFILO.
MODEO (DSP), MODEI (IA)	MI	Mode Control. Direct modem interconnect line.
TDACO (DSP), TDACI (IA)	MI	Transmitter DAC Signal. Serial digital DAC signal. Direct modem interconnect line.
TSTBO (DSP), TSTBI (IA)	MI	Transmitter Strobe. 576 kHz digital transmitter timing reference. Direct modem interconnect line.
TRSTO (DSP), TRSTI (IA)	MI	Transmitter Reset. 9.6 kHz, 8228.57 Hz, or 7.2 kHz digital transmitter timing reference. Direct modem interconnect line.
RADCI (DSP), RADCO (IA)	MI	Receiver ADC Signal. Serial digital ADC signal. Direct modem interconnect line.
RAGCO (DSP), RAGCI (IA)	MI	Receiver AGC Signal. Serial digital AGC signal. Direct modem interconnect line.
RRSTO (DPS), RRSTI (IA)	MI	Receiver Reset. 9.6 kHz, 8228.57 Hz, or 7.2 kHz digital receiver timing reference. Direct modem interconnect line.
RSTBO (DSP), RSTBI (IA)	MI	Receiver Strobe. 576 kHz digital receiver timing reference. Direct modem interconnect line.

勝特力材料 886-3-5753170
 勝特力电子(上海) 86-21-54151736
 勝特力电子(深圳) 86-755-83298787
[Http://www.100y.com.tw](http://www.100y.com.tw)

Figure 3-5. NVRAM Timing

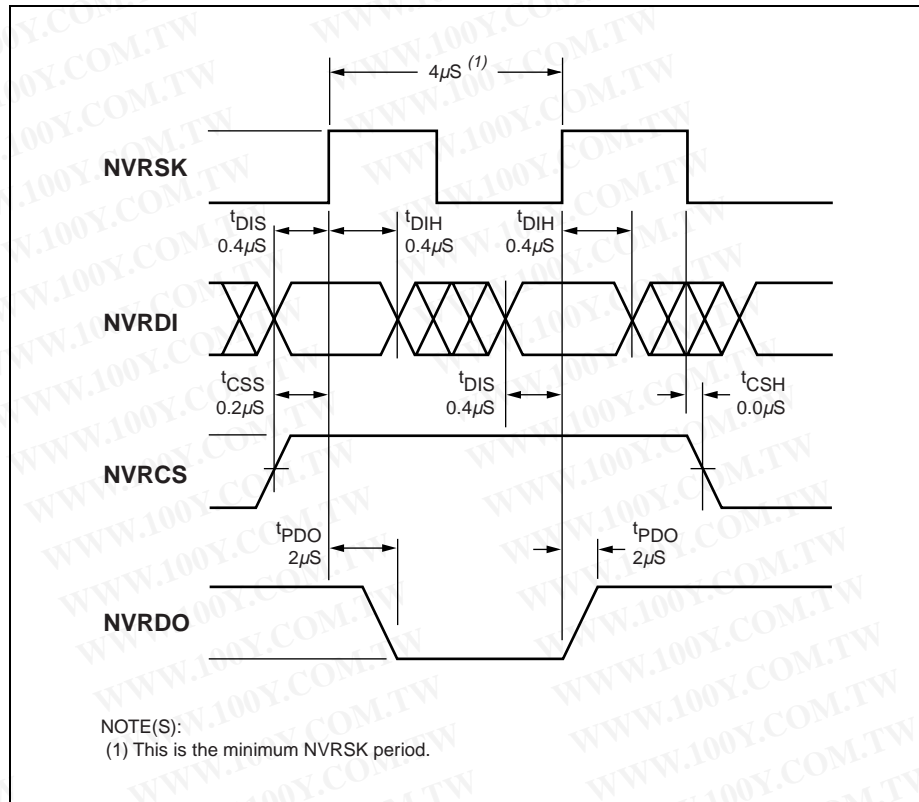

勝特力材料 886-3-5753170
 勝特力电子(上海) 86-21-54151736
 勝特力电子(深圳) 86-755-83298787
[Http://www.100y.com.tw](http://www.100y.com.tw)

勝特力材料 886-3-5753170
 勝特力电子(上海) 86-21-54151736
 勝特力电子(深圳) 86-755-83298787
 Http://www.100y.com.tw

4.0 AT Commands

Each command line must start with the AT prefix and be terminated with a carriage return (CR). Several commands may be included on one command line. A command line may contain up to 40 characters, excluding the AT prefix and the terminating CR. A separator is not required between data commands. A semicolon (;) separator is required between fax commands.

AT commands are composed of 10-bit ASCII encoded asynchronous characters. The character format in data mode is 8 data bits with no parity, or 7 data bits with even, odd, or no (two stop bits) parity, at a data rate of 19,200, 2400, 1200, or 300 bps. The character format in fax mode is 8 data bits with no parity at 19,200 bps.

Table 4-1 lists result codes and messages. Table 4-2 summarizes the AT command set. Table 4-3 summarizes the fax command set.

Table 4-1. Result Codes and Messages

Digital Code	Word Code	Meaning
0	OK	Command line executed without errors
1	CONNECT	Connection at 300 bps
2	RING	Ringing signal detected
3	NO CARRIER	Carrier lost or never present
4	ERROR	Invalid command, checksum, error in command line, or command line exceeds 40 characters
5	CONNECT 1200	Connection at 1200 bps
6	NO DIALTONE	No dial tone detected
7	BUSY	Busy signal detected
8	NO ANSWER	No silence detected when dialing a system not providing a dial tone
10	CONNECT 2400	Connection at 2400 bps
+F4	+FCERROR	Fax carrier error
13	DATA	Connected as data modem during auto answer
15	FAX	Connected as fax modem during auto answer

Table 4-2. AT Command Set Summary (1 of 5)

Command	Function	Default	Parameters/Description
A/	Re-execute command	—	—
A	Answer a call	—	—
AT	Command line prefix Parameters: none	—	Attention Code. Precedes the command line except for +++ (escape) and A/ (repeat) commands.
Bn	Select CCITT or Bell Mode Parameters: n = 0,1	n = 1	n = 0 Selects CCITT operation at 300 or 1200 bps during Call Establishment and a subsequent connection. n = 1 Selects BELL operation at 300 or 1200 bps during Call Establishment and a subsequent connection.
Cn	Carrier control Parameters: n = 0,1	n = 1	—
D	—	—	Dial Command. D causes the modem to dial the number which follows the D in the command line. Valid dial characteristics are 0 to 9, A to D, #, and *. Other valid dial modifier characters are “,” P, R, S=n, T, W, “;”, @, and !.
Dn	Dial modifier	—	—
En	Command echo Parameters: n = 0,1	n = 1	n = 0 Disables command echo. n = 1 Enables command echo.
Fn	On-line character echo option Parameters: n = 0,1	n = 1	n = 0 Returns ERROR result code. n = 1 Returns OK result code.
Hn	Disconnect (hang-up) Parameters: n = 0,1	n = 0	n = 0 Modem on-hook (relay open). n = 1 Modem off-hook (relay closed).
In	Identification Parameters: n = 0,1,2,3	n = 0	n = 0 Reports product identification code. n = 1 Calculates the ROM checksum. n = 2 Calculates the ROM checksum and compares it with the prestored checksum. Reports "OK" if the calculated checksum equals the prestored checksum or if the prestored checksum value is FFh; otherwise reports "ERROR". n = 3 Reports the firmware version and ROM part number.
Ln	Speaker volume Parameters: n = 0,1,2,3	n = 2	n = 0 Low volume. n = 1 Low volume. n = 2 Medium volume. n = 3 High volume.
Mn	Speaker control Parameters: n = 0,1,2,3	n = 1	n = 0 Speaker is always off. n = 1 Speaker is on during Call Establishment, but off when receiving carrier. n = 2 Speaker is always on. n = 3 Speaker is on after dialing, until carrier is detected.
On	Go on-line Parameters: n = 0,1	—	n = 0 On-line state. n = 1 On-line state with equalizer retrain.
P	Force pulse dialing	—	—
Qn	Quiet Result codes control	n = 0	n = 0 Enables result codes to the DTE. n = 1 Disables result codes to the DTE.

EmbeddedModem Family

Table 4-2. AT Command Set Summary (2 of 5)

Command	Function	Default	Parameters/Description
Sn	Select S register as default Range: n = 0-27	—	n Establishes S-Register n as the last register accessed. n = v Sets S-Register n to the value v. n? Reports the value of S-Register n.
Sn =	Parameters: none Range: n = 0-27 (register no.) x=0-255 (value)	—	Writes to an S Register. Sr=x sets register “n” to the value “x”. Configuration registers are provided to retain modem configuration parameters. The contents of these registers can be modified with this command.
Sn?	Parameters: none Range: n = 0-27	—	Reads an S register. Sn? causes the contents stored in register “n” to be returned.
T	Force DTMF dialing	—	—
Vn	Report codes form	n = 1	n = 0 Result code is sent as a digit. n = 1 Result code is sent as ASCII text.
Xn	Extended result codes	n = 4	n = 0 Basic set of result codes 0-4 are enabled. The modem blind dials and sends the appropriate connect result code once a satisfactory connection is established. Dial tone and busy are not recognized. n = 1 Result codes 0-5 and 10 are enabled. The modem blind dials and sends the appropriate connect result code once a satisfactory connection is established. Dial tone and busy are not recognized. n = 2 Result codes 0-6 and 10 are enabled; dial tone detected. The modem waits for a dial tone before dialing, then sends the appropriate result code once a satisfactory connection is established. The busy result code is sent if a busy signal is detected. n = 3 Result codes 0-5, 7 and 10 are enabled; busy signal detected; dial tone not detected. The modem blind dials and sends the appropriate connect result code once a satisfactory connection is established. The busy result code is sent if a busy signal is detected. n = 4 Result codes 0-7 and 10 are enabled; busy signal and dial tone detected. The modem waits for a dial tone before dialing, then sends the appropriate result code once a satisfactory connection is established. The NO DIALTONE result code is sent if the dial tone is not detected within 5 seconds. The BUSY result code is sent if a busy signal is detected.
Yn	Long space disconnect	n = 0	n = 0 Disables long space disconnect. n = 1 Enables long space disconnect.
Zn	Soft reset and restore profile	n = 0	n = 0 Soft reset. Restores stored profile 0. n = 1 Soft reset. Restores stored profile 1.
&Cn	RLSD (DCD) option	n = 0	n = 0 RLSD remains ON at all times. n = 1 RLSD follows the state of the carrier.

勝特力材料 886-3-5753170
 勝特力电子(上海) 86-21-54151736
 勝特力电子(深圳) 86-755-83298787
[Http://www.100y.com.tw](http://www.100y.com.tw)

Table 4-2. AT Command Set Summary (3 of 5)

Command	Function	Default	Parameters/Description															
&Dn	DTR option	n = 0	<p>n = 0 Modem ignores DTR.</p> <p>n = 1 Modem assumes command state when ON-to-OFF transition is detected on DTR.</p> <p>n = 2 Modem hangs up, assumes command state and disables auto-answer upon detecting ON-to-OFF transition on DTR.</p> <p>n = 3 Modem assumes software reset state upon detecting ON-to-OFF transition on DTR.</p>															
&F	Recall (restore) factory profile	—	<p>S Registers: S0=1, S1=0, S2=43, S3=13, S4=10, S5=8, S6=0, S7=30, S8=2, S9=5, S10=14, S11=95, S12=50, S18=0, S25=5, S26=1</p> <p>Commands: B1, C1, E1, F1, L2, M1, P, Q0, V1, Y0, X4, &C0, &D0, &G0, &J0, &M0/&G0, &P0, &R0, &S0, &T4, &X0</p>															
&Gn	Select guard tone	n = 0	<p>n = 0 No guard tone.</p> <p>n = 1 550 Hz guard tone.</p> <p>n = 2 1800 Hz guard tone.</p>															
&Jn	Telephone jack control	n = 0	<p>n = 0 Suitable for RJ11, RJ41S, or RJ45S type phone jack.</p> <p>n = 1 Suitable for RJ12 or RJ13 type phone jack; the A lead is connected to A1 lead while the modem is off-hook.</p>															
&L0	Dial-up line operation	n = 0	n = 0 Requests dial-up operation.															
&Mn	Asynchronous mode	n = 0	<p>n = 0 Asynchronous operation.</p> <p>n = 1 Reserved</p> <p>n = 2 Reserved</p> <p>n = 3 Reserved</p>															
&Pn	Pulse dial make/break ratio	n = 0	<p>n = 0 Selects 39%–61% make/break ratio at 10 pps. (USA/Canada)</p> <p>n = 1 Selects 33%–67% make/break ratio at 10 pps. (UK/HK)</p>															
&Q0	Asynchronous mode	n = 0	<table border="0"> <thead> <tr> <th></th> <th>Idle State</th> <th>On-line State</th> </tr> </thead> <tbody> <tr> <td>n = 0</td> <td>Normal</td> <td>Asynchronous</td> </tr> <tr> <td>n = 1</td> <td>Reserved</td> <td>Reserved</td> </tr> <tr> <td>n = 2</td> <td>Reserved</td> <td>Reserved</td> </tr> <tr> <td>n = 3</td> <td>Reserved</td> <td>Reserved</td> </tr> </tbody> </table>		Idle State	On-line State	n = 0	Normal	Asynchronous	n = 1	Reserved	Reserved	n = 2	Reserved	Reserved	n = 3	Reserved	Reserved
	Idle State	On-line State																
n = 0	Normal	Asynchronous																
n = 1	Reserved	Reserved																
n = 2	Reserved	Reserved																
n = 3	Reserved	Reserved																
&Sn	DSR override	n = 0	<p>n = 0 DSR will remain ON at all times.</p> <p>n = 1 DSR will become active after answer tone has been detected and inactive after the carrier has been lost. DSR is OFF when the modem is in test mode or idle state.</p>															

勝特力材料 886-3-5753170
 勝特力电子(上海) 86-21-54151736
 勝特力电子(深圳) 86-755-83298787
[Http://www.100y.com.tw](http://www.100y.com.tw)

Table 4-2. AT Command Set Summary (4 of 5)

Command	Function	Default	Parameters/Description
&Tn	Test and diagnostic	n = 4	<p>n = 0 Terminates test in progress.</p> <p>n = 1 Initiates local analog loopback.</p> <p>n = 2 Returns ERROR.</p> <p>n = 3 Initiates local digital loopback.</p> <p>n = 4 Enables digital loopback acknowledgment from remote modem for RDL.</p> <p>n = 5 Disables digital loopback acknowledgment from remote modem for RDL.</p> <p>n = 6 Initiates remote digital loopback.⁽¹⁾</p> <p>n = 7 Initiates remote digital loopback with self test.⁽¹⁾</p> <p>n = 8 Initiates local analog loopback with self test.⁽¹⁾</p>
&V	Display current configurations	—	<p>Example: AT&V ACTIVE PROFILE: B0 E1 L1 M1 Q0 T V1 Y0 &C0 &D0 &G2 &J0 &L0 &P0 &Q0 &R0 &S0 &X0 &Y0 S00:000 S01:000 S02:043 S03:013 S04:010 S05:008 S06:002 S07:030 S08:002 S09:006 S10:014 S12:050 S14:AAH S16:00H S18:000 S21:00H S22:76H S23:17H S25:005 S26:001 S27:40H STORED PROFILE 0: B1 E1 L2 Q0 V1 X4 Y0 &C0 &D0 &G0 &J0 &L0 &P0 &Q0 &R0 &S0 &X0 S00:000 S14:AAH S18:000 S21:00H S22:76H S23:17H S25:005 S26:001 S27:40H STORED PROFILE 1: B1 E1 L2 Q0 V1 X4 Y0 &C0 &D0 &G0 &J0 &L0 &P0 &Q0 &R0 &S0 &X0 S00:000 S14:AAH S18:000 S21:00H S22:76H S23:17H S25:005 S26:001 S27:40H TELEPHONE NUMBERS: &Z0= 5551212 &Z1= &Z2= &Z3=</p>
&Wn	Store current configuration	n = 0	<p>Commands: Bn, En, Ln, Mn, P or T, Qn, Vn, Yn, &Cn &Dn, &Gn, &Jn, &Ln, &Pn, &Qn, &Rn, &Sn &Xn &Yn</p> <p>Registers: S0, S1, S2, S3, S4, S5, S6, S7, S8, S9, S10, S12, S14, S16, S18, S21, S22, S23, S25, S26, S27</p> <p>n = 0 Stores active profile in location 0. n = 1 Stores active profile in location 1.</p>
&X0	Asynchronous data transmission	n = 0	<p>n = 0 Reserved</p> <p>n = 1 Reserved</p> <p>n = 2 Reserved</p>
&Yn	Select default profile	—	<p>n = 0 The modem will use profile 0 on powerup.</p> <p>n = 1 The modem will use profile 1 on powerup.</p>
&Zn = x	Store dial string to location n	—	&Zn = x n = 0 to 3 and x = dial string. (up to 36 characters)

勝特力材料 886-3-5753170
 勝特力电子(上海) 86-21-54151736
 勝特力电子(深圳) 86-755-83298787
[Http://www.100y.com.tw](http://www.100y.com.tw)

Table 4-2. AT Command Set Summary (5 of 5)

Command	Function	Default	Parameters/Description
%Dn	DTMF Level Attenuation	—	—
%J	Load Secondary Defaults	—	—
%Ln	Transmit Level Attenuation	—	—
Dial Modifier	Function		
P	Pulse Dial Parameters: none	—	—
R	Originate Call in Answer Mode Parameters: none	—	—
S=n	Dial Stored Number Parameters: n = 0, 1, 2, 3 S<CR> S=<CR> S=n<CR> where n = 0-3	—	—
T	Tone Dial Parameters: none	—	—
W	Wait for Dial Tone Parameters: none	—	—
;	Return to Idle State Parameters: none	—	—
@	Wait for Quiet Answer Command Parameters: none	—	—
!	Flash Hook Parameters: none	—	—
, (comma)	Pause Parameters: none	—	—
0-9, A, B, C, D, #, *	Dial Digits/Characters Parameters: none	—	—
NOTE(S): (1) Not available for 300 bps.			

勝特力材料 886-3-5753170
 勝特力电子(上海) 86-21-54151736
 勝特力电子(深圳) 86-755-83298787
[Http://www.100y.com.tw](http://www.100y.com.tw)

Table 4-3. Fax Command Set Summary (1 of 2)

Fax Command	Function	Default	Parameters/Description
+FCLASS=n	Service class	n = 0	Select Service Class. +FCLASS=n command sets the active service class. +FCLASS=0 Returns to data mode +FCLASS=1 Fax Class 1 +FCLASS=2 Fax Class 2 (Not supported) +FCLASS=3 Fax Class 3 (Not supported)
+F<command>?	Report Active Configuration	—	Report Active Configuration. +F<command>? interrogates the modem to determine the active configuration. The responses are: +FAA? 0 if auto answer is disabled; 1 if auto answer is enabled +FCLASS 0 if in data mode; 1 if in fax class 1 +FF? 0 if flow control off; 1 if flow control on
+F<command>=?	Report Operating Capabilities	—	Report Operating Capabilities. +F<commands>=? can be used to determine the operating capabilities of the modem. The responses are: +FAA=? 0, 1 +FCLASS=? 0, 1 +FTM=? 24, 48, 72, 96 +FTM=? 24, 48 +FTH=? 3 +FTH=? 3 +FF=? 0,1
+FAA=n	Data/Fax Auto Answer	n = 0	Data/Fax Auto Answer. +FAA command configures the modem to automatically detect whether an incoming call is from a data modem or a fax modem. This command is valid in both data and fax modes. n = 0 Disable data/fax auto answer mode (default). n = 1 Enable data/fax auto answer mode. The modem determines calling type and issues DATA result code (13) if caller is a data modem, or issues FAX result code (15) in the caller is a fax modem.
+FF	Enhanced Flow Control	n = 0	Enhanced Flow Control. +FF=n command enables an enhanced flow control mode for data transfer between the DTE and DCE. n = 0 Disables enhanced flow control interface. In this mode, data transfer is compatible with the EIA-578 standard. n = 1 Enables enhanced flow control.
+FTS=n	Stop Transmission and Wait	n = 0	Stop Transmission and Wait. +FTS=n causes the modem to terminate a transmission. After termination the modem waits for n 10–ms intervals before responding with the OK result code. An ERROR response code results if this command is issued while the modem is on-hook.
+FRS=n	Receive Silence	n = 0	Receive Silence. +FRS=n causes the modem to report back to the DTE with an OK result code after n 10-millisecond intervals of silence have been detected on the line. This command is aborted if any command character is received. The modem discards the aborting character and issues an OK result code. An ERROR response code results if this command is issued while the modem is on-hook.

Table 4-3. Fax Command Set Summary (2 of 2)

Fax Command	Function	Default	Parameters/Description
+FTM=n	Transmit Data	n = 48	Transmit Data. +FTM=n causes the modem to transmit data using the modulation defined below. An ERROR response code results if this command is issued while the modem is on-hook. +FTM=24 V.27 ter 2400 bps +FTM=48 V.27 ter 4800 bps +FTM=72 V.29 7200 bps +FTM=96 V.29 9600 bps
+FRM=n	Receive Data	n = 48	Receive Data. +FRM=n causes the modem to enter the receiver mode using the modulation defined below. An ERROR response code results if this command is issued while the modem is on-hook. +FRM=24 V.27 ter 2400 bps +FRM=48 V.27 ter 4800 bps +FRM=72 V.29 7200 bps (Not supported ⁽¹⁾) +FRM=96 V.29 9600 bps (Not supported ⁽¹⁾)
+FTH=n	Transmit Data with HDLC Framing	n = 3	Transmit Data with HDLC Framing. +FTH=n causes the modem to transmit data framed in HDLC protocol using the modulation defined below. An ERROR response code results if this command is issued while the modem is on-hook. +FTH=3 V.21 Channel 2300 bps
+FRH=n	Receive Data with HDLC Framing	n = 0	Receive Data with HDLC Framing. +FRH=n causes the modem to receive frames in HDLC protocol using the modulation defined below. An ERROR response code results if the command is issued while the modem is on-hook. +FRH=3 V.21 Channel 2300 bps
+FRTn	Receive Test Data	n = 48	Receive Test Data. +FRTn causes the modem to go off-hook and begin demodulating received data at the specified rate. n Configuration/Data Rate n = 24 V.27 ter 2400 bps n = 48 V.27 ter 4800 bps
+FTTn = m	Transmit Test Data	n = 96 m = 0	Transmit Test Data. +FTTn = m causes the modem to transmit a continuous test pattern at the specified rate. The transmission will terminate by a DTE abort (i.e., any character recognized at the DTE interface). n Configuration/Data Rate n = 24 V.27 ter 2400 bps n = 48 V.27 ter 4800 bps n = 72 V.29 7200 bps n = 96 V.29 9600 bps m Test Pattern m = 0 ASCII data (20h - 7Fh sequential) m = 1 All zeros m = 2 All ones m = 3 Alternate 10 m = 4 Sliding 0 (01111) m = 5 Sliding 1 (00001)
NOTE(S): ⁽¹⁾ Modem will respond with ERROR result code.			

5.0 S Registers

The S register commands are summarized in [Table 5-1](#). The range of possible values and the factory default value for each S register are also shown. The factory default values are used whenever the &F command is received or a parity error is detected in the NVRAM upon modem power turn-on.

The user-defined S registered default values are used at modem power turn-on or when a modem reset is received. If the NVRAM is not available or contains a parity error, the factory default S register values are used.

The S registers are described in [Table 5-2](#).

Reading an S Register

The command Sn? reads the current value of an S register, where “n” is the decimal number of the register.

Example: To read the current value in register S0 (Ring to Answer On) and S7 (Wait Time for Data Carrier), perform the following:

Enter: AT S0? S7? (Value in register S0? Value in register S7?)

A typical response to the might be:

Result: 001 (modem will answer on first ring)

Result: 030 (modem will wait 30 seconds for a carrier)

Result: OK (command completed)

勝特力材料 886-3-5753170
勝特力电子(上海) 86-21-54151736
勝特力电子(深圳) 86-755-83298787
[Http://www.100y.com.tw](http://www.100y.com.tw)

Table 5-1. S Register Summary

Register	Range	Units	Default	Description
S0 ⁽¹⁾	0-255	Rings	00	Rings to Auto-Answer
S1	0-255	Rings	00	Ring Counter
S2	0-127	ASCII	43	Escape Character
S3	0-127	ASCII	13	Carriage Return Character
S4	0-127	ASCII	10	Line Feed Character
S5	0-32, 127	ASCII	08	Backspace Character
S6	2-255	Seconds	02	Maximum time to Wait for Dial Tone
S7	1-255	Seconds	30	Wait for Carrier
S8	0-255	Seconds	02	Pause Time for Comma
S9	1-255	1/10 seconds	06	Carrier Detect Response Time
S10	1-255	1/10 seconds	14	Carrier Loss Disconnect Time
S11	50-255	ms	95	DTMF Dialing Speed
S12	0-255	1/50 seconds	50	Escape Prompt Delay
S14 ⁽¹⁾	Bit Mapped	None	AA hex	General Bit Mapped Options
S16	Bit Mapped	None	00	Test Mode Bit Mapped Options (&T)
S17	0-250	4 ms increments	00	Fax Mode Null Byte Timer
S18 ⁽¹⁾	0-255	Seconds	00	Test Timer
S19	0-1	None	00	Conexant Protocol Interface Speed
S20	0-127	Seconds	00	Fax Mode Inactivity Timer
S21 ⁽¹⁾	Bit Mapped	None	00	General Bit Mapped Options
S22 ⁽¹⁾	Bit Mapped	None	76 hex	General Bit Mapped Options
S23 ⁽¹⁾	Bit Mapped	None	07	General Bit Mapped Options
S24	0-255	Seconds	00	Sleep Inactivity Timer
S25 ⁽¹⁾	0-255	0.1 or 1 seconds	05	Delay to DTR Off
S26 ⁽¹⁾	0-255	0.01 seconds	1	RTS-to-CTS Delay
S27 ⁽¹⁾	Bit Mapped	None	40 hex	General Bit Mapped Options
S28 ⁽¹⁾	Bit Mapped	None	00	General Bit-Mapped Options
NOTE(S): ⁽¹⁾ Register value may be stored in one of two user profiles with the AT&W command.				

Table 5-2. S Register Description (1 of 8)

Register	Default	Range	Units	Description
S0	00	0-255	Rings	Ring to Answer On. Assigning S0 a value from 1 to 255 places the modem in auto-answer mode. The modem will auto answer after the specified number of rings has occurred. Setting S0 to 0 disables auto-answer.
S1	00	0-255	Rings	Ring Count. S1 is incremented each time a ring is detected. It will be cleared if no ring occurs within 8 seconds after the last ring.
S2	43	0-127	ASCII	Escape Code Character. S2 holds the ASCII value used for the escape code. The + character responds to the factory default value. Values greater than 127 disable the escape code operation. To enter the command mode when the escape code is disabled, a loss of carrier must occur or DTR must be set to a 0 (dependent on &D command).
S3	13	0-127	ASCII	Carriage Return Character. S3 holds the ASCII value for the carriage return; 13 is the standard value. The character in S3 is both the command line terminator and the result code terminator.
S4	10	0-127	ASCII	Line Feed Character. S4 holds the ASCII value for the line feed. The line feed character is output after the carriage return only when English word result codes have been selected (V1). If a line feed character is not desired, it may be changed to a null, but it cannot be totally disabled.
S5	08	0-32, 127	ASCII	Backspace Character. S5 holds the ASCII value for the backspace character. This character is both the backspace key and the character echoed to move the cursor back one position. Normally a value of 8 is used. The backspace character must not be set to a value corresponding to a printable ASCII character (i.e., between 33 and 126) or to a value greater than 127. A backspace is used as follows: The keystroke is echoed back to the terminal and the cursor moved back over the last character entered. The last character in the command buffer is deleted.
S6	02	2-255	Seconds	Wait for Dial Tone. S6 specifies the wait time before dialing. The delay allows time for the dial tone to occur on the telephone line. The minimum time is 2 seconds. Values greater than 2 seconds may be necessary if trouble is encountered getting dial tones.
S7	30	1-255	Seconds	Wait for Carrier After Dial. S7 specifies the delay time that the modem waits for the carrier signal from the remote modem before hanging up. Typically, a delay time of 30 seconds is enough, but it can be extended to 255 seconds. If the carrier is not detected within the specified time period, the modem hangs up and sends the NO CARRIER result code. If carrier is detected, the modem returns the CONNECT result code and goes on-line.

Table 5-2. S Register Description (2 of 8)

Register	Default	Range	Units	Description
S8	02	0–255	Seconds	Pause Time for the Comma Dial Modifiers. S8 sets the pause time for the comma dial modifier. The comma is used during dialing when it is necessary to dial through a PBX and wait for a second dial tone. A 2-second delay is usually enough. S8 can be changed or multiple commas can be used to lengthen the delay.
S9	06	1–255	1/10 seconds	Carrier Detect Response Time. S9 sets the carrier detect response time.
S10	14	1–255	1/10 seconds	Lost Carrier to Hang Up Delay. S10 sets the delay time between loss of carrier and hang-up. The modem will not hang-up due to loss of carrier if the value of S10 is 255.
S11	95	50–255	ms	DTMF Dialing Speed. S11 sets the duration and inter-digit delay of the touch-tones.
S12	50	0–255	1/50 seconds	Escape Code Guard Time. S12 sets the escape code guard time.
S13	—	—	—	Reserved
S14	AAh	Bit Mapped	None	<p>General Bit Mapped Options. S14 is the modem option register with the following bit functions.</p> <p>Bit 0 Reserved</p> <p>Bit 1 Command Echo (See E command)</p> <p>0 E0—No echo</p> <p>1 E1—Echo (factory default)</p> <p>Bit 2 Results Code (See Q command)</p> <p>0 Q0—Enabled (factory default)</p> <p>1 Q1—Disabled</p> <p>Bit 3 Verbose Command (See V command)</p> <p>0 V0—Digits</p> <p>1 V1—Words (factory default)</p> <p>Bit 4 Reserved</p> <p>Bit 5⁽¹⁾ Dial Method (See T and P commands)</p> <p>0 T—Tone dial</p> <p>1 P—Pulse dial (factory default)</p> <p>Bit 6 Reserved</p> <p>Bit 7 Originate/Answer (See A, D, and R commands, and register S0)</p> <p>0 Answer</p> <p>1 Originate (factory default)</p>
S15	—	—	—	Reserved

勝特力材料 886-3-5753170
 勝特力电子(上海) 86-21-54151736
 勝特力电子(深圳) 86-755-83298787
[Http://www.100y.com.tw](http://www.100y.com.tw)

Table 5-2. S Register Description (3 of 8)

Register	Default	Range	Units	Description
S16	00	—	None	Modem Test Option. Controls the diagnostic modes as follows: Bit 0 Local Analog Loopback L3 (See &T1 command) 0 Disabled (factory default) 1 &T1—Enabled Bit 1 Reserved Bit 2 Local Digital Loopback (See &T3 command) 0 Disabled (factory default) 1 &T3—Enabled Bit 3 Remote Digital Loopback L2 (See &T6 command) 0 Disabled (factory default) 1 &T6—Enabled
S17	00	0-250	4 ms Increments	Fax Mode Null Byte Timer. The value of S17 determines the length of time null bytes are sent by the modem if the last byte sent during DTE underrun in Fax Mode is not a null byte. $0 \leq S17 \leq 250$ corresponds to a timer value of 0–1 second (i.e., the timer value is the value of S17 times 4 ms).
S18	00	0-255	Seconds	Test Timer. Sets the length of time the modem conducts a test before returning to the command mode. If this register is zero, the test will not automatically terminate; the test must be terminated from the command mode by issuing an AT&T0 or ATH command.
S19	—	—	—	Not Supported
S20	0	1-127	Seconds	Fax Mode Inactivity Timer. S20 can be used to cause the modem to automatically place the telephone on-hook or reset itself if inactivity (of variable duration) is detected while in Fax Mode.

勝特力材料 886-3-5753170
 勝特力电子(上海) 86-21-54151736
 勝特力电子(深圳) 86-755-83298787
[Http://www.100y.com.tw](http://www.100y.com.tw)

Table 5-2. S Register Description (4 of 8)

Register	Default	Range	Units	Description
S21	00	Bit Mapped	—	<p>Bit Mapped Options. S21 is the modem register with the following bit functions:</p> <p>Bit 0 Telco Jack (See &J Command)</p> <p>0 &J0—11/RJ-45S (factory default)</p> <p>1 &J1—RJ-12/RJ-13</p> <p>Bit 1 Reserved</p> <p>Bit 2 Ready to Send (RTS)/Clear to Send (CTS). (See &R Command)</p> <p>0 &R0—CTS tracks RTS (not supported)</p> <p>1 &R1—RTS is ignored (factory default)</p> <p>Bit 3, 4 Data Terminal Ready (DTR) (See &D Command)</p> <p>4 3</p> <p>0 0 &D0—Modem ignores DTR (factory default)</p> <p>0 1 &D1—Modem goes to command state if ON-to-OFF transition on DTR</p> <p>1 0 &D2—Modem “hangs up” if ON-to-OFF transition on DTR</p> <p>1 1 &D3—Modem goes to initialization state if ON-to-OFF transition on DTR</p> <p>Bit 5 Data Carrier Detect (DCD) (See &C Command)</p> <p>0 &C0—DCD is always on (factory default)</p> <p>1 &C1—An ON condition on DCD indicates the presence of a valid data carrier</p> <p>Bit 6 Data Set Ready (DSR) (See &S Command)</p> <p>0 &S0—DSR is always on</p> <p>1 &S1—DSR is turned on at the start of handshaking</p> <p>Bit 7 Long Space Disconnect (See Y Command)</p> <p>0 &Y0—Disabled (factory default)</p> <p>1 &Y1—Enabled</p>

勝特力材料 886-3-5753170
 勝特力电子(上海) 86-21-54151736
 勝特力电子(深圳) 86-755-83298787
[Http://www.100y.com.tw](http://www.100y.com.tw)

Table 5-2. S Register Description (5 of 8)

Register	Default	Range	Units	Description
S22	76h	Bit Mapped	—	<p>Bit Mapped Options. S22 is the modem register with the following bit functions:</p> <p>Bit 0, 1 Speaker Volume (See L Command)</p> <p>1 0</p> <p>0 0 L0—Speaker volume low</p> <p>0 1 L1—Speaker volume low</p> <p>1 0 L2—Speaker volume medium (factory default)</p> <p>1 1 L3—Speaker volume high</p> <p>Bit 2, 3 Speaker Control (See M Command)</p> <p>3 2</p> <p>0 0 M0—Speaker disabled</p> <p>0 1 M1—Speaker on until carrier detected (factory default)</p> <p>1 0 M2—Speaker always on</p> <p>1 1 M3—Speaker on until carrier detected but off during dialing</p> <p>Bit 4, 5, 6 Result Code Options (See X Command)</p> <p>6 5 4</p> <p>0 0 0 X0—Selects appropriate connect result code, goes off-hook when the dial command is received, waits the number of nds given by register S6, and “blind dials” (does not look for dial tone).</p> <p>0 0 1 Reserved</p> <p>0 1 0 Reserved</p> <p>0 1 1 Reserved</p> <p>1 0 0 X1—Selects appropriate connect result code, goes off-hook, waits the number of seconds specified by register S6 and blind dials without waiting for dial tone. Busy is not detected.</p> <p>1 0 1 X2—Selects appropriate connect result code, goes off-hook, and dials when dial tone is detected. Busy is not detected.</p> <p>1 1 0 X3—Selects appropriate connect result code, goes off-hook, waits the number of seconds specified in register S6, blind dials, detects busy signal and sends BUSY result code.</p> <p>1 1 1 X4—Selects appropriate connect result code, goes off-hook and dials when dial tone is detected, detects busy signal and sends BUSY result code. All result codes are enabled (factory default).</p> <p>Bit 7 Make/Break Ratio (See &P Command)</p> <p>0 &P0—39/61 United States/Canada (factory default)</p> <p>1 &P1—33/67 UK/Hong Kong</p>

勝特力材料 886-3-5753170
 勝特力电子(上海) 86-21-54151736
 勝特力电子(深圳) 86-755-83298787
[Http://www.100y.com.tw](http://www.100y.com.tw)

Table 5-2. S Register Description (6 of 8)

Register	Default	Range	Units	Description
S23	07	Bit Mapped	—	<p>Bit Mapped Options.</p> <p>Bit 0 Obey request from remote modem for a Remote Digital Loopback (See &T4 and &T5 Commands)</p> <p>0 &T5 selected—RDL disabled</p> <p>1 &T4 selected—RDL enabled (factory default)</p> <p>Bit 1, 2 Communications Rate</p> <p>2 1</p> <p>0 0 300 bps</p> <p>0 1 Reserved</p> <p>1 0 1200 bps</p> <p>1 1 2400 bps (factory default)</p> <p>Bit 3 Reserved</p> <p>Bit 4, 5 Parity Option</p> <p>5 4</p> <p>0 0 Even parity (factory default)</p> <p>0 1 Space parity</p> <p>1 0 Odd parity</p> <p>1 1 Mark/None parity</p> <p>Bit 6, 7 Guard Tones (See &G Command)</p> <p>7 6</p> <p>0 0 &G0—Guard tone disabled (factory default)</p> <p>0 1 Reserved</p> <p>1 0 &G2—1800 Hz guard tone</p> <p>1 1 Reserved</p>
S24	00	0-255	Seconds	<p>Sleep Mode Inactivity Timer. S24 is used to set the amount of time the modem may be inactive before it will enter sleep mode. The range of S24 is $0 \leq S24 \leq 4$, and Sleep Mode is inhibited when $S24 = 255$. (Also see Sleep Mode Signals in Table 3-5.)</p>
S25	05	0-255	0.01 or 1 Seconds	<p>Detect DTR Change. If &Q1 is selected, S25 is the delay in seconds after a connection has been made, but before the modem examines the DTR lead.</p> <p>If in the on-line or on-line command state, changes in DTR that last less than the time specified by S25, in 0.01 sec increments, are ignored by the modem.</p>
S26	01	0-255	0.01 Seconds	<p>RTS to CTS Delay Intervals. Reserved</p>

勝特力材料 886-3-5753170
 勝特力电子(上海) 86-21-54151736
 勝特力电子(深圳) 86-755-83298787
[Http://www.100y.com.tw](http://www.100y.com.tw)

Table 5-2. S Register Description (7 of 8)

Register	Default	Range	Units	Description
S27	40h	Bit Mapped	—	<p>Bit Mapped Options.</p> <p>Bit 3, 1, 0 Communications Mode Option (See &D Command)</p> <p>3 1 0</p> <p>0 0 0 &Q0 selected—Asynchronous (factory default)</p> <p>0 0 1 &Q1 selected—Synchronous (not supported)</p> <p>0 1 0 &Q2 selected—Synchronous (not supported)</p> <p>0 1 1 &Q3 selected—Synchronous (not supported)</p> <p>1 0 0 Reserved</p> <p>1 0 1 Reserved</p> <p>1 1 0 Reserved</p> <p>1 1 1 Reserved</p> <p>Bit 2 Dial Up/Leased Line Option</p> <p>0 Dial Up (factory default)</p> <p>1 Leased Line (not supported)</p> <p>Bit 4, 5 Synchronous Transmit Clock Source Selection (See &X Command)</p> <p>5 4</p> <p>0 0 &X0—Internal Clock (factory default)</p> <p>0 1 &X1—External DTE Clock (not supported)</p> <p>1 0 &X2—Receive Clock (not supported)</p> <p>1 1 Reserved</p> <p>Bit 6 Communications Standard Option (See B Command)</p> <p>0 B0—CCITT V.22 bis/V.22</p> <p>1 B1—Bell 212A (factory default)</p> <p>Bit 7 Data/Fax Discrimination (i.e., AT+FAA Status)</p> <p>0 Data/Fax auto answer mode disabled (AT+FAA = 0)</p> <p>1 Data/Fax auto answer mode enabled (AT+FAA = 1)</p>

勝特力材料 886-3-5753170
 勝特力电子(上海) 86-21-54151736
 勝特力电子(深圳) 86-755-83298787
[Http://www.100y.com.tw](http://www.100y.com.tw)

Table 5-2. S Register Description (8 of 8)

Register	Default	Range	Units	Description																																												
S28	00	Bit Mapped	—	<p>Bit Mapped Options.</p> <p>Bit 2, 1, 0 Transmit Level Attenuation (See %Ln Command)</p> <table border="0"> <tr> <td>2 1 0</td> <td>Description</td> </tr> <tr> <td>0 0 0</td> <td>0 dB attenuation</td> </tr> <tr> <td>0 0 1</td> <td>2 dB attenuation</td> </tr> <tr> <td>0 1 0</td> <td>4 dB attenuation</td> </tr> <tr> <td>0 1 1</td> <td>6 dB attenuation</td> </tr> <tr> <td>1 0 0</td> <td>8 dB attenuation</td> </tr> <tr> <td>1 0 1</td> <td>10 dB attenuation</td> </tr> <tr> <td>1 1 0</td> <td>12 dB attenuation</td> </tr> <tr> <td>1 1 1</td> <td>14 dB attenuation</td> </tr> </table> <p>Bit 5, 4, 3 DTMF Transmit Level Attenuation (See %Dn Command)</p> <table border="0"> <tr> <td>5 4 3</td> <td>Description</td> </tr> <tr> <td>0 0 0</td> <td>0 dB attenuation</td> </tr> <tr> <td>0 0 1</td> <td>2 dB attenuation</td> </tr> <tr> <td>0 1 0</td> <td>4 dB attenuation</td> </tr> <tr> <td>0 1 1</td> <td>6 dB attenuation</td> </tr> <tr> <td>1 0 0</td> <td>8 dB attenuation</td> </tr> <tr> <td>1 0 1</td> <td>10 dB attenuation</td> </tr> <tr> <td>1 1 0</td> <td>12 dB attenuation</td> </tr> <tr> <td>1 1 1</td> <td>14 dB attenuation</td> </tr> </table> <p>Bit 6 Dialing Pulses per Second</p> <table border="0"> <tr> <td>0</td> <td>10 pps</td> </tr> <tr> <td>1</td> <td>20 pps</td> </tr> </table> <p>Bit 7 Secondary Defaults (See %J Command)</p> <table border="0"> <tr> <td>0</td> <td>&F defaults</td> </tr> <tr> <td>1</td> <td>%J defaults</td> </tr> </table>	2 1 0	Description	0 0 0	0 dB attenuation	0 0 1	2 dB attenuation	0 1 0	4 dB attenuation	0 1 1	6 dB attenuation	1 0 0	8 dB attenuation	1 0 1	10 dB attenuation	1 1 0	12 dB attenuation	1 1 1	14 dB attenuation	5 4 3	Description	0 0 0	0 dB attenuation	0 0 1	2 dB attenuation	0 1 0	4 dB attenuation	0 1 1	6 dB attenuation	1 0 0	8 dB attenuation	1 0 1	10 dB attenuation	1 1 0	12 dB attenuation	1 1 1	14 dB attenuation	0	10 pps	1	20 pps	0	&F defaults	1	%J defaults
2 1 0	Description																																															
0 0 0	0 dB attenuation																																															
0 0 1	2 dB attenuation																																															
0 1 0	4 dB attenuation																																															
0 1 1	6 dB attenuation																																															
1 0 0	8 dB attenuation																																															
1 0 1	10 dB attenuation																																															
1 1 0	12 dB attenuation																																															
1 1 1	14 dB attenuation																																															
5 4 3	Description																																															
0 0 0	0 dB attenuation																																															
0 0 1	2 dB attenuation																																															
0 1 0	4 dB attenuation																																															
0 1 1	6 dB attenuation																																															
1 0 0	8 dB attenuation																																															
1 0 1	10 dB attenuation																																															
1 1 0	12 dB attenuation																																															
1 1 1	14 dB attenuation																																															
0	10 pps																																															
1	20 pps																																															
0	&F defaults																																															
1	%J defaults																																															
<p>NOTE(S):</p> <p>(1) Bit 5 is set or reset if the dial command string contains a P (pulse dial) or T (tone dial), respectively. If a subsequent dial command string is used with a P or T, the modem uses the option specified by this bit.</p>																																																

勝特力材料 886-3-5753170
 勝特力电子(上海) 86-21-54151736
 勝特力电子(深圳) 86-755-83298787
[Http://www.100y.com.tw](http://www.100y.com.tw)

6.0 Operation

Modem operation supports data modem processing, fax modem processing and common call progress processing.

The AT+FCLASS command allows the operator to select either data or fax operation.

AT+FCLASS=0 Data mode
 AT+FCLASS=1 Fax mode Class 1

6.1 Data Modes

6.1.1 Data Mode Selection

Data mode operation is defined by the AT commands and S register settings described in Chapter 4 and Chapter 5. Data rate selection is determined by the speed of the originating and answering modems as listed in [Table 6-1](#).

Table 6-1. Data Rate Selection

Answer Mode	Originate Mode		
	300	1200	2400
300	300	1200	1200
1200	300	1200	1200
2400	300	1200	2400

6.1.2 Data Modem Processing

Data modem processing is explicitly defined in CCITT V.22 bis, CCITT V.22, Bell 212A, and Bell 103 documentation. All modulation, waveform spectrum, and data processing functions conform to the appropriate specifications with the following exceptions:

1. CTS is ON all the time and does not go OFF during handshake.
2. DSR is always ON in parallel mode operation.
3. The rate change request option is not supported for V.22 bis.
4. V.22 operation supports only Alternative B, mode ii (1200 bps asynchronous, 10 bit characters)

6.1.3 Call Origination

Automatic and manual origination of calls is supported. Automatic call origination is supported by the ATDS command. The modem automatically enters the data handshaking mode upon completion of the dial function.

6.1.4 Call Answering

Automatic and manual answering of calls is supported. Incoming ring signals are detected by the modem and indicated by the RING result code. Answering can be performed by the DTE acknowledging the RING result code and issuing the ATA command or by having the modem automatically go off-hook after N rings are detected. The number of rings, N, is determined by the setting of the S0 register. Upon going off-hook, the DCE will transmit 2100 Hz (or 2225 Hz for Bell modes) for a duration of not less than 2.6 seconds and not more than 4.0 seconds.

6.1.5 Call Termination

A call is terminated by the DTE sending the ATH command to the modem.

勝特力材料 86-3-5753170
勝特力电子(上海) 86-21-54151736
勝特力电子(深圳) 86-755-83298787
[Http://www.100y.com.tw](http://www.100y.com.tw)

6.2 Fax Modes

6.2.1 Fax Mode Selection

Fax modes and rates are determined by the AT+F commands and are defined in [Chapter 4.0, AT Commands](#).

6.2.2 Fax Mode Processing

Fax modem processing is explicitly defined in CCITT V.29, CCITT V.27 ter, and CCITT V.21 recommendations. All modulation, waveform spectrum, and data processing functions conform to the appropriate specifications with the following exceptions:

1. V.29 receive functions are not supported.
2. V.29 4800 bps is not supported; V.27 ter 4800 bps is used instead.
3. V.29 half-duplex continuous carrier mode only is supported.
4. V.29 channel multiplexer option is not supported.
5. V.27 ter 75-baud backward channel option is not supported.
6. V.27 ter short train mode is not supported.

6.2.3 Fax Origination

Automatic origination of fax call is supported by the ATDS command. Upon completion of the dial function, a calling tone at 1100 Hz (± 38 Hz) with an ON duration of 0.5 seconds (± 75 ms) and OFF duration of 3 seconds (± 450 ms) is transmitted.

6.2.4 Fax Answering

Answering of fax calls is identical to answering of data calls, with the exception that the DCE enters the fax handshaking mode instead of the data handshaking mode after going off-hook.

勝特力材料 886-3-5753170
勝特力电子(上海) 86-21-54151736
勝特力电子(深圳) 86-755-83298787
[Http://www.100y.com.tw](http://www.100y.com.tw)

6.2.5 Fax Data Transmission

Fax data transmission is initiated by the +FTM command. Upon recognition of the command, the modem initiates the selected modulation mode and issues the CONNECT result code. The proper training sequence for the selected mode is transmitted, followed by constant 1 bits, until data is received from the DTE. DTE data is buffered and processed prior to being transmitted. The transmission is terminated when the transmit buffer becomes empty and the last transmitted character was not a NUL character. The modem then turns off the carrier and issues the OK result code. If the last character was a NUL character (00), the modem continues to transmit NUL characters until more data is received by the DTE or until 5 seconds have elapsed. After 5 seconds, the modem turns off the carrier and issues the ERROR result code.

6.2.6 Fax Data Reception

Fax data reception is initiated by the +FRM command. Upon recognition of the command, the modem initiates the selected demodulation mode and looks for the proper carrier. When the selected carrier is detected, the modem issues the CONNECT result code +FCERROR. If a signal other than the selected carrier is detected, the modem returns to the command state. Demodulated data is stored in an output buffer for additional I/O processing and eventual output to the DTE. Detection of loss of carrier will cause the modem to issue the NO CARRIER result code and will cause the modem to return to the command state. Any character other than flow control characters issued while the receiver is outputting data will cause the receiver to abort and return to the command state.

6.2.7 Fax Control Transmission

Fax control transmission is initiated by the +FTH command or after answering a call. The modem initiates the selected modulation mode, issues the CONNECT result code, transmits one second of flags, then transmits data sent by the DTE. DTE data is buffered and processed prior to transmission.

Processed I/O data is grouped into frames and encoded with a CRC generator. The generator polynomial is $X^{16} + X^{12} + X^5 + 1$. The CRC parity or frame check sequence (FCS) is appended to the end of the frame. The end of the frame is indicated by an empty I/O buffer. Transmission frames begin and end with a flag sequence (7Eh). The ending flag may serve as the beginning flag for the next frame. To prevent data from looking like flags, a 0 is inserted into the data stream after five consecutive 1s are detected.

勝特力材料 886-3-5753170
勝特力电子(上海) 86-21-54151736
勝特力电子(深圳) 86-755-83298787
[Http://www.100y.com.tw](http://www.100y.com.tw)

Each frame is checked to see if the current frame is the last frame of the transmission. If the final frame bit (5th received bit of the second byte of the frame) is 1, indicating that the current frame is the final frame, the modem completes the frame transmission, issues the OK result code, and returns to the command state. If the final frame bit is a 0, the modem issues the CONNECT result code and continues to transmit flags until one of the following actions is taken by the DTE:

1. If additional data is sent by the DTE, the modem transmits another frame.
2. If the transmission is terminated by the <DLE> <ETX> string, the modem turns off the carrier and issues the OK result code.
3. If no data is sent by the DTE within 5 seconds of receiving the CONNECT message, the modem turns off the carrier and issues the ERROR result code.

6.2.8 Fax Control Reception

Fax control reception is initiated by the +FRH command or after dialing. Upon recognition of the command, the modem initiates the selected demodulation mode and looks for the proper carrier. When the selected carrier is detected, the modem issues the CONNECT result code. If a signal other than the selected carrier is detected, the modem issues an +FCERROR result code and returns to the command state.

The modem removes the flags, removes transmitter inserted 0 bits (a 0 following five consecutive 1s), performs the CRC error checking, and stores the data in the internal I/O buffer for further processing and eventual passing to the DTE.

The modem indicates the end of a frame by issuing the <DLE> <ETX> characters and an OK result code if the frame was received correctly, or by issuing an ERROR result code if one or more errors were detected in the frame. The first frame received is stripped of flags (CONNECT result code indicates that a valid flag has been received) and output to the DTE. Subsequent frames are buffered and output to the DTE when additional +FRH commands are received.

Any characters other than flow control that are received while demodulating data and prior to issuance of the status result code will result in the receive process being aborted, an OK result code being issued, and the modem returning to the command state. After the status result code is issued, the modem continues to demodulate data. Additional +FRH commands specifying the same modulation rate will result in the issuance of a CONNECT result code, output of the next data frame, and continuation of normal demodulation. Any other commands will result in the receive process being aborted, buffered data being discarded, and the command being implemented.

Detection of loss of carrier will result in the modem issuing the NO CARRIER result code and returning to the command state.

6.2.9 Fax I/O Processing

The fax I/O interface supports asynchronous serial and parallel interfaces. The interface rate is 19.2 kbps. Start and stop elements are removed from the incoming serial data stream and are added to the outgoing serial data (receive).

勝特力材料 886-3-5753170
 勝特力电子(上海) 86-21-54151736
 勝特力电子(深圳) 86-755-83298787
[Http://www.100y.com.tw](http://www.100y.com.tw)

Both transmit and receive data are buffered. Flow control using X-on/X-off (DC1/DC3) is provided.

Unique control character strings are identified, filtered, or reinserted into the I/O data stream. These control characters and their resultant action are shown below.

DTE to Modem Transmit Data Stream

<DLE> <data>	Delete <DLE> <data> characters.
<DLE> <ETX>	Recognize as a string terminator and take appropriate action.
<DLE> <DLE>	Replace with single <DLE> character.

Modem to DTE Receive Data Stream

<DLE>	Insert extra <DLE> ahead of <DLE>
-------	-----------------------------------

The modem also identifies the end of a frame by inserting <DLE> <ETX> into the data stream after the FCS bytes.

勝特力材料 886-3-5753170
 勝特力电子(上海) 86-21-54151736
 勝特力电子(深圳) 86-755-83298787
[Http://www.100y.com.tw](http://www.100y.com.tw)

6.3 Fax Enhanced Flow Control

The fax Class 1 standard provides for bidirectional X-on/X-off flow control. However, in multitasking “windowing” environments, the DTE communication package can be suspended long enough to miss a 19,200 bps serial asynchronous character sent by the DCE (520.83 μ s). X-on/X-off flow control will not solve this problem because the DTE software does not always know when it is going to be suspended. To solve this problem, a new enhanced flow control mechanism is provided. This mechanism is enabled/disabled by issuing an AT+FF=1/0 command.

6.3.1 Parallel/Serial Interface Selection

For parallel host interface operation, the enhanced flow control takes advantage of the fact that the DCE hardware knows if the DTE has read the last character. The DCE will not send a new character until the DTE reads the previous one. The modem fax receiver has an internal 223-byte buffer. Therefore, the DTE can stop reading characters for 371 ms (4800 bps receive) before any data is lost.

For serial interface operation, the enhanced flow control mechanism utilizes the fact that the Fax Class 1 serial interface is only required to operate half duplex. The scheme involves sending characters to the DTE and waiting for the DTE to send an acknowledgment (if the DTE reads the character OK) or a request for re-transmission (if the DTE misses a character and detects an overrun). The required DTE operation using the enhanced flow control mechanism is defined below.

6.3.2 Fax V.42 Buffer Sizes

Fax V.42 buffer sizes are shown below.

Buffer Type	Size in Bytes
Fax V.27/V.29 Tx	255 (9600:212 ms)
Fax V.21 (HDLC) Tx	255 (300:6.8 sec)
RPI (HDLC) Tx	238 (2400:793 ms)
Fax V.27 Rx	223 (4800:371 ms)
Fax V.21 (HDLC) Rx	255 (300:6.8 sec)

勝特力材料 886-3-5753170
 勝特力电子(上海) 86-21-54151736
 勝特力电子(深圳) 86-755-83298787
[Http://www.100y.com.tw](http://www.100y.com.tw)

6.3.3 DTE Flow Control Operation

Normal operation: DTE does not miss character. The DTE reads the serial character sent by the DCE. The DTE checks serial hardware overrun status and determines that an overrun did not occur. The DTE can therefore use the character. The DTE must send the following acknowledgment character back to the DTE.

11111110 (FEh)

Overrun Operation: DTE misses character. The DTE returns after being suspended and reads the serial character sent by the DCE. The DTE checks serial hardware overrun status and determines that an overrun occurred. The DTE does not use the received character. The DTE then sends the following re-transmission request character back to the DCE.

11110000 (F0h)

勝特力材料 886-3-5753170
勝特力电子(上海) 86-21-54151736
勝特力电子(深圳) 86-755-83298787
[Http://www.100y.com.tw](http://www.100y.com.tw)

6.4 Data/Fax Auto Answering

Data/fax auto answering, when used with appropriate DTE host software, will automatically recognize whether an incoming call is a data or fax modem. This mechanism can be used with an integrated data/fax communication package or with separate data/fax communication packages operating together in a foreground/background configuration.

The auto answering mechanism is structured such that the DTE is initially operating in the fax mode. The DTE enables auto answering using the AT+FAA=1 command (saved in NVRAM under S27). This command should be issued while AT+FCLASS=1. The DTE will then change its communication rate from 19,200 bps (fax class 1 rate) to the rate expected in data mode (2400, 1200, or 300 bps).

The DCE will attempt to establish a connection with the incoming call as a data modem. If the incoming call is a fax, the DCE will switch to the fax mode and establish the connection. To minimize incompatibilities with various fax and data modems, the 59 register is used to define the length of time that the DCE has to establish a data connection.

S9 (Range: 0–255; Default: 06) defines the time (in seconds) after going off-hook that the DCE waits for the entire data mode handshaking process to complete before switching to fax mode.

When a call is received (DCE sends RING result code), the DTE can initiate the answer manually by sending an ATA command. Alternatively, the DTE can allow the DCE to answer automatically by setting S0=non-zero value. After the DCE goes off-hook, it will automatically determine the caller type (data or fax),

establish the appropriate connection, and inform the DTE of the caller type with the following result codes:

Numeric	Verbose	Description
13 (0Dh)	DATA	DCE sends this result code only during auto answering or when DCE has connected as a data modem.
15 (0Fh)	FAX	DCE sends this result code only during auto answer mode when DCE has connected as a fax modem.

It is assumed initially for auto answer operation that the DTE is running the fax communication package.

It is impractical to force the fax package to use the same options selected by the data package. Therefore, some method must be provided to allow the DTE fax package to restore the DCEs registers after the DCE has connected as a data modem. The DCE accommodates this by automatically entering the on-line command mode after connecting. After the DTE receives the DATA result code, it can then send any necessary AT commands to the DCE. The DCE will wait in the on-line command mode and delay sending the “data” connect message until the DTE sends an ATO command. After sending the ATO command, the DTE then transfers control to the data communication package.

For DTEs running separate data and fax packages in a foreground/background configuration, a method is provided to allow the fax package to regain control after the data connection has terminated during auto answer mode without requiring changes to existing data packages. The RC224ATLV accommodates this through the use of the data carrier detect (DCD) indicator. Initially, in auto answer mode DCD will be off. When connected in data mode, the DCE will turn DCD on. When the data connection is terminated, the DCE will turn DCD off again. The fax package, running in the background, can poll DCD (160450 modem status register bit 7) to ascertain the data connection status. The DTE must send AT&C1 to cause DCD to operate in this manner.

During auto answer mode, when the caller is a fax machine, the DCE will behave as a normal fax DCE (as defined by +FCLASS=1) with the following exceptions:

1. The transmission of the fax 2100 Hz answer tone will be delayed by the time needed to determine that the caller is a fax machine (S9 seconds).
2. The DCE sends FAX message at the data mode DTE rate (as defined by the previous AT command autobaud rate) and automatically sets +FCLASS=1 after detecting that the caller is a fax.
3. After the answer tone is sent and the DCE enters the V.21 transmit mode, the CONNECT result code will be sent at 19,200.

During auto answer mode, if the DCE determines that the caller is not a data modem nor a fax machine, then DCE will send the NO CARRIER result code, go on-hook and remain in data mode.

Table 6-2 describes a procedure to configure a terminal being called by a 1200 bps data modem. Table 6-3 describes a procedure to configure a terminal being called by a fax machine with or without calling tone.

勝特力材料 886-3-5753170
 勝特力电子(上海) 86-21-54151736
 勝特力电子(深圳) 86-755-83298787
[Http://www.100y.com.tw](http://www.100y.com.tw)

Table 6-2. Terminal Called by a 1200 bps Data Modem

DTE Command	DCE Response	Comments
—	—	Assume DCE in fax mode (FCLASS = 1), DTE running fax communication package, and DCD is off.
AT&C1	OK	DTE commands DCE to follow data carrier.
ATS9=n	OK	DTE defines the data mode connection time.
AT+FAA=1	OK	DTE enables data/fax auto answer mode.
—	—	DTE sets the communication rate to the data modem rate (e.g., 2400 bps) <i>prior to an incoming call.</i>
—	RING	Terminal is being called.
ATA	—	DTE commands DCE to go off-hook and start auto answer.
—	—	DCE determines caller as data modem and establishes connection with caller.
—	—	DCE turns on DCD to indicate data connection is established.
—	—	DCE then waits in on-line command mode.
—	DATA	DCE indicates data modem connection is established.
AT commands	OK	DTE optionally sends any commands to DCE to restore conditions required by data modem communications package.
ATO	CONNECT 1200	DTE instructs DCE to switch from on-line command to data state.
—	—	DTE then transfers control to data modem package.
—	—	Fax package remains in background polling DCD to check connection status.
—	—	DCE response will then be read by data modem communication rate to 1200 bps.
—	"Callers data"	DTE sends/receives data.
—	—	Caller hangs up. DTE detects carrier loss and turns off DCD.
—	NO CARRIER	DCE indicates connection with caller has terminated.
—	—	DTE fax communications software, running in background, sees DCD turn off, and regains control from data modem package.

勝特力材料 886-3-5753170
 勝特力电子(上海) 86-21-54151736
 勝特力电子(深圳) 86-755-83298787
[Http://www.100y.com.tw](http://www.100y.com.tw)

Table 6-3. Terminal Called by a Fax Machine

DTE Command	DCE Response	Comments
—	—	Assume DCE in fax mode (FCLASS = 1), DTE is running fax communication package, and DCD is off.
AT&C1	OK	DTE commands DCE to follow data carrier.
ATS9=n	OK	DTE defines the data mode connection time.
AT+FAA=1	OK	DTE enables data/fax auto answer mode.
—	—	DTE sets the communication rate to the data modem rate (e.g., 2400 bps) <i>prior to an incoming call</i> .
—	RING	Terminal is being called.
ATA	—	DTE commands DCE to go off-hook and start auto answer.
—	—	DCE starts data modem handshaking. If receive data signal is not detected within S9 seconds from going off-hook, DCE switches to fax mode and automatically sets FCLASS=1.
—	FAX	DCE switches to fax mode handshaking and sends "FAX" message at the data modem rate (e.g., 2400 bps).
—	—	DCE sends 3 seconds of 2100 Hz answer tone, enters V.21 transmit mode, and sends HDLC flags.
—	CONNECT	DCE ends CONNECT response at the fax rate (i.e., 19,200 bps).

勝特力材料 886-3-5753170
 勝特力电子(上海) 86-21-54151736
 勝特力电子(深圳) 86-755-83298787
[Http://www.100y.com.tw](http://www.100y.com.tw)

6.5 Call Progress

勝特力材料 886-3-5753170
 勝特力电子(上海) 86-21-54151736
 勝特力电子(深圳) 86-755-83298787
[Http://www.100y.com.tw](http://www.100y.com.tw)

6.5.1 Call Progress Algorithms

Data call progress algorithms measure the power and/or relative power of the highband and lowband channels and determine signal presence and cadence correlations. Highband channel signals include 2100 and 2225 Hz signalling tones. Lowband channel signals include dial tones, busy tones, ringback tones and voice ranging in frequency from 120 to 620 Hz.

Characteristics of the tones detected by the RC224ATLV are listed in [Table 6-4](#).

Table 6-4. Tone Characteristics

Tone	Cadence	Frequency (Hz)
Dial Tone	Continuous	350 + 440
Old Dial Tone	Continuous	600+120/133
Busy	0.5 sec ON 0.5 sec OFF	480 + 620 480 + 620
Old Busy	0.5 sec ON 0.5 sec OFF	600 + 120 600 + 120
Precision Reorder	0.3 sec ON 0.2 sec OFF	480 + 620 480 + 620
Old Reorder (local)	0.25 sec ON 0.25 sec OFF	600 + 120 600 + 120
Old Reorder (toll)	0.2 sec ON 0.3 sec OFF	600 + 120 600 + 120
Ringback	0.8-1.2 sec ON 2.7-3.3 OFF	440 + 480 440 + 480
Old Ringback	2 sec ON 4 sec OFF	420 + 40 420 + 40
Double Ringback	0.8 sec ON 0.3 sec OFF 0.8 sec ON 4 sec OFF	440 + 480 440 + 480 440 + 480 440 + 480

Fax answer tone detection requirements include 2100 and 1100 Hz. The call progress detection requirements are identical to the lowband data signals identified above.

6.5.2 Ring Detection

Ring detection is based on a digital input to the modem. External circuitry not part of the modem is required to convert the analog 40 to 150 V_{RMS} ring signal to a digital single-bit data stream representation. Valid ring frequencies of 15.3 to 68 Hz are detected. Detection is achieved by counting valid high to low ring signal transitions. Valid transitions consist of a high state of 2 to 34 ms followed by a low state of 2 to 42 ms. Ring signals that have transition counts less than the nominal value are discarded.

In addition to valid high to low transitions, ring detection depends on the cadence of the ring ON time (valid transitions occurring) and ring OFF time (no valid transitions). Ring OFF times must be greater than 0.5 seconds. Ring ON times must be greater than 125 ms at 20 Hz (100 ms at 68 Hz).

Ring detection is integrated over 8 seconds. All counters and timers are reset at 8 second intervals. The modem will answer the ring after N valid ON/OFF ring cycles. N is programmable via the S0 register. Upon detecting N rings, the modem verifies that the current ring state has been in the OFF state for 0.5 seconds before seizing the line.

Table 6-5 lists the Fax Class 1 calling sequence; Table 6-6 lists the answering sequence.

Table 6-5. Fax Class 1 Calling Sequence (1 of 2)

DTE Commands (Host)	DCE Responses (Modem)	Remote Fax	Notes
(1) AT+FCLASS=1	(2) OK	—	Set to Class 1
PHASE A			
(3) ATDT6163	(4) Dials (6) CONNECT	(5) Answers (7) Send HDLC flags	+FRH=3 implied by Dialing
PHASE B			
—	—	(8) Send NSF frame	—
—	(9) <NSF>, OK	—	—
(10) AT+FRH=3	(11) CONNECT	—	—
—	—	(12) Send CSI frame	—
—	(13) <CIS>, OK	—	—
(14) AT+FRH=3	(15) CONNECT	—	—
—	—	(16) Send DIS frame	Last frame bit = 1
—	(17) <DIS>, OK	(18) Drop carrier	—
(19) AT+FTH=3	(20) Send HDLC flags	(21) Receive flags	—
—	(21) CONNECT	—	—
(22) <TSI>	(23) Send TSI frame	(24) Receive TSI	Last frame bit = 0
—	(25) CONNECT	—	—
(26) <DCS>	(27) Send DCS frame	(28) Received DCS	Last frame bit = 1
—	(29) Detect last frame bit	—	—

Table 6-5. Fax Class 1 Calling Sequence (2 of 2)

DTE Commands (Host)	DCE Responses (Modem)	Remote Fax	Notes
—	(30) OK, drop carrier	—	—
(31) AT+FTS=8	(32) OK, wait 80 ms	—	—
(33) AT+FTM=96	(34) Send F.29	—	—
—	(35) CONNECT	—	—
(36) <TCF>	(37) Send TCF data	(38) Receive and check	—
—	(39) OK	—	—
(40) AT+FRH=3	(41) CONNECT	—	—
—	—	(42) Send CFR frame	Last frame bit = 1
—	(43) <CFR>, OK	(44) Drop carrier	—
—	(45) OK	—	—
PHASE C			
(46) AT+FRM=06	(47) Send V.29	—	—
—	(48) CONNECT	—	—
(49) Page data	(50) Send page data	(51) Receive data	—
—	(52) OK	—	—
(53) AT+FTH=3	(54) Send HDLC flags	(55) Receive flags	—
—	(56) CONNECT	—	—
PHASE D			
(57) <EOP>	(58) Send EOP frame	(59) Receive EOP	Last frame bit = 1
—	(60) OK, drop carrier	—	—
(61) AT+FRH=3	(62) CONNECT	—	—
—	—	(63) Send MCF frame	Last frame bit = 1
—	(64) <MCF>,OK	—	—
(65) AT+FTH=3	(66) Send HDLC flags	(67) Receive flags	—
—	(68) CONNECT	—	—
(69) <DCN>	(70) Send DCN frame	(71) Receive DCN	Last frame bit = 1
—	(72) OK, drop carrier	—	—
PHASE E			
(73) ATH0	(74) OK, hang up	(75) Hang up	—

勝特力材料 886-3-5753170
 勝特力电子(上海) 86-21-54151736
 勝特力电子(深圳) 86-755-83298787
[Http://www.100y.com.tw](http://www.100y.com.tw)

Table 6-6. Fax Class 1 Answering Sequence (1 of 2)

DTE Commands (Host)	DCE Responses (Modem)	Remote Fax	Notes
(1) AT+FCLASS=1	(2) OK	—	Set to Class 1
(2b) AT+FRM=?	24,48	—	—
—	OK	—	—
PHASE A			
—	—	(3) FAX machine dials	—
—	(4) RING	—	—
(5) ATA	(6) Modem answers	—	—
—	(7) Send HDLC flags	(8) Receive flags	+FTH=3 implied by answering
—	(9) CONNECT	—	—
PHASE B			
(10) <NSF>	(11) Send NSF frame	(12) Receive NSF	Last frame bit = 0
—	(13) CONNECT	—	—
(14) <CSI>	(15) Send CSI frame	(16) Receive CSI	Last frame bit = 0
—	(17) CONNECT	—	—
(18) <DSI>	(19) Send DSI frame	(20) Receive DSI	Last frame bit = 1
—	(21) OK, drop carrier	—	—
(22) AT + FRH=3	(23) CONNECT	—	—
—	—	(24) Send TSI frame	Last frame bit = 0
—	(25) <TSI>,OK	—	—
(26) AT+FRH=3	(27) CONNECT	—	—
—	—	(28) Send DCS frame	Last frame bit = 1
—	(29) <DCS>,OK	(30) Drop carrier	—
(31) AT+FTH=3	—	—	—
—	—	(32) Send V.27 (4800)	—
—	(33) CONNECT	(34) Send TCF frame	—
—	(35) <TCF>	(36) Drop carrier	—
—	(37) NO CARRIER	—	—
(38) AT+FRM=48	(39) CONNECT	—	—
(40) <CFR>	(41) Send CFR frame	(42) Receive CFR	Last frame bit = 1
—	(43) OK, drop carrier	—	—

Table 6-6. Fax Class 1 Answering Sequence (2 of 2)

DTE Commands (Host)	DCE Responses (Modem)	Remote Fax	Notes
PHASE C			
(44) AT+FRM=48	—	—	—
—	—	(45) Send page data	—
—	(46) <page data>	(47) Drop carrier	—
—	(48) NO CARRIER	—	—
PHASE D			
(49) AT+FRH=3	(50) CONNECT	—	—
—	—	(51) Send EOP frame	Last frame bit = 1
—	(52) <EOP>, OK	—	—
(53) AT+FTH=3	(54) CONNECT	—	—
(55) <MCF>	(56) Send MCF frame	(57) Receive MCF	Last frame bit = 1
—	(58) OK, drop carrier	—	—
(59) AT+FRH=3	(60) CONNECT	—	—
—	—	(61) Send DCN frame	Last frame bit = 1
—	(62) <DCN>, OK	—	—
PHASE E			
(73) ATH0	(74) OK, hang up	(75) Hang up	—

勝特力材料 886-3-5753170
 勝特力电子(上海) 86-21-54151736
 勝特力电子(深圳) 86-755-83298787
[Http://www.100y.com.tw](http://www.100y.com.tw)

7.0 Electrical/Mechanical Specifications

7.1 Interfacing the RC224ATLV

The RC224ATLV is not 5.0 V I/O logic tolerant. It is recommended that a series resistor of 150 Ω be added to current limit the digital inputs to the RC224ATLV when interfacing to + 5.0 V logic output lines. The digital outputs of the RC224ATLV should not go to resistor pullups that are connected to the + 5 V power supply. These precautions will help prevent the modem chip from going into latchup due to raising any input or output pin level more than + 0.3 V above the + 3.3 V power rail of the RC224ATLV.

7.2 Environmental Requirements

The environmental specifications are listed in [Table 7-1](#).

Table 7-1. Environmental Specifications

Parameter	Specification
Operating Temperature	0 °C to + 70 °C (32 °F to 158 °F)
Storage Temperature	– 55 °C to + 125 °C (– 67 °F to + 257 °F)
Relative Humidity	Up to 90 % noncondensing, or a wet bulb temperature up to 35 °C, whichever is less.

勝特力材料 886-3-5753170
勝特力电子(上海) 86-21-54151736
勝特力电子(深圳) 86-755-83298787
[Http://www.100y.com.tw](http://www.100y.com.tw)

7.3 Interface Timing and Waveforms

Table 7-2 lists the host bus interface timing parameters. Figure 7-1 illustrates the interface waveforms. Table 7-3 lists the current and power requirements, and Table 7-4 lists absolute maximum ratings.

Table 7-2. Timing—Host Bus Interface

Symbol	Parameter	Min	Max	Units
t_{AS}	Address Setup	25	—	ns
t_{AH}	Address Hold	0	—	ns
t_{CS}	Chip Select Setup	10	—	ns
t_{CH}	Chip Select Hold	0	—	ns
t_{RD}	Read Strobe Width	100	—	ns
t_{DD}	Delay \overline{HRD} to Data	—	75	ns
t_{DRH}	\overline{HRD} to Data Hold	10	—	ns
t_{WT}	Write Strobe Width	75	—	ns
t_{DS}	Write Data Setup	30	—	ns
t_{DWH}	Write Data Hold	10	—	ns
t_{DF}	\overline{HRD} to Driver Off	—	30	ns
t_{DIS}	HDIS Enable	—	40	ns
t_{DIH}	HDIS Hold	40	—	ns
t_{INH}	Interrupt Hold	—	100	ns

勝特力材料 886-3-5753170
 勝特力电子(上海) 86-21-54151736
 勝特力电子(深圳) 86-755-83298787
[Http://www.100y.com.tw](http://www.100y.com.tw)

Figure 7-1. Timing Waveform

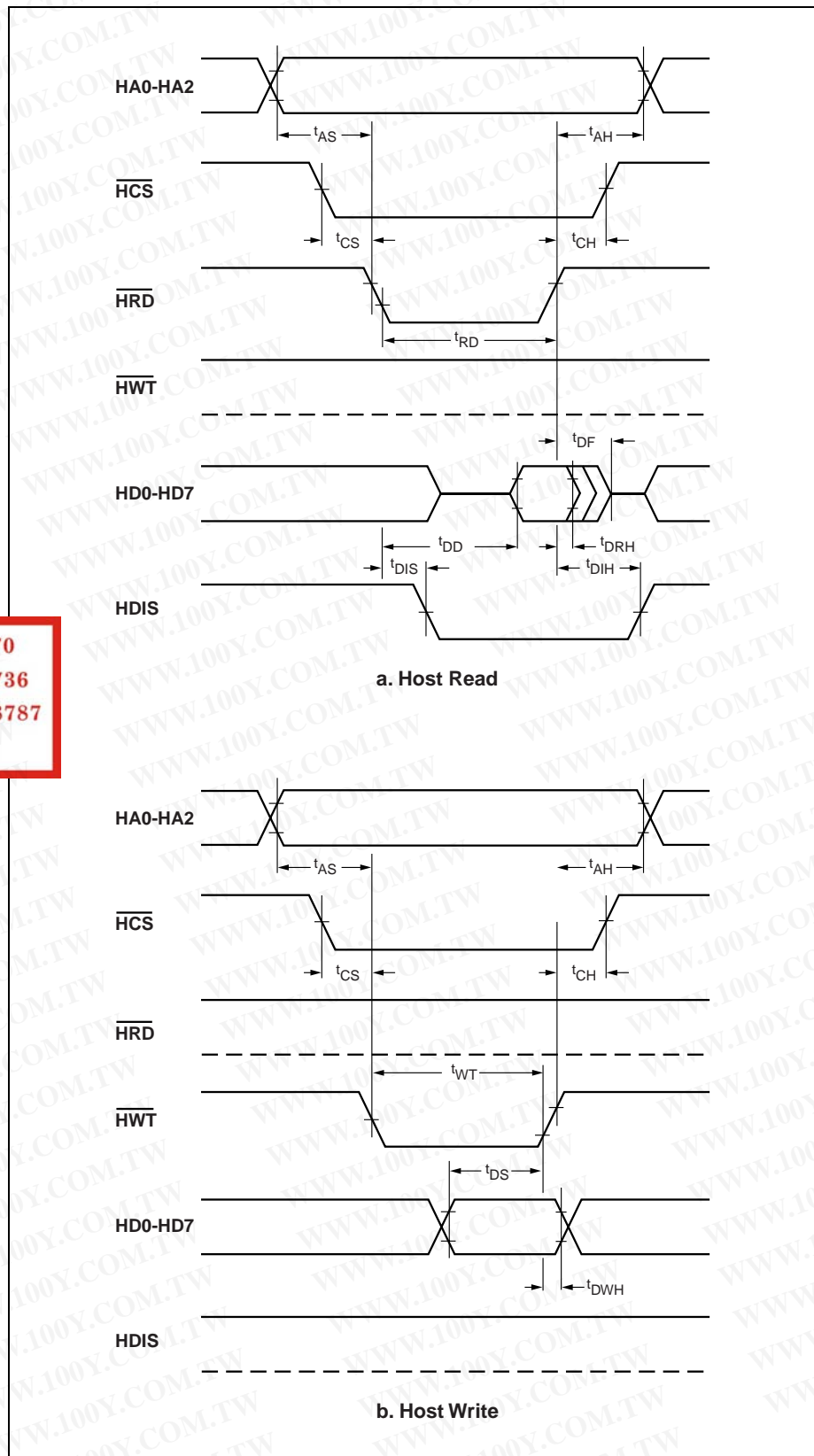

勝特力材料 886-3-5753170
 勝特力电子(上海) 86-21-54151736
 勝特力电子(深圳) 86-755-83298787
[Http://www.100y.com.tw](http://www.100y.com.tw)

Table 7-3. Current and Power Requirements

Mode	Current (ID)		Power (PD)	
	Typical Current @ 25°C	Maximum Current @ 0°C	Typical Power @ 25°C	Maximum Power @ 0°C
Operating	20 mA	22 mA	100 mW	110 mW
Sleep - Idle	5 mA	6 mA	25 mW	30 mW
Sleep - Stop	1 mA	1 mA	5 mW	5 mW

NOTE(S):

- Test conditions: VDD = 5.0 V_{DC} for typical values; VDD = 5.25 V_{DC} for maximum values.
- Test conditions: VDD = 3.3 V_{DC} for typical values; VDD = 3.6 V_{DC} for maximum values.

Table 7-4. Absolute Maximum Ratings

Parameter	Symbol	Limits	Units
Supply Voltage	V _{DD}	- 0.5 to + 7.0	V
Input Voltage	V _{IN}	- 0.5 to VCC + 0.5	V
Analog Inputs	V _{IN}	- 0.3 to + 5 VAA + 0.3	V
Voltage Applied to Outputs in High Z State	V _{HZ}	- 0.5 to + 5 VDD + 0.5	V
DC Input Clamp Current	I _{IK}	20	mA
DC Output Clamp Current	I _{OK}	20	mA
Static Discharge Voltage (@ 25°C)	V _{ESD}	3000	V
Latch-Up Current (@ 25°C)	I _{TRIG}	200	mA
Operating Temperature Range	T _A	- 0 to + 70	°C
Storage Temperature Range	T _{STG}	- 40 to + 80	°C

NOTE(S): Stresses above those listed may cause permanent damage to the device. This is a stress rating only, and functional operation at these or any other conditions above those listed in the operational section of this specification is not implied. Exposure to absolute maximum rating conditions for extended periods may affect device reliability.

勝特力材料 886-3-5753170
 勝特力电子(上海) 86-21-54151736
 勝特力电子(深圳) 86-755-83298787
[Http://www.100y.com.tw](http://www.100y.com.tw)

Table 7-5 lists digital interface characteristics, and Table 7-6 lists analog interface characteristics.

Table 7-5. Digital Interface Characteristics

Parameter	Symbol	Min.	Typ.	Max	Units	Test Conditions ⁽¹⁾
Input High Voltage Type IA Type DIO Type IH	V_{IH}	2.0 2.4 -30	— — —	V_{CC} V_{CC} 30	V_{DC}	—
Input Low Voltage Type IA, IC, and DO	V_{IL}	-0.3	—	0.8	V_{DC}	—
Input Low Voltage Type IF	V_{IL}	38	—	—	V_{RMS}	(2)
Input Leakage Current IA and IC	I_{IN}	—	—	10	μA_{dc}	$V_{IN} = 0$ to V_{CC}
Output High Voltage Type OA Type OD Type OG Type OH	V_{OH}	2.4 — — 5	— — — 8	— V_{CC} V_{CC} —	V_{DC}	$I_{LOAD} = -100 \mu\text{A}$ $I_{LOAD} = 0 \text{ mA}$
Output Low Voltage Type OA Type OB Type OD Type OG Type OH	V_{OL}	— — — 0.5 -8	— — 0.75 — -5	0.4 0.4 — — —	V_{DC}	$I_{LOAD} = 1.6 \text{ mA}$ $I_{LOAD} = 0.8 \text{ mA}$ $I_{LOAD} = 15 \text{ mA}$ $I_{LOAD} = 8 \text{ mA}$
Three-State (off) Current	I_{TS}	—	—	25	μA_{dc}	$V_{IN} = 0.8 \text{ V}$ to 4.5 V
<p>NOTE(S):</p> <p>(1) RC224ATL Test Conditions: $V_{CC} = 5 \text{ V } 5\%$, $T_A = 0^\circ\text{C}$ to 70°C (unless otherwise stated). RC224ATLV Test Conditions: $V_{CC} = 3.3 \text{ V } 5\%$, $T_A = 0^\circ\text{C}$ to 70°C (unless otherwise stated). Output loads: 50 pF + one TTL.</p> <p>(2) AC V_{RMS} voltage between Tip and Ring, using the on-board modular DAA.</p>						

勝特力材料 886-3-5753170
 勝特力电子(上海) 86-21-54151736
 勝特力电子(深圳) 86-755-83298787
[Http://www.100y.com.tw](http://www.100y.com.tw)

Table 7-6. Analog Interface Characteristics

Name	Type	Characteristic	Value
RXA	I (DA)	Input impedance	>50 k Ω
—	—	Voltage range	2.5 \pm 1.6 V
TXA1, TXA2	O (DD)	Minimum load	300 Ω
—	—	Maximum capacitive load	0.01 μ F
—	—	Output impedance	10 Ω
—	—	Output voltage	2.5 \pm 1.6 V
—	—	DC offset	<200 mV ⁽¹⁾
SPKR	O (DF)	Minimum load	300 Ω
—	—	Maximum capacitive load	0.01 μ F
—	—	Output impedance	10 Ω
—	—	Output voltage	2.5 \pm 1.6 V
—	—	DC offset	<20 mV ⁽¹⁾
NOTE(S): (1) With Reference to VC (2.5 V nominal).			

Figure 7-2 shows the mechanical drawing of the 68-pin PLCC. Table 7-7 lists its dimensions.

Figure 7-3 shows the mechanical drawing of the 100-pin PQFP. Table 7-8 lists its dimensions.

勝特力材料 886-3-5753170
 勝特力电子(上海) 86-21-54151736
 勝特力电子(深圳) 86-755-83298787
[Http://www.100y.com.tw](http://www.100y.com.tw)

Figure 7-2. 68-Pin PLCC

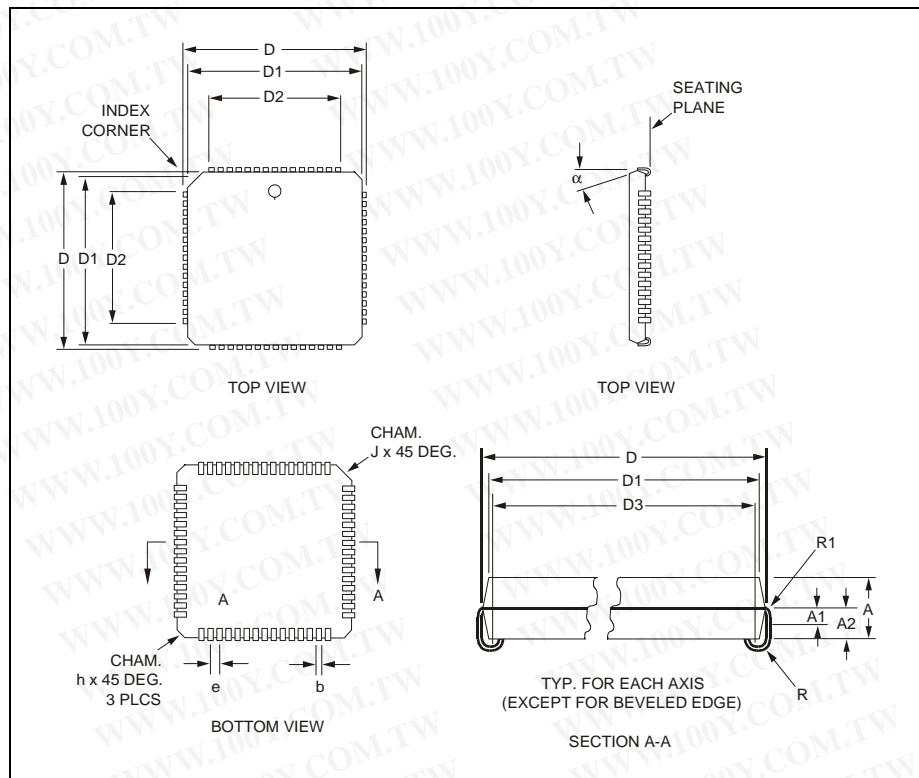

勝特力材料 886-3-5753170
 勝特力电子(上海) 86-21-54151736
 勝特力电子(深圳) 86-755-83298787
[Http://www.100y.com.tw](http://www.100y.com.tw)

Table 7-7. 68-Pin PLCC Dimensions

Dim	Millimeters		Inches	
	Min	Max	Min	Max
A	4.14	4.39	0.163	0.173
A1	1.37	1.47	0.054	0.058
A2	2.31	2.46	0.091	0.097
b	0.457 TYP		0.018 TYP	
D	25.02	25.27	0.985	0.995
D1	24.00	24.26	0.945	0.955
D2	20.19	20.45	0.795	0.805
D3	23.24	23.5	0.915	0.925
e	1.27 BSC		0.050 BSC	
h	0.254 TYP		0.010 TYP	
J	1.15 TYP		0.045 TYP	
α	45° TYP		45° TYP	
R	0.89 TYP		0.035 TYP	
R1	0.254 TYP		0.010 TYP	
NOTE(S): Reference: PD68J/GP00-D164				

勝特力材料 886-3-5753170
 勝特力电子(上海) 86-21-54151736
 勝特力电子(深圳) 86-755-83298787
[Http://www.100y.com.tw](http://www.100y.com.tw)

Figure 7-3. 100-Pin PQFP

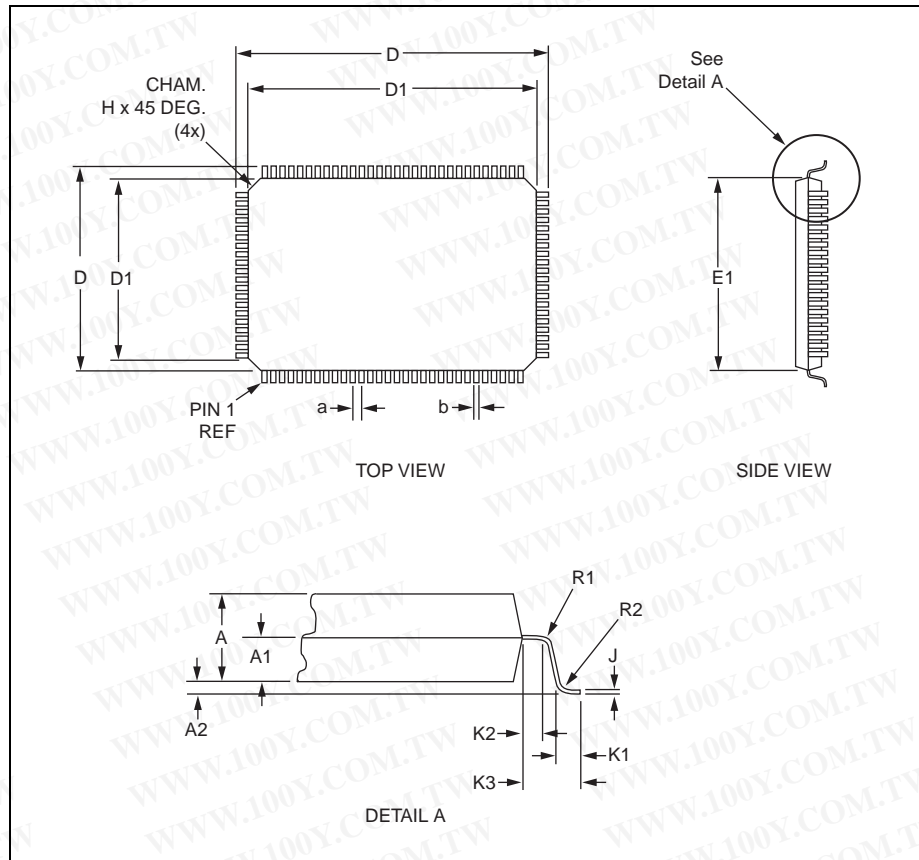

勝特力材料 886-3-5753170
 勝特力电子(上海) 86-21-54151736
 勝特力电子(深圳) 86-755-83298787
[Http://www.100y.com.tw](http://www.100y.com.tw)

Table 7-8. 100-Pin PQFP Dimensions

Dim	Millimeters		Inches	
	Min	Max	Min	Max
A	1.95	2.05	0.077	0.081
A1	0.95	1.05	0.037	0.041
A2	0.15	0.25	0.006	0.010
D	22.96	23.44	0.904	0.923
D1	19.89	20.09	0.783	0.791
E	16.94	17.45	0.667	0.687
E1	13.89	14.10	0.547	0.555
K1	0.70	0.90	0.028	0.035
K2	0.40	—	0.016	—
K3	1.60 REF		0.083 REF	
R1	0.13	—	0.005	—
R2	0.15	0.25	0.008	0.010
a	0.60	0.70	0.024	0.028
b	0.26	0.36	0.010	0.014
H	—	0.25	—	0.010
J	0.13	0.17	0.005	0.007

NOTE(S): Reference: GP00-D234

勝特力材料 886-3-5753170
 勝特力电子(上海) 86-21-54151736
 勝特力电子(深圳) 86-755-83298787
[Http://www.100y.com.tw](http://www.100y.com.tw)

Appendix A: RC224ATF Modem Designs

This appendix describes two modem design examples. The schematics and parts lists are provided for designs incorporating the RC224ATF packaged in a 68-pin PLCC and implemented with either a parallel or serial interface.

A.1 68-Pin PLCC Design for Serial Interface

Figure A-1 and Figure A-2 provide the schematic of a RC224ATF 68-pin PLCC serial interface board design. Table A-1 lists the bill of materials for this design.

勝特力材料 886-3-5753170
勝特力电子(上海) 86-21-54151736
勝特力电子(深圳) 86-755-83298787
[Http://www.100y.com.tw](http://www.100y.com.tw)

Figure A-1. Serial Interface Design

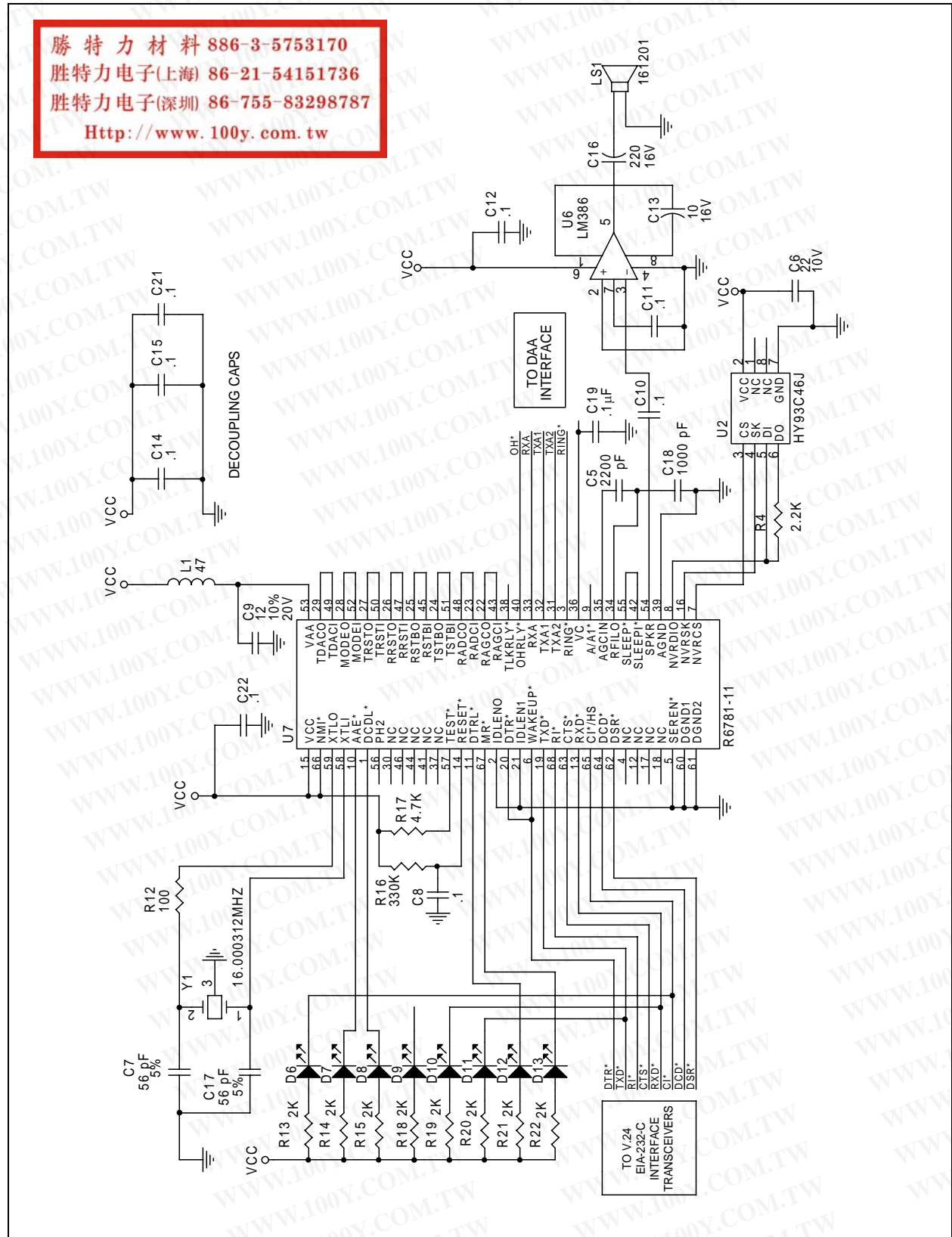

勝特力材料 886-3-5753170
 勝特力电子(上海) 86-21-54151736
 勝特力电子(深圳) 86-755-83298787
 Http://www.100y.com.tw

Figure A-2. Serial Interface Design DAA

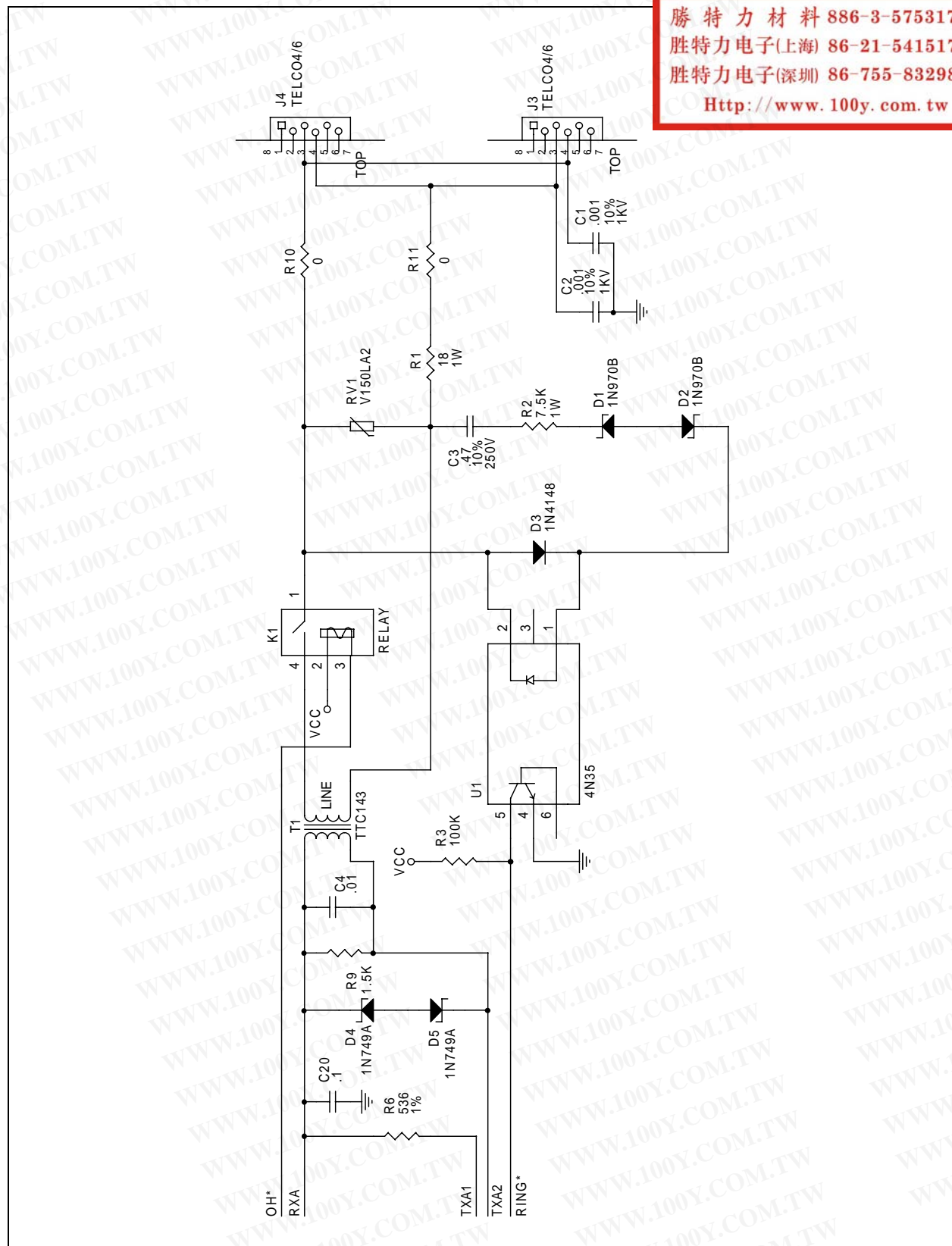

勝特力材料 886-3-5753170
 勝特力电子(上海) 86-21-54151736
 勝特力电子(深圳) 86-755-83298787
[Http://www.100y.com.tw](http://www.100y.com.tw)

Table A-1. Serial Bill of Materials (1 of 2)

Item	Quantity	Reference	Part
1	2	C2,C1	0.001
2	1	C3	0.47
3	1	C4	.01
4	1	C5	2200 pF
5	1	C6	22
6	2	C7,C17	56 pF
7	9	C8,C10,C11,C12,C14,C15,C19, C20,C21	0.1
8	1	C9	12
9	1	C13	10
10	1	C16	220
11	1	C18	1000 pF
12	2	D1,D2	1N970B
13	1	D3	1N4148
14	2	D5,D4	1N749A
15	8	D6,D7,D8,D9,D10,D11,D12,D13	
16	2	J4,J3	TELC04/6
17	1	K1	RELAY
18	1	LS1	161201
19	1	L1	47
20	1	RV1	V150LA2
21	1	R1	18
22	1	R2	7.5 k
23	1	R3	100 k
24	1	R4	2.2 k
25	1	R6	536
26	1	R9	1.5 k
27	2	R11,R10	0
28	1	R12	100
29	8	R13,R14,R15,R18,R19,R20,R21, R22	2 k

勝特力材料 886-3-5753170
 勝特力电子(上海) 86-21-54151736
 勝特力电子(深圳) 86-755-83298787
[Http://www.100y.com.tw](http://www.100y.com.tw)

Table A-1. Serial Bill of Materials (2 of 2)

Item	Quantity	Reference	Part
30	1	R16	330 k
31	1	R17	4.7 k
32	1	T1	TTC143
33	1	U1	4N35
34	1	U2	HY93C46J
35	1	U6	LM386
36	1	U7	R6781-11
37	1	Y1	16.000312 MHz

勝特力材料 886-3-5753170
 勝特力电子(上海) 86-21-54151736
 勝特力电子(深圳) 86-755-83298787
[Http://www.100y.com.tw](http://www.100y.com.tw)

A.2 68-Pin PLCC Design for Parallel Interface

Figure A-3 and Figure A-4 provide the schematic of a RC224ATF 68-pin PLCC parallel interface board design. Table A-2 lists the bill of materials for this design.

勝特力材料 886-3-5753170
勝特力电子(上海) 86-21-54151736
勝特力电子(深圳) 86-755-83298787
[Http://www.100y.com.tw](http://www.100y.com.tw)

Figure A-3. Parallel Interface Design

勝特力材料 886-3-5753170
 勝特力电子(上海) 86-21-54151736
 勝特力电子(深圳) 86-755-83298787
[Http://www.100y.com.tw](http://www.100y.com.tw)

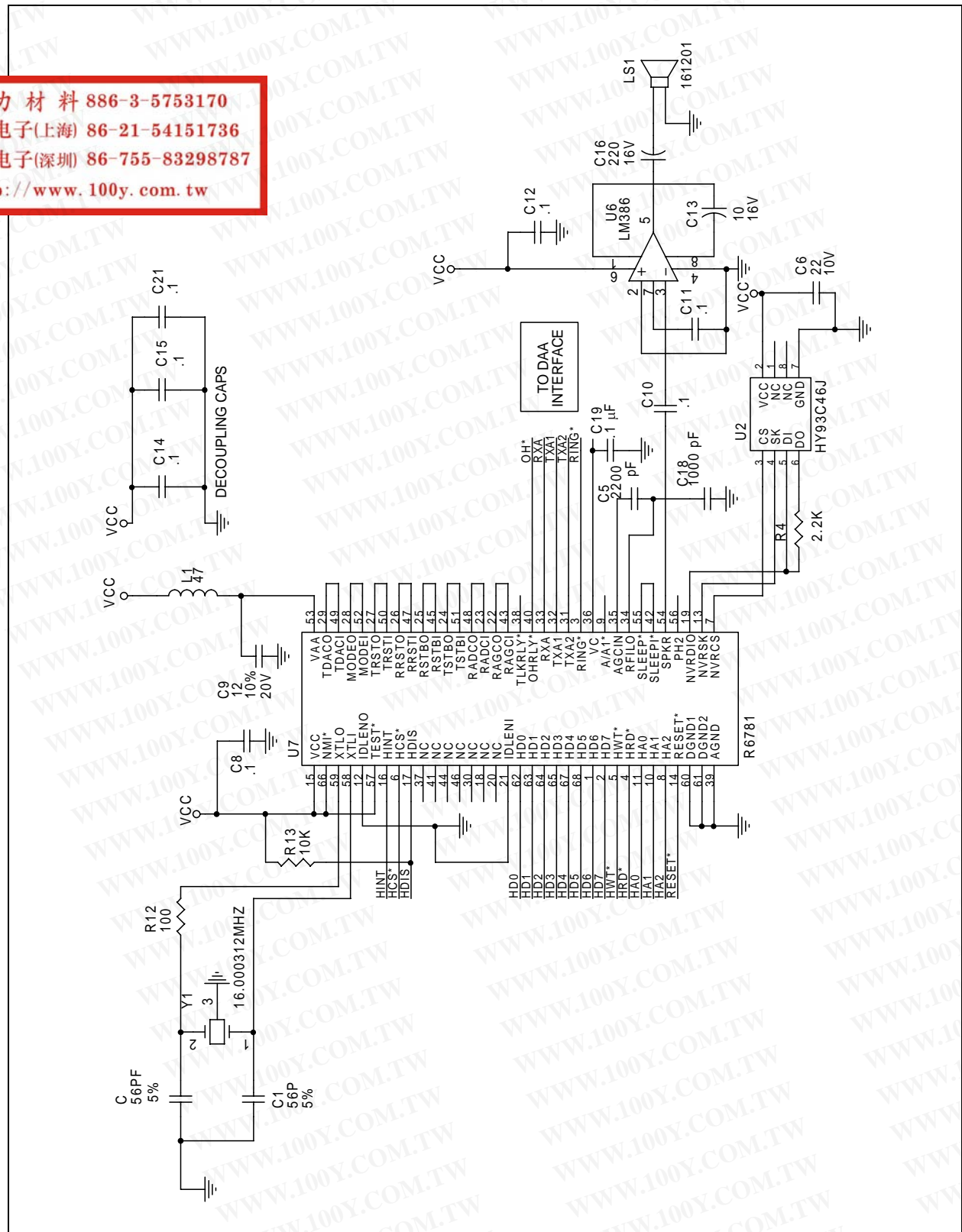

Figure A-4. Parallel Interface Design DAA

勝特力材料 886-3-5753170
 勝特力电子(上海) 86-21-54151736
 勝特力电子(深圳) 86-755-83298787
 Http://www.100y.com.tw

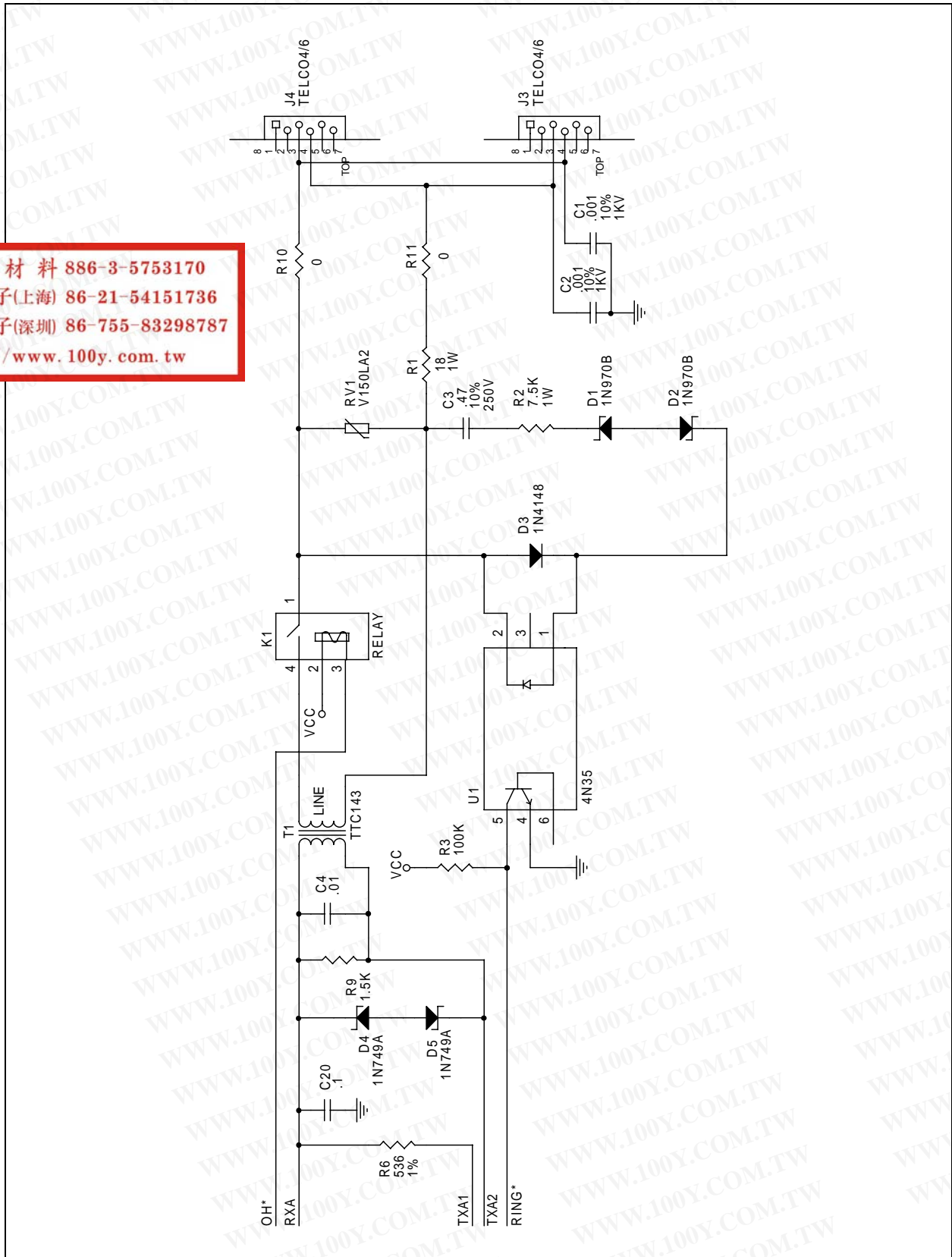

Table A-2. Parallel Billing Materials (1 of 2)

Item	Quantity	Reference	Part
1	2	C2,C1	0.001
2	1	C3	0.47
3	1	C4	0.01
4	1	C5	2200 pF
5	1	C6	22
6	2	C7,C17	56 pF
7	8	C8,C10,C11,C12,C14,C15,C20, C21	0.1
8	1	C9	12
9	1	C13	10
10	1	C16	220
11	1	C18	1000 pF
12	1	C19	0.1 μ F
13	2	D1,D2	1N970B
14	1	D3	1N4148
15	2	D5,D4	1N749A
16	2	J4,J3	TELC04/6
17	1	K1	RELAY
18	1	LS1	161201
19	1	L1	47
20	1	RV1	V150LA2
21	1	R1	18
22	1	R2	7.5 k
23	1	R3	100 k
24	1	R4	2.2 k
25	1	R6	536
26	1	R9	1.5 k
27	2	R11,R10	0
28	1	R12	100
29	1	R13	10 k

勝特力材料 886-3-5753170
 勝特力电子(上海) 86-21-54151736
 勝特力电子(深圳) 86-755-83298787
[Http://www.100y.com.tw](http://www.100y.com.tw)

Table A-2. Parallel Billing Materials (2 of 2)

Item	Quantity	Reference	Part
30	1	T1	TTC143
31	1	U1	4N35
32	1	U2	HY93C46J
33	1	U6	LM386
34	1	U7	R6781
35	1	Y1	16.000312 MHz

勝特力材料 86-3-5753170
 勝特力电子(上海) 86-21-54151736
 勝特力电子(深圳) 86-755-83298787
[Http://www.100y.com.tw](http://www.100y.com.tw)

Appendix B: Acronyms/Abbreviations

勝特力材料 886-3-5753170
勝特力电子(上海) 86-21-54151736
勝特力电子(深圳) 86-755-83298787
[Http://www.100y.com.tw](http://www.100y.com.tw)

A-B

AGC Automatic Gain Control
AT Attention Code

C

CCITT International Telegraph and Telephone Consultative Committee
CRC Cyclic Redundancy Check
CTS Clear to Send

D

DAC Digital-to-Analog Converter
DCE Data Communication Equipment
DTE Host Data Terminal Equipment
DTMF Dual-Tone Multifrequency
DTR Data Terminal Ready (name of bit and function)

E-F

EOP End of Process
FCS Frame Check Sequence

I

IER Interrupt Enable Register
IIR Interrupt Identifier Register

L

LCR Line Control Register
LED Light Emitting Diode
LSR Line Status Register

M

MCR	Modem Control Register
MCU	Microcontroller Unit
MSR	Modem Status Register

O-P

OEM	Original Equipment Manufacturer
op amp	operational amplifier
PBX	Private Branch Exchange

R-S

RBR	Receiver Buffer Register
RTS	Request to Send (name of bit and function)
SCR	Scratchpad Register

T-U

THR	Transmit Holding Register
TTL	Transistor-to-Transistor Logic
UART	Universal Asynchronous Receiver/Transmitter

X

X-on/X-off	Transistor On/Off
------------	-------------------

勝特力材料 886-3-5753170
勝特力电子(上海) 86-21-54151736
勝特力电子(深圳) 86-755-83298787
[Http://www.100y.com.tw](http://www.100y.com.tw)