

**10A, 30V, 0.200 Ohm, Logic Level,  
P-Channel Power MOSFET**

These products are P-Channel power MOSFETs manufactured using the MegaFET process. This process, which uses feature sizes approaching those of LSI circuits, gives optimum utilization of silicon, resulting in outstanding performance. They were designed for use in applications such as switching regulators, switching converters, motor drivers, and relay drivers. These transistors can be operated directly from integrated circuits.

Formerly developmental type TA49205.

**Ordering Information**

PART NUMBER	PACKAGE	BRAND
RFD10P03L	TO-251AA	10P03L
RFD10P03LSM	TO-252AA	10P03L
RFP10P03L	TO-220AB	F10P03L

NOTE: When ordering, use the entire part number. Add the suffix, 9A, to obtain the TO-252AA variant in tape and reel, i.e. RFD10P03LSM9A..

**Features**

- 10A, 30V
- $r_{DS(ON)} = 0.200\Omega$
- Temperature Compensating PSPICE® Model
- PSPICE Thermal Model
- Peak Current vs Pulse Width Curve
- UIS Rating Curve
- 175°C Operating Temperature

**Symbol**

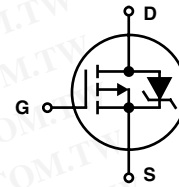

**Packaging**

JEDEC TO-251AA

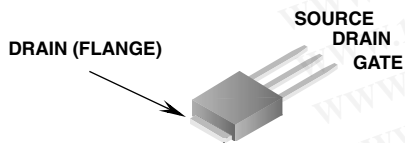

JEDEC TO-252AA

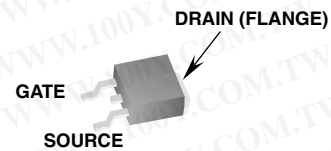

JEDEC TO-220AB

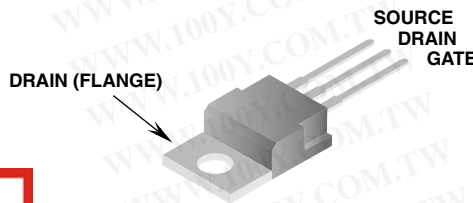

勝特力材料 886-3-5753170  
 勝特力电子(上海) 86-21-54151736  
 勝特力电子(深圳) 86-755-83298787  
[Http://www.100y.com.tw](http://www.100y.com.tw)

# RFD10P03L, RFD10P03LSM, RFP10P03L

勝特力材料 886-3-5753170  
 勝特力电子(上海) 86-21-54151736  
 勝特力电子(深圳) 86-755-83298787  
[Http://www.100y.com.tw](http://www.100y.com.tw)

## Absolute Maximum Ratings $T_C = 25^\circ\text{C}$ Unless Otherwise Specified

Drain to Source Voltage	$V_{DSS}$
Drain to Gate Voltage ( $R_{GS} = 20K\Omega$ )	$V_{DGR}$
Gate to Source Voltage	$V_{GS}$
Drain Current	
RMS Continuous	$I_D$
Pulsed Drain Current	$I_{DM}$
Single Pulse Avalanche Rating	$E_{AS}$
Power Dissipation	$P_D$
Derate Above $25^\circ\text{C}$	
Operating and Storage Temperature	$T_J, T_{STG}$
Maximum Lead Temperature for Soldering (0.063in (1.6mm) from case for 10s)	$T_L$

RFD10P03L, RFD10P03LSM, RFP10P03L	UNITS
-30	V
-30	V
$\pm 10$	V
10	A
See Figure 5	
Refer to UIS Curve	
65	W
0.43	$W/^\circ\text{C}$
-55 to 175	$^\circ\text{C}$
300	$^\circ\text{C}$

CAUTION: Stresses above those listed in "Absolute Maximum Ratings" may cause permanent damage to the device. This is a stress only rating and operation of the device at these or any other conditions above those indicated in the operational sections of this specification is not implied.

### NOTE:

- $T_J = 25^\circ\text{C}$  to  $150^\circ\text{C}$

## Electrical Specifications $T_C = 25^\circ\text{C}$ , Unless Otherwise Specified

PARAMETER	SYMBOL	TEST CONDITIONS	MIN	TYP	MAX	UNITS
Drain to Source Breakdown Voltage	$BV_{DSS}$	$I_D = 250\mu\text{A}, V_{GS} = 0\text{V}$ (Figure 11)	-30	-	-	V
Gate Threshold Voltage	$V_{GS(TH)}$	$V_{GS} = V_{DS}, I_D = 250\mu\text{A}$ (Figure 12)	-1	-	-2	V
Zero Gate Voltage Drain Current	$I_{DSS}$	$V_{DS} = -30\text{V}, T_C = 25^\circ\text{C}$	-	-	-1	$\mu\text{A}$
		$V_{GS} = 0\text{V}, T_C = 150^\circ\text{C}$	-	-	-50	$\mu\text{A}$
Gate to Source Leakage Current	$I_{GSS}$	$V_{GS} = \pm 10\text{V}$	-	-	$\pm 100$	nA
Drain to Source On Resistance (Note 1)	$r_{DS(ON)}$	$I_D = 10\text{A}, V_{GS} = -5\text{V}$ (Figures 9, 10)	-	-	0.200	$\Omega$
		$I_D = 10\text{A}, V_{GS} = -4.5\text{V}$ (Figures 9, 10)	-	-	0.220	$\Omega$
Turn-On Time	$t_{ON}$	$V_{DD} = 15\text{V}, I_D \cong 10\text{A}, R_L = 1.5\Omega,$ $R_{GS} = 5\Omega, V_{GS} = -5\text{V}$ (Figure 13)	-	-	100	ns
Turn-On Delay Time	$t_{d(ON)}$		-	15	-	ns
Rise Time	$t_r$		-	50	-	ns
Turn-Off Delay Time	$t_{d(OFF)}$		-	35	-	ns
Fall Time	$t_f$		-	20	-	ns
Turn-Off Time	$t_{OFF}$		-	-	80	ns
Total Gate Charge	$Q_g(TOT)$	$V_{GS} = 0$ to $-10\text{V}$	-	25	30	nC
Gate Charge at -5V	$Q_g(-5)$	$V_{GS} = 0$ to $-5\text{V}$				
Threshold Gate Charge	$Q_g(TH)$	$V_{GS} = 0$ to $-1\text{V}$				
Input Capacitance	$C_{ISS}$	$V_{DS} = -25\text{V}, V_{GS} = 0\text{V}, f = 1\text{MHz}$ (Figure 15)	-	1035	-	pF
Output Capacitance	$C_{OSS}$		-	340	-	pF
Reverse Transfer Capacitance	$C_{RSS}$		-	35	-	pF
Thermal Resistance, Junction to Case	$R_{\theta JC}$			-	-	2.30
Thermal Resistance, Junction to Ambient	$R_{\theta JA}$	RFD10P03L, RFD10P03LSM	-	-	100	$^\circ\text{C/W}$
		RFP10P03L	-	-	80	$^\circ\text{C/W}$

## Source to Drain Diode Specifications

PARAMETER	SYMBOL	TEST CONDITIONS	MIN	TYP	MAX	UNITS
Source to Drain Forward Voltage	$V_{SD}$	$I_{SD} = -10\text{A}$	-	-	-1.5	V
Reverse Recovery Time	$t_{rr}$	$I_{SD} = -10\text{A}, dI_{SD}/dt = -100\text{A}/\mu\text{s}$	-	-	75	ns

### NOTE:

- Pulse Test: Pulse width  $\leq 300\mu\text{s}$ , Duty Cycle  $\leq 2\%$ .

Typical Performance Curves Unless Otherwise Specified

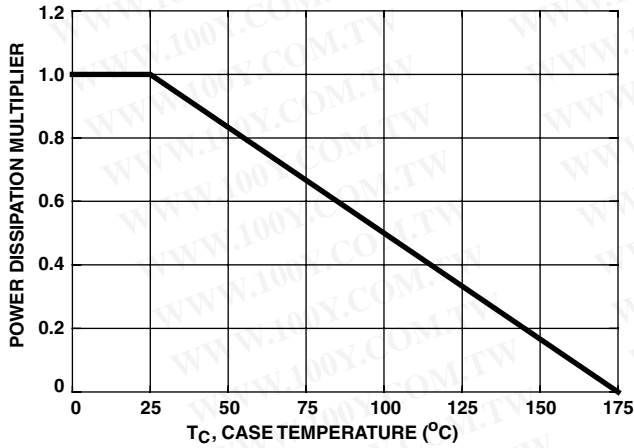

FIGURE 1. NORMALIZED POWER DISSIPATION vs CASE TEMPERATURE

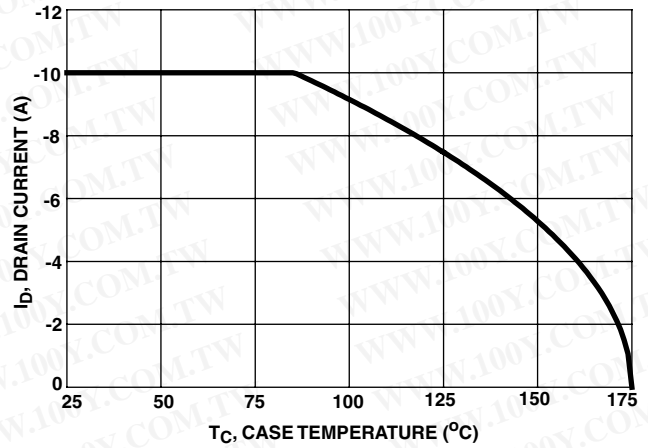

FIGURE 2. MAXIMUM CONTINUOUS DRAIN CURRENT vs CASE TEMPERATURE

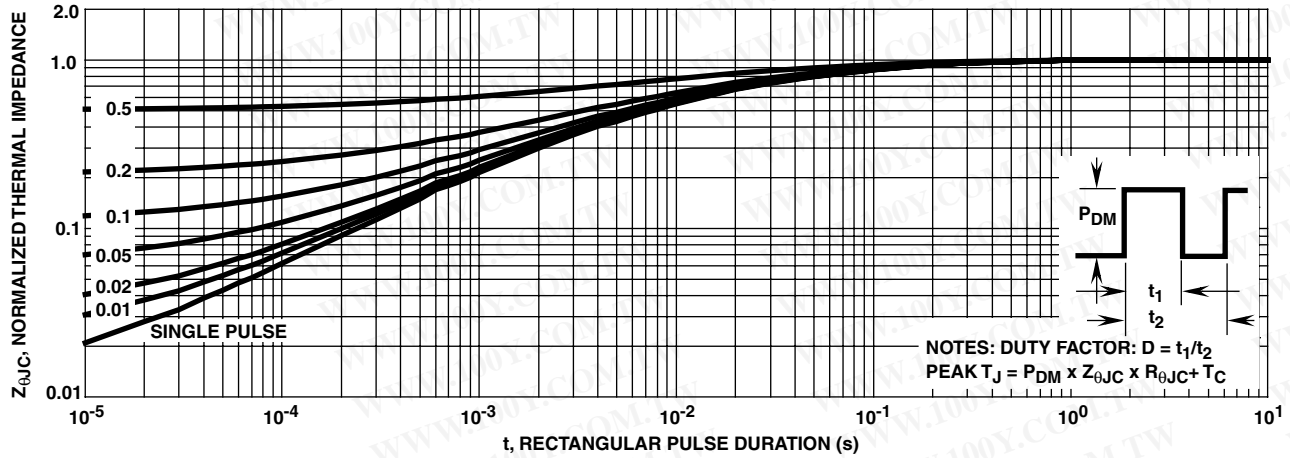

FIGURE 3. NORMALIZED MAXIMUM TRANSIENT THERMAL IMPEDANCE

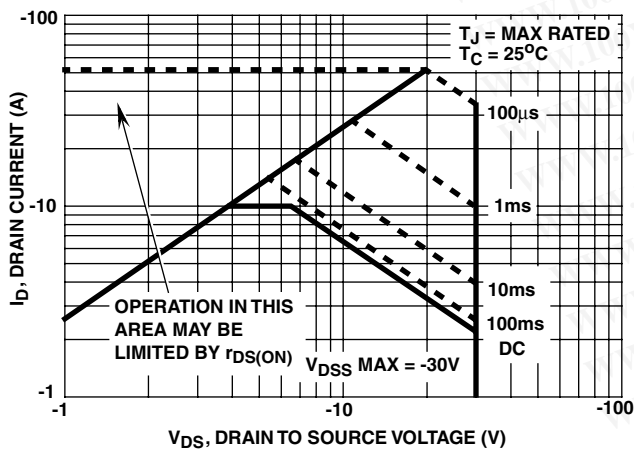

FIGURE 4. FORWARD BIAS SAFE OPERATING AREA

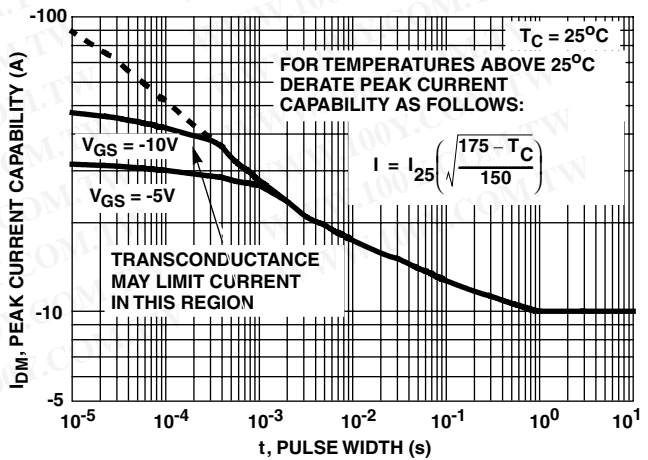
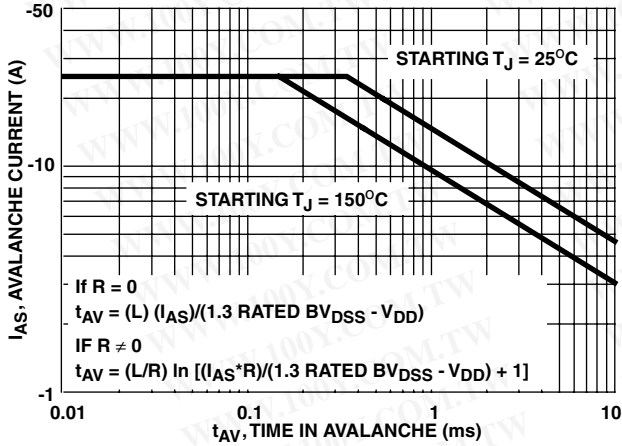

FIGURE 5. PEAK CURRENT CAPABILITY

Typical Performance Curves Unless Otherwise Specified (Continued)



NOTE: Refer to Fairchild Application Notes AN9321 and AN9322.

FIGURE 6. UNCLAMPED INDUCTIVE SWITCHING CAPABILITY

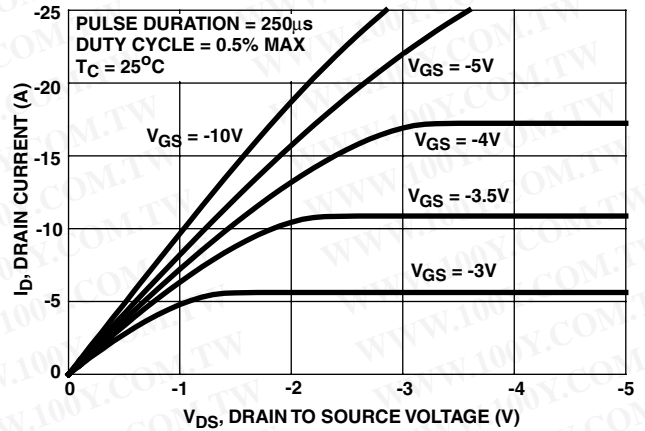

FIGURE 7. SATURATION CHARACTERISTICS

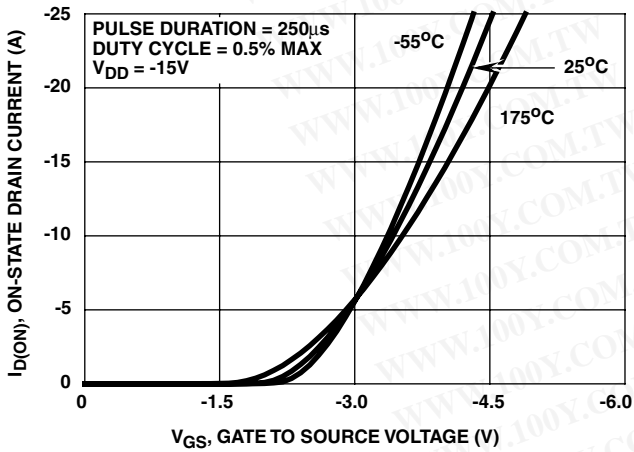

FIGURE 8. TRANSFER CHARACTERISTICS

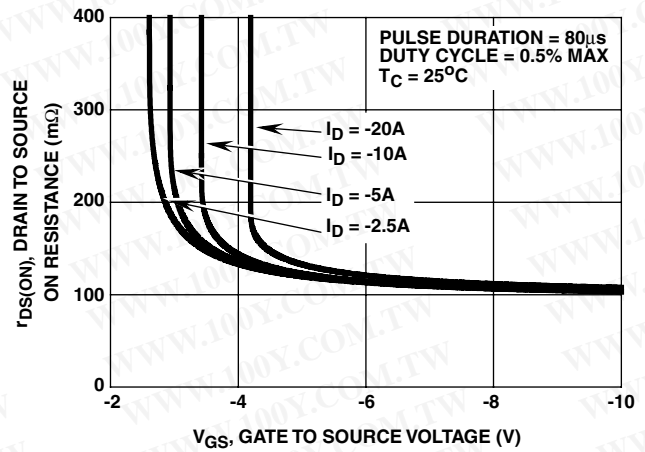

FIGURE 9. DRAIN TO SOURCE ON RESISTANCE vs GATE VOLTAGE AND DRAIN CURRENT

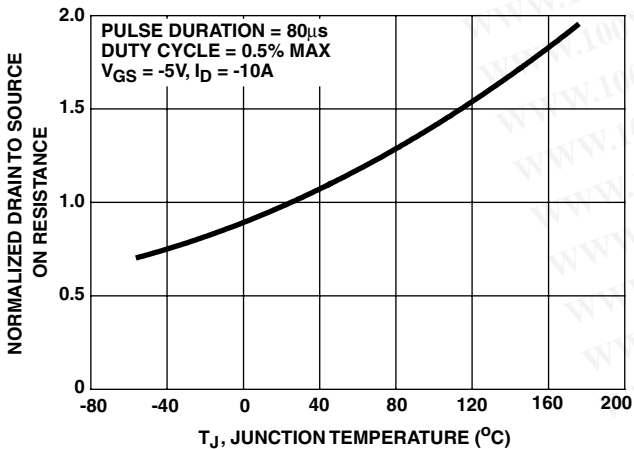

FIGURE 10. NORMALIZED DRAIN TO SOURCE ON RESISTANCE vs JUNCTION TEMPERATURE

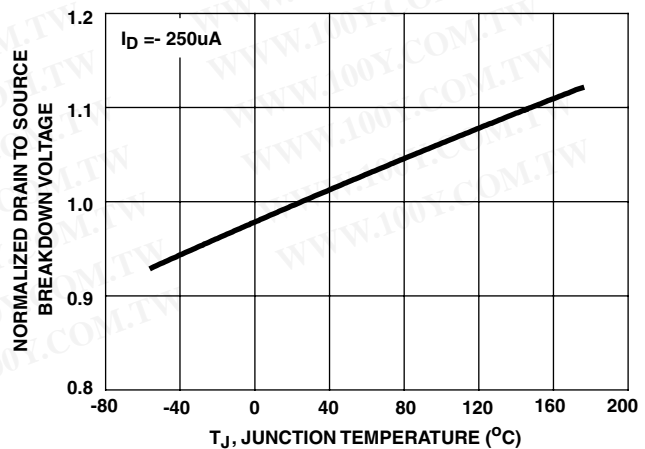

FIGURE 11. NORMALIZED DRAIN TO SOURCE BREAKDOWN VOLTAGE vs JUNCTION TEMPERATURE



Typical Performance Curves Unless Otherwise Specified (Continued)

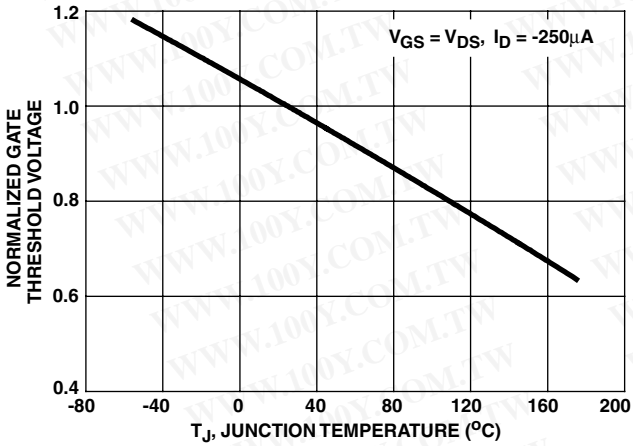

FIGURE 12. NORMALIZED GATE THRESHOLD VOLTAGE vs JUNCTION TEMPERATURE

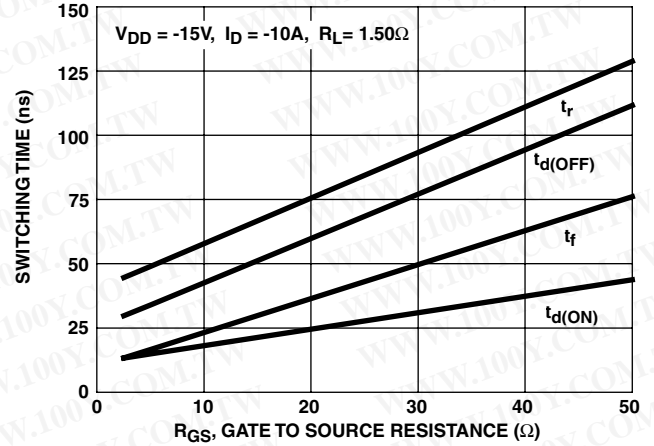
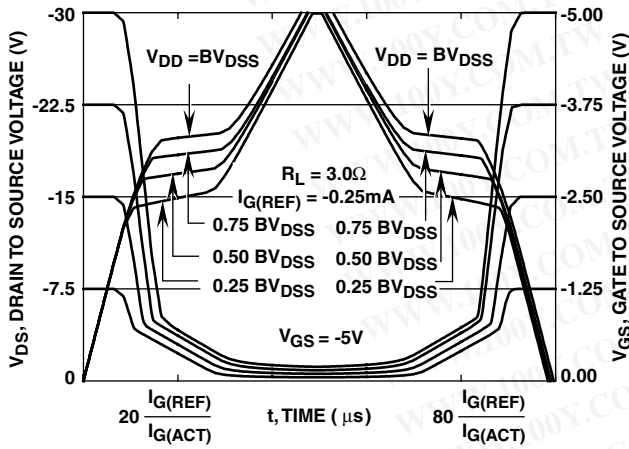

FIGURE 13. SWITCHING TIME vs GATE RESISTANCE



NOTE: Refer to Fairchild Application Notes AN7254 and AN7260.

FIGURE 14. NORMALIZED SWITCHING WAVEFORMS FOR CONSTANT GATE CURRENT

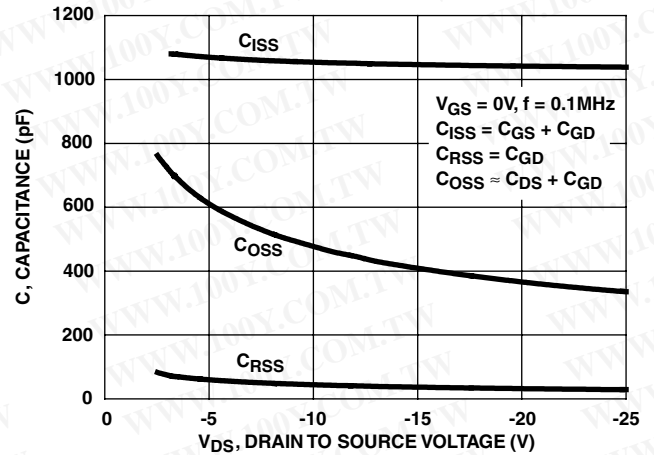

FIGURE 15. CAPACITANCE vs DRAIN TO SOURCE VOLTAGE

Test Circuits and Waveforms

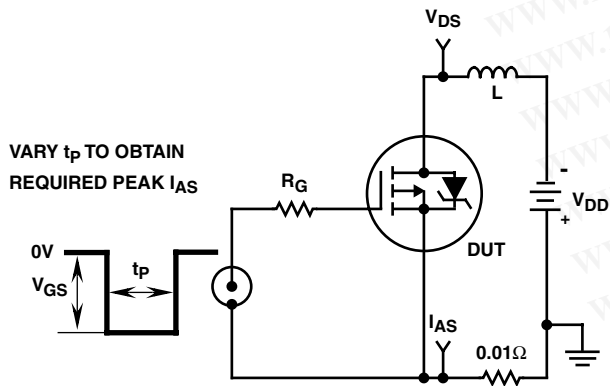

FIGURE 16. UNCLAMPED ENERGY TEST CIRCUIT

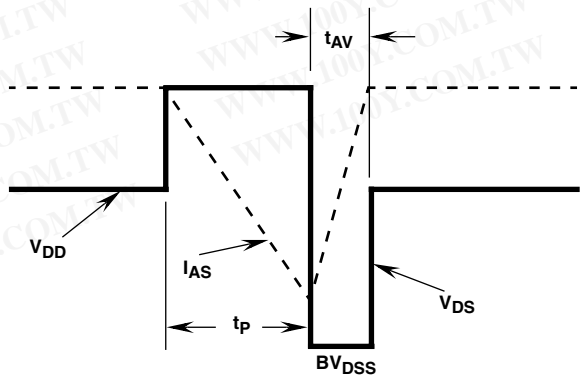

FIGURE 17. UNCLAMPED ENERGY WAVEFORMS

Test Circuits and Waveforms (Continued)

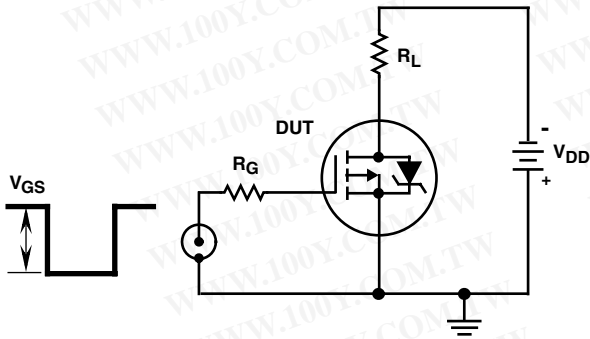

FIGURE 18. SWITCHING TIME TEST CIRCUIT

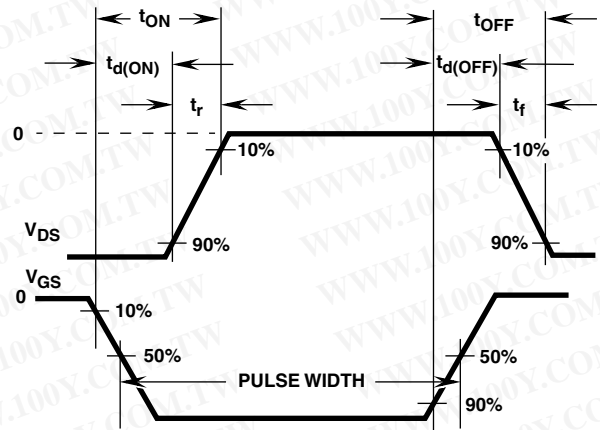

FIGURE 19. RESISTIVE SWITCHING WAVEFORMS

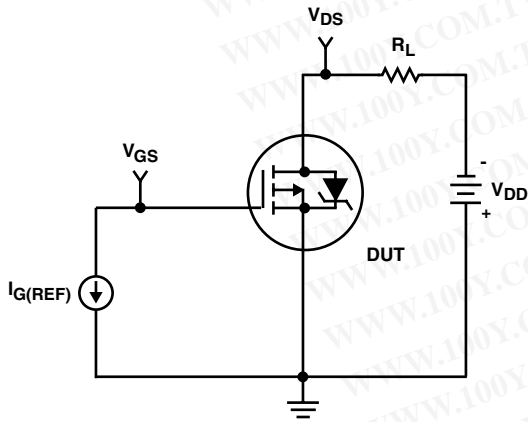

FIGURE 20. GATE CHARGE TEST CIRCUIT

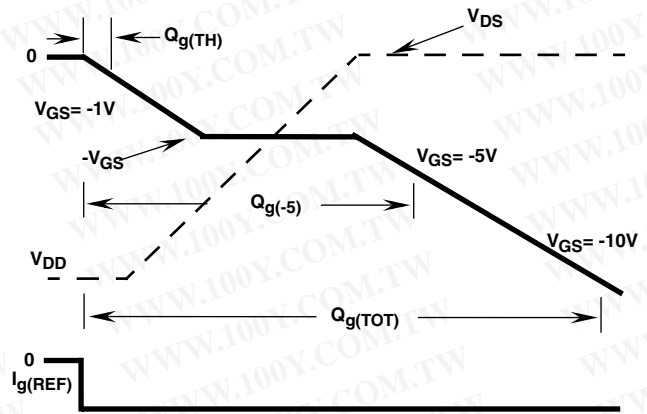

FIGURE 21. GATE CHARGE WAVEFORMS

**PSpice Electrical Model**

.SUBCKT RFD10P03L 2 1 3 REV 22 Aug 96

CA 12 8 1.29e-9  
 CB 15 14 9.90e-10  
 CIN 6 8 1.01e-9

DBODY 5 7 DBODYMOD  
 DBREAK 7 11 DBREAKMOD  
 DPLCAP 10 6 DPLCAPMOD

EBREAK 5 11 17 18 -36.49  
 EDS 14 8 5 8 1  
 EGS 13 8 6 8 1  
 ESG 5 10 8 6 1  
 EVTHRES 6 21 19 8 1  
 EVTEMP 6 20 18 22 1

IT 8 17 1

LDRAIN 2 5 1e-9  
 LGATE 1 9 3.40e-9  
 LSOURCE 3 7 3.22e-9

MMED 16 6 8 8 MmedMOD  
 MSTRO 16 6 8 8 MstroMOD  
 MWEAK 16 21 8 8 MweakMOD

RBREAK 17 18 RBREAKMOD 1  
 RDRAIN 50 16 RDRAINMOD 68.25e-3  
 RGATE 9 20 2.54  
 RSLC1 5 51 51 RSLC1MOD 1e-6  
 RSLC2 5 50 1e3  
 RSOURCE 8 7 RSourceMOD 25.00e-3  
 RVTHRES 22 8 RVTHRESMOD 1  
 RVTEMP 18 19 RVTEMPMOD 1

S1A 6 12 13 8 S1AMOD  
 S1B 13 12 13 8 S1BMOD  
 S2A 6 15 14 13 S2AMOD  
 S2B 13 15 14 13 S2BMOD

VBAT 22 19 DC 1

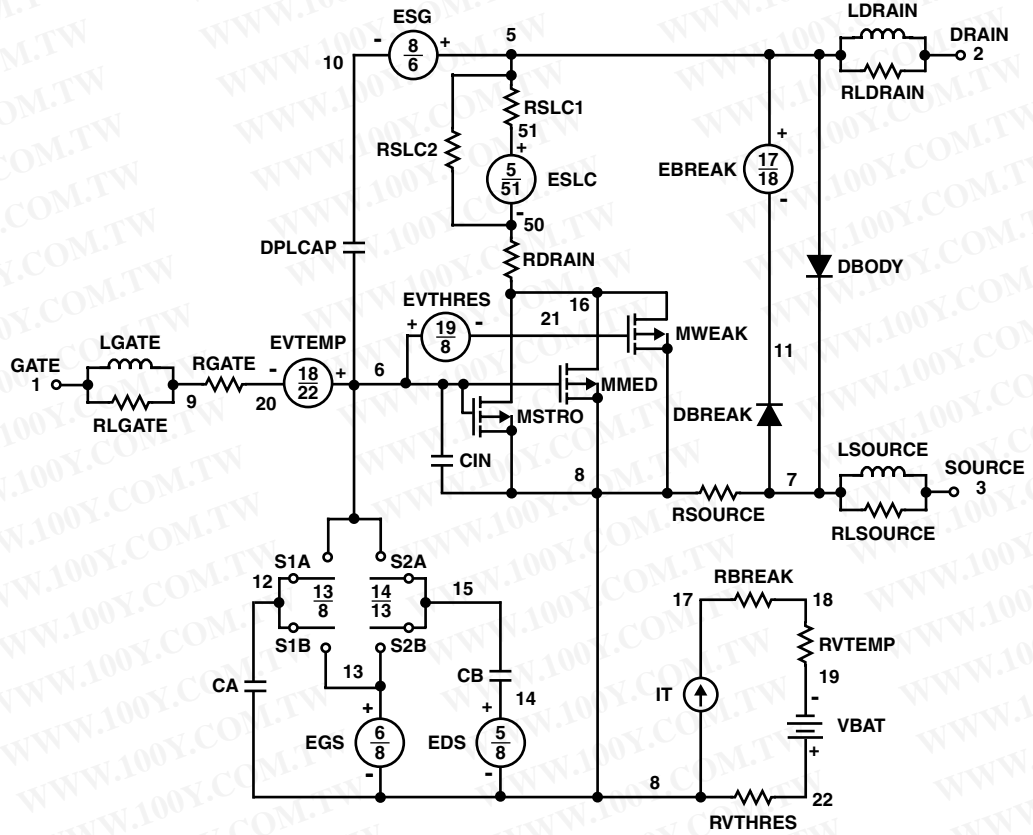

ESCL 51 50 VALUE={ (V(5,51)/ABS(V(5,51))) \* (PWR(V(5,51)/(1e-6\*33),5.0)) }

```
.MODEL DBODYMOD D (IS=9.15e-13 RS=3.25e-2 IKF=0.05 N=0.97 TRS1=4.11e-5 TRS2=2.03e-6 CJO=1.13e-9 M=0.40 TT=3.72e-8)
.MODEL DBREAKMOD D (RS=2.62e-1 TRS1=1.74e-3 TRS2=-3.81e-6)
.MODEL DPLCAPMOD D (CJO=1.46e-10 IS=1e-30 N=10 M=0.50)
.MODEL MSTRONGMOD PMOS (VTO=-1.95 KP=11.60 IS=1e-30 N=10 TOX=1 L=1u W=1u)
.MODEL MMEDMOD PMOS (VTO=-1.65 KP=1.00 IS=1e-30 N=10 TOX=1 L=1u W=1u RG=2.54)
.MODEL MWEAKMOD PMOS (VTO=-1.43 KP=0.09 IS=1e-30 N=10 TOX=1 L=1u W=1u RG=25.4 RS=0.1)
.MODEL RBREAKMOD RES (TC1=9.17e-4 TC2=-2.74e-7)
.MODEL RDRAINMOD RES (TC1=6.35e-3 TC2=1.98e-5)
.MODEL RSOURCEMOD RES (TC1=0 TC2=0)
.MODEL RSLC1MOD RES (TC1=2e-3 TC2=0)
.MODEL RVTHRESMOD RES (TC1=1.23e-3 TC2=1.97e-6)
.MODEL RVTEMPMOD RES (TC1=-1.18e-3 TC2=1.44e-6)
.MODEL S1AMOD VSWITCH (RON=1e-5 ROFF=0.1 VON=4.80 VOFF=1.80)
.MODEL S1BMOD VSWITCH (RON=1e-5 ROFF=0.1 VON=1.80 VOFF=4.80)
.MODEL S2AMOD VSWITCH (RON=1e-5 ROFF=0.1 VON=-0.40 VOFF=-3.40)
.MODEL S2BMOD VSWITCH (RON=1e-5 ROFF=0.1 VON=-3.40 VOFF=-0.40)
ENDS
```

For further discussion of the PSPICE model consult A New PSPICE Sub-circuit for the Power MOSFet Featuring Global Temperature Options; authored by William J. Hepp and C. Frank Wheatley.

**PSpice Thermal Model**

REV 29 Aug 96

RFP10P03L

CTHERM1 7 6 5.00e-7  
 CTHERM2 6 5 5.35e-4  
 CTHERM3 5 4 5.50e-4  
 CTHERM4 4 3 1.75e-3  
 CTHERM5 3 2 1.25e-2  
 CTHERM6 2 1 0.45

RTHERM1 7 6 1.00e-2  
 RTHERM2 6 5 2.05e-2  
 RTHERM3 5 4 5.39e-2  
 RTHERM4 4 3 5.45e-1  
 RTHERM5 3 2 1.01  
 RTHERM6 2 1 0.50

RFD10P03L, RFD10P03LSM

CTHERM1 7 6 5.00e-7  
 CTHERM2 6 5 5.35e-4  
 CTHERM3 5 4 5.50e-4  
 CTHERM4 4 3 1.75e-3  
 CTHERM5 3 2 1.25e-2  
 CTHERM6 2 1 0.11

RTHERM1 7 6 1.00e-2  
 RTHERM2 6 5 2.05e-2  
 RTHERM3 5 4 5.39e-2  
 RTHERM4 4 3 5.45e-1  
 RTHERM5 3 2 1.01  
 RTHERM6 2 1 0.50

勝特力材料 886-3-5753170  
 勝特力电子(上海) 86-21-54151736  
 勝特力电子(深圳) 86-755-83298787  
[Http://www.100y.com.tw](http://www.100y.com.tw)

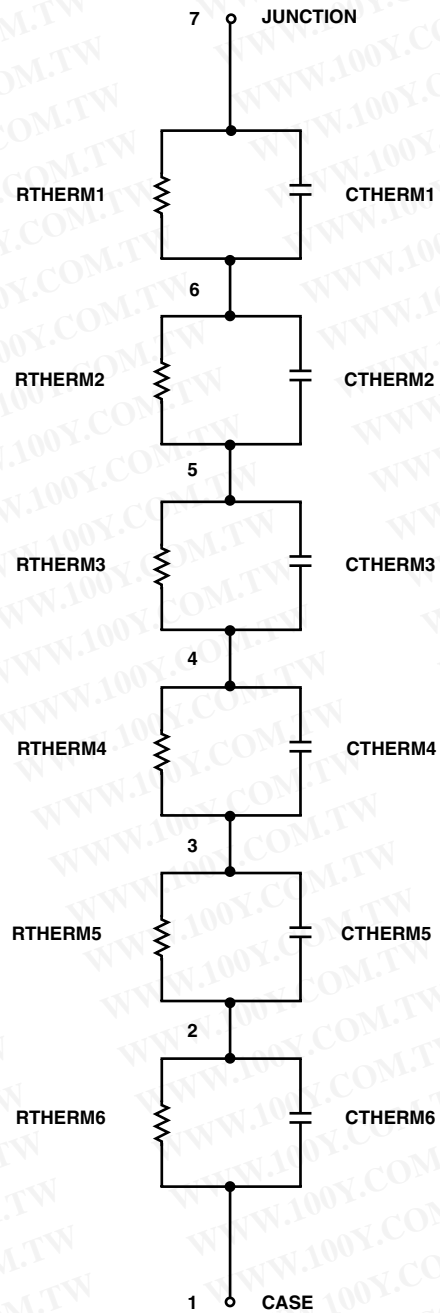



## TRADEMARKS

The following are registered and unregistered trademarks Fairchild Semiconductor owns or is authorized to use and is not intended to be an exhaustive list of all such trademarks.

ACE <sub>x</sub> <sup>TM</sup>	FAST <sup>®</sup>	OPTOLOGIC <sup>TM</sup>	SMART START <sup>TM</sup>	VCX <sup>TM</sup>
Bottomless <sup>TM</sup>	FAST <sub>r</sub> <sup>TM</sup>	OPTOPLANAR <sup>TM</sup>	STAR*POWER <sup>TM</sup>	
CoolFET <sup>TM</sup>	FRFET <sup>TM</sup>	PACMAN <sup>TM</sup>	Stealth <sup>TM</sup>	
CROSSVOLT <sup>TM</sup>	GlobalOptoisolator <sup>TM</sup>	POP <sup>TM</sup>	SuperSOT <sup>TM</sup> -3	
DenseTrench <sup>TM</sup>	GTO <sup>TM</sup>	Power247 <sup>TM</sup>	SuperSOT <sup>TM</sup> -6	
DOMET <sup>TM</sup>	HiSeC <sup>TM</sup>	PowerTrench <sup>®</sup>	SuperSOT <sup>TM</sup> -8	
EcoSPARK <sup>TM</sup>	ISOPLANAR <sup>TM</sup>	QFET <sup>TM</sup>	SyncFET <sup>TM</sup>	
E <sup>2</sup> CMOS <sup>TM</sup>	LittleFET <sup>TM</sup>	QST <sup>TM</sup>	TinyLogic <sup>TM</sup>	
EnSigna <sup>TM</sup>	MicroFET <sup>TM</sup>	QT Optoelectronics <sup>TM</sup>	TruTranslation <sup>TM</sup>	
FACT <sup>TM</sup>	MicroPak <sup>TM</sup>	Quiet Series <sup>TM</sup>	UHC <sup>TM</sup>	
FACT Quiet Series <sup>TM</sup>	MICROWIRE <sup>TM</sup>	SILENT SWITCHER <sup>®</sup>	UltraFET <sup>®</sup>	

STAR\*POWER is used under license

## DISCLAIMER

FAIRCHILD SEMICONDUCTOR RESERVES THE RIGHT TO MAKE CHANGES WITHOUT FURTHER NOTICE TO ANY PRODUCTS HEREIN TO IMPROVE RELIABILITY, FUNCTION OR DESIGN. FAIRCHILD DOES NOT ASSUME ANY LIABILITY ARISING OUT OF THE APPLICATION OR USE OF ANY PRODUCT OR CIRCUIT DESCRIBED HEREIN; NEITHER DOES IT CONVEY ANY LICENSE UNDER ITS PATENT RIGHTS, NOR THE RIGHTS OF OTHERS.

## LIFE SUPPORT POLICY

FAIRCHILD'S PRODUCTS ARE NOT AUTHORIZED FOR USE AS CRITICAL COMPONENTS IN LIFE SUPPORT DEVICES OR SYSTEMS WITHOUT THE EXPRESS WRITTEN APPROVAL OF FAIRCHILD SEMICONDUCTOR CORPORATION.

As used herein:

1. Life support devices or systems are devices or systems which, (a) are intended for surgical implant into the body, or (b) support or sustain life, or (c) whose failure to perform when properly used in accordance with instructions for use provided in the labeling, can be reasonably expected to result in significant injury to the user.
2. A critical component is any component of a life support device or system whose failure to perform can be reasonably expected to cause the failure of the life support device or system, or to affect its safety or effectiveness.

## PRODUCT STATUS DEFINITIONS

### Definition of Terms

Datasheet Identification	Product Status	Definition
Advance Information	Formative or In Design	This datasheet contains the design specifications for product development. Specifications may change in any manner without notice.
Preliminary	First Production	This datasheet contains preliminary data, and supplementary data will be published at a later date. Fairchild Semiconductor reserves the right to make changes at any time without notice in order to improve design.
No Identification Needed	Full Production	This datasheet contains final specifications. Fairchild Semiconductor reserves the right to make changes at any time without notice in order to improve design.
Obsolete	Not In Production	This datasheet contains specifications on a product that has been discontinued by Fairchild semiconductor. The datasheet is printed for reference information only.