

HD74HC4066

Quad Analog Switches/Quad Multiplexers

勝特力材料 886-3-5753170
 勝特力电子(上海) 86-21-54151736
 勝特力电子(深圳) 86-755-83298787
[Http://www.100y.com.tw](http://www.100y.com.tw)

REJ03D0651-0200
 (Previous ADE-205-538)
 Rev.2.00
 Mar 30, 2006

Description

This switch has low “on” resistance and low “off” leakage. It is a bidirectional switch, thus any analog input may be used as an output and vice-versa. Also the HD74HC4066 switch contains linearization circuitry which lowers the “on” resistance and increases switch linearity. The HD74HC4066 device allows control of up to 12 V (peak) analog signals with digital control signals of the same range. Each switch has its own control input which disables each switch when low.

Features

- High Speed Operation
- Wide Operating Voltage: $V_{CC} = 2$ to 6 V
- Low Quiescent Supply Current: I_{CC} (static) = $1 \mu\text{A}$ max ($T_a = 25^\circ\text{C}$)
- Ordering Information

Part Name	Package Type	Package Code (Previous Code)	Package Abbreviation	Taping Abbreviation (Quantity)
HD74HC4066P	DILP-14 pin	PRDP0014AB-B (DP-14AV)	P	—
HD74HC4066FPEL	SOP-14 pin (JEITA)	PRSP0014DF-B (FP-14DAV)	FP	EL (2,000 pcs/reel)
HD74HC4066RPEL	SOP-14 pin (JEDEC)	PRSP0014DE-A (FP-14DNV)	RP	EL (2,500 pcs/reel)
HD74HC4066TELL	TSSOP-14 pin	PTSP0014JA-B (TTP-14DV)	T	ELL (2,000 pcs/reel)

Note: Please consult the sales office for the above package availability.

Function Table

Control	Switch
L	OFF
H	ON

$GND \leq V_{in} \leq V_{CC}$
 $GND \leq V_{out} \leq V_{CC}$

Pin Arrangement

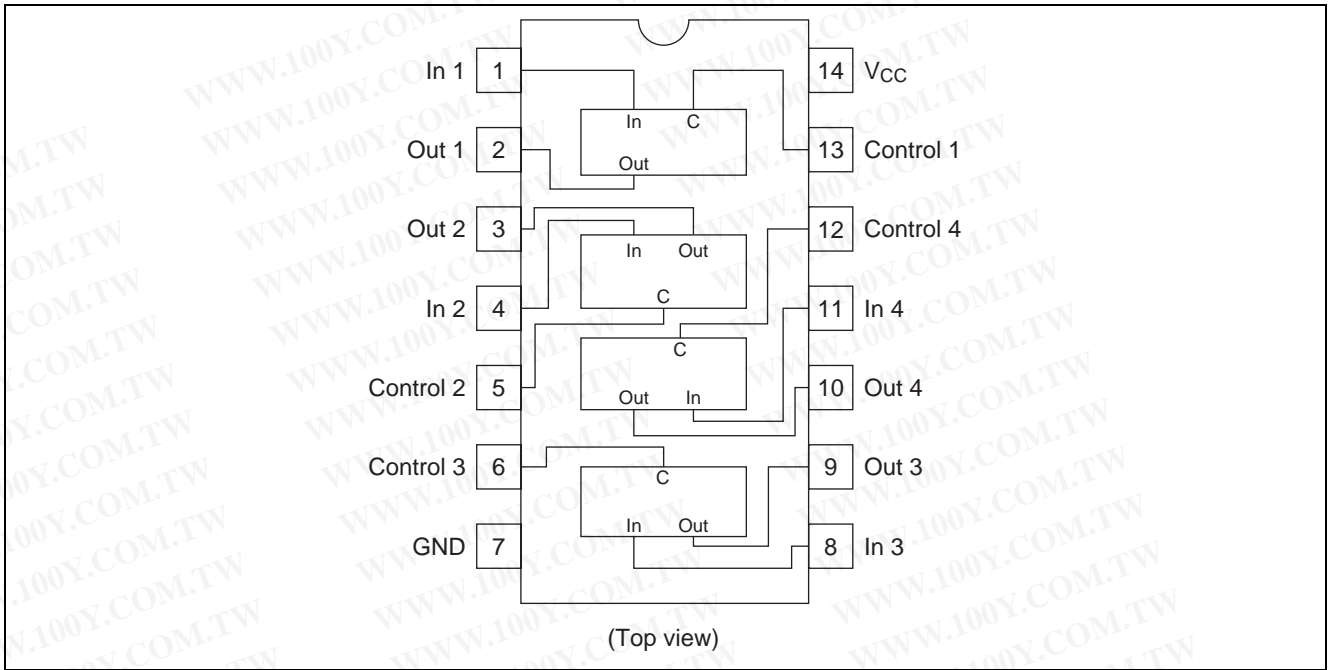

Logic Diagram

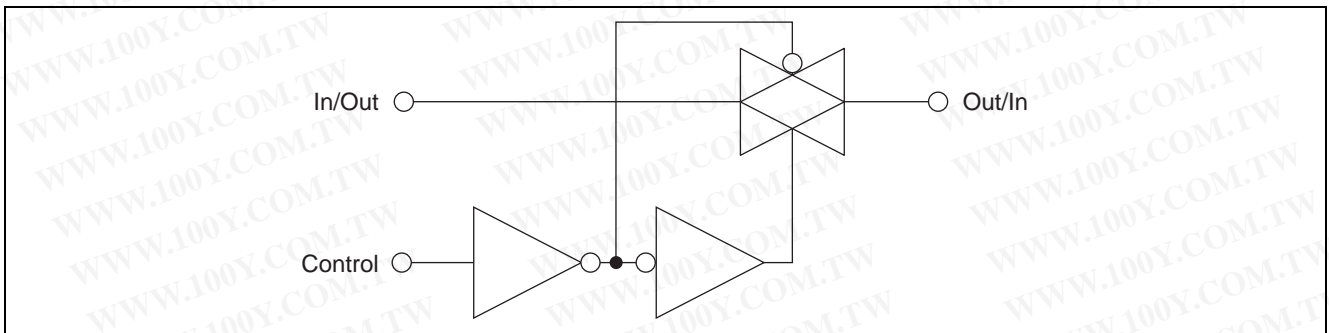

Absolute Maximum Ratings

Item	Symbol	Rating	Unit
Supply voltage	V_{CC}	-0.5 to +7.0	V
Control input voltage	V_C	-0.5 to $V_{CC} + 0.5$	V
Switch I/O voltage	$V_{IN/OUT}$	-0.5 to $V_{CC} + 0.5$	V
Supply current	(V_{CC})	I_{CC}	+50
	(GND)	I_{GND}	-50
Switch I/O current (per pin)	$I_{IN/OUT}$	± 25	mA
Control input diode current	I_{IK}	± 20	mA
Switch I/O diode current	I_{IOK}	± 20	mA
Power dissipation	P_T	500	mW
Storage temperature range	T_{stg}	-65 to +150	$^{\circ}C$

勝特力材料 886-3-5753170
 勝特力电子(上海) 86-21-54151736
 勝特力电子(深圳) 86-755-83298787
[Http://www.100y.com.tw](http://www.100y.com.tw)

Recommended Operating Conditions

Item	Symbol	Min	Typ	Max	Unit	
Supply voltage	V_{CC}	2	—	6	V	
Control input voltage	V_C	0	—	V_{CC}	V	
Switch I/O voltage	$V_{IN/OUT}$	0	—	V_{CC}	V	
Operating temperature	T_{opr}	-40	—	+85	°C	
Input rise/fall time	$V_{CC} = 2.0\text{ V}$	t_r, t_f	0	—	1000	ns
	$V_{CC} = 4.5\text{ V}$		0	—	500	ns
	$V_{CC} = 6.0\text{ V}$		0	—	400	ns

Electrical Characteristics

Item	Symbol	V_{CC} (V)	$T_a = 25^\circ\text{C}$			$T_a = -40\text{ to }+85^\circ\text{C}$		Unit	Test Conditions
			Min	Typ	Max	Min	Max		
Control input voltage	V_{IH}	2.0	1.5	—	—	1.5	—	V	
		4.5	3.15	—	—	3.15	—		
		6.0	4.2	—	—	4.2	—		
	V_{IL}	2.0	—	—	0.5	—	0.5	V	
		4.5	—	—	1.35	—	1.35		
		6.0	—	—	1.8	—	1.8		
“ON” resistance	R_{ON}	2.0	—	2000	5000	—	6250	Ω	$V_C = V_{IH}$ $V_{in} = 0\text{ to }V_{CC}$ $I_{in/out} = 1\text{ mA}$
		4.5	—	100	200	—	250		
		6.0	—	60	170	—	210		
Δ ON resistance between any two channels	ΔR_{ON}	2.0	—	50	—	—	—	Ω	$V_C = V_{IH}$, $I_{in/out} = 1\text{ mA}$ between any two channels
		4.5	—	3	—	—	—		
		6.0	—	2	—	—	—		
OFF channel leakage current (switch off)	$I_{S(OFF)}$	6.0	—	—	± 0.1	—	± 1.0	μA	$V_C = V_{IL}$ $V_{IN} = V_{CC}$, $V_{out} = \text{GND}$ or, $V_{in} = \text{GND}$, $V_{out} = V_{CC}$
OFF channel leakage current (switch on)	$I_{S(ON)}$	6.0	—	—	± 0.1	—	± 1.0	μA	$V_C = V_{IH}$ $V_{in} = V_{CC}$ or GND
Control input current	I_{in}	6.0	—	—	± 0.1	—	± 1.0	μA	$V_{in} = V_{CC}$ or GND
Quiescent supply current	I_{CC}	6.0	—	—	1.0	—	10.0	μA	$V_{in} = V_{CC}$ or GND

勝特力材料 886-3-5753170
 勝特力电子(上海) 86-21-54151736
 勝特力电子(深圳) 86-755-83298787
[Http://www.100y.com.tw](http://www.100y.com.tw)

Switching Characteristics ($C_L = 50 \text{ pF}$, Input $t_r = t_f = 6 \text{ ns}$, $V_{EE} = \text{GND}$)

Item	Symbol	V_{CC} (V)	$T_a = 25^\circ\text{C}$			$T_a = -40 \text{ to } +85^\circ\text{C}$		Unit	Test Conditions
			Min	Typ	Max	Min	Max		
Propagation delay time	t_{PLH}	2.0	—	25	60	—	75	ns	$R_L = 10 \text{ k}\Omega$ Switch input to switch output
		4.5	—	6	12	—	15		
		6.0	—	5	10	—	13		
	t_{PHL}	2.0	—	25	60	—	75		
		4.5	—	6	12	—	15		
		6.0	—	5	10	—	13		
Propagation delay time	t_{PLH}	2.0	—	—	50	—	65	ns	$R_L = 10 \text{ k}\Omega$
	t_{PHT}	4.5	—	4	10	—	13		
	6.0	—	—	9	—	11			
Output enable time	t_{ZH}	2.0	—	—	115	—	145	ns	$R_L = 1 \text{ k}\Omega$
		4.5	—	10	23	—	29		
		6.0	—	—	20	—	25		
Output disable time	t_{LZ} t_{HZ}	2.0	—	—	115	—	145	ns	$R_L = 1 \text{ k}\Omega$
		4.5	—	14	23	—	29		
		6.0	—	—	20	—	25		
Sine wave distortion		4.5	—	0.05	—	—	—	%	$R_L = 10 \text{ k}\Omega$, $C_L = 50 \text{ pF}$, $f_{IN} = 1 \text{ kHz}$
Band width (-3 dB)		4.5	—	30	—	—	—	MHz	$R_L = 600 \Omega$, $C_L = 50 \text{ pF}$, $20 \log_{10} V_{out}/V_{in} = -3\text{dB}$
Feed through attenuation		4.5	—	-50	—	—	—	dB	$R_L = 600 \Omega$, $C_L = 50 \text{ pF}$, $f_{IN} = 1 \text{ MHz}$
Cross talk between control input to signal I/O		2.0	—	25	—	—	—	mA	$R_L = 600 \Omega$, $C_L = 50 \text{ pF}$, $f_{IN} = 1 \text{ MHz}$
		4.5	—	60	—	—	—		
		6.0	—	75	—	—	—		
Cross talk between any two switches		4.5	—	-50	—	—	—	dB	$R_L = 600 \Omega$, $C_L = 50 \text{ pF}$, $f_{IN} = 1 \text{ MHz}$
Maximum control frequency		2.0	—	20	—	—	—	MHz	$R_L = 1 \text{ k}\Omega$, $C_L = 15 \text{ pF}$, $V_{out} = 1/2 (V_{CC})$
		4.5	—	30	—	—	—		
		6.0	—	30	—	—	—		
Control input capacitance	C_{in}		—	5	10	—	10	pF	
Switch I/O capacitance	$C_{in/out}$		—	6	—	—	—	pF	
Feed through capacitance	$C_{in/out}$		—	0.5	—	—	—	pF	
Power dissipation capacitance	C_{PD}		—	13	—	—	—	pF	

勝特力材料 886-3-5753170
 勝特力电子(上海) 86-21-54151736
 勝特力电子(深圳) 86-755-83298787
[Http://www.100y.com.tw](http://www.100y.com.tw)

Test Circuit

Maximum Control Frequency

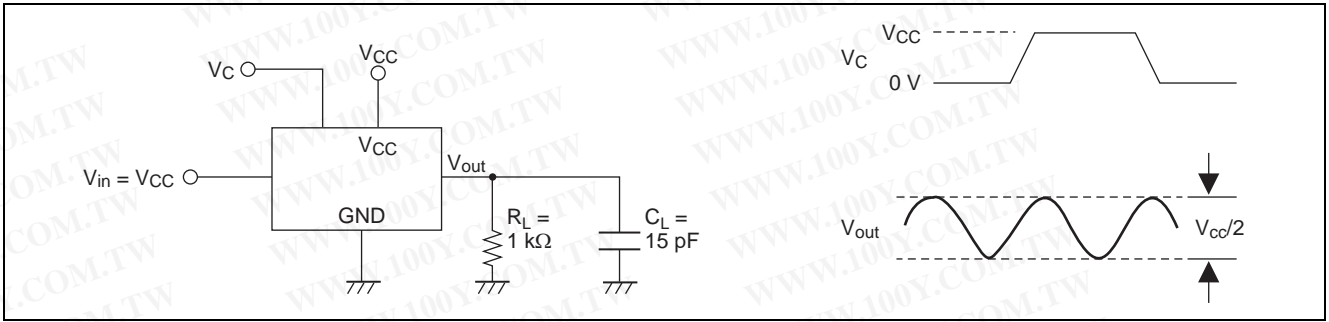

Cross talk (Control Input to Switch Output)

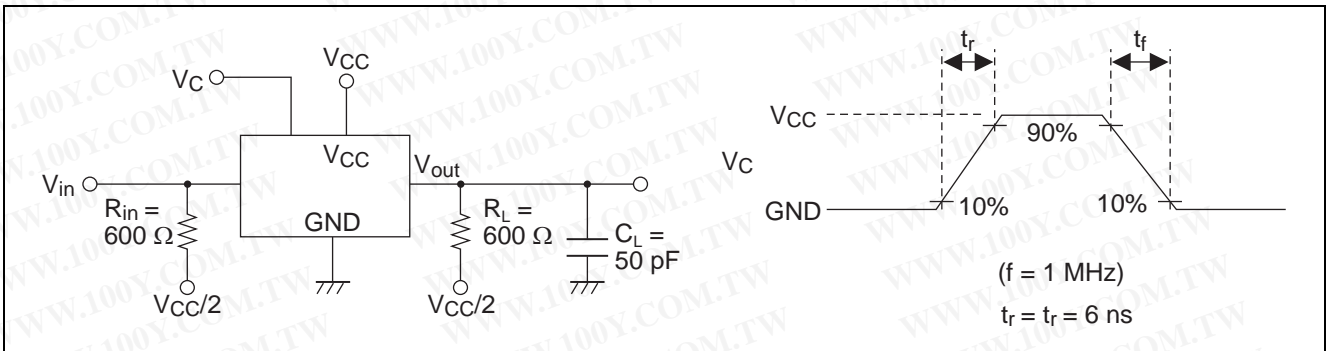

Feed through Attenuation

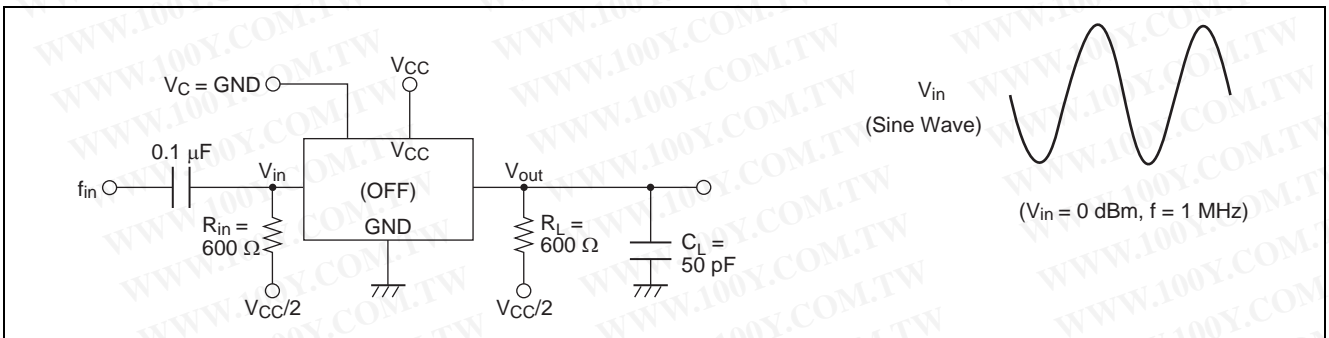

Sine Wave Distortion

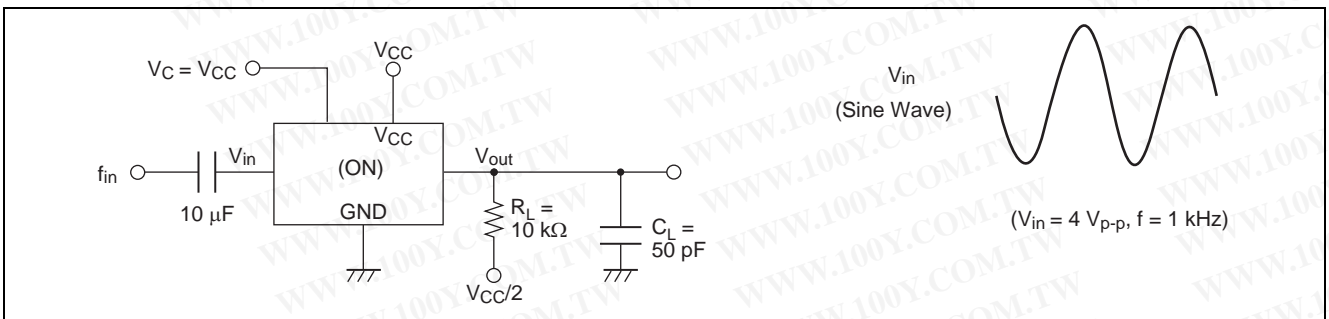

勝特力材料 886-3-5753170
 勝特力电子(上海) 86-21-54151736
 勝特力电子(深圳) 86-755-83298787
[Http://www.100y.com.tw](http://www.100y.com.tw)

C_{in}, C_{out}, C_{in-out} (Input, Output, and Feed through Capacitance)

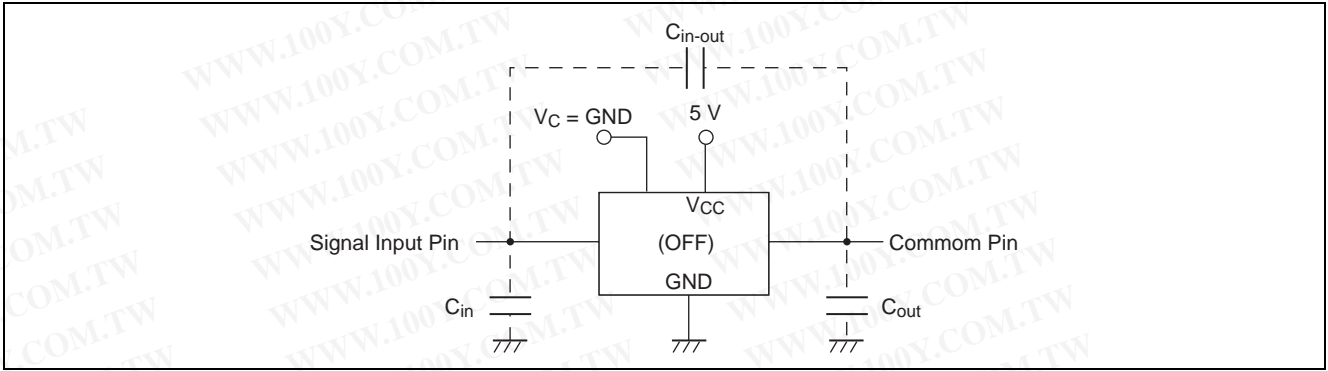

Switch Frequency Response Band Width (-3dB)

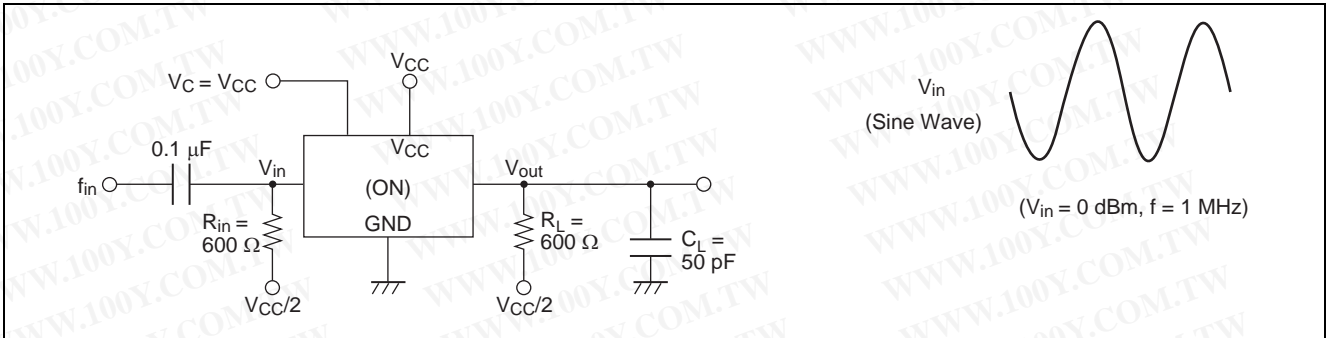

R_{ON}: ON Resistance

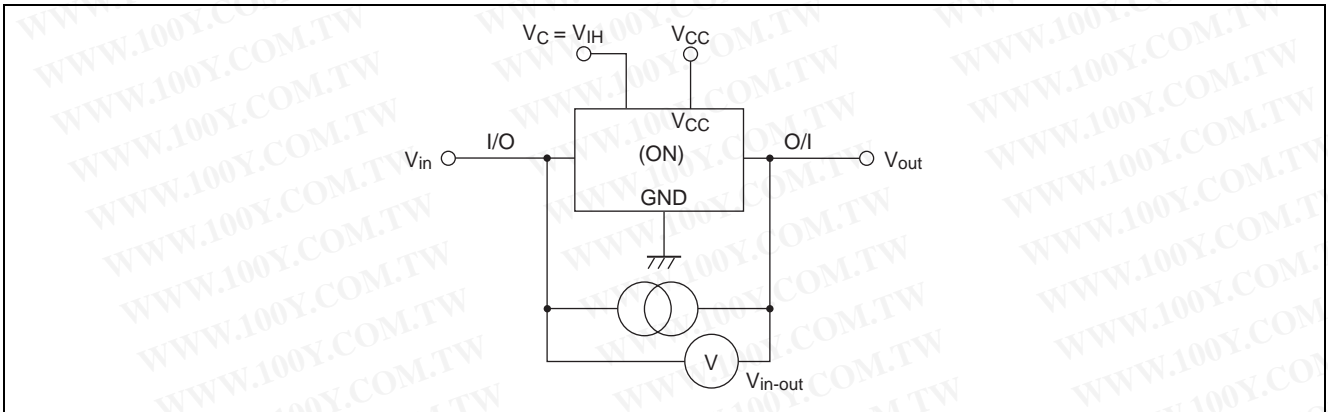

I_s (OFF): OFF Channel Leakage Current (Switch OFF)

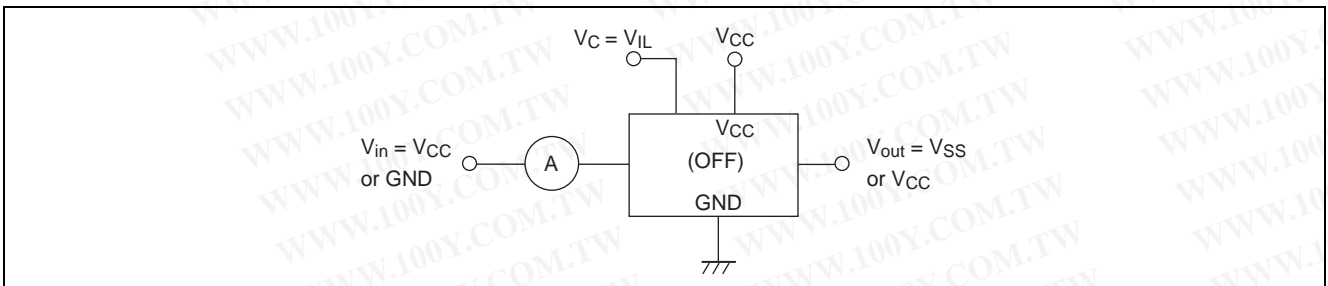

勝特力材料 886-3-5753170
 勝特力电子(上海) 86-21-54151736
 勝特力电子(深圳) 86-755-83298787
 Http://www.100y.com.tw

I_s (ON): OFF Channel Leakage Current (Switch ON)

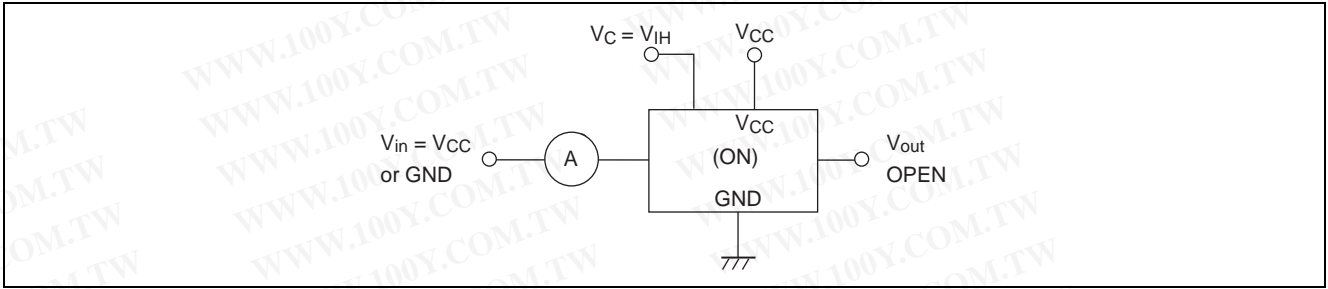

t_{PLH} , t_{PHL} : Propagation Delay Time (Switch Input to Switch Output)

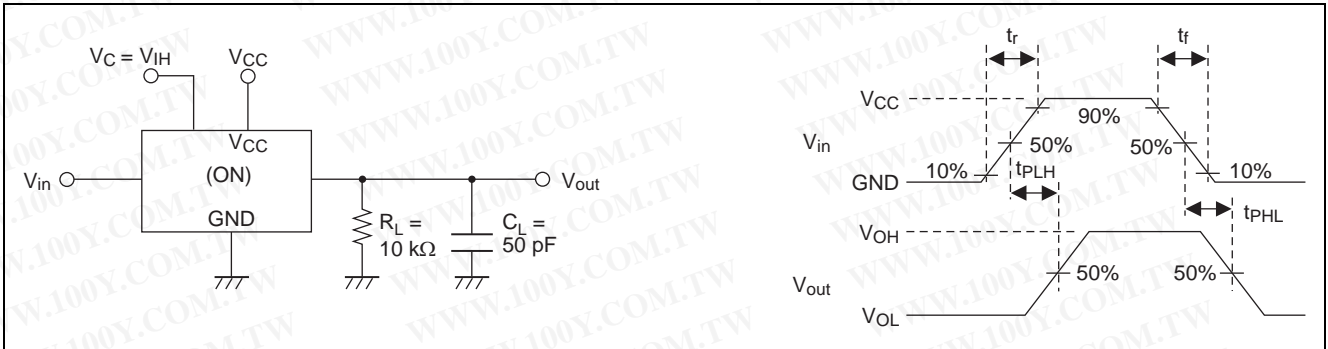

t_{ZH} , t_{ZL}/t_{HZ} , t_{LZ} : Output Enable and Disable Time

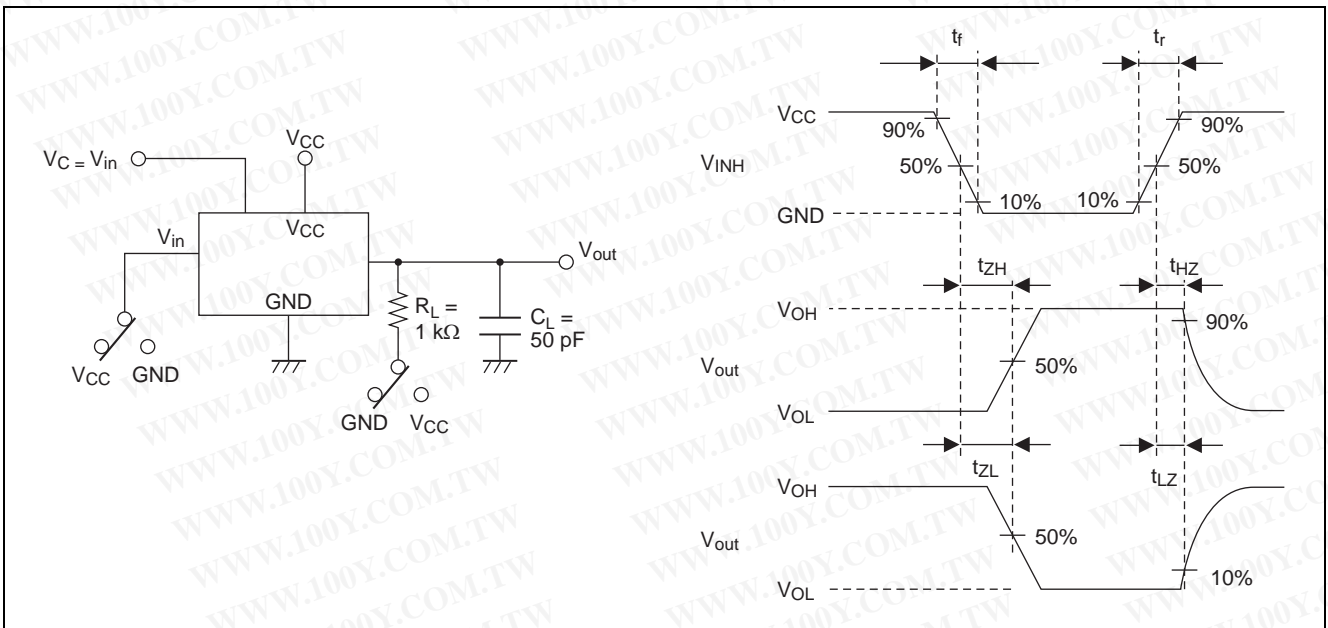

勝特力材料 86-3-5753170
 勝特力电子(上海) 86-21-54151736
 勝特力电子(深圳) 86-755-83298787
[Http://www.100y.com.tw](http://www.100y.com.tw)

Package Dimensions

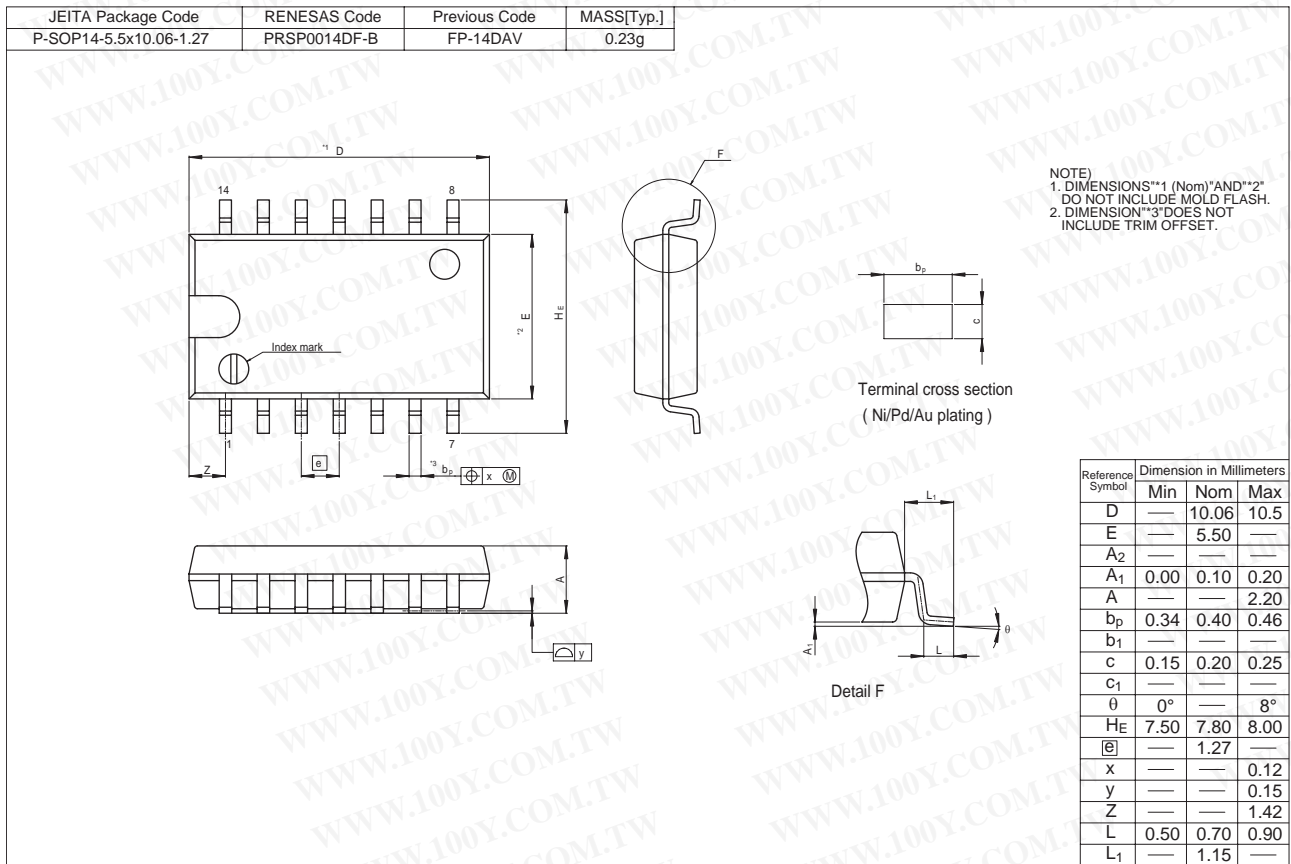
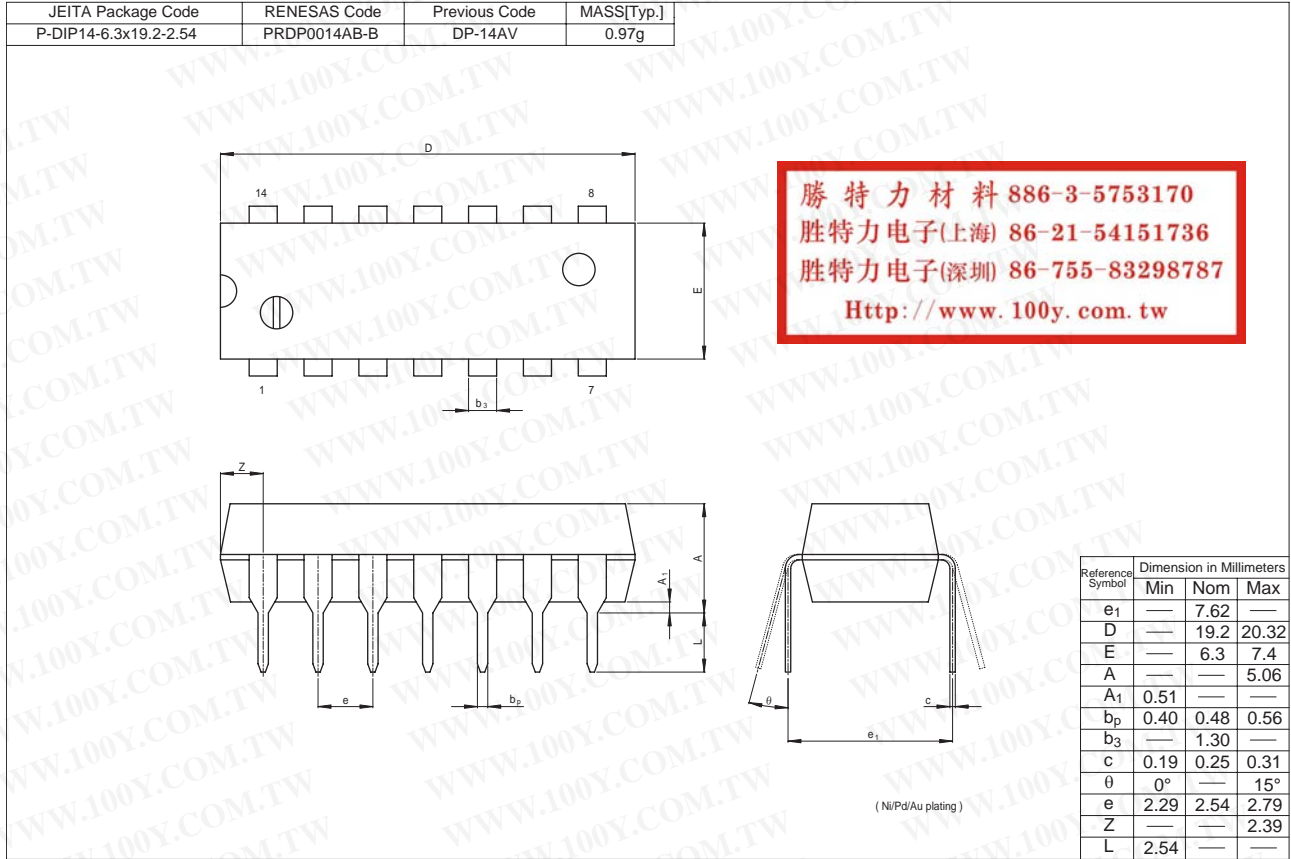

HD74HC4066

JEITA Package Code	RENESAS Code	Previous Code	MASS[Typ.]
P-SOP14-3.95x8.65-1.27	PRSP0014DE-A	FP-14DNV	0.13g

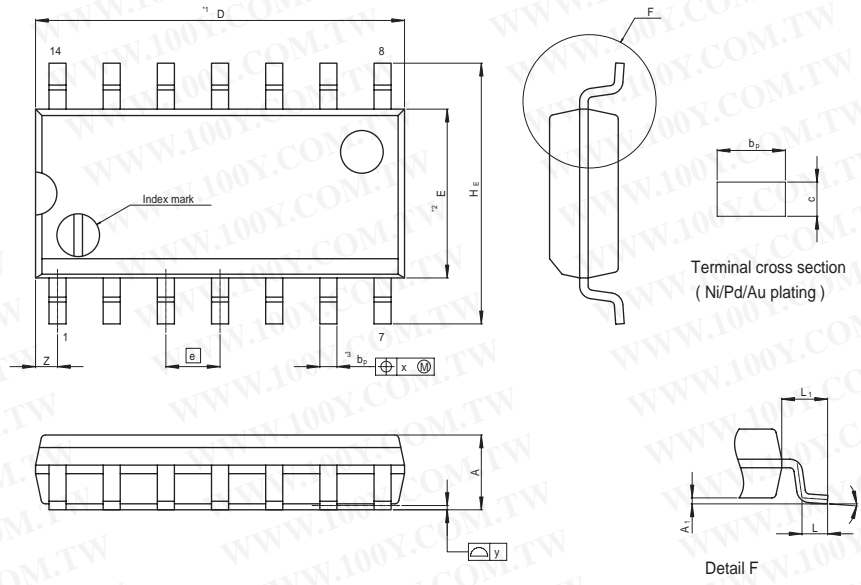

NOTE)
 1. DIMENSIONS**1 (Nom)**AND**2*
 DO NOT INCLUDE MOLD FLASH.
 2. DIMENSION**3*DOES NOT
 INCLUDE TRIM OFFSET.

Reference Symbol	Dimension in Millimeters		
	Min	Nom	Max
D	—	8.65	9.05
E	—	3.95	—
A ₂	—	—	—
A ₁	0.10	0.14	0.25
A	—	—	1.75
b _p	0.34	0.40	0.46
b ₁	—	—	—
c	0.15	0.20	0.25
c ₁	—	—	—
θ	0°	—	8°
HE	5.80	6.10	6.20
⓪	—	1.27	—
x	—	—	0.25
y	—	—	0.15
Z	—	—	0.635
L	0.40	0.60	1.27
L ₁	—	—	1.08

JEITA Package Code	RENESAS Code	Previous Code	MASS[Typ.]
P-TSSOP14-4.4x5-0.65	PTSP0014JA-B	TTP-14DV	0.05g

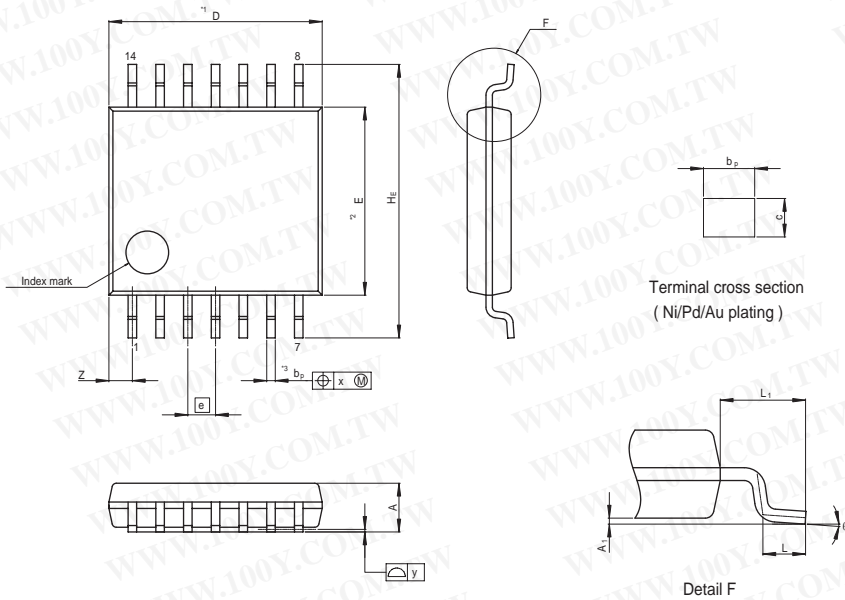

NOTE)
 1. DIMENSIONS**1 (Nom)**AND**2*
 DO NOT INCLUDE MOLD FLASH.
 2. DIMENSION**3*DOES NOT
 INCLUDE TRIM OFFSET.

Reference Symbol	Dimension in Millimeters		
	Min	Nom	Max
D	—	5.00	5.30
E	—	4.40	—
A ₂	—	—	—
A ₁	0.03	0.07	0.10
A	—	—	1.10
b _p	0.15	0.20	0.25
b ₁	—	—	—
c	0.10	0.15	0.20
c ₁	—	—	—
θ	0°	—	8°
HE	6.20	6.40	6.60
⓪	—	0.65	—
x	—	—	0.13
y	—	—	0.10
Z	—	—	0.83
L	0.4	0.5	0.6
L ₁	—	—	1.0

勝特力材料 886-3-5753170
勝特力电子(上海) 86-21-54151736
勝特力电子(深圳) 86-755-83298787
Http://www.100y.com.tw

勝特力材料 886-3-5753170
勝特力电子(上海) 86-21-54151736
勝特力电子(深圳) 86-755-83298787
[Http://www.100y.com.tw](http://www.100y.com.tw)

Renesas Technology Corp. Sales Strategic Planning Div. Nippon Bldg., 2-6-2, Ohte-machi, Chiyoda-ku, Tokyo 100-0004, Japan

Keep safety first in your circuit designs!

1. Renesas Technology Corp. puts the maximum effort into making semiconductor products better and more reliable, but there is always the possibility that trouble may occur with them. Trouble with semiconductors may lead to personal injury, fire or property damage. Remember to give due consideration to safety when making your circuit designs, with appropriate measures such as (i) placement of substitutive, auxiliary circuits, (ii) use of nonflammable material or (iii) prevention against any malfunction or mishap.

Notes regarding these materials

1. These materials are intended as a reference to assist our customers in the selection of the Renesas Technology Corp. product best suited to the customer's application; they do not convey any license under any intellectual property rights, or any other rights, belonging to Renesas Technology Corp. or a third party.
2. Renesas Technology Corp. assumes no responsibility for any damage, or infringement of any third-party's rights, originating in the use of any product data, diagrams, charts, programs, algorithms, or circuit application examples contained in these materials.
3. All information contained in these materials, including product data, diagrams, charts, programs and algorithms represents information on products at the time of publication of these materials, and are subject to change by Renesas Technology Corp. without notice due to product improvements or other reasons. It is therefore recommended that customers contact Renesas Technology Corp. or an authorized Renesas Technology Corp. product distributor for the latest product information before purchasing a product listed herein.
The information described here may contain technical inaccuracies or typographical errors.
Renesas Technology Corp. assumes no responsibility for any damage, liability, or other loss rising from these inaccuracies or errors.
Please also pay attention to information published by Renesas Technology Corp. by various means, including the Renesas Technology Corp. Semiconductor home page (<http://www.renesas.com>).
4. When using any or all of the information contained in these materials, including product data, diagrams, charts, programs, and algorithms, please be sure to evaluate all information as a total system before making a final decision on the applicability of the information and products. Renesas Technology Corp. assumes no responsibility for any damage, liability or other loss resulting from the information contained herein.
5. Renesas Technology Corp. semiconductors are not designed or manufactured for use in a device or system that is used under circumstances in which human life is potentially at stake. Please contact Renesas Technology Corp. or an authorized Renesas Technology Corp. product distributor when considering the use of a product contained herein for any specific purposes, such as apparatus or systems for transportation, vehicular, medical, aerospace, nuclear, or undersea repeater use.
6. The prior written approval of Renesas Technology Corp. is necessary to reprint or reproduce in whole or in part these materials.
7. If these products or technologies are subject to the Japanese export control restrictions, they must be exported under a license from the Japanese government and cannot be imported into a country other than the approved destination.
Any diversion or reexport contrary to the export control laws and regulations of Japan and/or the country of destination is prohibited.
8. Please contact Renesas Technology Corp. for further details on these materials or the products contained therein.



RENESAS SALES OFFICES

<http://www.renesas.com>

Refer to "<http://www.renesas.com/en/network>" for the latest and detailed information.

Renesas Technology America, Inc.

450 Holger Way, San Jose, CA 95134-1368, U.S.A
Tel: <1> (408) 382-7500, Fax: <1> (408) 382-7501

Renesas Technology Europe Limited

Dukes Meadow, Millboard Road, Bourne End, Buckinghamshire, SL8 5FH, U.K.
Tel: <44> (1628) 585-100, Fax: <44> (1628) 585-900

Renesas Technology (Shanghai) Co., Ltd.

Unit 204, 205, AZIACenter, No.1233 Lujiazui Ring Rd, Pudong District, Shanghai, China 200120
Tel: <86> (21) 5877-1818, Fax: <86> (21) 6887-7898

Renesas Technology Hong Kong Ltd.

7th Floor, North Tower, World Finance Centre, Harbour City, 1 Canton Road, Tsimshatsui, Kowloon, Hong Kong
Tel: <852> 2265-6688, Fax: <852> 2730-6071

Renesas Technology Taiwan Co., Ltd.

10th Floor, No.99, Fushing North Road, Taipei, Taiwan
Tel: <886> (2) 2715-2888, Fax: <886> (2) 2713-2999

Renesas Technology Singapore Pte. Ltd.

1 Harbour Front Avenue, #06-10, Keppel Bay Tower, Singapore 098632
Tel: <65> 6213-0200, Fax: <65> 6278-8001

Renesas Technology Korea Co., Ltd.

Kukje Center Bldg. 18th Fl., 191, 2-ka, Hangang-ro, Yongsan-ku, Seoul 140-702, Korea
Tel: <82> (2) 796-3115, Fax: <82> (2) 796-2145

Renesas Technology Malaysia Sdn. Bhd

Unit 906, Block B, Menara Amcorp, Amcorp Trade Centre, No.18, Jalan Persiaran Barat, 46050 Petaling Jaya, Selangor Darul Ehsan, Malaysia
Tel: <603> 7955-9390, Fax: <603> 7955-9510