

8-Bit Single-Chip Microcontroller

SAB 8052B Microcontroller with factory mask programmable ROM (8K)

SAB 8032B Microcontroller for external ROM

- Versions for 12 MHz / 16 MHz / 20 MHz operating frequency
- 8 K × 8 ROM (SAB 8052B only)
- 256 × 8 RAM
- Four 8-bit ports, 32 I/O lines
- Three 16-bit timer/event counters
- High-performance full-duplex serial channel with flexible transmit/receive baud rate capability
- External memory expandable up to 128 Kbytes
- Boolean processor
- Most instructions execute in:
 - 1 μs instruction cycle time at 12 MHz
 - 750 ns instruction cycle time at 16 MHz
 - 600 ns instruction cycle time at 20 MHz
- Multiply and divide in 4 μs/3 μs/2.4 μs
- Six interrupt vectors, two priority levels
- RAM power-down supply
- Packages P-DIP-40 and PL-CC-44
- Full backward compatibility with SAB 8051/8031
- Three temperature ranges available
 - 0 to 70 °C
 - 40 to 85 °C
 - 40 to 110 °C

勝特力材料 886-3-5753170
 勝特力电子(上海) 86-21-54151736
 勝特力电子(深圳) 86-755-83298787
[Http://www.100y.com.tw](http://www.100y.com.tw)

4

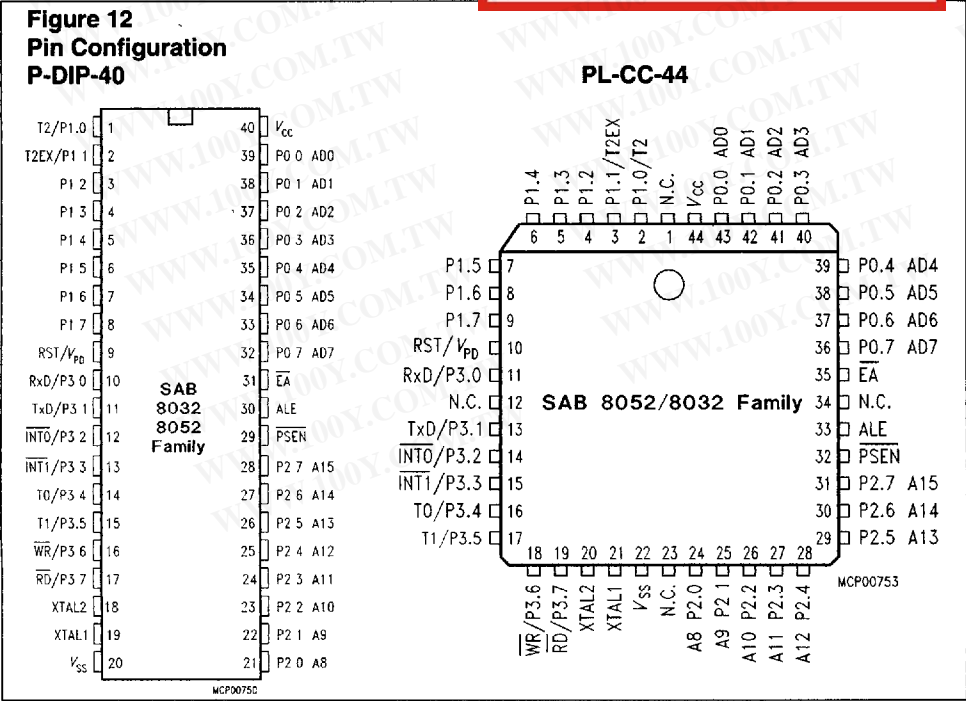

SAB 8052/8032 Family

The SAB 8052/8032 family are standalone, high-performance single-chip microcontrollers fabricated in +5V advanced N-channel, silicon-gate Siemens MYMOS technology, packaged in a 40-pin plastic dual-in-line package (P-DIP-40) or 44-pin plastic leaded chip carrier (PL-CC-44) package. It is backwardly compatible with the SAB 8051A/8031A and provides the hardware features, architectural enhancements, and instructions that are necessary to make it a powerful and cost-effective controller for applications requiring up to 64 Kbytes of program memory and/or up to 64 Kbytes of data memory.

The controllers of the SAB 8052 / 8032 family contain a non-volatile 8 K × 8 read-only program memory, a volatile 256 × 8 read/

write data memory, 32 I/O lines, three 16-bit timer/counters, a six-source, two-priority-level nested interrupt structure, a serial I/O port for either multiprocessor communications, I/O expansion, or full-duplex UART, as well as an on-chip oscillator and clock circuits.

For systems that require extra capability, the standard TTL compatible memories and the byte-oriented SAB 8080 and SAB 8085 peripherals can be used to expand the SAB 8052 / 8032 family.

The parts are available for standard temperature range (0 to 70 °C) and extended temperature ranges (-40 to 85 °C and -40 to 110 °C).

Figure 13
SAB 8052 / 8032 family

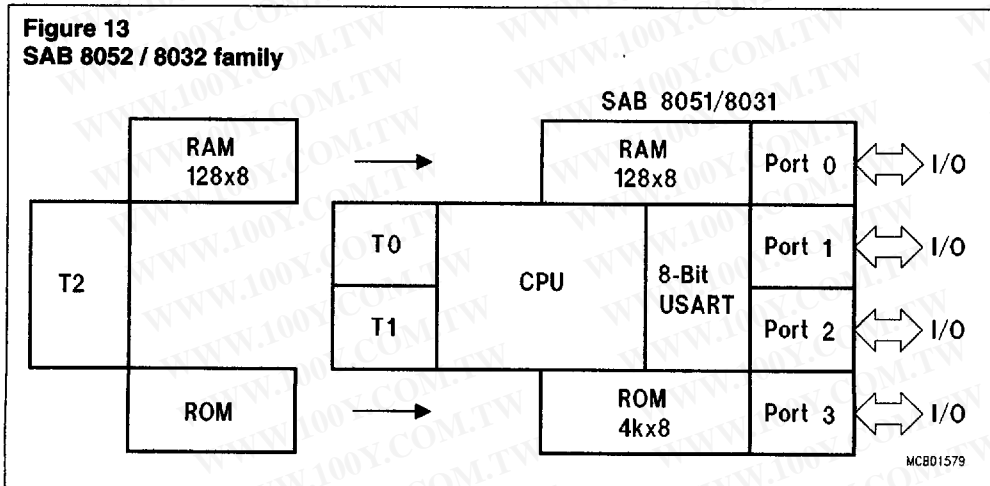

勝特力材料 886-3-5753170
 勝特力电子(上海) 86-21-54151736
 勝特力电子(深圳) 86-755-83298787
[Http://www.100y.com.tw](http://www.100y.com.tw)

Ordering Information

Type	Package	Description (8-bit single- microcontroller)
SAB 8032B-P	P-DIP-40	for external memory, 12 MHz.
SAB 8032B-N	PL-CC-44	
SAB 8032B-16-P	P-DIP-40	for external memory, 16 MHz
SAB 8032B-16-N	PL-CC-44	
SAB 8032B-20-P	P-DIP-4	for external memory, 20 MHz
SAB 8032B-20-N	PL-CC-44	
SAB 8052B-P	P-DIP-40	with 8-KByte mask-programmable ROM, 12 MHz
SAB 8052B-N	PL-CC-44	
SAB 8052B-16-P	P-DIP-40	with 8-KByte mask-programmable ROM, 16 MHz
SAB 8052B-16-N	PL-CC-44	

勝特力材料 886-3-5753170
 勝特力电子(上海) 86-21-54151736
 勝特力电子(深圳) 86-755-83298787
[Http://www.100y.com.tw](http://www.100y.com.tw)

勝特力材料 886-3-5753170
 勝特力电子(上海) 86-21-54151736
 勝特力电子(深圳) 86-755-83298787
[Http://www.100y.com.tw](http://www.100y.com.tw)

Figure 14
 Logic Symbol

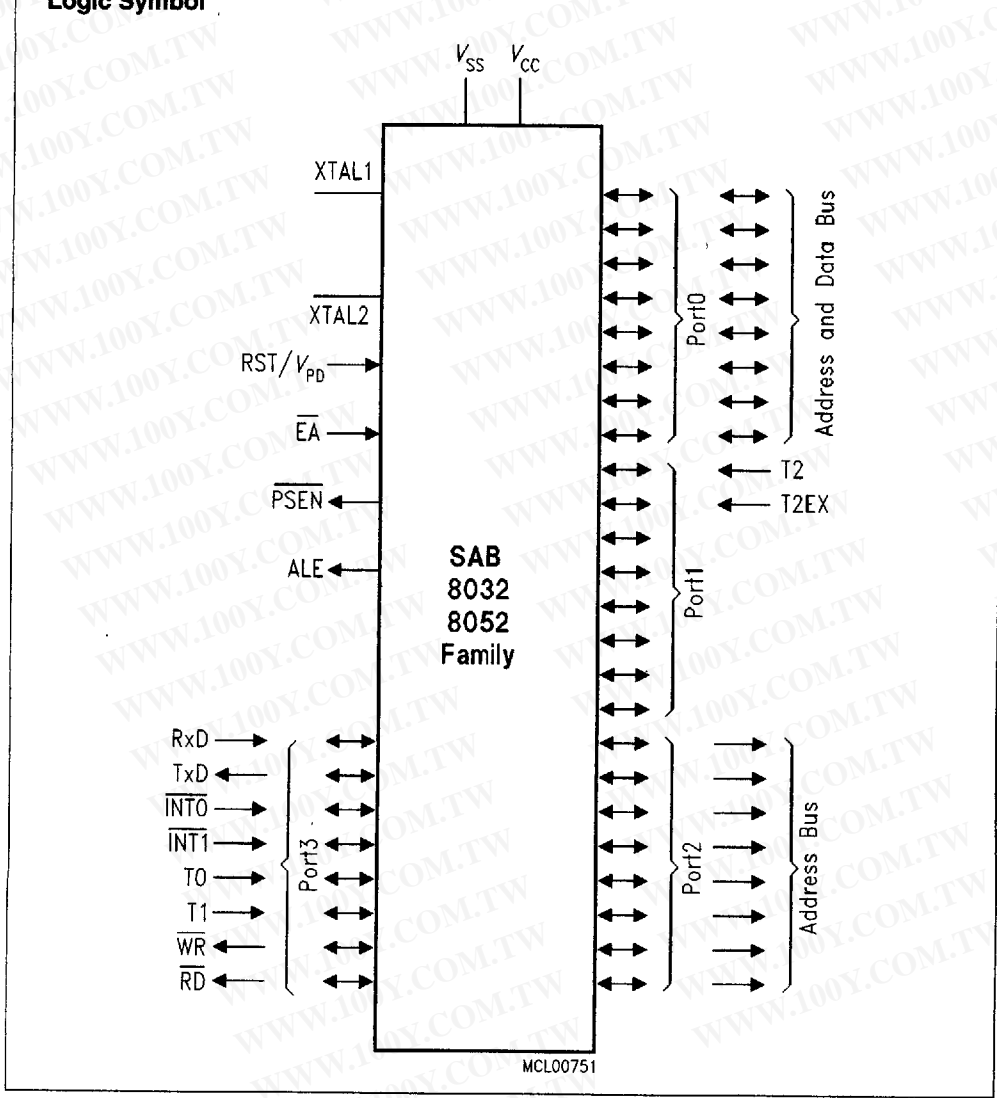

Pin Definitions and Functions

Symbol	Pins		Input (I) Output (O)	Function
	P-DIP-40	PL-CC-44		
P1.0-P1.7	1-8	2-9	I/O	<p>PORT 1 is an 8-bit quasi-bidirectional I/O port. It is used for the low-order address byte during program verification. Port 1 can sink/source four LS TTL loads.</p> <p>Port 1 also contains the timer 2 pins as a secondary function. The output latch corresponding to a secondary function must be programmed to a one (1) for that function to operate. The secondary functions are assigned to the pins of port 1, as follows:</p> <ul style="list-style-type: none"> - T2 (P1.0). Input to counter 2. - T2 (EX (P1.1). Capture/Reload trigger of timer 2.
RST/V _{PD}	9	10	I	<p>RESET input. A high level on this pin resets the SAB 8052B. A small internal pulldown resistor permits power-on reset using only a capacitor connected to V_{CC}. If V_{PD} is held within its spec while V_{CC} drops below spec, V_{PD} will provide standby power to the RAM. When V_{PD} is low, the RAM's current is drawn from V_{CC}.</p>
P3.0-P3.7	10-17	11 13-19	I/O	<p>PORT 3 is an 8-bit quasi-bidirectional I/O port. It also contains the interrupt, timer, serial port and RD and WR pins that are used by various options. The output latch corresponding to a secondary function must be programmed to a one (1) for that function to operate. Port 3 can sink/source four LS TTL loads. The secondary functions are assigned to the pins of port 3, as follows:</p> <ul style="list-style-type: none"> - RxD/data (P3.0). Serial port's receiver data input (asynchronous) or data input/output (synchronous). - TxD/clock (P3.1). Serial port's transmitter data output (asynchronous) or clock output (synchronous). - INTO (P3.2). Interrupt 0 input or gate control input for counter 0. - INT1 (P3.3). Interrupt 1 input or gate control input for counter 1. - T0 (P3.4). Input to counter 0. - T1 (P3.5). Input to counter 1. - WR (P3.6). The write control signal latches the data byte from port 0 into the external data memory. - RD (P3.7). The read control signal enables external data memory to port 0.
XTAL1 XTAL2	19 18	21 20		<p>XTAL 1 input to the oscillator's high gain amplifier. Required when a crystal is used. Connect to V_{SS} when external source is used on XTAL 2.</p> <p>XTAL 2 output from the oscillator's amplifier. Input to the internal timing circuitry. A crystal or external source can be used.</p>
P2.0-P2.7	21-28	24-31	I/O	<p>PORT 2 is an 8-bit quasi-bidirectional I/O port. It also emits the high-order address byte when accessing external memory. It is used for the high-order address and the control signals during program verification. Port 2 can sink/source four LS TTL loads.</p>

勝特力材料 886-3-5753170
 勝特力电子(上海) 86-21-54151736
 勝特力电子(深圳) 86-755-83298787
[Http://www.100y.com.tw](http://www.100y.com.tw)

Pin Definitions and Functions (continued)

Symbol	Pins		Input (I) Output (O)	Function
	P-DIP-40	PL-CC-44		
PSEN	29	32	O	The Program Store Enable output is a control signal that enables the external program memory to the bus during external fetch operations. It is activated every six oscillator periods, except during external data memory accesses. Remains high during internal program execution.
ALE	30	33	O	Provides Address Latch Enable output used for latching the address into external memory during normal operation. It is activated every six oscillator periods except during an external data memory access.
\overline{EA}	31	35	I	External Access enable. When held at a TTL high level, the ROM-versions executes instructions from the internal ROM when the PC points to the internal ROM address space. When held at a TTL low level, the ROM-versions fetch all instructions from external program memory. For the ROM-less versions this pin must be tied low.
P0.0-P0.7	39-32	43-36	I/O	Port 0 is an 8-bit open drain bidirectional I/O port. It is also the multiplexed low-order address and data bus when using external memory. It is used for data output during program verification. Port 0 can sink/source eight LS TTL loads.
Vcc	40	44	-	+ 5 V Power Supply during operation and program verification.
Vss	20	22	-	Circuit Ground potential
NC	-	1,12, 23,34	-	No Connection

勝特力材料 886-3-5753170
 勝特力电子(上海) 86-21-54151736
 勝特力电子(深圳) 86-755-83298787
[Http://www.100y.com.tw](http://www.100y.com.tw)

Figure 15
Block Diagram

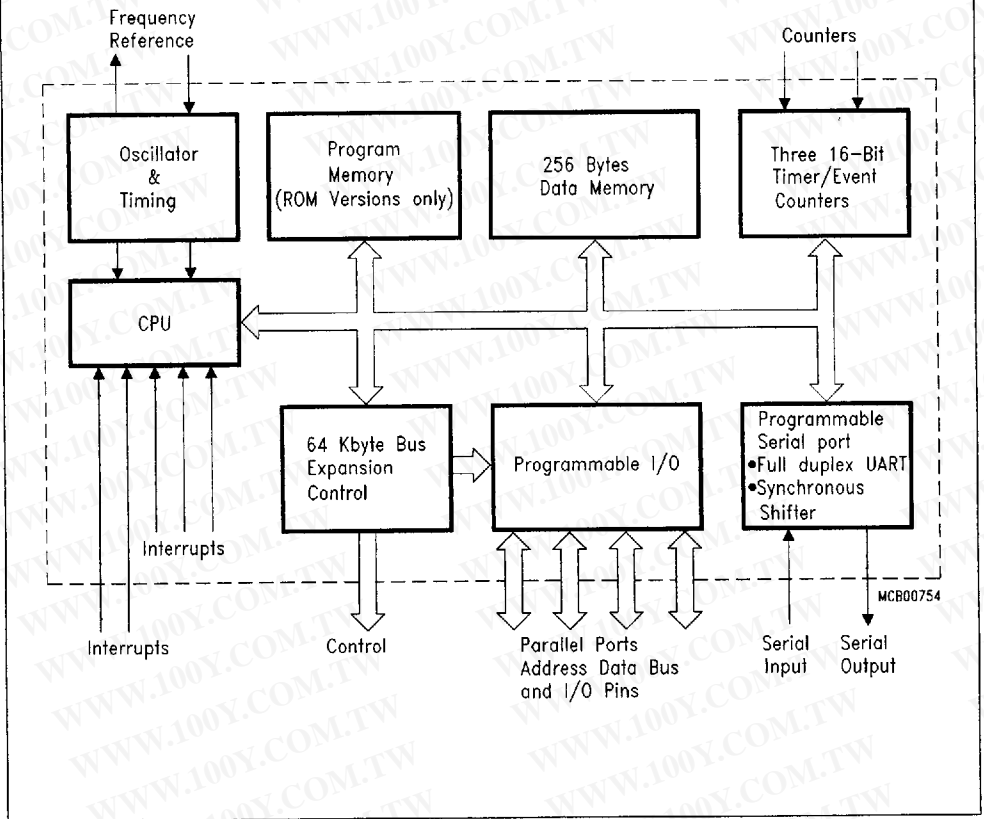

4

勝特力材料 886-3-5753170
 勝特力电子(上海) 86-21-54151736
 勝特力电子(深圳) 86-755-83298787
[Http://www.100y.com.tw](http://www.100y.com.tw)

Absolute Maximum Ratings

Ambient temperature under bias
 SAB 8052B/8032B 0 to +70 °C
 Storage temperature..... - 65 to + 150 °C
 Voltage on any pin with respect to ground (V_{SS}) - 0.5 to + 7 V
 Power dissipation 2 W

Note: Stresses above those listed under "Absolute Maximum Ratings" may cause permanent damage to the device. This is a stress rating only and functional operation of the device at these or any other conditions above those indicated in the operational sections of this specification is not implied. Exposure to absolute maximum rating conditions for extended periods may affect device reliability.

DC Characteristics

$V_{CC} = 5 V \pm 10\%$; $V_{SS} = 0 V$
 $T_A = 0$ to +70 °C for SAB 8052B/8032B

Symbol	Parameter	Limit Values		Unit	Test Conditions
		min.	max.		
V_{IL}	Input low voltage	- 0.5	0.8	V	-
V_{IH}	Input high voltage (except RST/ V_{PD} and XTAL 2)	2.0	$V_{CC} + 0.5$	V	-
V_{IH1}	Input high voltage to RST/ V_{PD} for reset, XTAL 2	2.5	$V_{CC} + 0.5$	V	XTAL1 to V_{SS}
V_{PD}	Power down voltage to RST/ V_{PD}	4.5	5.5	V	$V_{CC} = 0 V$
V_{OL}	Output low voltage Ports 1, 2, 3	-	0.45	V	$I_{OL} = 1.6 mA$
V_{OL1}	Output low voltage Port 0, ALE, PSEN	-	0.45	V	$I_{OL} = 3.2 mA$
V_{OH}	Output high voltage Ports 1, 2, 3	2.4	-	V	$I_{OH} = - 80 \mu A$
V_{OH1}	Output high voltage Port 0, ALE, PSEN	2.4	-	V	$I_{OH} = - 400 \mu A$

勝特力材料 886-3-5753170
 勝特力电子(上海) 86-21-54151736
 勝特力电子(深圳) 86-755-83298787
[Http://www.100y.com.tw](http://www.100y.com.tw)

DC Characteristics (cont'd)

Symbol	Parameter	Limit Values		Unit	Test Conditions
		min.	max.		
I_{IL}	Logical 0 input current Ports 1, 2, 3	–	– 500	μA	$V_{IL} = 0.45 \text{ V}$
I_{IL2}	Logical 0 input current XTAL 2 SAB 8052B/8032B - 12/16/20	–	– 3.2	mA	XTAL1 = V_{SS} $V_{IL} = 0.45 \text{ V}$
I_{IH1}	Input high current to RST/ V_{PD} for reset	–	500	μA	$V_{IN} = V_{CC} - 1.5 \text{ V}$
I_{LI}	Input leakage current to port 0, EA	–	± 10	μA	$0 \text{ V} < V_{IN} < V_{CC}$
I_{CC}	Power supply current SAB 8052B/8032B SAB 8052B-16/8032B-16 SAB 8052B-20/8032B-20	– – –	175 175 175	mA mA mA	All outputs disconnected
I_{PD}	Power down current	–	15	mA	$V_{CC} = 0 \text{ V};$ $V_{PD} = 4.5 \dots 5.5 \text{ V}$
C_{IO}	Capacitance of I/O buffer	–	10	pF	$f_c = 1 \text{ MHz}$

4

勝特力材料 886-3-5753170
 勝特力电子(上海) 86-21-54151736
 勝特力电子(深圳) 86-755-83298787
[Http://www.100y.com.tw](http://www.100y.com.tw)

SAB 8052/8032 Family

AC Characteristics for SAB 8052B/8032B, 12 MHz

$V_{CC} = 5\text{ V} \pm 10\%$; $V_{SS} = 0\text{ V}$

(C_L for port 0, ALE and $\overline{\text{PSEN}}$ outputs = 100 pF; C_L for all other outputs = 80 pF)

$T_A = 0$ to $+70\text{ }^\circ\text{C}$ for SAB 8052B/8032B

Please refer to AC characteristics for SAB 8051A/8031A, 12MHz

AC Characteristics for SAB 8052B/8032B, 16 MHz

$V_{CC} = 5\text{ V} \pm 10\%$; $V_{SS} = 0\text{ V}$

(C_L for port 0, ALE and $\overline{\text{PSEN}}$ outputs = 100 pF; C_L for all other outputs = 80 pF)

$T_A = 0$ to $70\text{ }^\circ\text{C}$; for SAB 8052B/8032B-16

Please refer for AC characteristics to the SAB 8051A/8031A-16, 16MHz

勝特力材料 886-3-5753170

勝特力电子(上海) 86-21-54151736

勝特力电子(深圳) 86-755-83298787

[Http://www.100y.com.tw](http://www.100y.com.tw)

AC Characteristics for SAB 8032B-20, 20 MHz

 $T_A = 0 \text{ to } 70 \text{ }^\circ\text{C}$; $V_{CC} = 5 \text{ V} \pm 10\%$; $V_{SS} = 0 \text{ V}$
 $(C_L \text{ for port 0, ALE and PSEN outputs} = 100 \text{ pF}; C_L \text{ for all other outputs} = 80 \text{ pF})$

Symbol	Parameter	Limit Values				Unit
		Clock 20 MHz clock		Variable clock $1/t_{CLCL} = 1.2 \text{ MHz to } 20 \text{ MHz}$		
		min.	max.	min.	max.	

Program Memory Characteristics

t_{UHLL}	ALE pulse width	60	–	$2t_{aCL}-40$	–	ns
t_{AVLL}	Address setup to ALE	20	–	$t_{aCL}-30$	–	ns
t_{LAX1}	Address hold after ALE	20	–	$t_{aCL}-30$	–	ns
t_{LLIV}	ALE to valid instruction in	–	100	–	$4t_{aCL}-100$	ns
t_{LLPL}	ALE to PSEN	25	–	$t_{aCL}-25$	–	ns
t_{FLPH}	PSEN pulse width	115	–	$3t_{aCL}-35$	–	ns
t_{PLIV}	PSEN to valid instruction in	–	75	–	$3t_{aCL}-75$	ns
t_{PXIX}	Input instruction hold after PSEN	0	–	0	–	ns
$t_{PXIZ}^*)$	Input instruction float after PSEN	–	40	–	$t_{aCL}-10$	ns
$t_{PXAV}^*)$	Address valid after PSEN	47	–	$t_{aCL}-3$	–	ns
t_{AVIV}	Address to valid instruction in	–	190	–	$5t_{aCL}-60$	ns
t_{AZPL}	Address float to PSEN	0	–	0	–	ns

*) Interfacing the SAB 8032B-20 to devices with float times up to 45 ns is permissible. This limited bus contention will not cause any damage to port 0 drivers.

勝特力材料 886-3-5753170
 勝特力电子(上海) 86-21-54151736
 勝特力电子(深圳) 86-755-83298787
[Http://www.100y.com.tw](http://www.100y.com.tw)

AC Characteristics for SAB 8032B-20, 20 MHz (cont'd)

Symbol	Parameter	Limit Values				Unit
		Clock 20 MHz clock		Variable clock 1/ <i>t</i> _{CLCL} = 1.2 MHz to 20 MHz		
		min.	max.	min.	max.	

External Data Memory Characteristics

<i>t</i> _{RLRH}	\overline{RD} pulse width	200	–	6 <i>t</i> _{CLCL} – 100	–	ns
<i>t</i> _{WLWH}	\overline{WR} pulse width	200	–	6 <i>t</i> _{CLCL} – 100	–	ns
<i>t</i> _{LAX2}	Address hold after ALE	70	–	2 <i>t</i> _{CLCL} – 30	–	ns
<i>t</i> _{RLDV}	\overline{RD} to valid data in	–	100	–	5 <i>t</i> _{CLCL} – 150	ns
<i>t</i> _{RHDX}	Data hold after \overline{RD}	0	–	0	–	ns
<i>t</i> _{RHDZ}	Data float after \overline{RD}	–	40	–	2 <i>t</i> _{CLCL} – 60	ns
<i>t</i> _{LLDV}	ALE to valid data in	–	250	–	8 <i>t</i> _{CLCL} – 150	ns
<i>t</i> _{AVDV}	Address to valid data in	–	285	–	9 <i>t</i> _{CLCL} – 165	ns
<i>t</i> _{LLWL}	ALE to \overline{WR} or \overline{RD}	100	200	3 <i>t</i> _{CLCL} – 50	3 <i>t</i> _{CLCL} + 50	ns
<i>t</i> _{AVWL}	Address to \overline{WR} or \overline{RD}	70	–	4 <i>t</i> _{CLCL} – 130	–	ns
<i>t</i> _{WHLH}	\overline{WR} or \overline{RD} high to ALE high	20	80	<i>t</i> _{CLCL} – 30	<i>t</i> _{CLCL} + 30	ns
<i>t</i> _{QVWX}	Data valid to \overline{WR} transition	5	–	<i>t</i> _{CLCL} – 45	–	ns
<i>t</i> _{QVWH}	Data setup before \overline{WR}	200	–	7 <i>t</i> _{CLCL} – 150	–	ns
<i>t</i> _{WHQX}	Data hold after \overline{WR}	10	–	<i>t</i> _{CLCL} – 40	–	ns
<i>t</i> _{RLAZ}	Address float after \overline{RD}	–	0	–	0	ns

External Clock Drive XTAL2

<i>t</i> _{CLCL}	Oscillator period	–	–	50	833.3	ns
<i>t</i> _{CHCX}	High time	–	–	15	<i>t</i> _{CLCL} – <i>t</i> _{CLCX}	ns
<i>t</i> _{CLCX}	Low time	–	–	15	<i>t</i> _{CLCL} – <i>t</i> _{CHCX}	ns
<i>t</i> _{CLCH}	Rise time	–	–	–	15	ns
<i>t</i> _{CHCL}	Fall time	–	–	–	15	ns

勝特力材料 886-3-5753170
 勝特力电子(上海) 86-21-54151736
 勝特力电子(深圳) 86-755-83298787
[Http://www.100y.com.tw](http://www.100y.com.tw)

ROM Verification Characteristics for SAB 8052B/8032B Family

$T_A = 25^\circ\text{C} \pm 5^\circ\text{C}$; $V_{CC} = 5\text{V} \pm 10\%$; $V_{SS} = 0\text{V}$

Symbol	Parameter	Limit Values		Unit
		min.	max.	
t_{AVQV}	Address to valid data	–	48 $t_{a,CL}$	ns
t_{ELQV}	ENABLE to valid data	–	48 $t_{a,CL}$	ns
t_{EHQZ}	Data float after ENABLE	0	48 $t_{a,CL}$	ns
$1/t_{a,CL}$	Oscillator frequency	4	6	MHz

Figure 16
ROM Verification

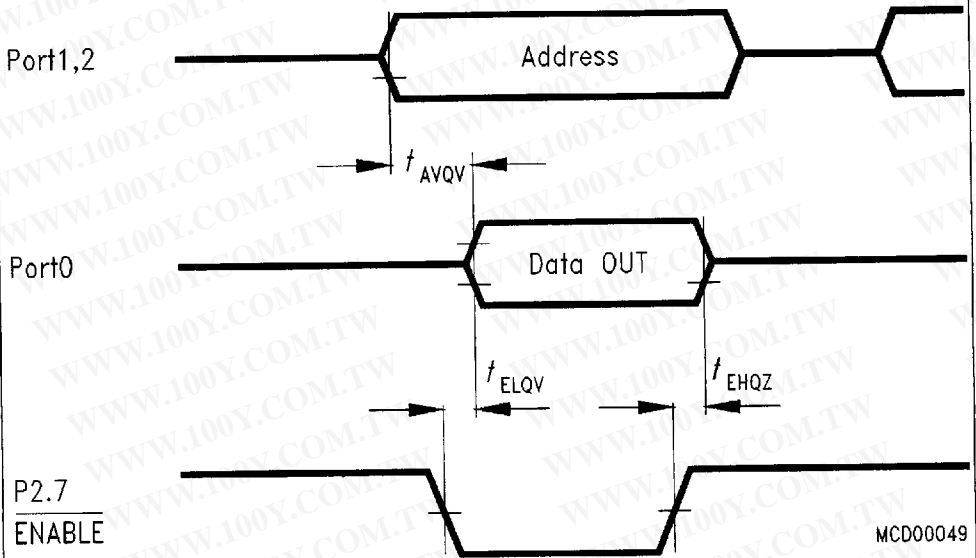

Microcontroller	Address	Data	Inputs
SAB 8052B 8K x 8	P1.0 – P1.7 = A0 – A7 P2.0 – P2.4 = A8 – A12	Port 0 = D0 – D7	P2.5 – P2.6, PSEN = V_{SS} ALE, EA = V_{IH} RST/VPD = V_{IH1}

勝特力材料 886-3-5753170
 勝特力电子(上海) 86-21-54151736
 勝特力电子(深圳) 86-755-83298787
[Http://www.100y.com.tw](http://www.100y.com.tw)

Waveforms

Please refer to SAB 8051A/8031A for AC waveforms.

Package Outlines

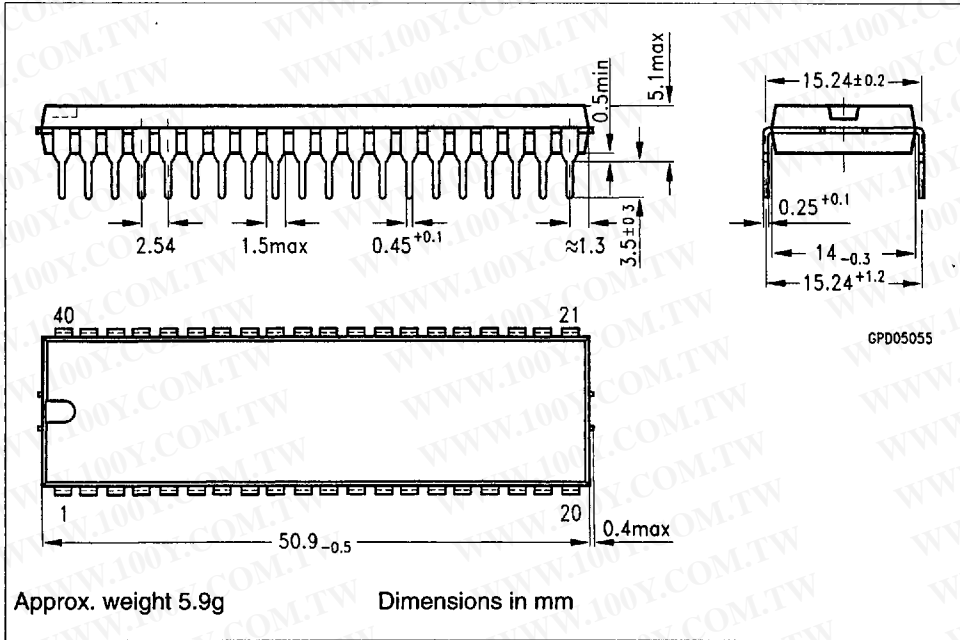

Plastic Package, P-DIP-40

(Dual-In-Line Package)

20 B 40 DIN 41870 T10

勝特力材料 886-3-5753170
勝特力电子(上海) 86-21-54151736
勝特力电子(深圳) 86-755-83298787
[Http://www.100y.com.tw](http://www.100y.com.tw)

Package Outlines

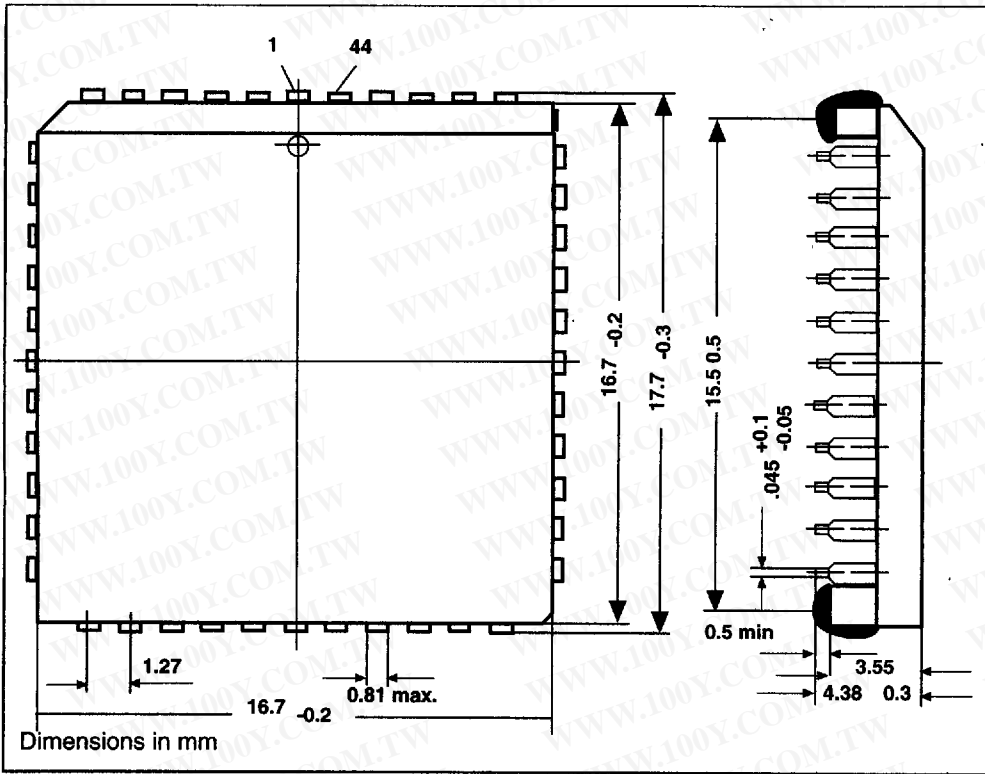

Plastic Package, P-LCC-44
(Plastic Leaded—Chip Carrier) -SMD

勝特力材料 886-3-5753170
勝特力电子(上海) 86-21-54151736
勝特力电子(深圳) 86-755-83298787
[Http://www.100y.com.tw](http://www.100y.com.tw)

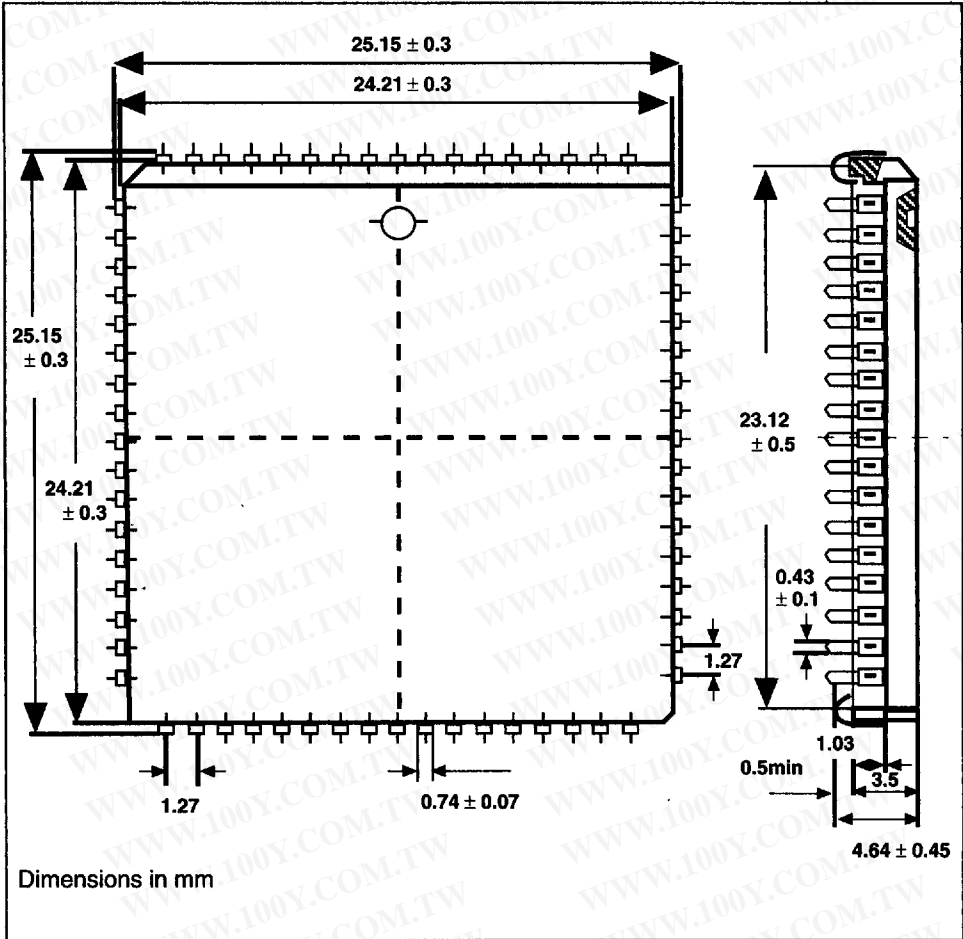

9

Plastic Package, PLCC-68 (SMD)
(plastic leaded chip carrier)

勝特力材料 886-3-5753170
 勝特力电子(上海) 86-21-54151736
 勝特力电子(深圳) 86-755-83298787
[Http://www.100y.com.tw](http://www.100y.com.tw)

Package Outlines

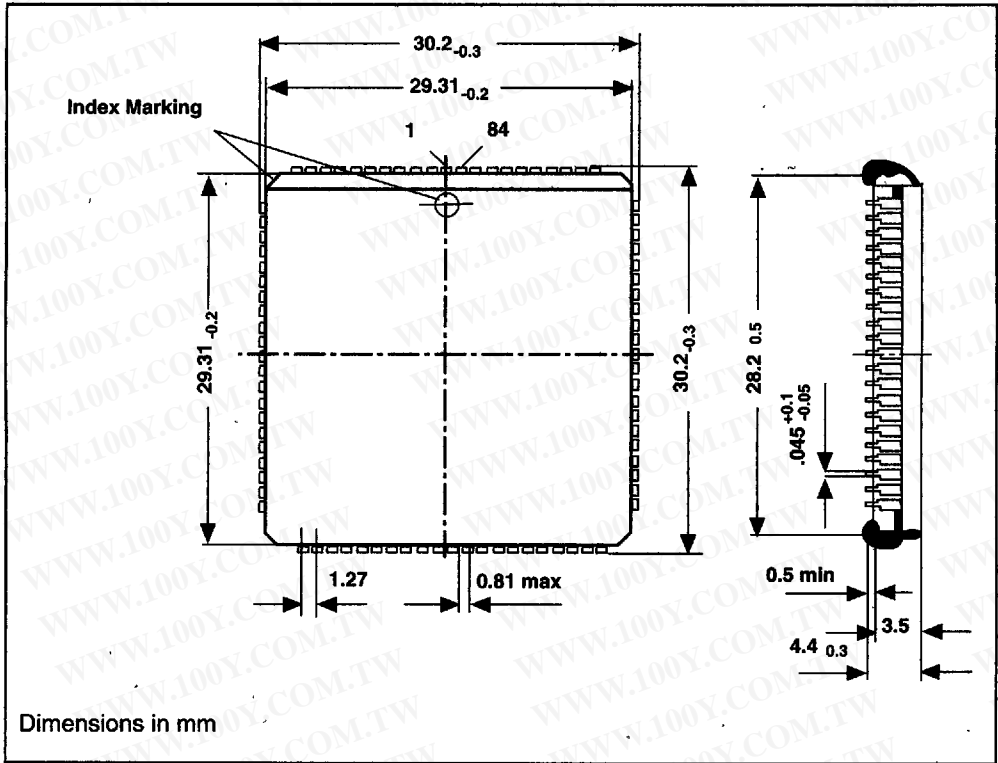

Plastic Package, PLCC-84 (SMD)
(plastic leaded chip carrier)

勝特力材料 886-3-5753170
勝特力电子(上海) 86-21-54151736
勝特力电子(深圳) 86-755-83298787
[Http://www.100y.com.tw](http://www.100y.com.tw)

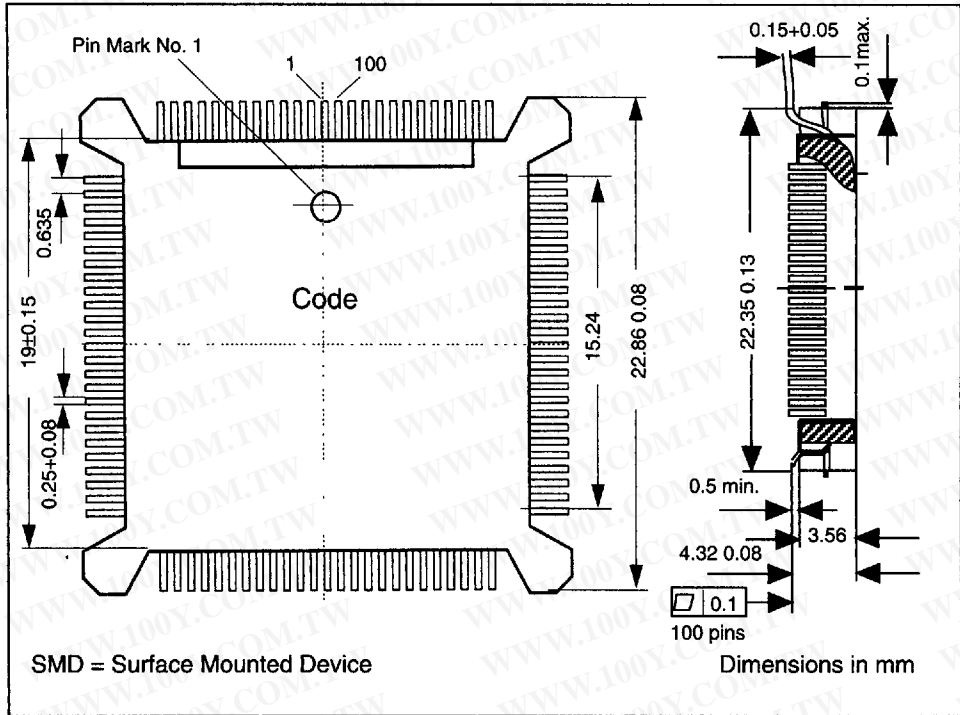

9

Plastic Package, P-QFP-100
 (Plastic Quad-Flat-Pack) - SMD

勝特力材料 886-3-5753170
 勝特力电子(上海) 86-21-54151736
 勝特力电子(深圳) 86-755-83298787
[Http://www.100y.com.tw](http://www.100y.com.tw)