



LM124-LM224-LM324

Low Power Quad Operational Amplifiers

- Wide gain bandwidth: 1.3MHz
- Input common-mode voltage range includes ground
- Large voltage gain: 100dB
- Very low supply current/ampli: 375 μ A
- Low input bias current: 20nA
- Low input offset voltage: 5mV max.
(for more accurate applications, use the equivalent parts LM124A-LM224A-LM324A which feature 3mV max.)
- Low input offset current: 2nA
- Wide power supply range:
Single supply: +3V to +30V
Dual supplies: \pm 1.5V to \pm 15V

Description

These circuits consist of four independent, high gain, internally frequency compensated operational amplifiers. They operate from a single power supply over a wide range of voltages.

Operation from split power supplies is also possible and the low power supply current drain is independent of the magnitude of the power supply voltage.

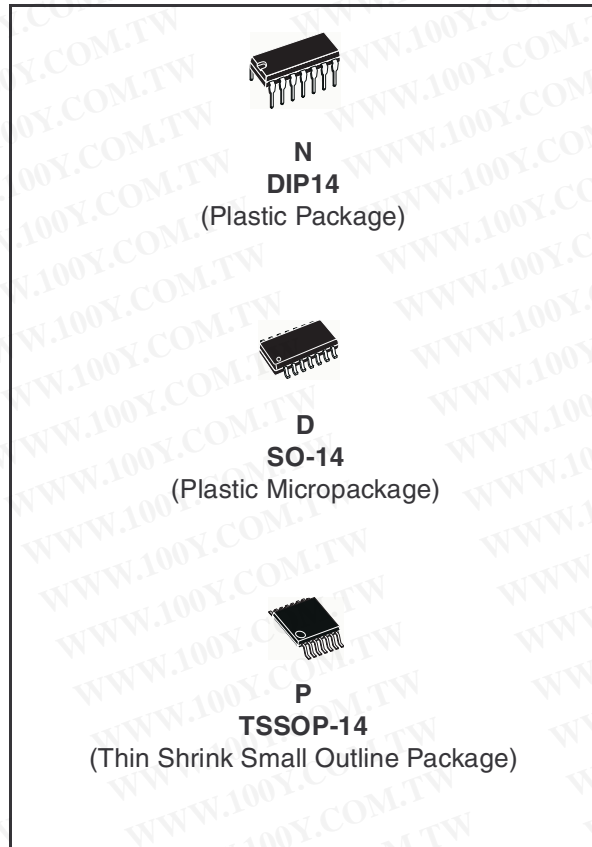

Order Codes

Part Number	Temperature Range	Package	Packaging
LM124N	-55°C, +125°C	DIP	Tube
LM124D/DT		SO	Tube or Tape & Reel
LM224N	-40°C, +105°C	DIP	Tube
LM224D/DT		SO	Tube or Tape & Reel
LM224PT		TSSOP (Thin Shrink Outline Package)	Tape & Reel
LM324N	0°C, +70°C	DIP	Tube
LM324D/DT		SO	Tube or Tape & Reel
LM324PT		TSSOP (Thin Shrink Outline Package)	Tape & Reel

1 Absolute Maximum Ratings

Table 1. 15Key parameters and their absolute maximum ratings

Symbol	Parameter	LM124	LM224	LM324	Unit
V _{CC}	Supply voltage	±16 or 32			V
V _i	Input Voltage	-0.3 to V _{CC} + 0.3			V
V _{id}	Differential Input Voltage (1)	-0.3 to V _{CC} + 0.3			V
P _{tot}	Power Dissipation N Suffix	500	500	500	mW
	D Suffix		400	400	
	Output Short-circuit Duration (2)	Infinite			
I _{in}	Input Current (3)	50	50	50	mA
T _{oper}	Operating Free-air Temperature Range	-55 to +125	-40 to +105	0 to +70	°C
T _{stg}	Storage Temperature Range	-65 to +150			°C
R _{thja}	Thermal Resistance Junction to Ambient SO14	103			°C/W
	TSSOP14	100			
	DIP14	66			
ESD	HBM: Human Body Model(4)	250			V
	MM: Machine Model(5)	150			
	CDM: Charged Device Model	1500			

1. Either or both input voltages must not exceed the magnitude of V_{CC}⁺ or V_{CC}⁻.
2. Short-circuits from the output to V_{CC} can cause excessive heating if V_{CC} > 15V. The maximum output current is approximately 40mA independent of the magnitude of V_{CC}. Destructive dissipation can result from simultaneous short-circuit on all amplifiers.
3. This input current only exists when the voltage at any of the input leads is driven negative. It is due to the collector-base junction of the input PNP transistor becoming forward biased and thereby acting as input diodes clamps. In addition to this diode action, there is also NPN parasitic action on the IC chip. this transistor action can cause the output voltages of the op-amps to go to the V_{CC} voltage level (or to ground for a large overdrive) for the time duration than an input is driven negative. This is not destructive and normal output will set up again for input voltage higher than -0.3V.
4. Human body model, 100pF discharged through a 1.5kΩ resistor into pin of device.
5. Machine model ESD, a 200pF cap is charged to the specified voltage, then discharged directly into the IC with no external series resistor (internal resistor < 5Ω), into pin to pin of device.

勝特力材料 886-3-5753170
胜特力电子(上海) 86-21-54151736
胜特力电子(深圳) 86-755-83298787
[Http://www.100y.com.tw](http://www.100y.com.tw)

2 Pin & Schematic Diagram

Figure 1. Pin connections (top view)

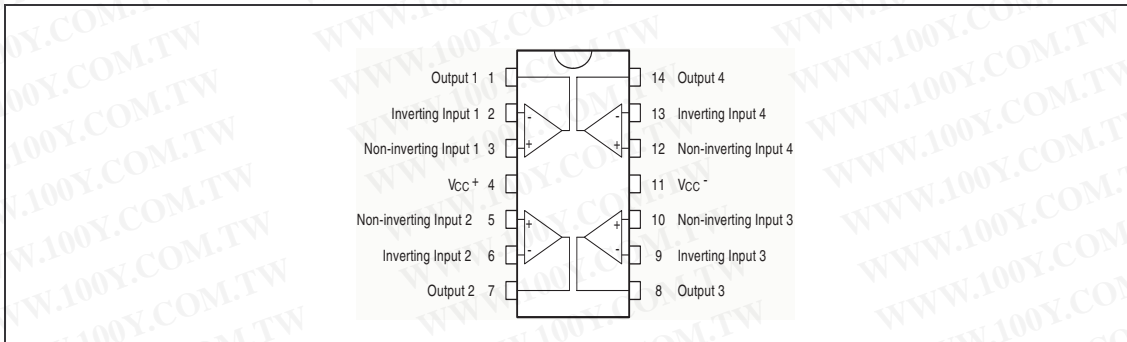
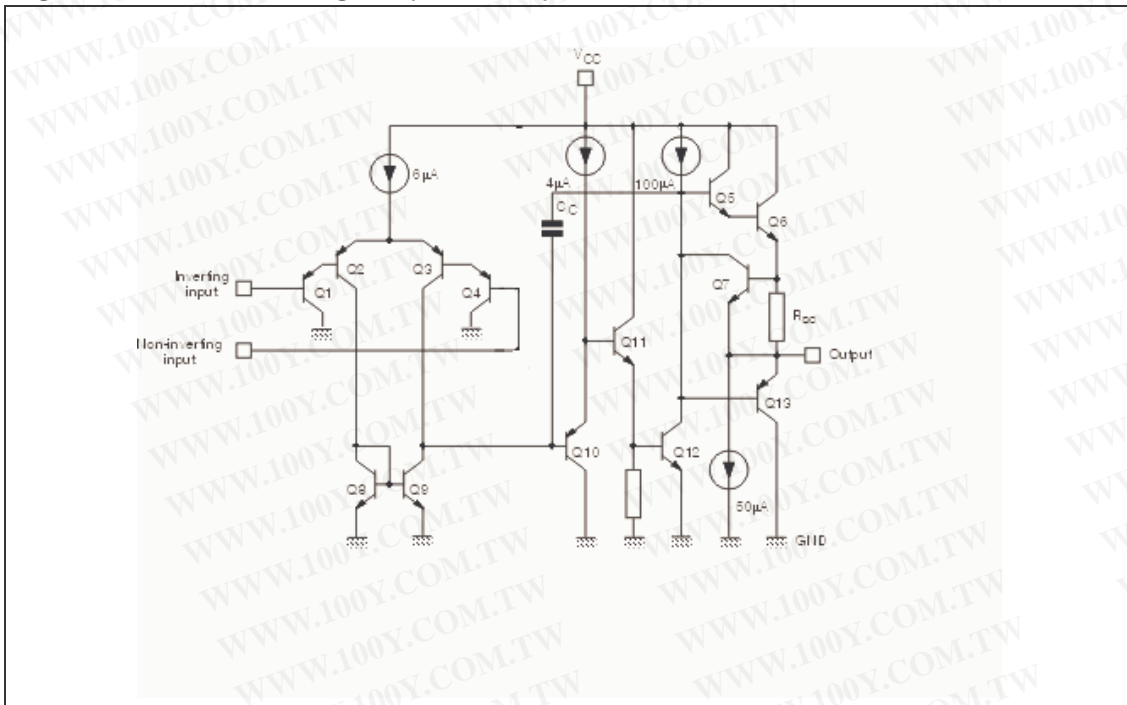

Figure 2. Schematic diagram (1/4 LM124)



勝特力材料 886-3-5753170
 勝特力电子(上海) 86-21-54151736
 勝特力电子(深圳) 86-755-83298787
[Http://www.100y.com.tw](http://www.100y.com.tw)

3 Electrical Characteristics

Table 2. $V_{CC}^+ = +5V$, $V_{CC}^- = \text{Ground}$, $V_o = 1.4V$, $T_{amb} = +25^\circ C$ (unless otherwise specified)

Symbol	Parameter	Min.	Typ.	Max.	Unit
V_{io}	Input Offset Voltage - note (1) $T_{amb} = +25^\circ C$ LM324		2	5 7	mV
	$T_{min} \leq T_{amb} \leq T_{max}$ LM324			7 9	
I_{io}	Input Offset Current $T_{amb} = +25^\circ C$ $T_{min} \leq T_{amb} \leq T_{max}$		2	30 100	nA
I_{ib}	Input Bias Current - note (2) $T_{amb} = +25^\circ C$ $T_{min} \leq T_{amb} \leq T_{max}$		20	150 300	nA
A_{vd}	Large Signal Voltage Gain $V_{CC}^+ = +15V$, $R_L = 2k\Omega$, $V_o = 1.4V$ to $11.4V$ $T_{amb} = +25^\circ C$ $T_{min} \leq T_{amb} \leq T_{max}$	50 25	100		V/mV
SVR	Supply Voltage Rejection Ratio ($R_s \leq 10k\Omega$) $V_{CC}^+ = 5V$ to $30V$ $T_{amb} = +25^\circ C$ $T_{min} \leq T_{amb} \leq T_{max}$	65 65	110		dB
I_{CC}	Supply Current, all Amp, no load $T_{amb} = +25^\circ C$ $V_{CC} = +5V$ $V_{CC} = +30V$ $T_{min} \leq T_{amb} \leq T_{max}$ $V_{CC} = +5V$ $V_{CC} = +30V$		0.7 1.5 0.8 1.5	1.2 3 1.2 3	mA
V_{icm}	Input Common Mode Voltage Range $V_{CC} = +30V$ - note (3) $T_{amb} = +25^\circ C$ $T_{min} \leq T_{amb} \leq T_{max}$	0 0		$V_{CC} - 1.5$ $V_{CC} - 2$	V
CMR	Common Mode Rejection Ratio ($R_s \leq 10k\Omega$) $T_{amb} = +25^\circ C$ $T_{min} \leq T_{amb} \leq T_{max}$	70 60	80		dB
I_{source}	Output Current Source ($V_{id} = +1V$) $V_{CC} = +15V$, $V_o = +2V$	20	40	70	mA
I_{sink}	Output Sink Current ($V_{id} = -1V$) $V_{CC} = +15V$, $V_o = +2V$	10	20		mA μA
	$V_{CC} = +15V$, $V_o = +0.2V$	12	50		
V_{OH}	High Level Output Voltage $V_{CC} = +30V$ $T_{amb} = +25^\circ C$ $T_{min} \leq T_{amb} \leq T_{max}$ $R_L = 2k\Omega$	26 26	27		V
	$T_{amb} = +25^\circ C$ $T_{min} \leq T_{amb} \leq T_{max}$ $R_L = 10k\Omega$	27 27	28		
	$V_{CC} = +5V$, $R_L = 2k\Omega$ $T_{amb} = +25^\circ C$	3.5			
	$T_{min} \leq T_{amb} \leq T_{max}$	3			

Table 2. $V_{CC}^+ = +5V$, $V_{CC}^- = \text{Ground}$, $V_o = 1.4V$, $T_{amb} = +25^\circ\text{C}$ (unless otherwise specified)

Symbol	Parameter	Min.	Typ.	Max.	Unit
V_{OL}	Low Level Output Voltage ($R_L = 10k\Omega$) $T_{amb} = +25^\circ\text{C}$ $T_{min} \leq T_{amb} \leq T_{max}$		5	20 20	mV
SR	Slew Rate $V_{CC} = 15V$, $V_i = 0.5$ to $3V$, $R_L = 2k\Omega$, $C_L = 100pF$, unity Gain		0.4		V/ μs
GBP	Gain Bandwidth Product $V_{CC} = 30V$, $f = 100kHz$, $V_{in} = 10mV$, $R_L = 2k\Omega$, $C_L = 100pF$		1.3		MHz
THD	Total Harmonic Distortion $f = 1kHz$, $A_v = 20dB$, $R_L = 2k\Omega$, $V_o = 2V_{pp}$, $C_L = 100pF$, $V_{CC} = 30V$		0.015		%
e_n	Equivalent Input Noise Voltage $f = 1kHz$, $R_s = 100\Omega$, $V_{CC} = 30V$		40		$\frac{nV}{\sqrt{Hz}}$
DV_{io}	Input Offset Voltage Drift		7	30	$\mu\text{V}/^\circ\text{C}$
DI_{lio}	Input Offset Current Drift		10	200	$pA/^\circ\text{C}$
V_{o1}/V_{o2}	Channel Separation - note (4) $1kHz \leq f \leq 20kHz$		120		dB

- $V_o = 1.4V$, $R_s = 0\Omega$, $5V < V_{CC}^+ < 30V$, $0 < V_{ic} < V_{CC}^+ - 1.5V$
- The direction of the input current is out of the IC. This current is essentially constant, independent of the state of the output so no loading change exists on the input lines.
- The input common-mode voltage of either input signal voltage should not be allowed to go negative by more than $0.3V$. The upper end of the common-mode voltage range is $V_{CC}^+ - 1.5V$, but either or both inputs can go to $+32V$ without damage.
- Due to the proximity of external components insure that coupling is not originating via stray capacitance between these external parts. This typically can be detected as this type of capacitance increases at higher frequencies.

Table 3. $V_{CC}^+ = +15V$, $V_{CC}^- = 0V$, $T_{amb} = 25^\circ\text{C}$ (unless otherwise specified)

Symbol	Conditions	Value	Unit
V_{io}		0	mV
A_{vd}	$R_L = 2k\Omega$	100	V/mV
I_{cc}	No load, per amplifier	350	μA
V_{icm}		-15 to +13.5	V
V_{OH}	$R_L = 2k\Omega$ ($V_{CC}^+ = 15V$)	+13.5	V
V_{OL}	$R_L = 10k\Omega$	5	mV
I_{os}	$V_o = +2V$, $V_{CC} = +15V$	+40	mA
GBP	$R_L = 2k\Omega$, $C_L = 100pF$	1.3	MHz
SR	$R_L = 2k\Omega$, $C_L = 100pF$	0.4	V/ μs

勝特力材料 886-3-5753170
 勝特力电子(上海) 86-21-54151736
 勝特力电子(深圳) 86-755-83298787
[Http://www.100y.com.tw](http://www.100y.com.tw)

Figure 3. Input bias current vs. ambient temperature

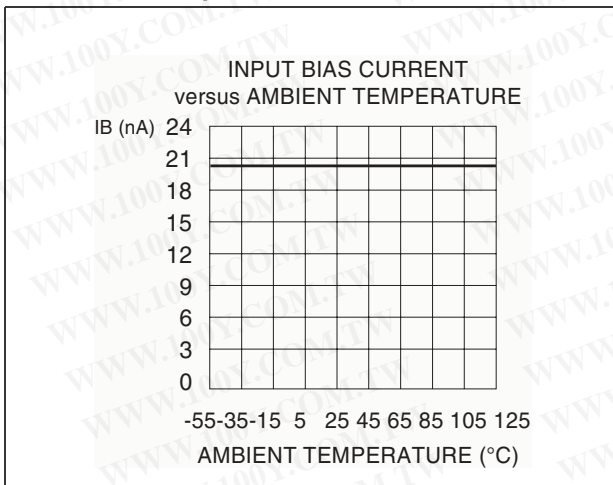

Figure 4. Current limiting

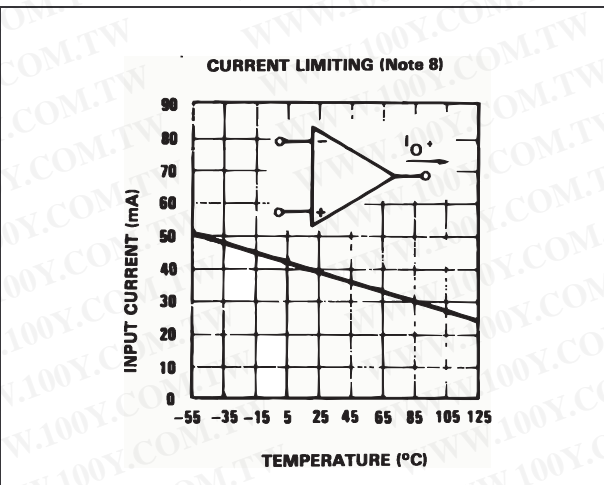

Figure 5. Input voltage range

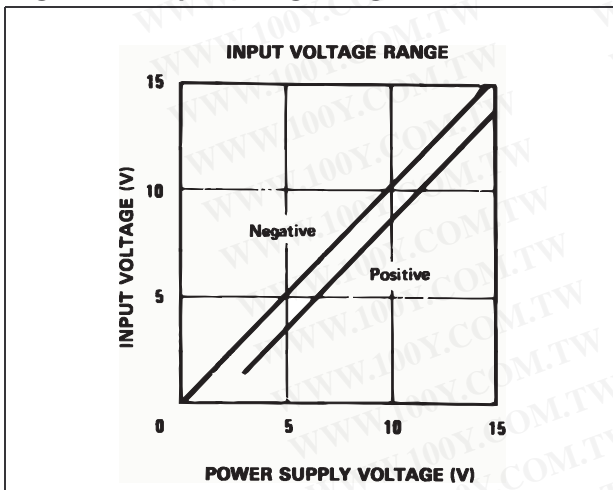

Figure 6. Supply current

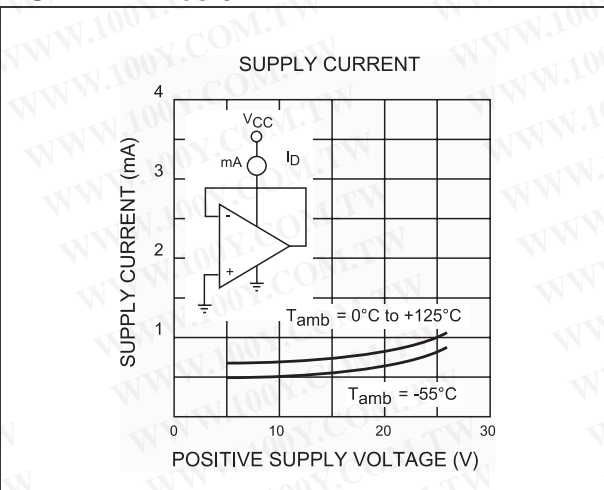

Figure 7. Gain bandwidth product

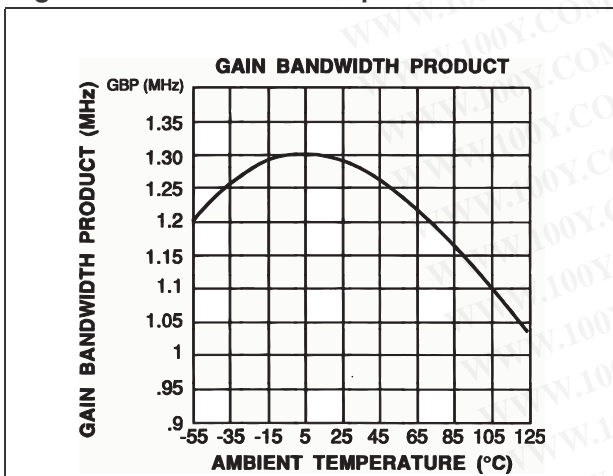

Figure 8. Common mode rejection ratio

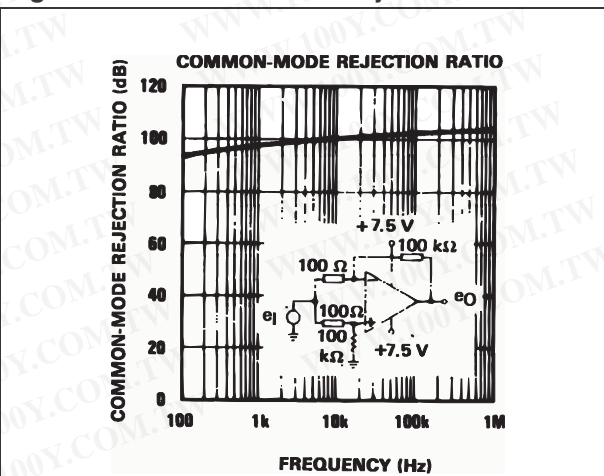
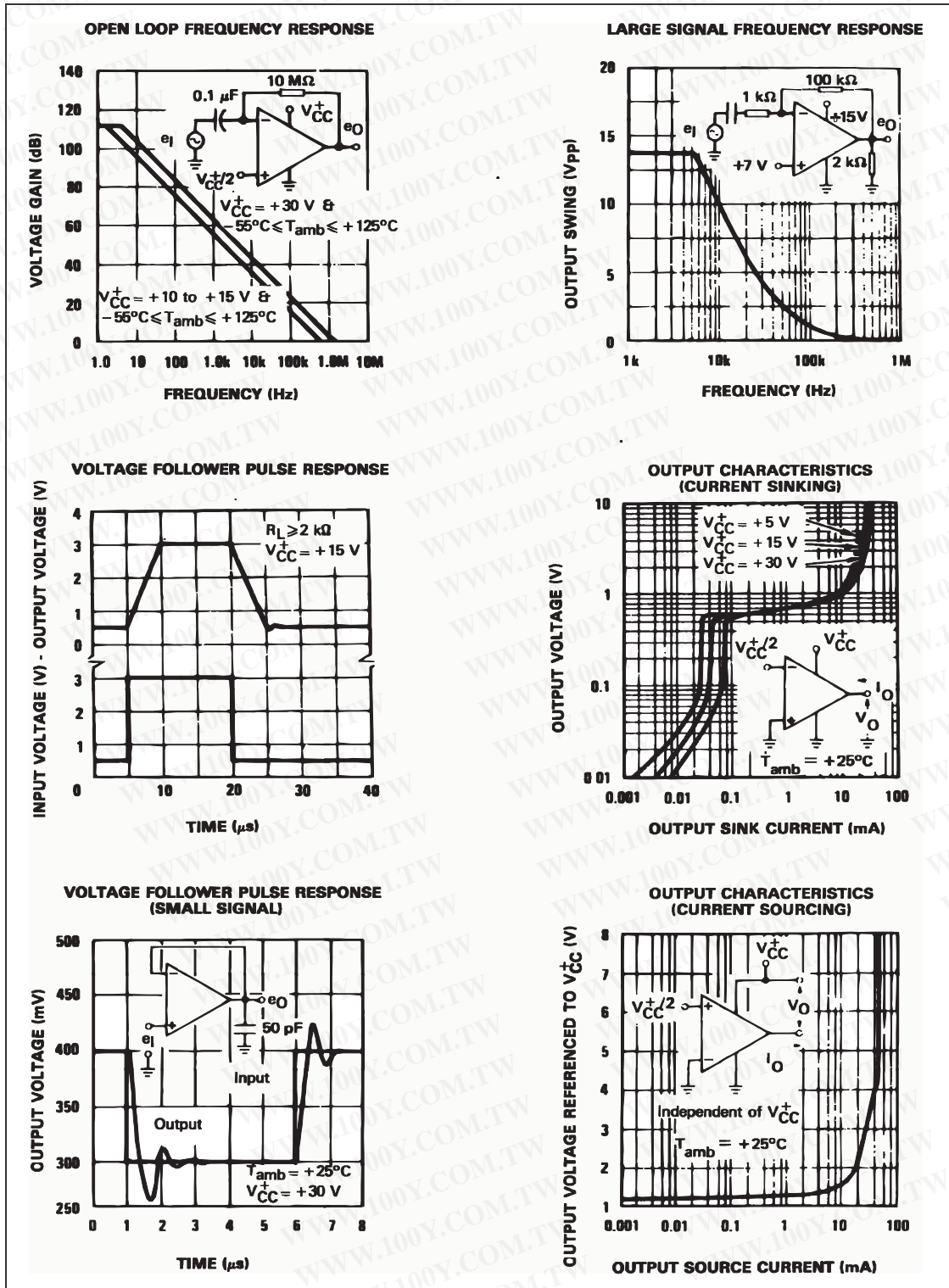

Figure 9. Electrical curves



勝特力材料 886-3-5753170
 勝特力电子(上海) 86-21-54151736
 勝特力电子(深圳) 86-755-83298787
[Http://www.100y.com.tw](http://www.100y.com.tw)

Figure 10. Input current

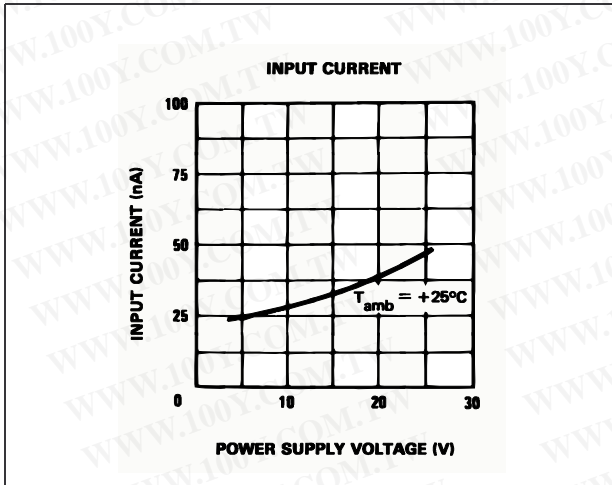

Figure 11. Large signal voltage gain

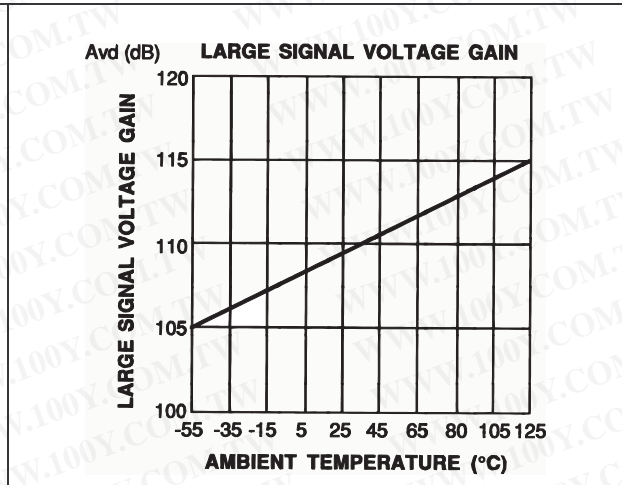

Figure 12. Power supply & common mode rejection ratio

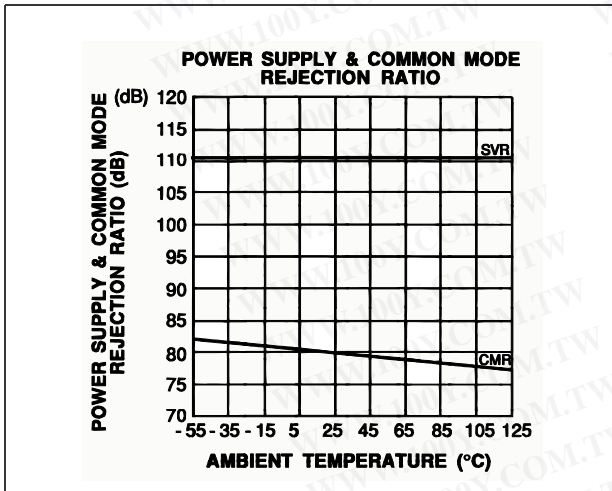
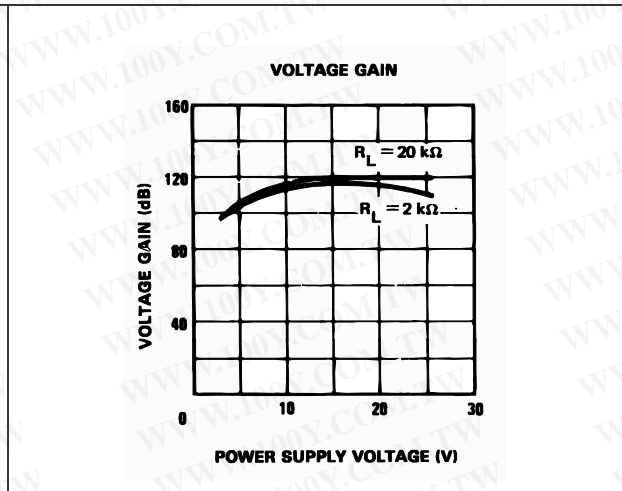

Figure 13. Voltage gain



勝特力材料 886-3-5753170
 勝特力电子(上海) 86-21-54151736
 勝特力电子(深圳) 86-755-83298787
[Http://www.100y.com.tw](http://www.100y.com.tw)

4 Typical Single - Supply Applications

Figure 14. AC coupled inverting amplifier

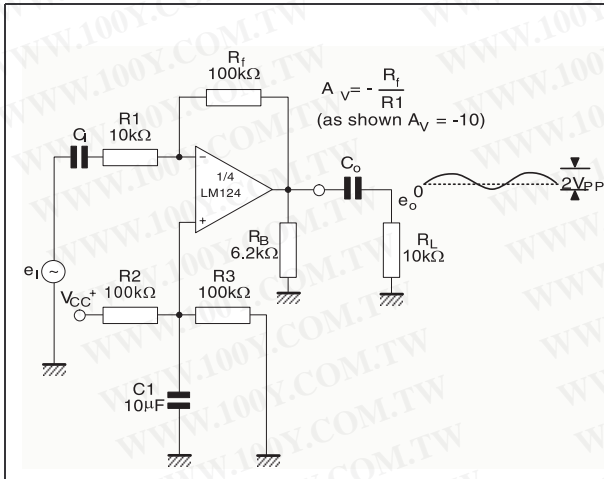

Figure 15. High input Z adjustable gain DC instrumentation amplifier

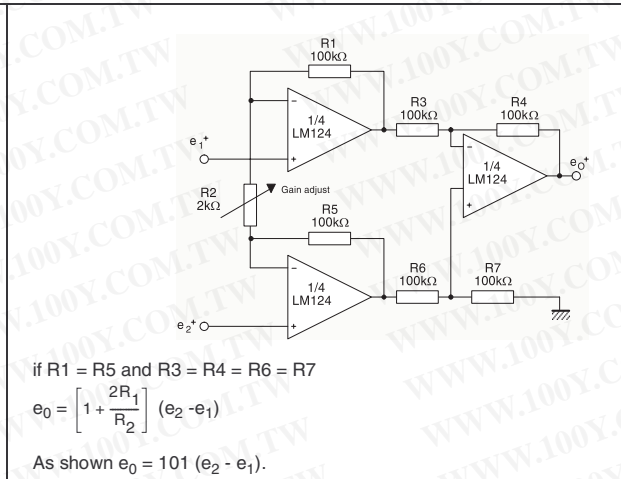

Figure 16. AC coupled non inverting amplifier

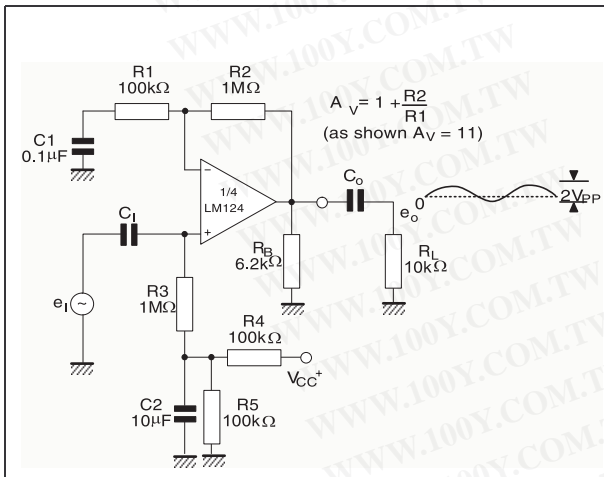

Figure 17. DC summing amplifier

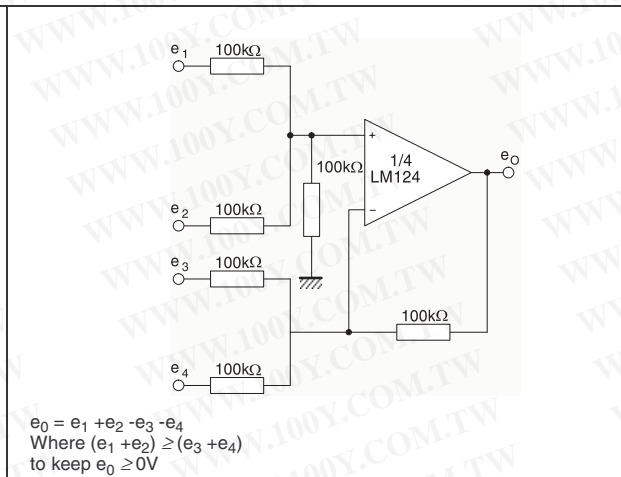

Figure 18. Non-inverting DC gain

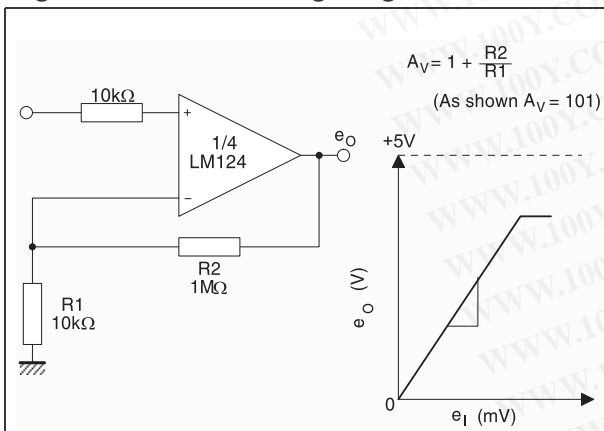

Figure 19. Low drift peak detector

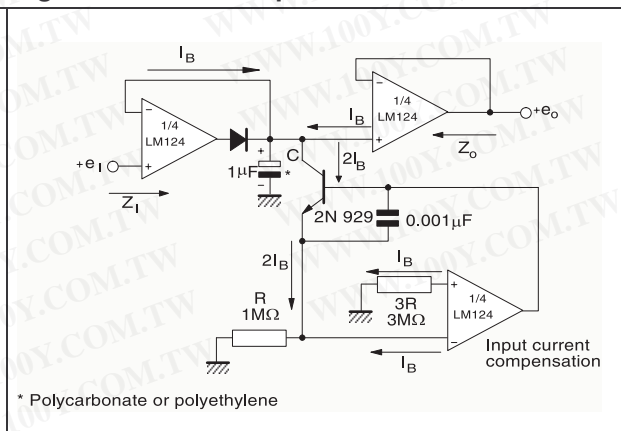

Figure 20. Activer bandpass filter

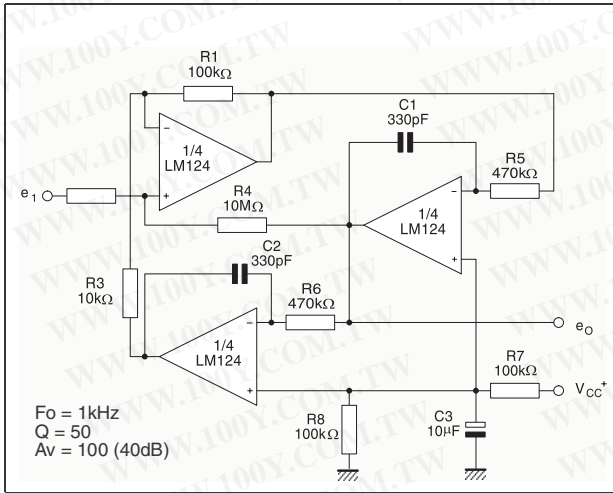

Figure 21. High input Z, DC differential amplifier

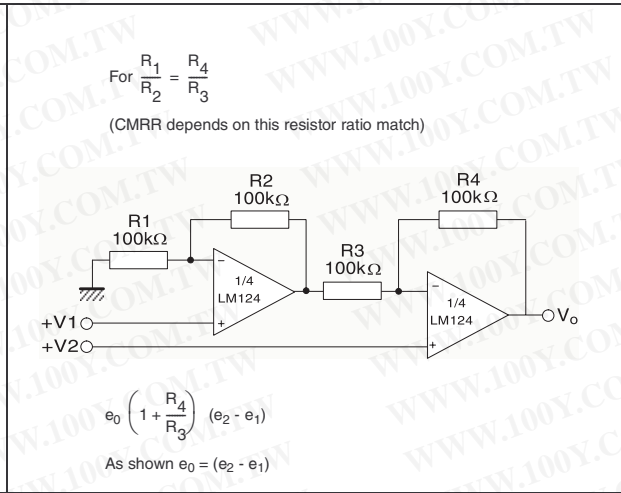
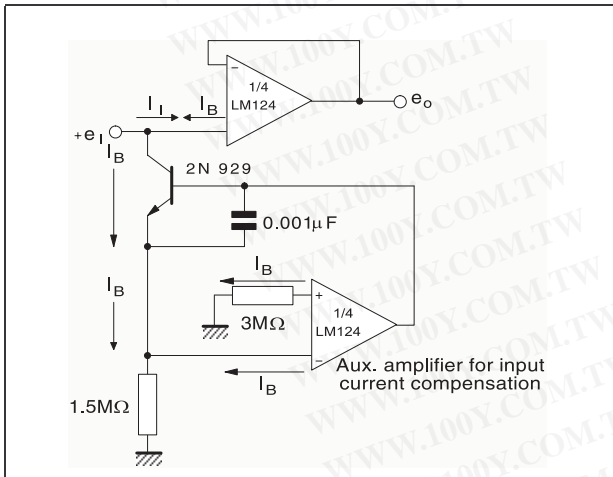

Figure 22. Using symmetrical amplifiers to reduce input current (general concept)



勝特力材料 86-3-5753170
 勝特力电子(上海) 86-21-54151736
 勝特力电子(深圳) 86-755-83298787
[Http://www.100y.com.tw](http://www.100y.com.tw)

5 Macromodels

Note: *Note: Please consider following remarks before using this macromodel:*

All models are a trade-off between accuracy and complexity (i.e. simulation time).

Macromodels are not a substitute to breadboarding; rather, they confirm the validity of a design approach and help to select surrounding component values.

A macromodel emulates the NOMINAL performance of a TYPICAL device within SPECIFIED OPERATING CONDITIONS (i.e. temperature, supply voltage, etc.). Thus the macromodel is often not as exhaustive as the datasheet, its goal is to illustrate the main parameters of the product.

Data issued from macromodels used outside of its specified conditions (Vcc, Temperature, etc.) or even worse: outside of the device operating conditions (Vcc, Vicm, etc.) are not reliable in any way.

** Standard Linear Ics Macromodels, 1993.

** CONNECTIONS :

- * 1 INVERTING INPUT
- * 2 NON-INVERTING INPUT
- * 3 OUTPUT
- * 4 POSITIVE POWER SUPPLY
- * 5 NEGATIVE POWER SUPPLY

.SUBCKT LM124 1 3 2 4 5 (analog)

.MODEL MDTH D IS=1E-8 KF=3.104131E-15 CJO=10F

* INPUT STAGE

CIP 2 5 1.000000E-12
 CIN 1 5 1.000000E-12
 EIP 10 5 2 5 1
 EIN 16 5 1 5 1
 RIP 10 11 2.600000E+01
 RIN 15 16 2.600000E+01
 RIS 11 15 2.003862E+02
 DIP 11 12 MDTH 400E-12
 DIN 15 14 MDTH 400E-12
 VAFP 12 13 DC 0
 VAFN 13 14 DC 0
 IPOL 13 5 1.000000E-05
 CPS 11 15 3.783376E-09
 DINN 17 13 MDTH 400E-12
 VIN 17 5 0.000000E+00
 DINR 15 18 MDTH 400E-12
 VIP 4 18 2.000000E+00
 FCP 4 5 VAFP 3.400000E+01
 FCN 5 4 VAFN 3.400000E+01
 FIBP 2 5 VAFN 2.000000E-03
 FIBN 5 1 VAFP 2.000000E-03
 * AMPLIFYING STAGE
 FIP 5 19 VAFP 3.600000E+02

勝特力材料 886-3-5753170
勝特力电子(上海) 86-21-54151736
勝特力电子(深圳) 86-755-83298787
Http://www.100y.com.tw

FIN 5 19 VOFN 3.600000E+02
RG1 19 5 3.652997E+06
RG2 19 4 3.652997E+06
CC 19 5 6.000000E-09
DOPM 19 22 MDTH 400E-12
DONM 21 19 MDTH 400E-12
HOPM 22 28 VOUT 7.500000E+03
VIPM 28 4 1.500000E+02
HONM 21 27 VOUT 7.500000E+03
VINM 5 27 1.500000E+02
EOUT 26 23 19 5 1
VOUT 23 5 0
ROUT 26 3 20
COUT 3 5 1.000000E-12
DOP 19 25 MDTH 400E-12
VOP 4 25 2.242230E+00
DON 24 19 MDTH 400E-12
VON 24 5 7.922301E-01
.ENDS

勝特力材料 886-3-5753170
勝特力电子(上海) 86-21-54151736
勝特力电子(深圳) 86-755-83298787
[Http://www.100y.com.tw](http://www.100y.com.tw)



6 Package Mechanical Data

In order to meet environmental requirements, ST offers these devices in ECOPACK® packages. These packages have a Lead-free second level interconnect. The category of second level interconnect is marked on the package and on the inner box label, in compliance with JEDEC Standard JESD97. The maximum ratings related to soldering conditions are also marked on the inner box label. ECOPACK is an ST trademark. ECOPACK specifications are available at: www.st.com.

6.1 DIP14 Package

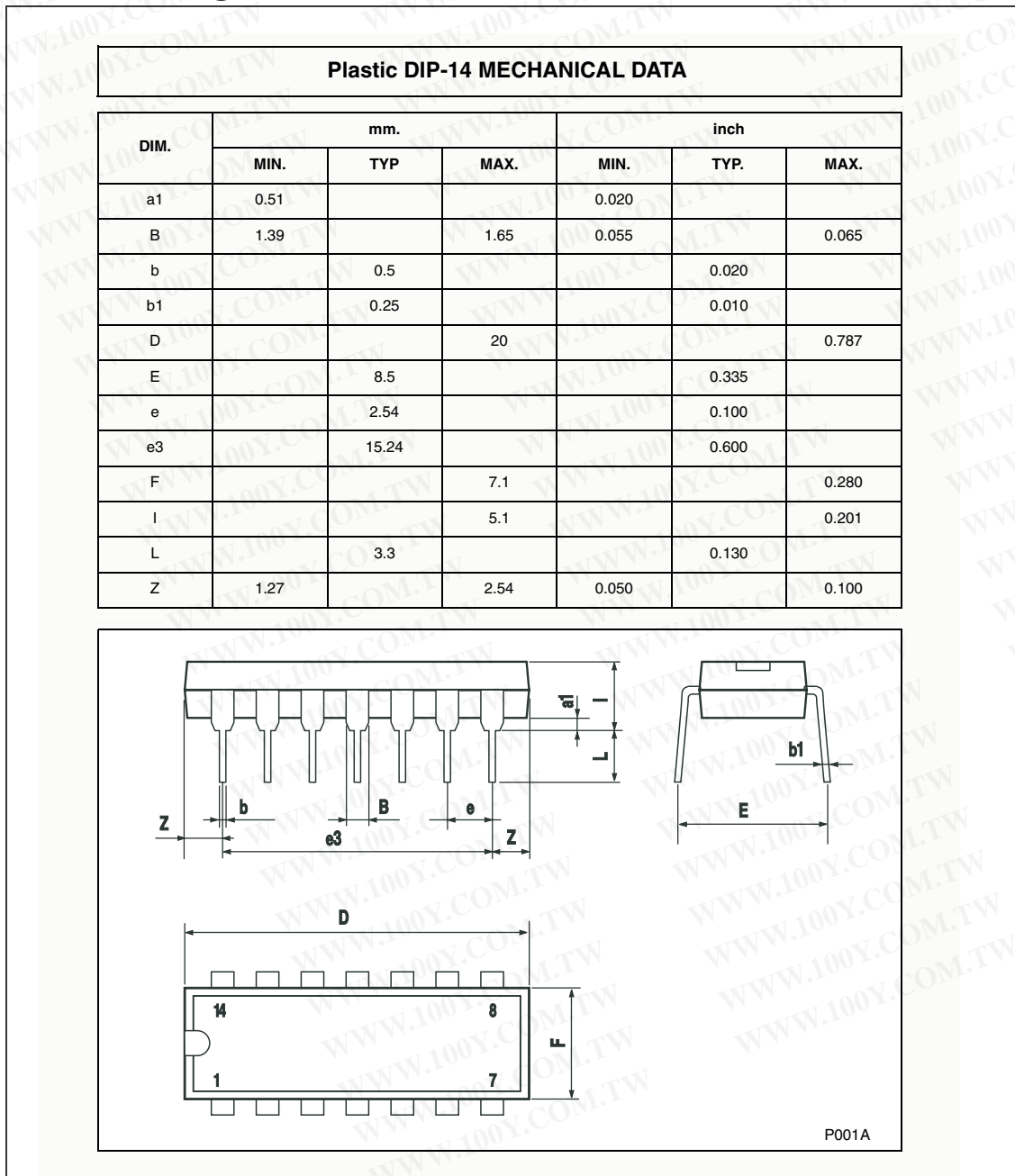

6.2 SO-14 Package

SO-14 MECHANICAL DATA						
DIM.	mm.			inch		
	MIN.	TYP.	MAX.	MIN.	TYP.	MAX.
A			1.75			0.068
a1	0.1		0.2	0.003		0.007
a2			1.65			0.064
b	0.35		0.46	0.013		0.018
b1	0.19		0.25	0.007		0.010
C		0.5			0.019	
c1	45° (typ.)					
D	8.55		8.75	0.336		0.344
E	5.8		6.2	0.228		0.244
e		1.27			0.050	
e3		7.62			0.300	
F	3.8		4.0	0.149		0.157
G	4.6		5.3	0.181		0.208
L	0.5		1.27	0.019		0.050
M			0.68			0.026
S	8° (max.)					

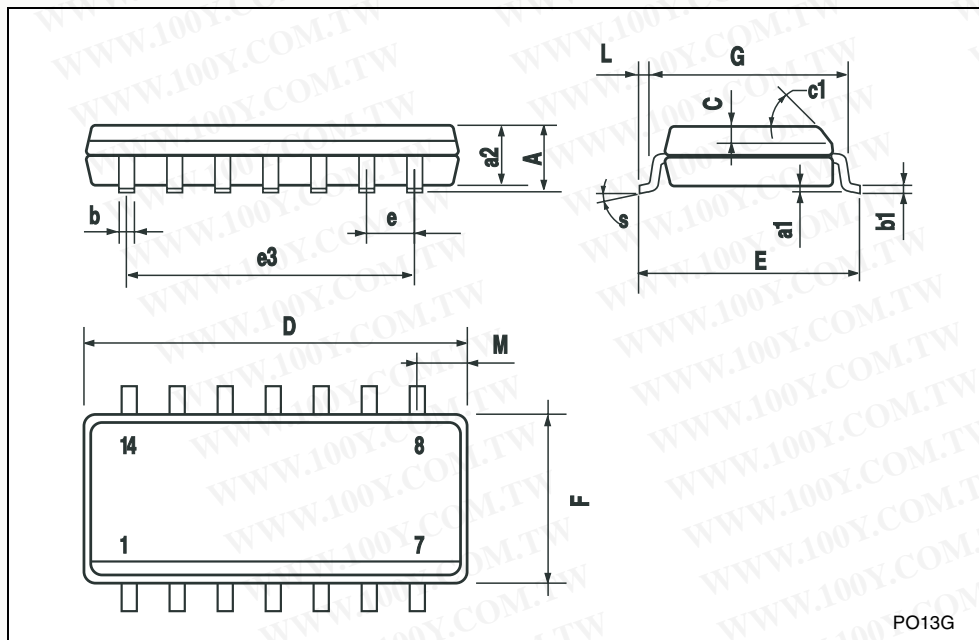

6.3 TSSOP14 Package

TSSOP14 MECHANICAL DATA

DIM.	mm.			inch		
	MIN.	TYP.	MAX.	MIN.	TYP.	MAX.
A			1.2			0.047
A1	0.05		0.15	0.002	0.004	0.006
A2	0.8	1	1.05	0.031	0.039	0.041
b	0.19		0.30	0.007		0.012
c	0.09		0.20	0.004		0.0089
D	4.9	5	5.1	0.193	0.197	0.201
E	6.2	6.4	6.6	0.244	0.252	0.260
E1	4.3	4.4	4.48	0.169	0.173	0.176
e		0.65 BSC			0.0256 BSC	
K	0°		8°	0°		8°
L	0.45	0.60	0.75	0.018	0.024	0.030

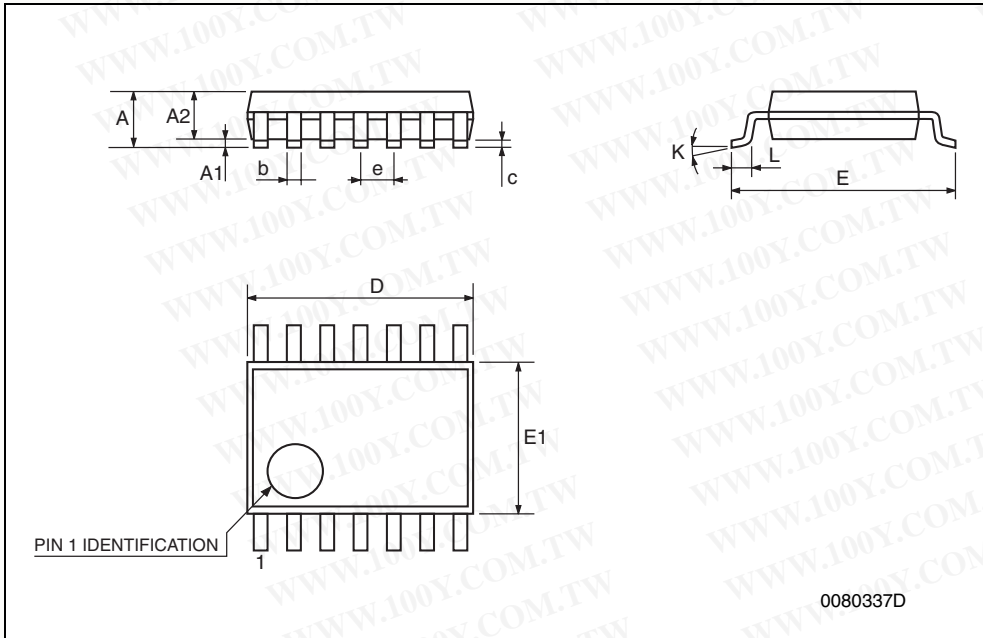

7 Revision History

Date	Revision	Changes
Oct. 2003	1	First Release
Jan. 2005	2	Modifications on AMR <i>Table 1 on page 2</i> (explanation of Vid and Vi limits)
June 2005	3	ESD protection inserted in <i>Table 1 on page 2</i>

勝特力材料 886-3-5753170
 勝特力电子(上海) 86-21-54151736
 勝特力电子(深圳) 86-755-83298787
[Http://www.100y.com.tw](http://www.100y.com.tw)

Information furnished is believed to be accurate and reliable. However, STMicroelectronics assumes no responsibility for the consequences of use of such information nor for any infringement of patents or other rights of third parties which may result from its use. No license is granted by implication or otherwise under any patent or patent rights of STMicroelectronics. Specifications mentioned in this publication are subject to change without notice. This publication supersedes and replaces all information previously supplied. STMicroelectronics products are not authorized for use as critical components in life support devices or systems without express written approval of STMicroelectronics.

The ST logo is a registered trademark of STMicroelectronics.
All other names are the property of their respective owners

© 2005 STMicroelectronics - All rights reserved

STMicroelectronics group of companies

Australia - Belgium - Brazil - Canada - China - Czech Republic - Finland - France - Germany - Hong Kong - India - Israel - Italy - Japan - Malaysia - Malta - Morocco - Singapore - Spain - Sweden - Switzerland - United Kingdom - United States of America

www.st.com