

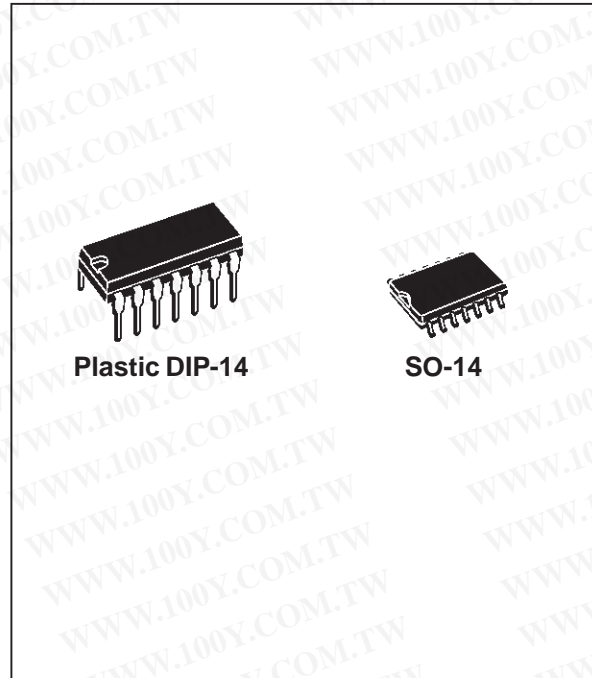

LM723

HIGH PRECISION VOLTAGE REGULATOR

- INPUT VOLTAGE UP TO 40V
- OUTPUT VOLTAGE ADJUSTABLE FROM 2 TO 37V
- POSITIVE OR NEGATIVE SUPPLY OPERATION
- SERIES, SHUNT, SWITCHING OR FLOATING OPERATION
- OUTPUT CURRENT TO 150mA WITHOUT EXTERNAL PASS TRANSISTOR
- ADJUSTABLE CURRENT LIMITING



DESCRIPTION

The LM723 is a monolithic integrated programmable voltage regulator, assembled in 14-lead dual in-line plastic and SO-14 micropackage. The circuit provides internal current limiting. When the output current exceeds 150mA an external NPN or PNP pass element may be used. Provisions are made for adjustable current limiting and remote shut-down.

BLOCK DIAGRAM

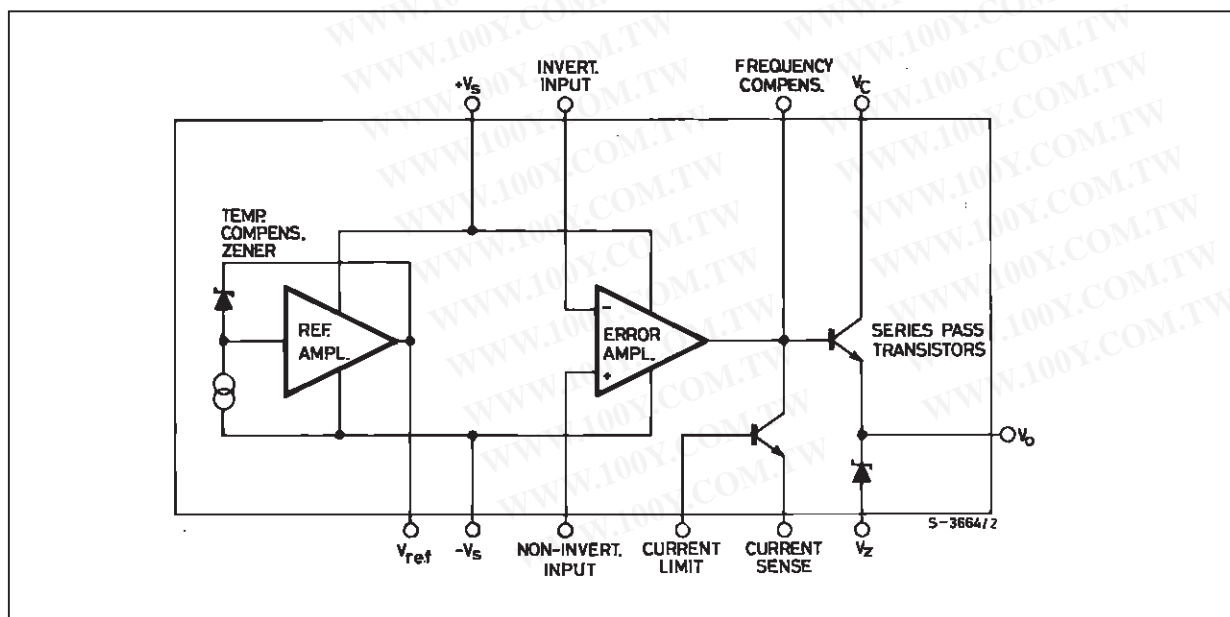

勝特力材料 886-3-5753170
 勝特力电子(上海) 86-21-54151736
 勝特力电子(深圳) 86-755-83298787
[Http://www.100y.com.tw](http://www.100y.com.tw)

LM723

ABSOLUTE MAXIMUM RATINGS

Symbol	Parameter	Value		Unit
		LM723	LM723C	
V_i	DC Input Voltage	40	40	V
ΔV_{i-o}	Dropout Voltage	40	40	V
I_o	Output Current	150	150	mA
I_{ref}	Current from V_{ref}	15	25	mA
T_{op}	Operating Temperature	-55 to 125	0 to 70	$^{\circ}C$
T_{stg}	Storage Temperature	-65 to 150	-65 to 150	$^{\circ}C$
T_j	Junction Temperature	150	125	$^{\circ}C$

ABSOLUTE MAXIMUM RATINGS

Symbol	Parameter	Plastic DIP-14	SO-14	Unit
$R_{thj-amb}$	Thermal Resistance Junction-Ambient	Max 200	160	$^{\circ}C/W$

PIN CONNECTION (top views)

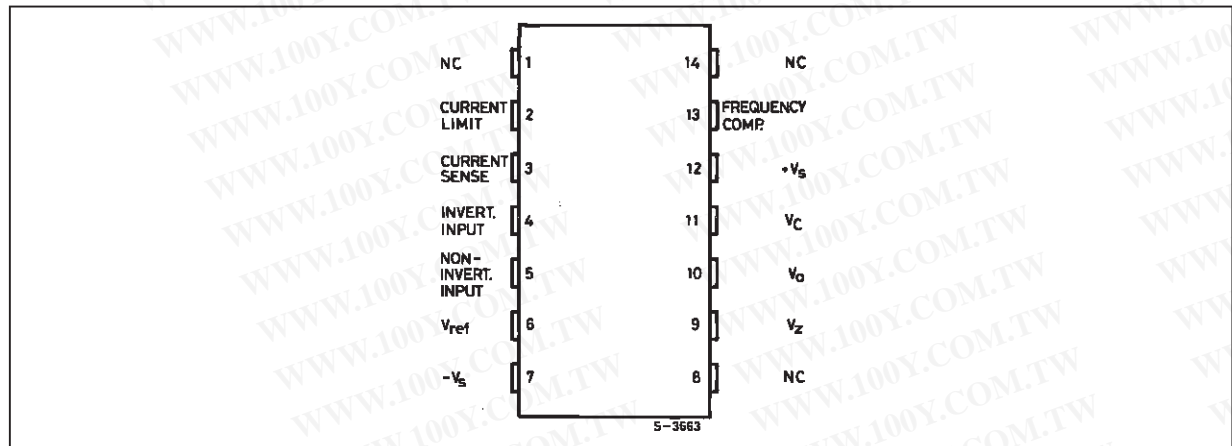

ORDER CODES

Type	Plastic DIP-14	SO-14
LM723 LM723C	LM723N LM723CN	LM723CD

TEST CIRCUIT (pin configuration relative to the plastic package)

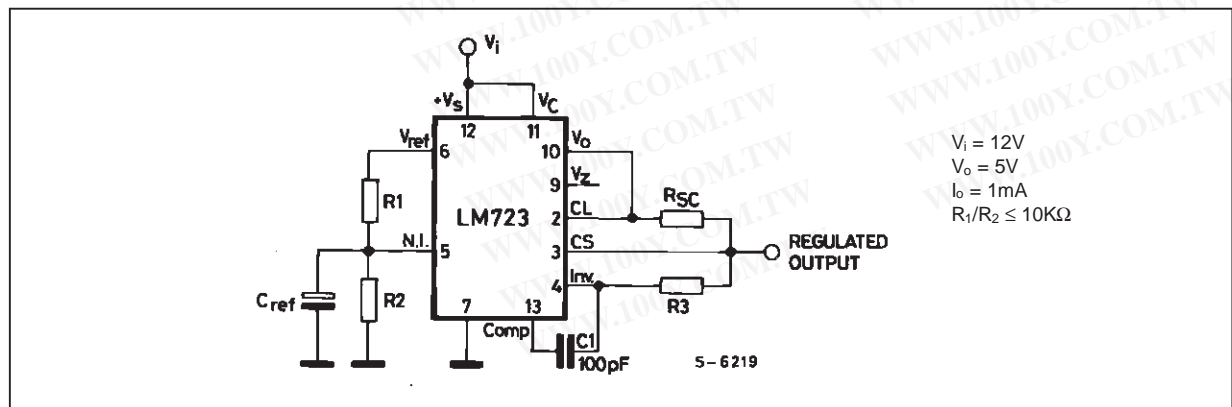

ELECTRICAL CHARACTERISTICS FOR LM723 (refer to the test circuits, $T_{amb} = 25^{\circ}\text{C}$, unless otherwise specified)

Symbol	Parameter	Test Conditions	Min.	Typ.	Max.	Unit
$\Delta V_o/\Delta V_i$	Line Regulation	$V_i = 12$ to 15V		0.01	0.1	%
		$V_i = 12$ to 40V		0.02	0.2	%
		$V_i = 12$ to 15V $-55^{\circ}\text{C} \leq T_{amb} \leq 125^{\circ}\text{C}$				0.3
$\Delta V_o/V_o$	Load Regulation	$I_o = 1$ to 50mA		0.03	0.15	%
		$I_o = 1$ to 10mA $-55^{\circ}\text{C} \leq T_{amb} \leq 125^{\circ}\text{C}$				0.6
V_{REF}	Reference Voltage	$I_{ref} = 160\ \mu\text{A}$	6.95	7.15	7.35	V
SVR	Supply Voltage Rejection	$f = 100\text{Hz}$ to 10KHz $C_{ref} = 0$		74		dB
		$f = 100\text{Hz}$ to 10KHz $C_{ref} = 5\ \mu\text{F}$		86		dB
$\Delta V_o/\Delta T$	Output Voltage Drift				150	ppm/ $^{\circ}\text{C}$
I_{sc}	Output Current Limit	$R_{sc} = 10\ \Omega$ $V_o = 0$		65		mA
V_i	Input Voltage Range		9.5		40	V
V_o	Output Voltage Range		2		37	V
$V_o - V_i$			3		38	V
I_d	Quiescent Current	$V_i = 30\text{V}$ $I_o = 0\text{mA}$		2.3	5	mA
K_{VH}	Long Term Stability			0.1		%/1000 hrs
e_N	Output Noise Voltage	$BW = 100\text{Hz}$ to 10KHz $C_{ref} = 0$		20		μV
		$BW = 100\text{Hz}$ to 10KHz $C_{ref} = 5\ \mu\text{F}$		2.5		μV

ELECTRICAL CHARACTERISTICS FOR LM723C (refer to the test circuits, $T_{amb} = 25^{\circ}\text{C}$, unless otherwise specified)

Symbol	Parameter	Test Conditions	Min.	Typ.	Max.	Unit
$\Delta V_o/\Delta V_i$	Line Regulation	$V_i = 12$ to 15V		0.01	0.1	%
		$V_i = 12$ to 40V		0.1	0.5	%
		$V_i = 12$ to 15V $0^{\circ}\text{C} \leq T_{amb} \leq 70^{\circ}\text{C}$				0.3
$\Delta V_o/V_o$	Load Regulation	$I_o = 1$ to 50mA		0.03	0.2	%
		$I_o = 1$ to 10mA $0^{\circ}\text{C} \leq T_{amb} \leq 70^{\circ}\text{C}$				0.6
V_{REF}	Reference Voltage	$I_{ref} = 160\ \mu\text{A}$	6.8	7.15	7.5	V
SVR	Supply Voltage Rejection	$f = 100\text{Hz}$ to 10KHz $C_{ref} = 0$		74		dB
		$f = 100\text{Hz}$ to 10KHz $C_{ref} = 5\ \mu\text{F}$		86		dB
$\Delta V_o/\Delta T$	Output Voltage Drift				150	ppm/ $^{\circ}\text{C}$
I_{sc}	Output Current Limit	$R_{sc} = 10\ \Omega$ $V_o = 0$		65		mA
V_i	Input Voltage Range		9.5		40	V
V_o	Output Voltage Range		2		37	V
$V_o - V_i$			3		38	V
I_d	Quiescent Current	$V_i = 30\text{V}$ $I_o = 0\text{mA}$		2.3	4	mA
K_{VH}	Long Term Stability			0.1		%/1000 hrs
e_N	Output Noise Voltage	$BW = 100\text{Hz}$ to 10KHz $C_{ref} = 0$		20		μV
		$BW = 100\text{Hz}$ to 10KHz $C_{ref} = 5\ \mu\text{F}$		2.5		μV

LM723

Figure 1 : Maximum Output Current vs. Voltage Drop.

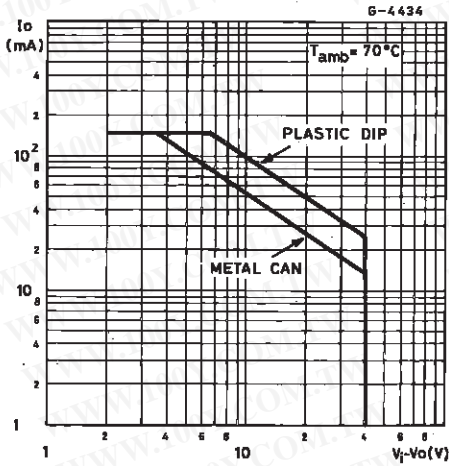

Figure 2 : Current Limiting Characteristics.

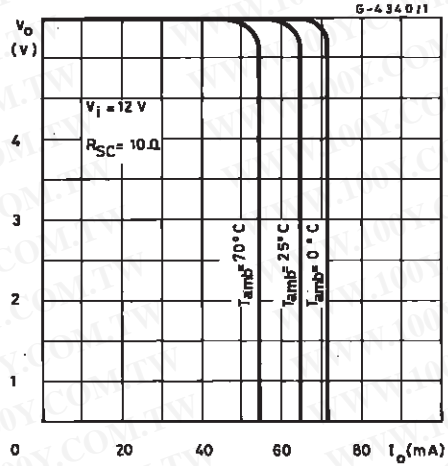

Figure 3 : Current Limiting Characteristics vs. Junction Temperature.

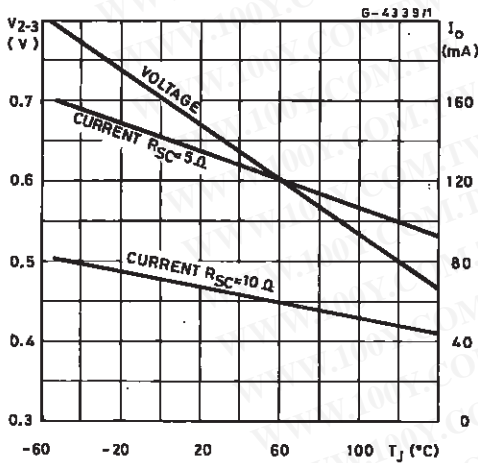

Figure 4 : Load Regulation Characteristics without Current Limiting.

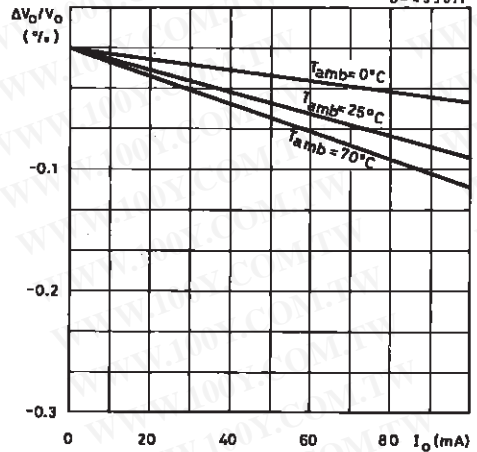

Figure 5 : Load Regulation Characteristics with Current Limiting.

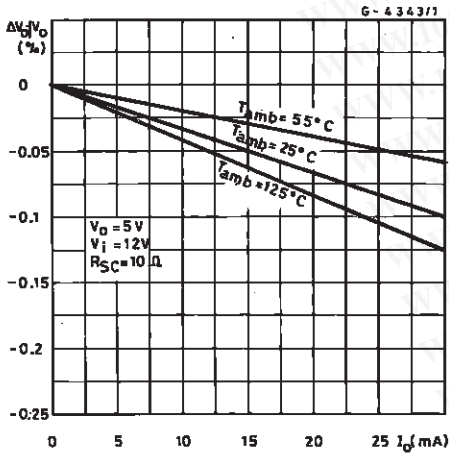

Figure 6 : Load Regulation Characteristics with Current Limiting.

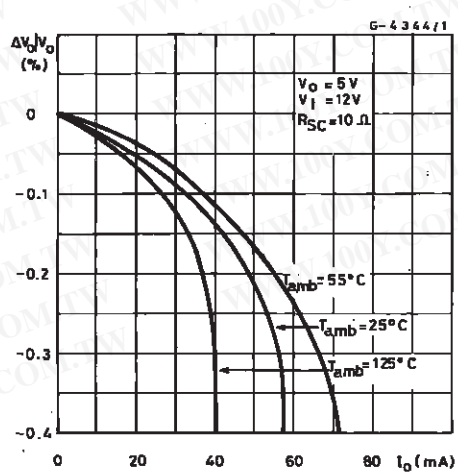

Figure 7 : Line Regulation vs. Voltage Drop.

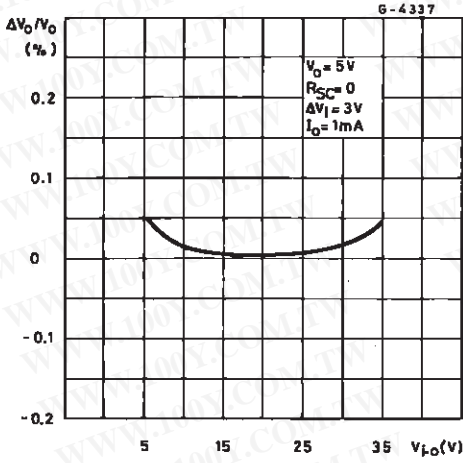

Figure 8 : Load Regulation vs. Voltage Drop.

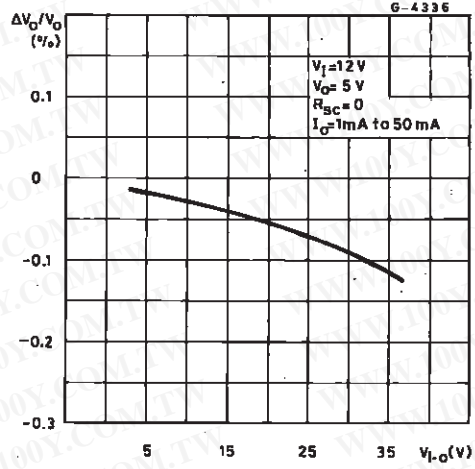

Figure 9 : Quiescent Drain Current vs. Input Voltage.

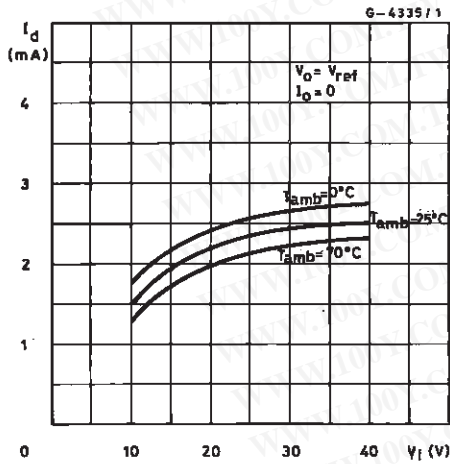

Figure 10 : Line Transient Response.

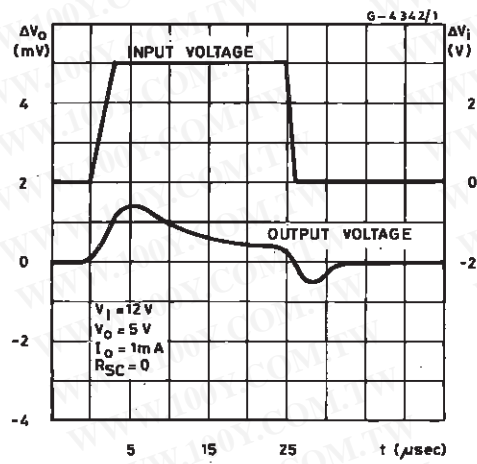

Figure 11 : Load Transient Response.

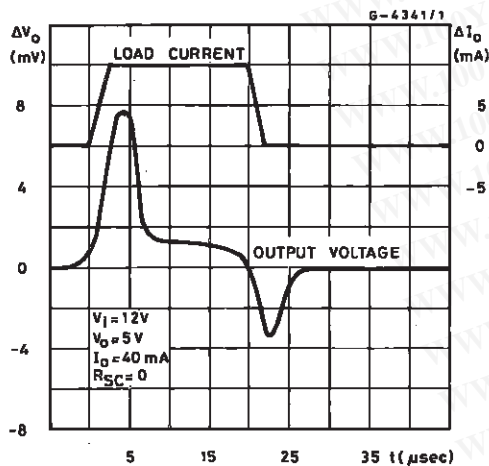
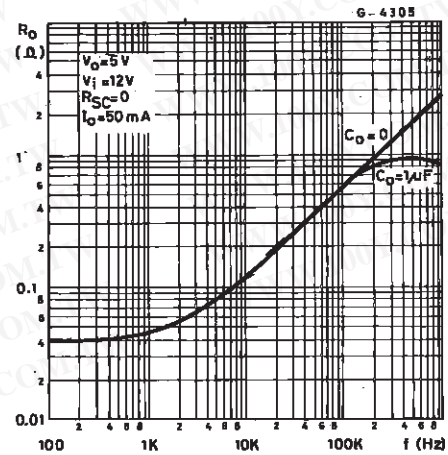

Figure 12 : Output Impedance vs. Frequency.



LM723

TABLE 1: Resistor Values (KΩ) for standard Output Voltages

Output Voltage	Applicable Figures	Fixed Output ± 5%		Output Adjustable ± 10% *		
		R1	R2	R1	P1	R2
+3	13, 16, 17, 18, 21, 23	4.12	3.01	1.8	0.5	1.2
+5	13, 16, 17, 18, 21, 23	2.15	4.99	0.75	0.5	2.2
+6	13, 16, 17, 18, 21, 23	1.15	6.04	0.5	0.5	2.7
+9	14, 16, 17, 18, 21, 23	1.87	7.15	0.75	1	2.7
+12	14, 16, 17, 18, 21, 23	4.87	7.15	2	1	3
+15	14, 16, 17, 18, 21, 23	7.87	7.15	3.3	1	3
+28	14, 16, 17, 18, 21, 23	21	7.15	5.6	1	2
+45	19	3.57	48.7	2.2	10	39
+75	19	3.57	78.7	2.2	10	68
+100	19	3.57	102	2.2	10	91
+250	19	3.57	255	2.2	10	240
-6**	15	3.57	2.43	1.2	0.5	0.75
-9	15	3.48	5.36	1.2	0.5	2
-12	15	3.57	8.45	1.2	0.5	3.3
-15	15	3.65	11.5	1.2	0.5	4.3
-28	15	3.57	24.3	1.2	0.5	10
-45	20	3.57	21.2	2.2	10	33
-100	20	3.57	97.6	2.2	10	91
-250	20	3.57	249	2.2	10	240

Note:

* Replace R1/R2 divider with the circuit of fig24.

** V+ must be connected to a +3V or greater supply.

TABLE 2: Formulae for Intermediate Output Voltages

Outputs from +2 to +7V Fig.13, 16, 17, 18, 21, 23 $V_O = \left[V_{ref} \times \frac{R_2}{R_1 + R_2} \right]$	Outputs from +4 to +250V Fig.19 $V_O = \left[\frac{V_{ref}}{2} \times \frac{R_2 - R_1}{R_1} \right]; R_3 = R_4$	Current Limiting $I_{LIMIT} = \frac{V_{SENSE}}{R_{sc}}$
Outputs from +7 to +37V Fig.14, 16, 17, 18, 21, 23 $V_O = \left[V_{ref} \times \frac{R_1 + R_2}{R_2} \right]$	Outputs from -6 to -250V Fig.15, 20 $V_O = \left[\frac{V_{ref}}{2} \times \frac{R_1 + R_2}{R_1} \right]; R_3 = R_4$	Foldback Current Limiting $I_{KNEE} = \left[\frac{V_O R_3}{R_{sc} R_4} \times \frac{V_{SENSE} (R_3 + R_4)}{R_{sc} R_4} \right]$ $I_{SHORT\ CKT} = \left[\frac{V_{SENSE}}{R_{sc}} \times \frac{R_3 + R_4}{R_4} \right]$

APPLICATION INFORMATION (pin numbers relative to the plastic package).

Figure 13 : Basic Low Voltage Regulator
 ($V_o = 2$ to $7V$).

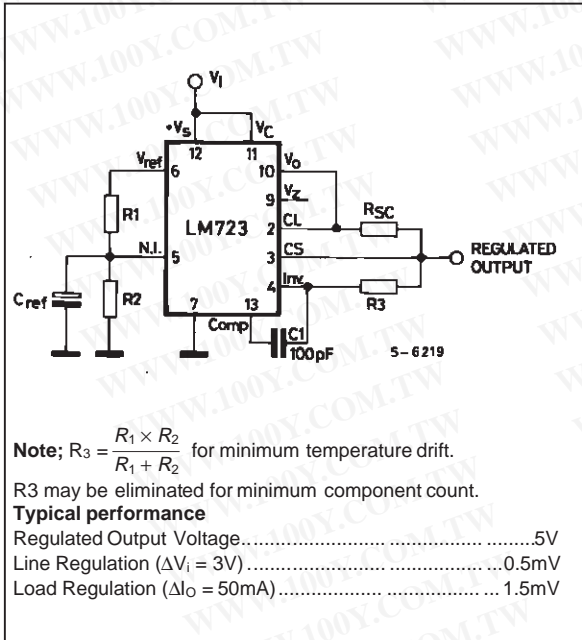

Figure 14 : Basic High Voltage Regulator
 ($V_o = 7$ to $37V$).

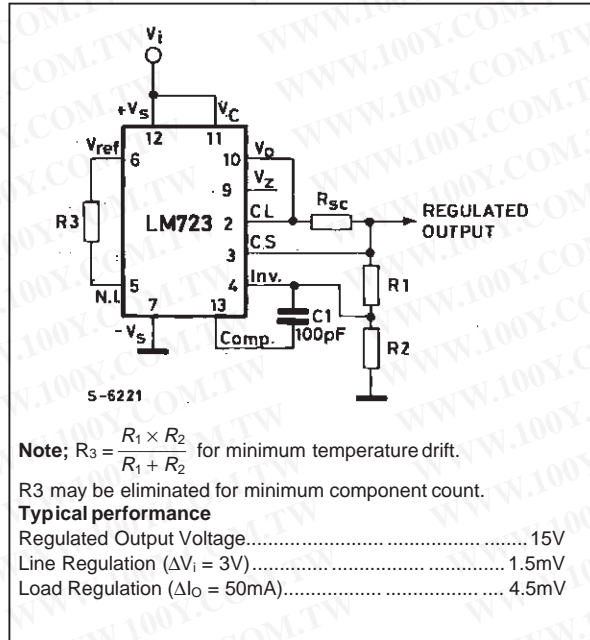

Figure 15 : Negative Voltage Regulator.

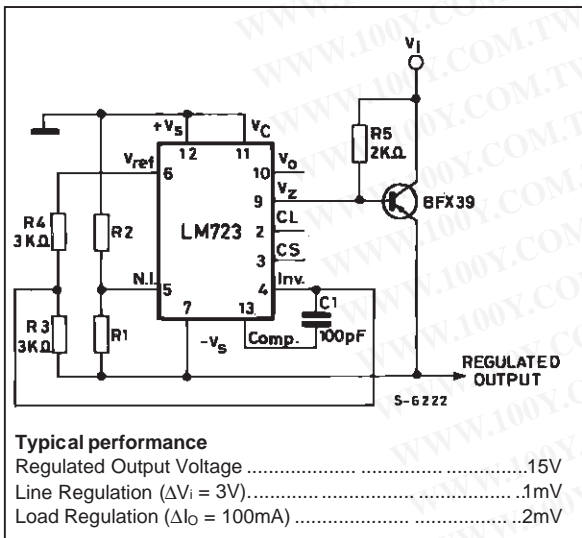
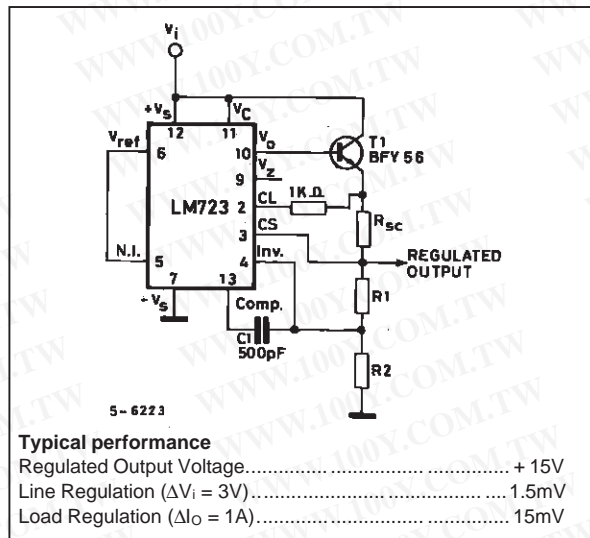

Figure 16 : Positive Voltage Regulator (external)



LM723

APPLICATION INFORMATION (continued).

Figure 17 : Positive Voltage Regulator (External PNP Pass Transistor)

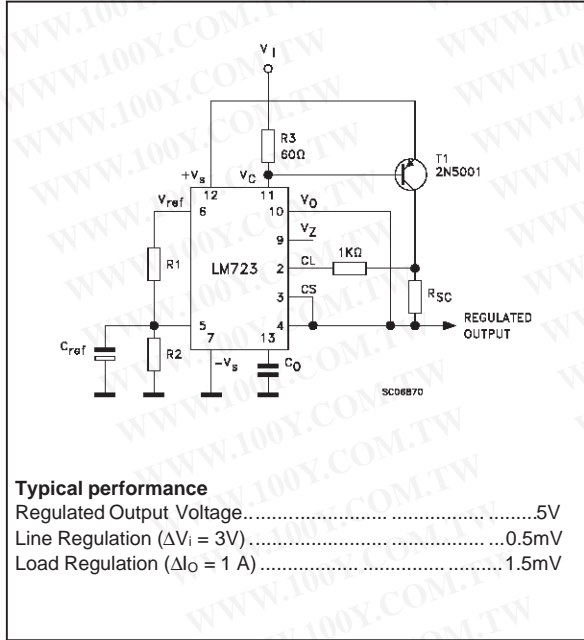

Figure 18 : Foldback current limiting

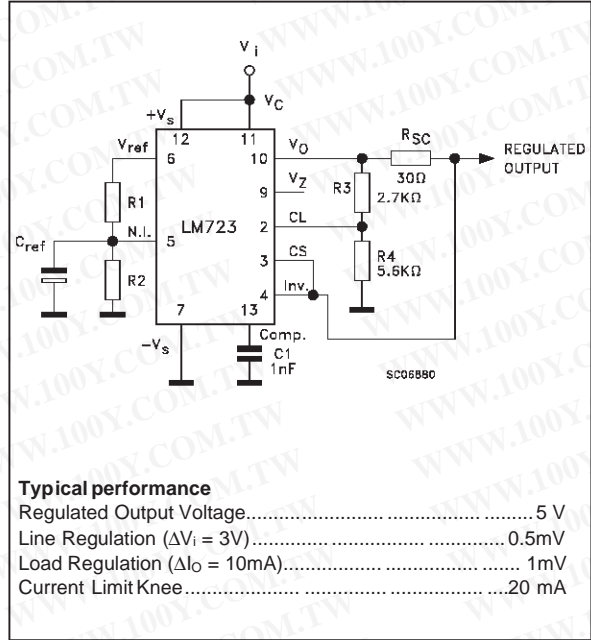

Figure 19 : Positive Floating Regulator

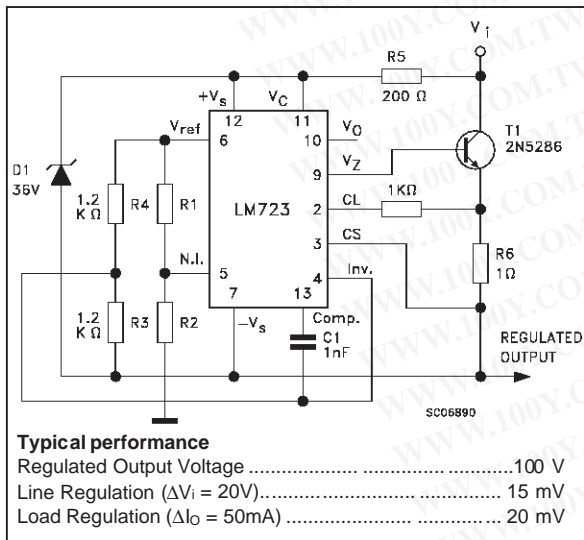
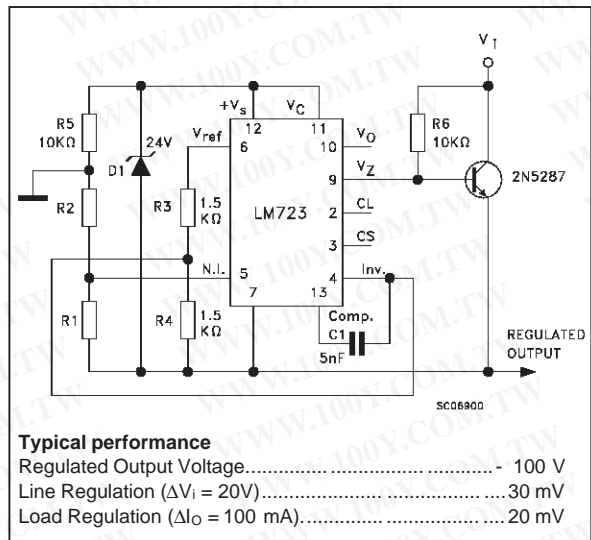

Figure 20 : Negative Floating Regulator



APPLICATION INFORMATION (continued).

Figure 21 : Positive Switching Regulator

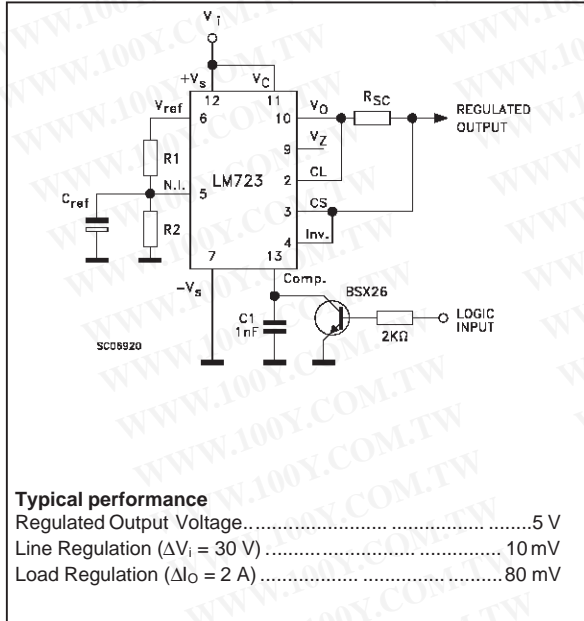

Figure 22 : Remote Shutdown Regulator With Current Limiting

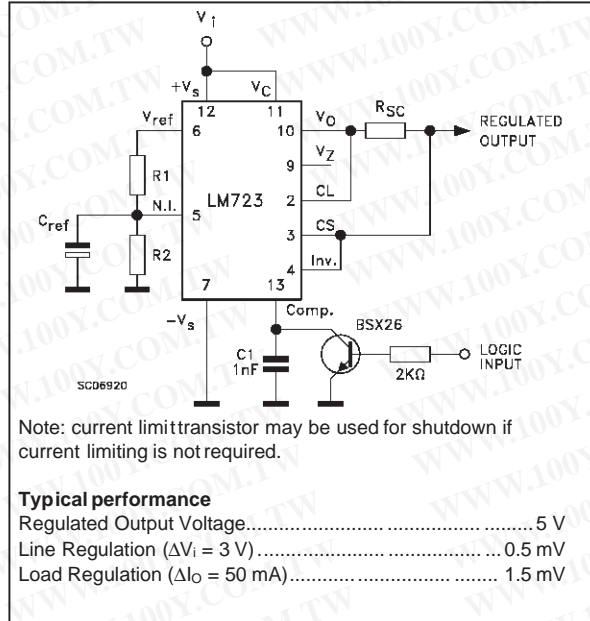

Figure 23 : Shunt Regulator.

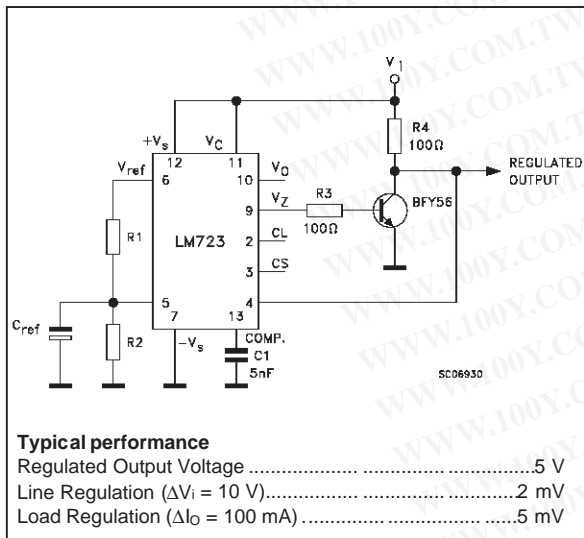
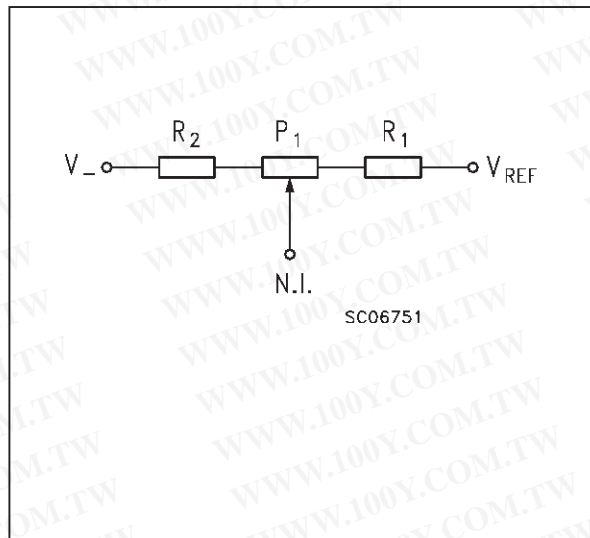

Figure 24 : Output Voltage Adjust



勝特力材料 886-3-5753170
 勝特力电子(上海) 86-21-54151736
 勝特力电子(深圳) 86-755-83298787
[Http://www.100y.com.tw](http://www.100y.com.tw)

LM723

Plastic DIP-14 MECHANICAL DATA

DIM.	mm			inch		
	MIN.	TYP.	MAX.	MIN.	TYP.	MAX.
a1	0.51			0.020		
B	1.39		1.65	0.055		0.065
b		0.5		0.020		
b1		0.25		0.010		
D			20			0.787
E		8.5		0.335		
e		2.54		0.100		
e3		15.24		0.600		
F			7.1			0.280
l			5.1			0.201
L		3.3		0.130		
Z	1.27		2.54	0.050		0.100

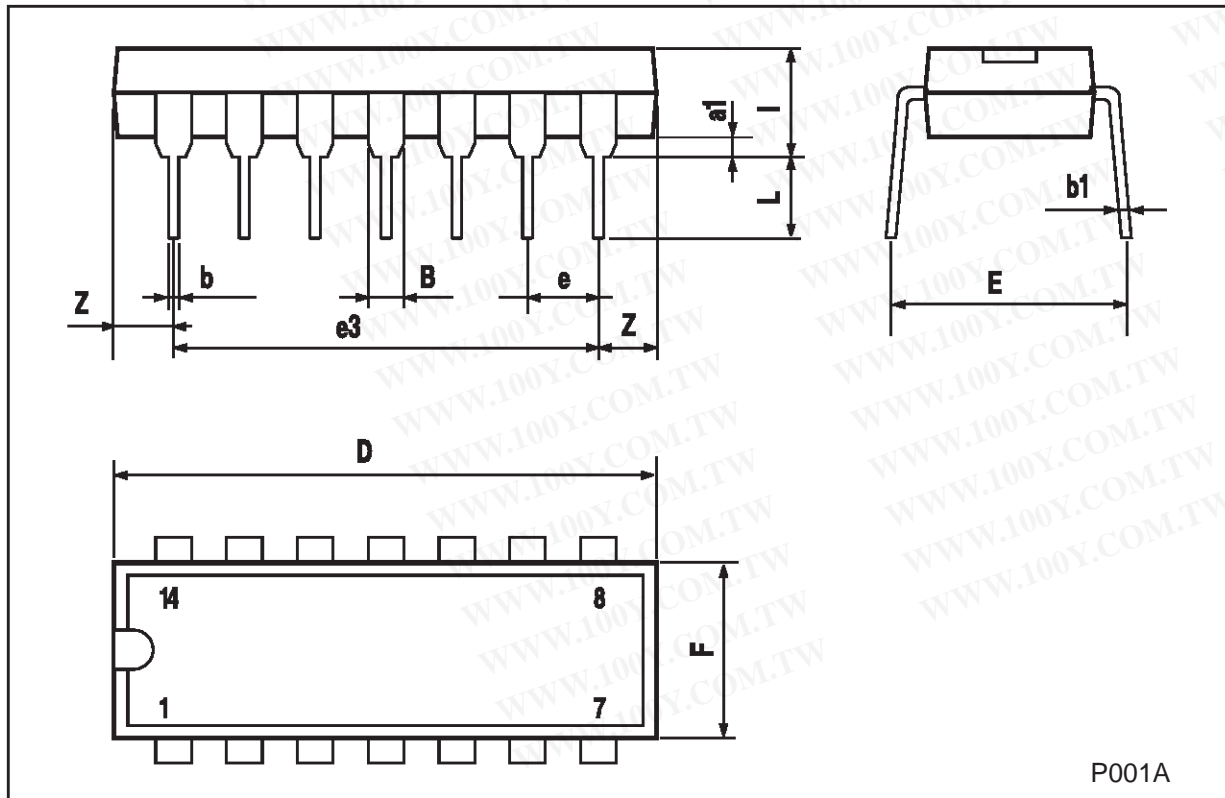

SO-14 MECHANICAL DATA

DIM.	mm			inch		
	MIN.	TYP.	MAX.	MIN.	TYP.	MAX.
A			1.75			0.068
a1	0.1		0.2	0.003		0.007
a2			1.65			0.064
b	0.35		0.46	0.013		0.018
b1	0.19		0.25	0.007		0.010
C		0.5			0.019	
c1	45 (typ.)					
D	8.55		8.75	0.336		0.344
E	5.8		6.2	0.228		0.244
e		1.27			0.050	
e3		7.62			0.300	
F	3.8		4.0	0.149		0.157
G	4.6		5.3	0.181		0.208
L	0.5		1.27	0.019		0.050
M			0.68			0.026
S	8 (max.)					

