

# DATA SHEET

勝特力材料 886-3-5753170  
勝特力电子(上海) 86-21-54151736  
勝特力电子(深圳) 86-755-83298787  
[Http://www.100y.com.tw](http://www.100y.com.tw)

## **TDA1517** **2 × 6 W stereo car radio power amplifier**

Product specification  
Supersedes data of December 1994  
File under Integrated Circuits, IC01

1995 Dec 15

**2 × 6 W stereo car radio power amplifier****TDA1517****FEATURES**

- Requires very few external components
- High output power
- Fixed gain
- Good ripple rejection
- Mute/standby switch
- Load dump protection
- AC and DC short-circuit safe to ground and  $V_P$
- Thermally protected
- Reverse polarity safe
- Capability to handle high energy on outputs ( $V_P = 0$  V)
- No switch-on/switch-off pop
- Electrostatic discharge protection
- Compatible with TDA1519 (except gain).

**GENERAL DESCRIPTION**

The TDA1517 is an integrated class-B dual output amplifier in a plastic single in-line medium power package with fin; 9 leads (SIL9MPF) and a plastic heat-dissipating dual in-line package (HDIP18). The device is primarily developed for car radio and multi-media applications.

**QUICK REFERENCE DATA**

SYMBOL	PARAMETER	CONDITIONS	MIN.	TYP.	MAX.	UNIT
$V_P$	supply voltage		6.0	14.4	18.0	V
	operating		–	–	30.0	V
	non-operating		–	–	45.0	V
	load dump protected		–	–	–	V
$I_{ORM}$	repetitive peak output current		–	–	2.5	A
$I_{q(tot)}$	total quiescent current		–	40	80	mA
$I_{sb}$	standby current		–	0.1	100	$\mu$ A
$I_{sw}$	switch-on current		–	–	40	$\mu$ A
$ Z_i $	input impedance		50	–	–	k $\Omega$
$P_o$	output power	$R_L = 4 \Omega$ ; THD = 0.5%	–	5	–	W
		$R_L = 4 \Omega$ ; THD = 10%	–	6	–	W
SVRR	supply voltage ripple rejection	$f_i = 100$ Hz to 10 kHz	48	–	–	dB
$\alpha_{cs}$	channel separation		40	–	–	dB
$G_v$	closed loop voltage gain		19	20	21	dB
$V_{no(rms)}$	noise output voltage (RMS value)		–	50	–	$\mu$ V
$T_c$	crystal temperature		–	–	150	$^{\circ}$ C

**ORDERING INFORMATION**

TYPE NUMBER	PACKAGE		
	NAME	DESCRIPTION	VERSION
TDA1517	SIL9MPF	plastic single in-line medium power package with fin; 9 leads	SOT110-1
TDA1517P	HDIP18	plastic heat-dissipating dual in-line; 18 leads	SOT398-1

# 2 × 6 W stereo car radio power amplifier

# TDA1517

## BLOCK DIAGRAM

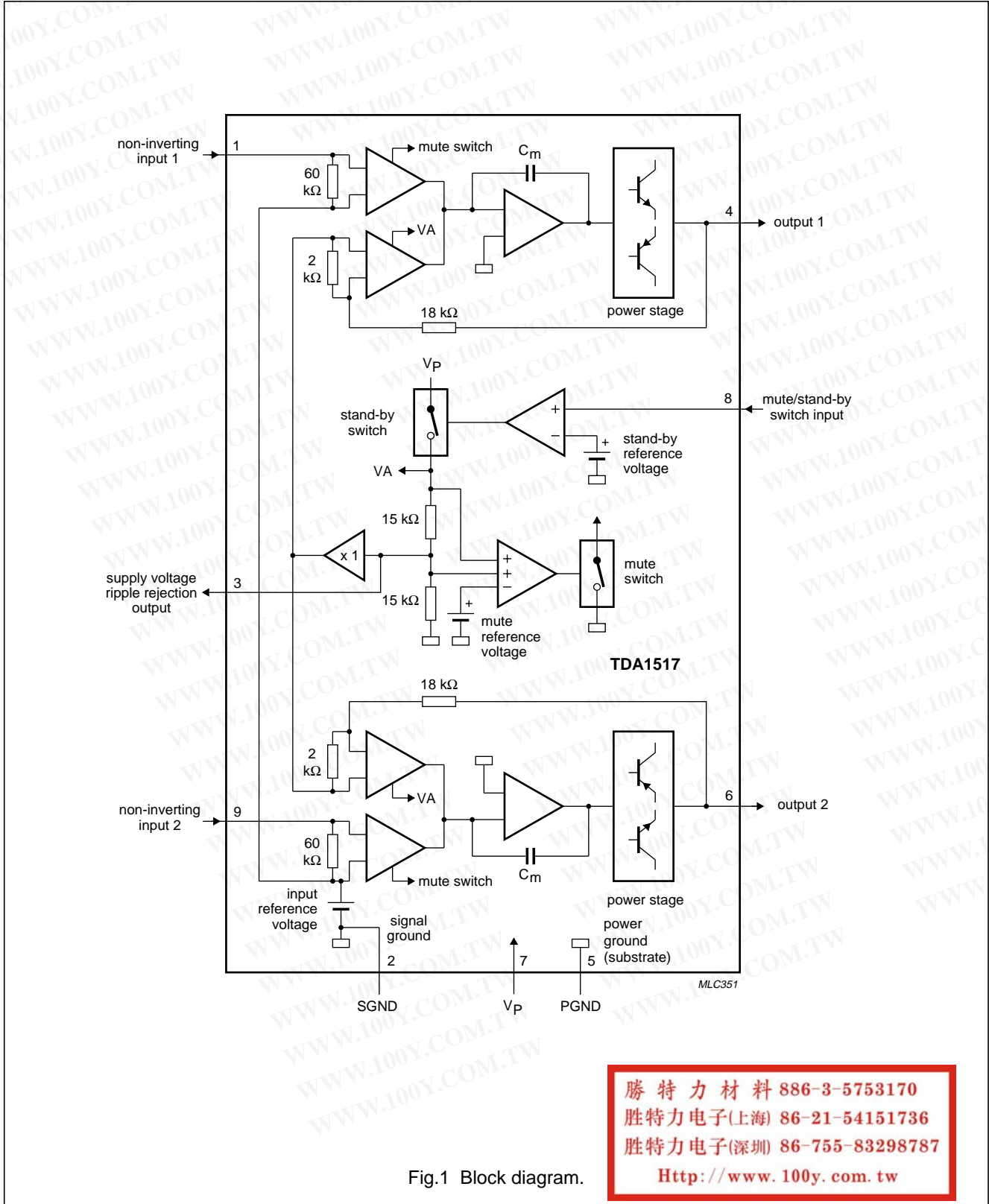

Fig.1 Block diagram.

2 × 6 W stereo car radio power amplifier

TDA1517

PINNING

SYMBOL	PIN	DESCRIPTION
-INV1	1	non-inverting input 1
SGND	2	signal ground
SVRR	3	supply voltage ripple rejection output
OUT1	4	output 1
PGND	5	power ground
OUT2	6	output 2
V <sub>P</sub>	7	supply voltage
M/SS	8	mute/standby switch input
-INV2	9	non-inverting input 2

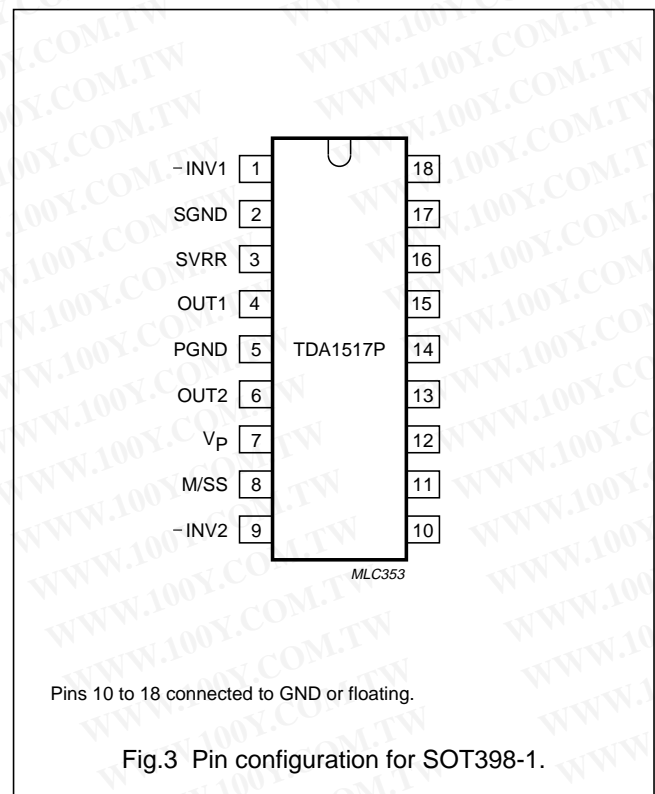
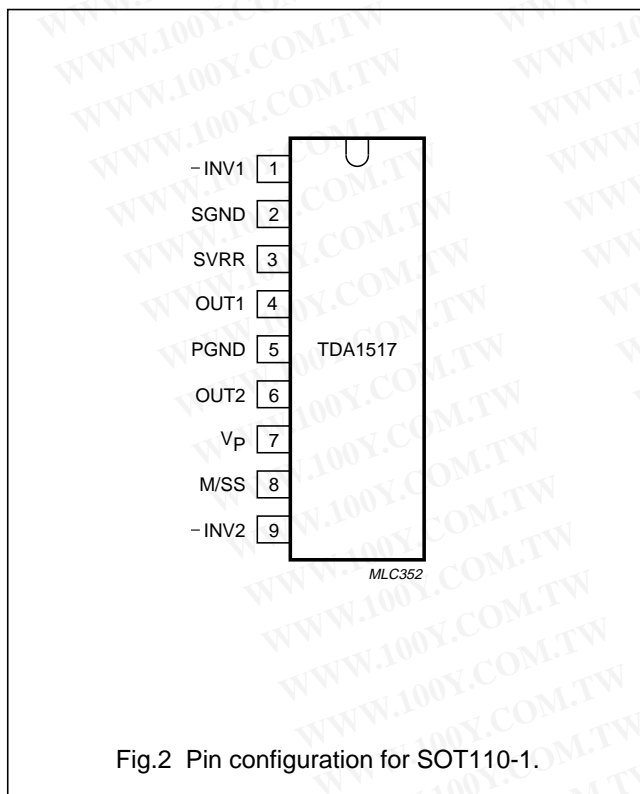

FUNCTIONAL DESCRIPTION

The TDA1517 contains two identical amplifiers with differential input stages. The gain of each amplifier is fixed at 20 dB. A special feature of the device is the mute/standby switch which has the following features:

- Low standby current (<100 μA)
- Low mute/standby switching current (low cost supply switch)
- Mute condition.

勝特力材料 886-3-5753170  
 勝特力电子(上海) 86-21-54151736  
 勝特力电子(深圳) 86-755-83298787  
[Http://www.100y.com.tw](http://www.100y.com.tw)

2 × 6 W stereo car radio power amplifier

TDA1517

**LIMITING VALUES**

In accordance with the Absolute Maximum Rating System (IEC 134).

SYMBOL	PARAMETER	CONDITIONS	MIN.	MAX.	UNIT
V <sub>P</sub>	supply voltage		–	18	V
	operating		–	30	V
	non-operating		–	45	V
	load dump protection	during 50 ms; t <sub>r</sub> ≥ 2.5 ms	–	45	V
V <sub>P(sc)</sub>	AC and DC short-circuit safe voltage		–	18	V
V <sub>P(r)</sub>	reverse polarity		–	6	V
ERG <sub>O</sub>	energy handling capability at outputs	V <sub>P</sub> = 0 V	–	200	mJ
I <sub>OSM</sub>	non-repetitive peak output current		–	4	A
I <sub>ORM</sub>	repetitive peak output current		–	2.5	A
P <sub>tot</sub>	total power dissipation	see Fig.4	–	15	W
T <sub>stg</sub>	storage temperature		–55	+150	°C
T <sub>amb</sub>	operating ambient temperature		–40	+85	°C
T <sub>c</sub>	crystal temperature		–	150	°C

**THERMAL RESISTANCE**

SYMBOL	TYPE NUMBER	PARAMETER	VALUE	UNIT
R <sub>th j-c</sub>	TDA1517	thermal resistance from junction to case	8	K/W
R <sub>th j-p</sub>	TDA1517P	thermal resistance from junction to pins	15	K/W
R <sub>th j-a</sub>	TDA1517; TDA1517P	thermal resistance from junction to ambient	50	K/W

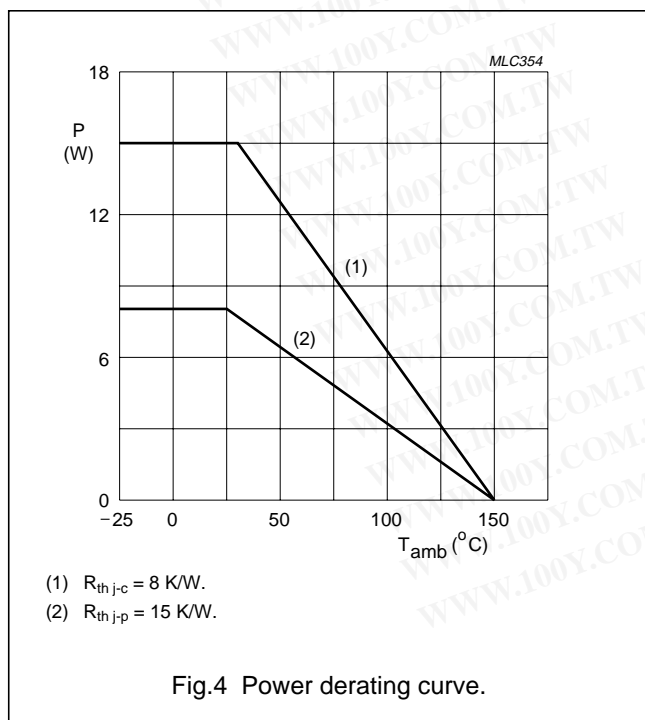

勝特力材料 886-3-5753170  
 勝特力电子(上海) 86-21-54151736  
 勝特力电子(深圳) 86-755-83298787  
[Http://www.100y.com.tw](http://www.100y.com.tw)

**2 × 6 W stereo car radio power amplifier****TDA1517****DC CHARACTERISTICS** $V_P = 14.4 \text{ V}$ ;  $T_{\text{amb}} = 25 \text{ }^\circ\text{C}$ ; measured in Fig.6; unless otherwise specified.

SYMBOL	PARAMETER	CONDITIONS	MIN.	TYP.	MAX.	UNIT
<b>Supply</b>						
$V_P$	supply voltage	note 1	6.0	14.4	18.0	V
$I_{q(\text{tot})}$	total quiescent current		–	40	80	mA
$V_O$	DC output voltage	note 2	–	6.95	–	V
<b>Mute/standby switch</b>						
$V_8$	switch-on voltage level	see Fig.5	8.5	–	–	V
<b>Mute condition</b>						
$V_O$	output signal in mute position	$V_{l(\text{max})} = 1 \text{ V}$ ; $f_i = 20 \text{ Hz to } 15 \text{ kHz}$	–	–	2	mV
<b>Standby condition</b>						
$I_{\text{sb}}$	DC current in standby condition		–	–	100	$\mu\text{A}$
$V_{\text{sw}}$	switch-on current		–	12	40	$\mu\text{A}$

**Notes**

1. The circuit is DC adjusted at  $V_P = 6$  to  $18 \text{ V}$  and AC operating at  $V_P = 8.5$  to  $18 \text{ V}$ .
2. At  $18 \text{ V} < V_P < 30 \text{ V}$  the DC output voltage  $\leq \frac{1}{2}V_P$ .

**2 × 6 W stereo car radio power amplifier****TDA1517****AC CHARACTERISTICS** $V_P = 14.4\text{ V}$ ;  $R_L = 4\ \Omega$ ;  $f = 1\text{ kHz}$ ;  $T_{\text{amb}} = 25\text{ }^\circ\text{C}$ ; measured in Fig.6; unless otherwise specified.

SYMBOL	PARAMETER	CONDITIONS	MIN.	TYP.	MAX.	UNIT
$P_o$	output power	THD = 0.5%; note 1	4	5	–	W
		THD = 10%; note 1	5.5	6.0	–	W
THD	total harmonic distortion	$P_o = 1\text{ W}$	–	0.1	–	%
$f_{lr}$	low frequency roll-off	at –3 dB; note 2	–	45	–	Hz
$f_{hr}$	high frequency roll-off	at –1 dB	20	–	–	kHz
$G_v$	closed loop voltage gain		19	20	21	dB
SVRR	supply voltage ripple rejection	note 3				
	on		48	–	–	dB
	mute		48	–	–	dB
	standby		80	–	–	dB
$ Z_i $	input impedance		50	60	75	k $\Omega$
$V_{no}$	noise output voltage					
	on	$R_s = 0\ \Omega$ ; note 4	–	50	–	$\mu\text{V}$
	on	$R_s = 10\ \Omega$ ; note 4	–	70	100	$\mu\text{V}$
	mute	note 5	–	50	–	$\mu\text{V}$
$\alpha_{cs}$	channel separation	$R_s = 10\ \Omega$	40	–	–	dB
$ \Delta G_v $	channel unbalance		–	0.1	1	dB

**Notes**

- Output power is measured directly at the output pins of the IC.
- Frequency response externally fixed.
- Ripple rejection measured at the output with a source impedance of 0  $\Omega$ , maximum ripple amplitude of 2 V (p-p) and a frequency between 100 Hz and 10 kHz.
- Noise voltage measured in a bandwidth of 20 Hz to 20 kHz.
- Noise output voltage independent of  $R_s$  ( $V_i = 0\text{ V}$ ).

勝特力材料 886-3-5753170  
 勝特力电子(上海) 86-21-54151736  
 勝特力电子(深圳) 86-755-83298787  
[Http://www.100y.com.tw](http://www.100y.com.tw)

2 × 6 W stereo car radio power amplifier

TDA1517

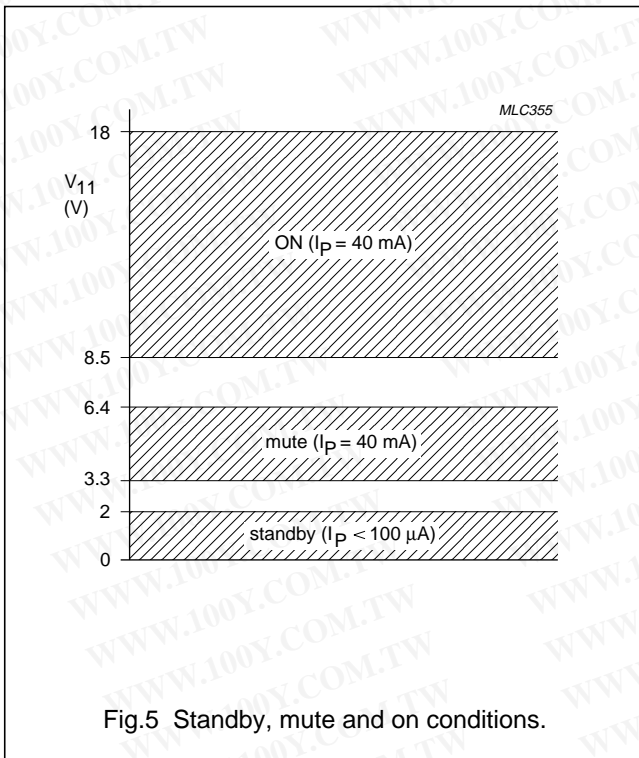

勝特力材料 886-3-5753170  
 勝特力电子(上海) 86-21-54151736  
 勝特力电子(深圳) 86-755-83298787  
[Http://www.100y.com.tw](http://www.100y.com.tw)

APPLICATION INFORMATION

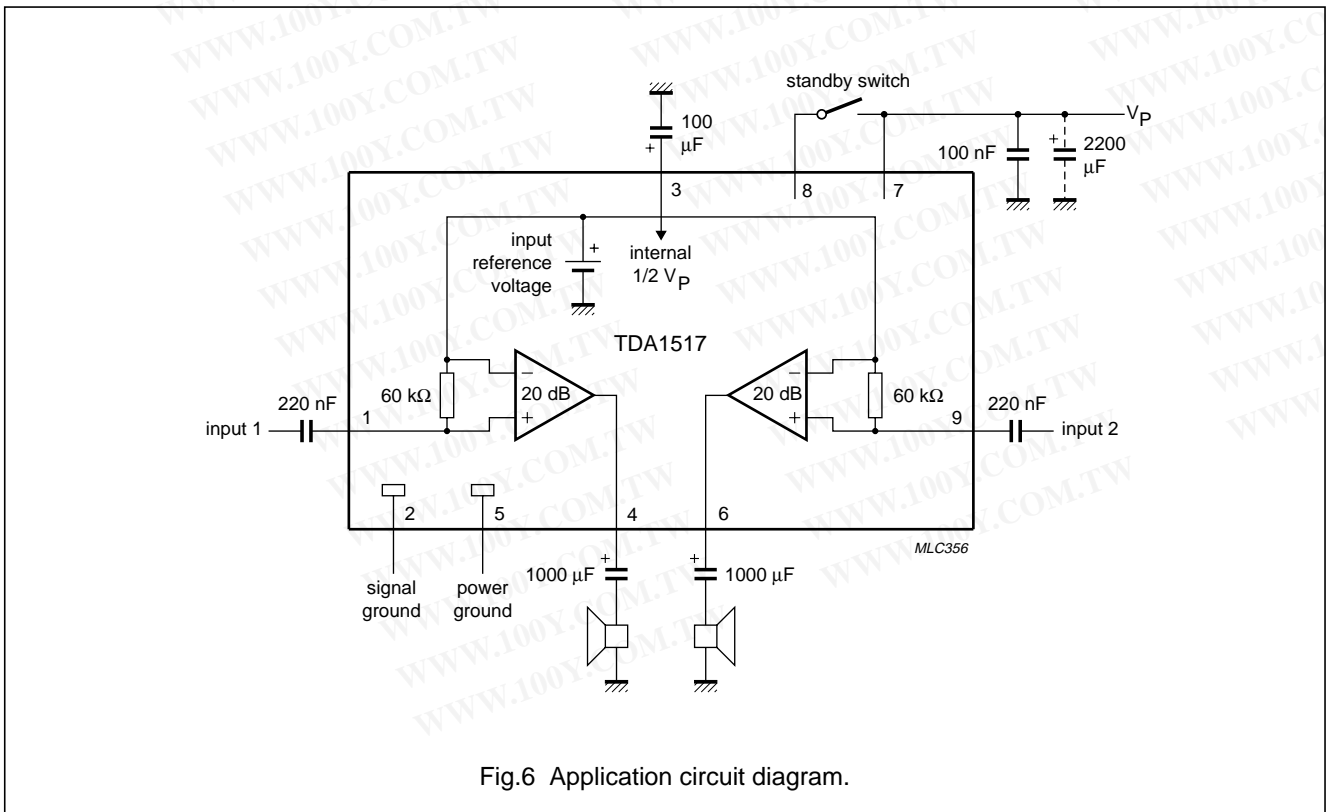



2 × 6 W stereo car radio power amplifier

TDA1517

PACKAGE OUTLINES

SIL9MPF: plastic single in-line medium power package with fin; 9 leads

SOT110-1

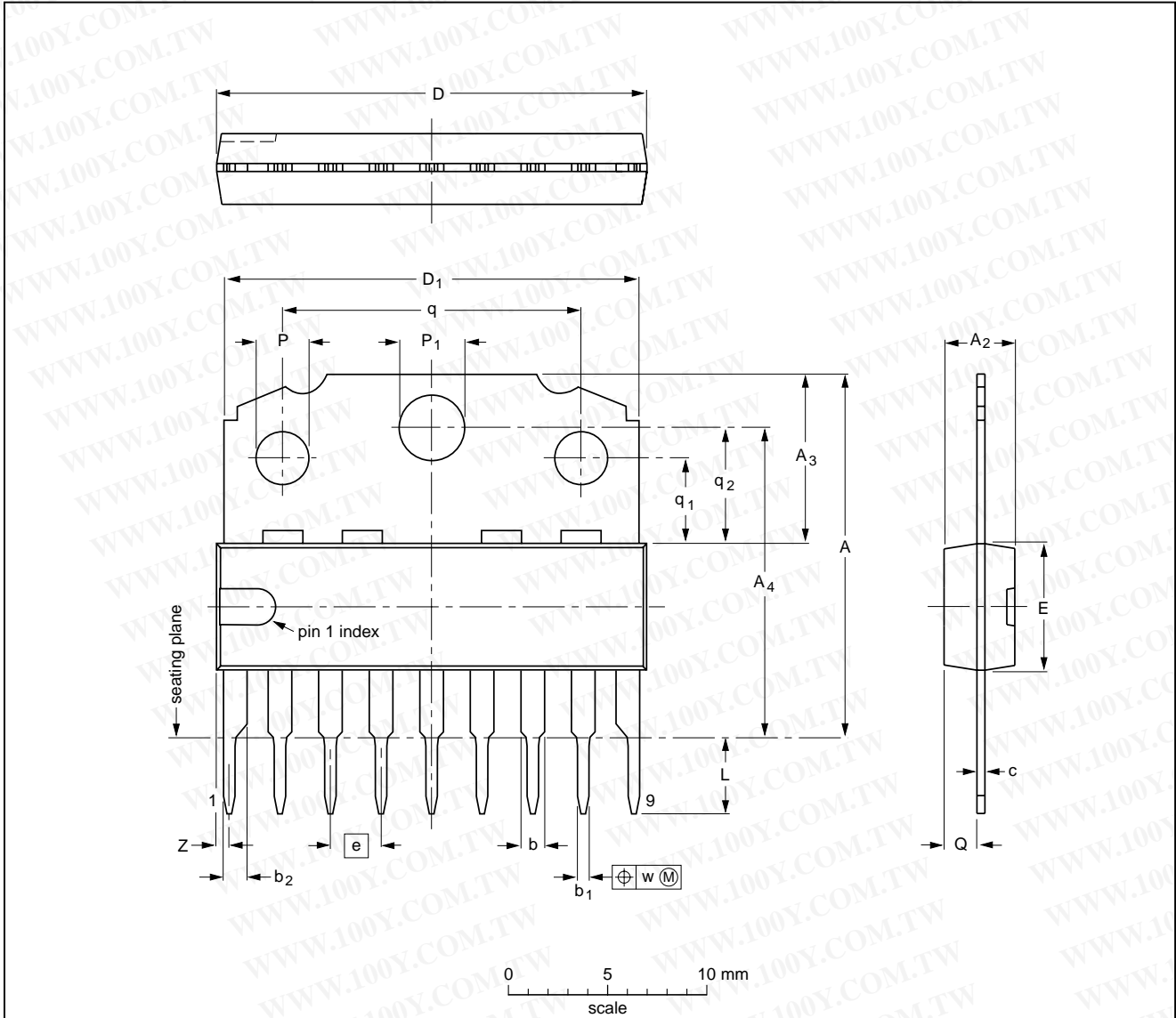

DIMENSIONS (mm are the original dimensions)

UNIT	A	A <sub>2</sub> max.	A <sub>3</sub>	A <sub>4</sub>	b	b <sub>1</sub>	b <sub>2</sub>	c	D <sup>(1)</sup>	D <sub>1</sub>	E <sup>(1)</sup>	e	L	P	P <sub>1</sub>	Q	q	q <sub>1</sub>	q <sub>2</sub>	w	Z <sup>(1)</sup> max.
mm	18.5 17.8	3.7	8.7 8.0	15.8 15.4	1.40 1.14	0.67 0.50	1.40 1.14	0.48 0.38	21.8 21.4	21.4 20.7	6.48 6.20	2.54	3.9 3.4	2.75 2.50	3.4 3.2	1.75 1.55	15.1 14.9	4.4 4.2	5.9 5.7	0.25	1.0

Note

1. Plastic or metal protrusions of 0.25 mm maximum per side are not included.

OUTLINE VERSION	REFERENCES				EUROPEAN PROJECTION	ISSUE DATE
	IEC	JEDEC	EIAJ			
SOT110-1						92-11-17 95-02-25

2 × 6 W stereo car radio power amplifier

TDA1517

HDIP18: plastic heat-dissipating dual in-line package; 18 leads

SOT398-1

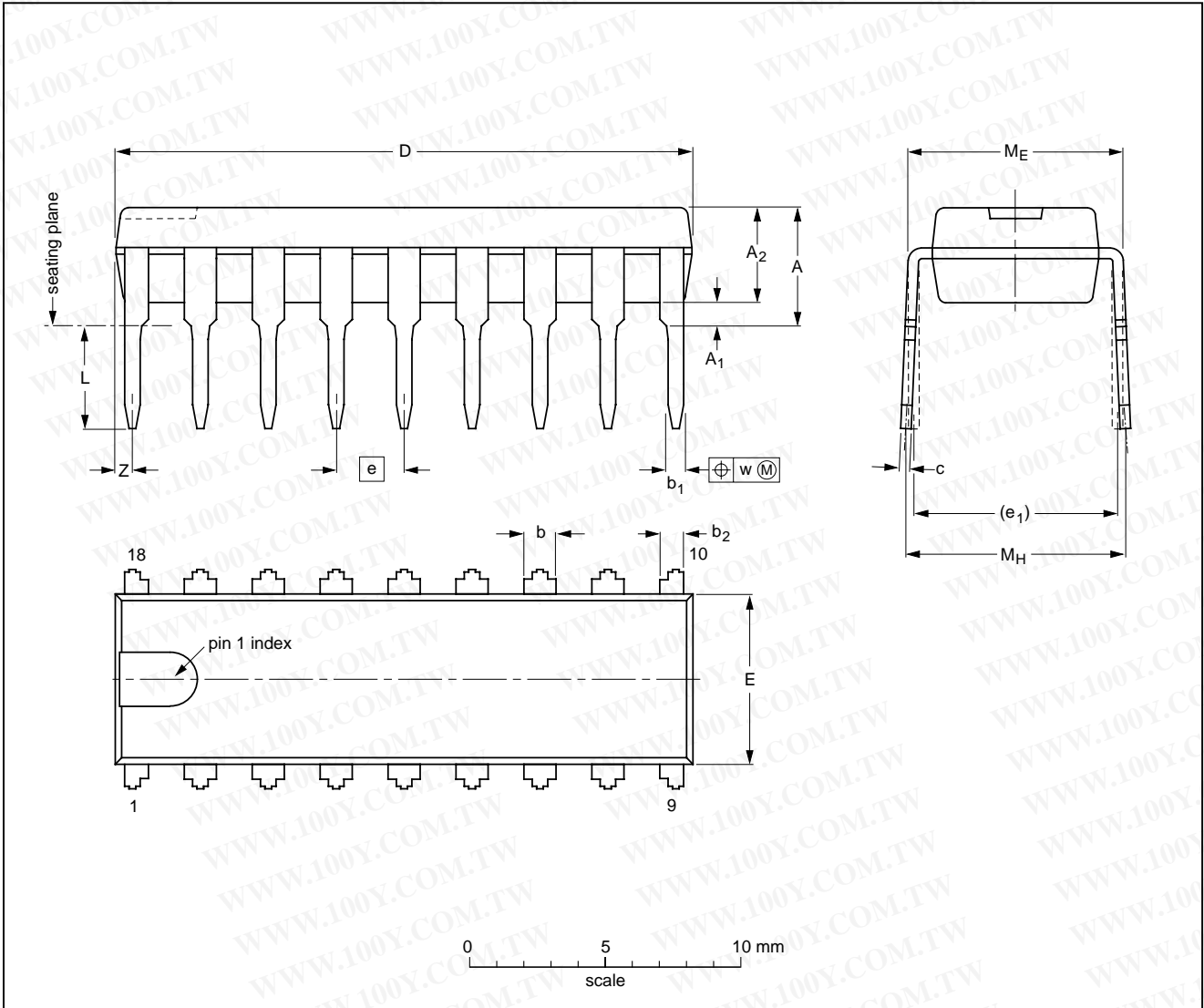

DIMENSIONS (inch dimensions are derived from the original mm dimensions)

UNIT	A max.	A <sub>1</sub> min.	A <sub>2</sub> max.	b	b <sub>1</sub>	b <sub>2</sub>	c	D <sup>(1)</sup>	E <sup>(1)</sup>	e	e <sub>1</sub>	L	M <sub>E</sub>	M <sub>H</sub>	w	Z <sup>(1)</sup> max.
mm	4.7	0.51	3.7	1.40 1.14	0.67 0.50	1.05 0.75	0.47 0.38	21.85 21.35	6.5 6.2	2.54	7.62	3.9 3.1	8.32 8.02	8.7 7.7	0.25	1.0
inches	0.19	0.02	0.15	0.06 0.04	0.03 0.02	0.04 0.03	0.02 0.01	0.87 0.84	0.26 0.24	0.10	0.30	0.15 0.12	0.33 0.32	0.34 0.30	0.01	0.04

Note

1. Plastic or metal protrusions of 0.25 mm maximum per side are not included.

OUTLINE VERSION	REFERENCES				EUROPEAN PROJECTION	ISSUE DATE
	IEC	JEDEC	EIAJ			
SOT398-1						94-04-13 95-01-25

**2 × 6 W stereo car radio power amplifier****TDA1517****SOLDERING****Introduction**

There is no soldering method that is ideal for all IC packages. Wave soldering is often preferred when through-hole and surface mounted components are mixed on one printed-circuit board. However, wave soldering is not always suitable for surface mounted ICs, or for printed-circuits with high population densities. In these situations reflow soldering is often used.

This text gives a very brief insight to a complex technology. A more in-depth account of soldering ICs can be found in our "IC Package Databook" (order code 9398 652 90011).

**Soldering by dipping or by wave**

The maximum permissible temperature of the solder is 260 °C; solder at this temperature must not be in contact

with the joint for more than 5 seconds. The total contact time of successive solder waves must not exceed 5 seconds.

The device may be mounted up to the seating plane, but the temperature of the plastic body must not exceed the specified maximum storage temperature ( $T_{stg\ max}$ ). If the printed-circuit board has been pre-heated, forced cooling may be necessary immediately after soldering to keep the temperature within the permissible limit.

**Repairing soldered joints**

Apply a low voltage soldering iron (less than 24 V) to the lead(s) of the package, below the seating plane or not more than 2 mm above it. If the temperature of the soldering iron bit is less than 300 °C it may remain in contact for up to 10 seconds. If the bit temperature is between 300 and 400 °C, contact may be up to 5 seconds.

**DEFINITIONS**

<b>Data sheet status</b>	
Objective specification	This data sheet contains target or goal specifications for product development.
Preliminary specification	This data sheet contains preliminary data; supplementary data may be published later.
Product specification	This data sheet contains final product specifications.
<b>Limiting values</b>	
Limiting values given are in accordance with the Absolute Maximum Rating System (IEC 134). Stress above one or more of the limiting values may cause permanent damage to the device. These are stress ratings only and operation of the device at these or at any other conditions above those given in the Characteristics sections of the specification is not implied. Exposure to limiting values for extended periods may affect device reliability.	
<b>Application information</b>	
Where application information is given, it is advisory and does not form part of the specification.	

**LIFE SUPPORT APPLICATIONS**

These products are not designed for use in life support appliances, devices, or systems where malfunction of these products can reasonably be expected to result in personal injury. Philips customers using or selling these products for use in such applications do so at their own risk and agree to fully indemnify Philips for any damages resulting from such improper use or sale.

勝特力材料 886-3-5753170  
 勝特力电子(上海) 86-21-54151736  
 勝特力电子(深圳) 86-755-83298787  
[Http://www.100y.com.tw](http://www.100y.com.tw)