

## FEATURES

- Switching Rates up to 32 MHz
- Operate From a Single 3.3-V Supply
- Propagation Delay Time . . . 8 ns Typ
- Pulse Skew Time . . . 500 ps Typ
- High Output-Drive Current . . .  $\pm 30$  mA
- Controlled Rise and Fall Times . . . 3 ns Typ
- Differential Output Voltage With 100- $\Omega$  Load . . . 1.5 V Typ
- Ultra-Low Power Dissipation
  - dc, 0.3 mW Max
  - 32 MHz All Channels (No Load), 385 mW Typ
- Accept 5-V Logic Inputs With 3.3-V Supply
- Low-Voltage Pin-to-Pin Compatible Replacement for AM26C31, AM26LS31, MB571
- High Output Impedance in Power-Off Condition
- Driver Output Short-Protection Circuit
- Package Options Include Plastic Small-Outline (D, NS) Packages

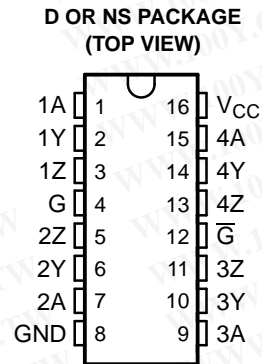

勝特力材料 886-3-5753170  
 勝特力电子(上海) 86-21-54151736  
 勝特力电子(深圳) 86-755-83298787  
[Http://www.100y.com.tw](http://www.100y.com.tw)

## DESCRIPTION/ORDERING INFORMATION

The AM26LV31C and AM26LV31I are BiCMOS quadruple differential line drivers with 3-state outputs. They are designed to be similar to TIA/EIA-422-B and ITU Recommendation V.11 drivers with reduced supply-voltage range.

The devices are optimized for balanced-bus transmission at switching rates up to 32 MHz. The outputs have very high current capability for driving balanced lines such as twisted-pair transmission lines and provide a high impedance in the power-off condition. The enable function is common to all four drivers and offers the choice of active-high or active-low enable inputs. The AM26LV31C and AM26LV31I are designed using Texas Instruments proprietary LinIMPACT-C60™ technology, facilitating ultra-low power consumption without sacrificing speed. These devices offer optimum performance when used with the AM26LV32 quadruple line receivers.

The AM26LV31C is characterized for operation from 0°C to 70°C. The AM26LV31I is characterized for operation from –45°C to 85°C

## ORDERING INFORMATION

T <sub>A</sub>	PACKAGE <sup>(1)</sup>		ORDERABLE PART NUMBER	TOP-SIDE MARKING
0°C to 70°C	SOIC – D	Tape and reel	AM26LV31CD	AM26LV31C
			AM26LV31CDR	
	SOIC – NS	Tape and reel	AM26LV31CNS	26LV31
			AM26LV31CNSR	
–45°C to 85°C	SOIC – D	Tape and reel	AM26LV31ID	AM26LV31I
			AM26LV31IDR	
	SOIC – NS	Tape and reel	AM26LV31INS	26LV31I
			AM26LV31INSR	

(1) Package drawings, standard packing quantities, thermal data, symbolization, and PCB design guidelines are available at [www.ti.com/sc/package](http://www.ti.com/sc/package).



Please be aware that an important notice concerning availability, standard warranty, and use in critical applications of Texas Instruments semiconductor products and disclaimers thereto appears at the end of this data sheet.

LinIMPACT-C60 is a trademark of Texas Instruments.

# AM26LV31C, AM26LV31I LOW-VOLTAGE HIGH-SPEED QUADRUPLE DIFFERENTIAL LINE DRIVERS

SLLS201G—MAY 1995—REVISED MAY 2005

FUNCTION TABLE<sup>(1)</sup>

INPUT A	ENABLES		OUTPUTS	
	G	$\bar{G}$	Y	Z
H	H	X	H	L
L	H	X	L	H
H	X	L	H	L
L	X	L	L	H
X	L	H	Z	Z

(1) H = high level, L = low level, X = irrelevant,  
Z = high impedance (off)

LOGIC DIAGRAM (POSITIVE LOGIC)

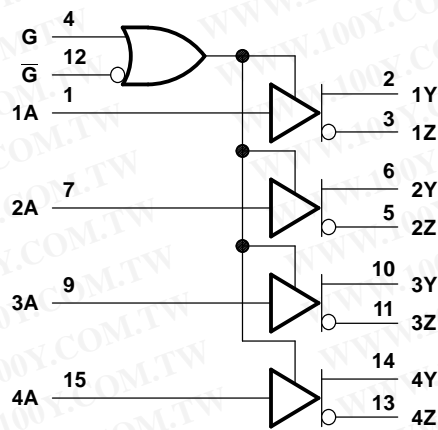

SCHEMATIC (EACH DRIVER)

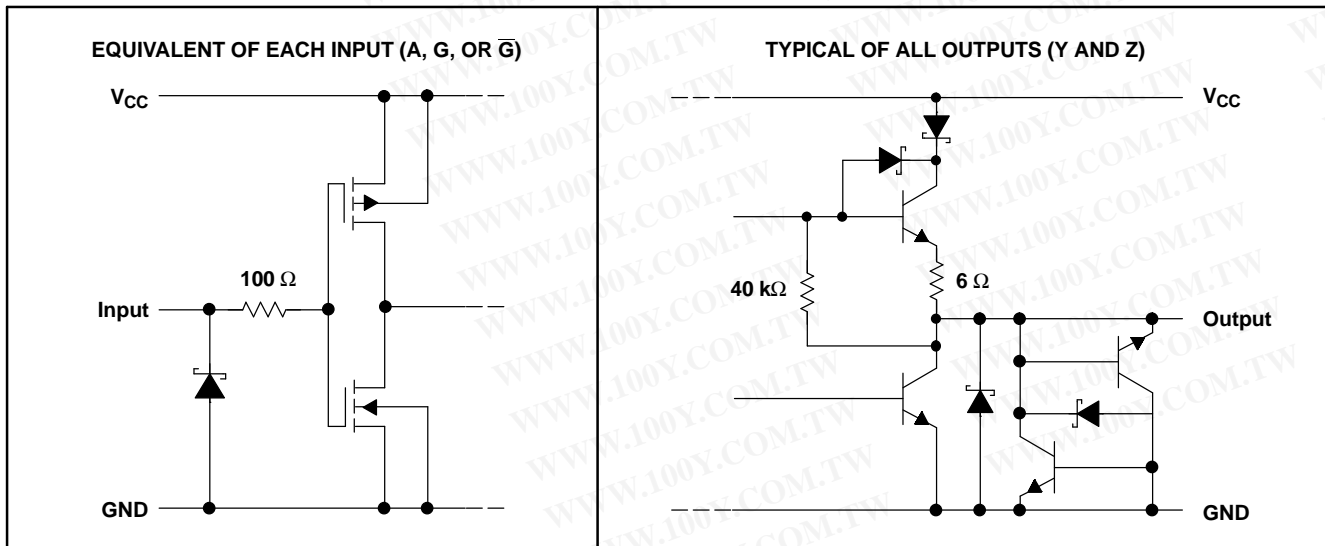

All resistor values are nominal.

勝特力材料 886-3-5753170  
 勝特力电子(上海) 86-21-54151736  
 勝特力电子(深圳) 86-755-83298787  
[Http://www.100y.com.tw](http://www.100y.com.tw)

**Absolute Maximum Ratings<sup>(1)</sup>**

over operating free-air temperature range (unless otherwise noted)

		MIN	MAX	UNIT
V <sub>CC</sub>	Supply voltage range <sup>(2)</sup>	-0.3	6	V
V <sub>I</sub>	Input voltage range	-0.3	6	V
V <sub>O</sub>	Output voltage range	-0.3	6	V
θ <sub>JA</sub>	Package thermal impedance <sup>(3)</sup>	D package		73
		NS package		64
	Lead temperature	1,6 mm (1/16 in) from case for 10 s		260
T <sub>stg</sub>	Storage temperature range	-65	150	°C

- (1) Stresses beyond those listed under "absolute maximum ratings" may cause permanent damage to the device. These are stress ratings only, and functional operation of the device at these or any other conditions beyond those indicated under "recommended operating conditions" is not implied. Exposure to absolute-maximum-rated conditions for extended periods may affect device reliability.
- (2) All voltage values are with respect to GND.
- (3) The package thermal impedance is calculated in accordance with JESD 51-7.

**Recommended Operating Conditions**

		MIN	NOM	MAX	UNIT
V <sub>CC</sub>	Supply voltage	3	3.3	3.6	V
V <sub>IH</sub>	High-level input voltage	2			V
V <sub>IL</sub>	Low-level input voltage			0.8	V
I <sub>OH</sub>	High-level output current			-30	mA
I <sub>OL</sub>	Low-level output current			30	mA
T <sub>A</sub>	Operating free-air temperature	AM26LV31C		0	70
		AM26LV31I		-45	85

**Electrical Characteristics**

over recommended operating supply-voltage and free-air temperature ranges (unless otherwise noted)

PARAMETER	TEST CONDITIONS	MIN	TYP <sup>(1)</sup>	MAX	UNIT
V <sub>IK</sub>	Input clamp voltage	I <sub>I</sub> = 18 mA		-1.5	V
V <sub>OH</sub>	High-level output voltage	V <sub>IH</sub> = 2 V,	I <sub>OH</sub> = -12 mA	1.85	2.3
V <sub>OL</sub>	Low-level output voltage	V <sub>IL</sub> = 0.8 V,	I <sub>OH</sub> = 12 mA	0.8	1.05
V <sub>OD</sub>	Differential output voltage <sup>(2)</sup>	R <sub>L</sub> = 100 Ω		0.95	1.5
V <sub>OC</sub>	Common-mode output voltage			1.3	1.55
Δ V <sub>OCl</sub>	Change in magnitude of common-mode output voltage <sup>(2)</sup>				±0.2
I <sub>O</sub>	Output current with power off	V <sub>O</sub> = -0.25 V or 6 V, V <sub>CC</sub> = 0			±100
I <sub>OZ</sub>	Off-state (high-impedance state) output current	V <sub>O</sub> = -0.25 V or 6 V, G = 0.8 V or $\bar{G}$ = 2 V			±100
I <sub>H</sub>	High-level input current	V <sub>CC</sub> = 0 or 3 V, V <sub>I</sub> = 5.5 V			10
I <sub>L</sub>	Low-level input current	V <sub>CC</sub> = 3.6 V, V <sub>I</sub> = 0			-10
I <sub>OS</sub>	Short-circuit output current	V <sub>CC</sub> = 3.6 V, V <sub>O</sub> = 0			-200
I <sub>CC</sub>	Supply current (all drivers)	V <sub>I</sub> = V <sub>CC</sub> or GND, No load			100
C <sub>pd</sub>	Power-dissipation capacitance (all drivers) <sup>(3)</sup>	No load			160

- (1) All typical values are at V<sub>CC</sub> = 3.3 V, T<sub>A</sub> = 25°C.
- (2) Δ|V<sub>OD</sub>| and Δ|V<sub>OCl</sub>| are the changes in magnitude of V<sub>OD</sub> and V<sub>OC</sub>, respectively, that occur when the input is changed from a high level to a low level.
- (3) C<sub>pd</sub> determines the no-load dynamic current consumption. I<sub>S</sub> = C<sub>pd</sub> × V<sub>CC</sub> × f + I<sub>CC</sub>

# AM26LV31C, AM26LV31I LOW-VOLTAGE HIGH-SPEED QUADRUPLE DIFFERENTIAL LINE DRIVERS

SLLS201G–MAY 1995–REVISED MAY 2005

## Switching Characteristics

$V_{CC} = 3.3\text{ V}$ ,  $T_A = 25^\circ\text{C}$

PARAMETER		TEST CONDITIONS	MIN	TYP <sup>(1)</sup>	MAX	UNIT
$t_{PLH}$	Propagation delay time, low- to high-level output	See Figure 2	4	8	12	ns
$t_{PHL}$	Propagation delay time, high- to low-level output		4	8	12	ns
$t_t$	Transition time ( $t_r$ or $t_f$ )			3		ns
SR	Slew rate, single-ended output voltage	See Note <sup>(2)</sup> and Figure 2		0.3	1	V/ns
$t_{PZH}$	Output-enable time to high level	See Figure 3		10	20	ns
$t_{PZL}$	Output-enable time to low level	See Figure 4		10	20	ns
$t_{PHZ}$	Output-disable time from high level	See Figure 3		10	20	ns
$t_{PLZ}$	Output-disable time from low level	See Figure 4		10	20	ns
$t_{sk(p)}$	Pulse skew	$f = 32\text{ MHz}$ , See Note <sup>(3)</sup>		0.5	1.5	ns
$t_{sk(o)}$	Skew limit	$f = 32\text{ MHz}$			1.5	ns
$t_{sk(lim)}$	Skew limit (device to device)	$f = 32\text{ MHz}$ , See Note <sup>(4)</sup>			3	ns

(1) All typical values are at  $V_{CC} = 3.3\text{ V}$ ,  $T_A = 25^\circ\text{C}$ .

(2) Slew rate is defined by:

$$SR = \frac{90\%(V_{OH} - V_{OL}) - 10\%(V_{OH} - V_{OL})}{t_r}, \text{ the differential slew rate of } V_{OD} \text{ is } 2 \times SR.$$

(3) Pulse skew is defined as the  $|t_{PLH} - t_{PHL}|$  of each channel of the same device.

(4) Skew limit (device to device) is the maximum difference in propagation delay times between any two channels of any two devices.

勝特力材料 886-3-5753170  
 胜特力电子(上海) 86-21-54151736  
 胜特力电子(深圳) 86-755-83298787  
 Http://www.100y.com.tw

PARAMETER MEASUREMENT INFORMATION

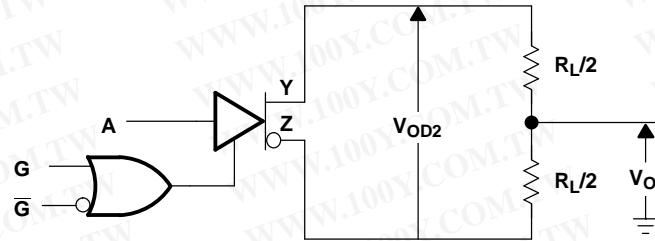
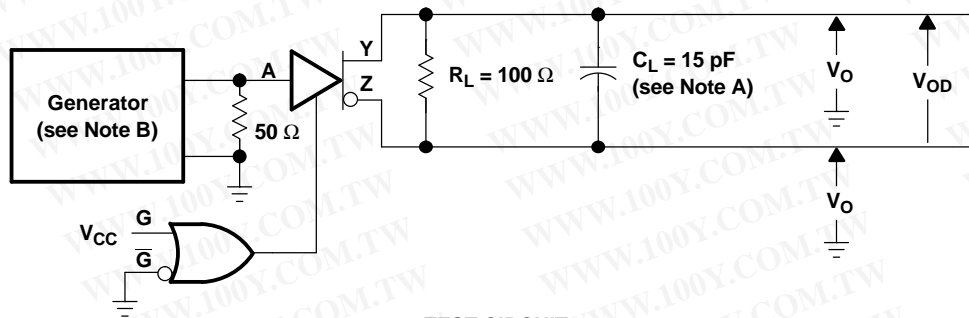
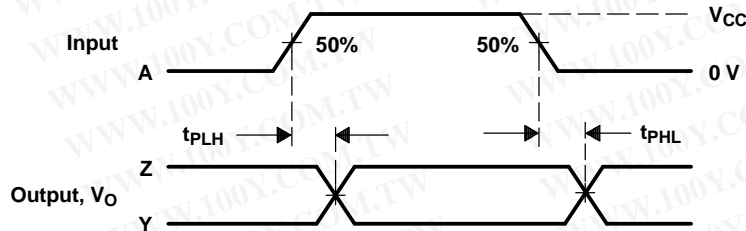

Figure 1. Differential and Common-Mode Output Voltages



TEST CIRCUIT



PROPAGATION DELAY TIMES

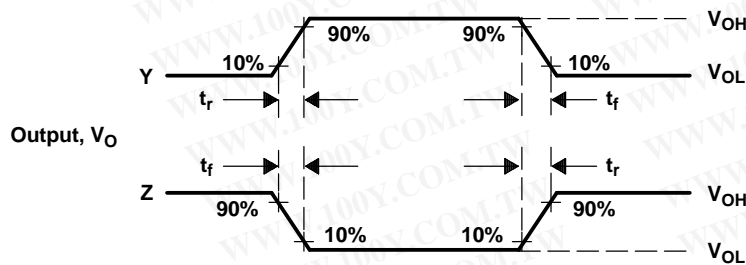

RISE AND FALL TIMES

- NOTES: A.  $C_L$  includes probe and jig capacitance.  
B. The input pulse is supplied by a generator having the following characteristics: PRR = 32 MHz,  $Z_0 = 50 \Omega$ , 50% duty cycle,  $t_r$  and  $t_f \leq 2$  ns.

Figure 2. Test Circuit and Voltage Waveforms,  $t_{PHL}$  and  $t_{PLH}$

勝特力材料 886-3-5753170  
勝特力电子(上海) 86-21-54151736  
勝特力电子(深圳) 86-755-83298787  
[Http://www.100y.com.tw](http://www.100y.com.tw)

PARAMETER MEASUREMENT INFORMATION

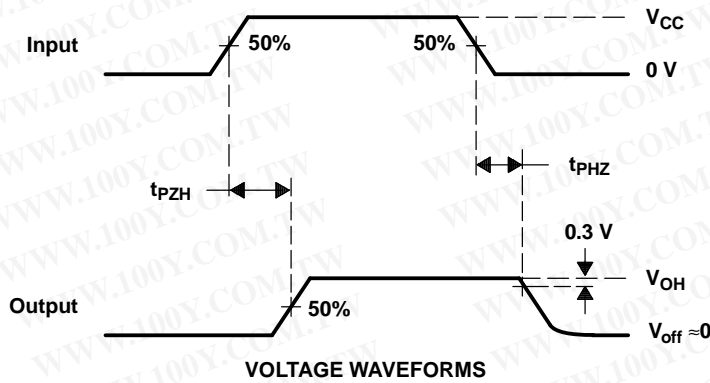
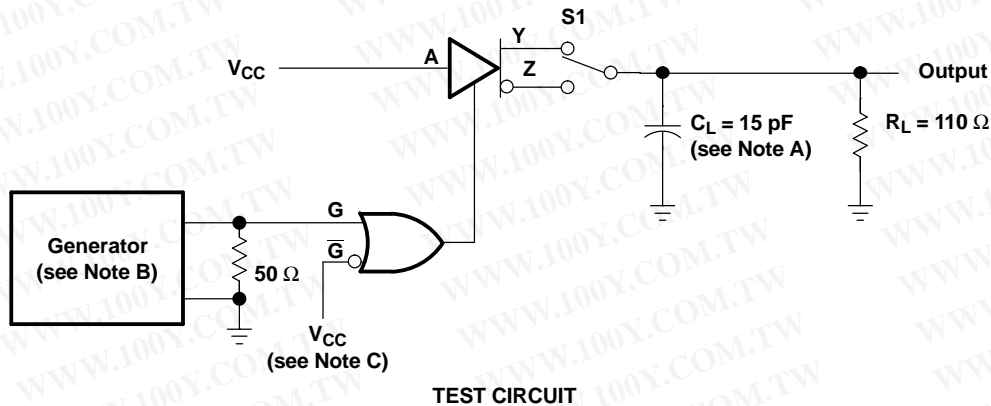

- NOTES: A.  $C_L$  includes probe and jig capacitance.  
 B. The input pulse is supplied by a generator having the following characteristics: PRR = 1 MHz,  $Z_O = 50 \Omega$ , 50% duty cycle,  $t_r$  and  $t_f$  (10% to 90%)  $\leq 2$  ns.  
 C. To test the active-low enable  $\bar{G}$ , ground G and apply an inverted waveform to  $\bar{G}$ .

Figure 3. Test Circuit and Voltage Waveforms,  $t_{PZH}$  and  $t_{PHZ}$

勝特力材料 886-3-5753170  
 勝特力电子(上海) 86-21-54151736  
 勝特力电子(深圳) 86-755-83298787  
 Http://www.100y.com.tw

PARAMETER MEASUREMENT INFORMATION

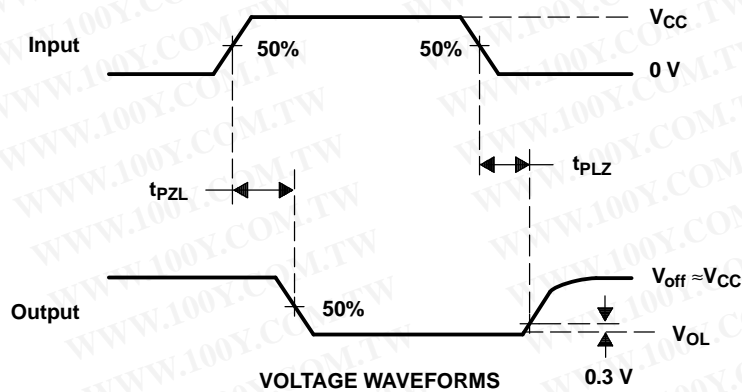
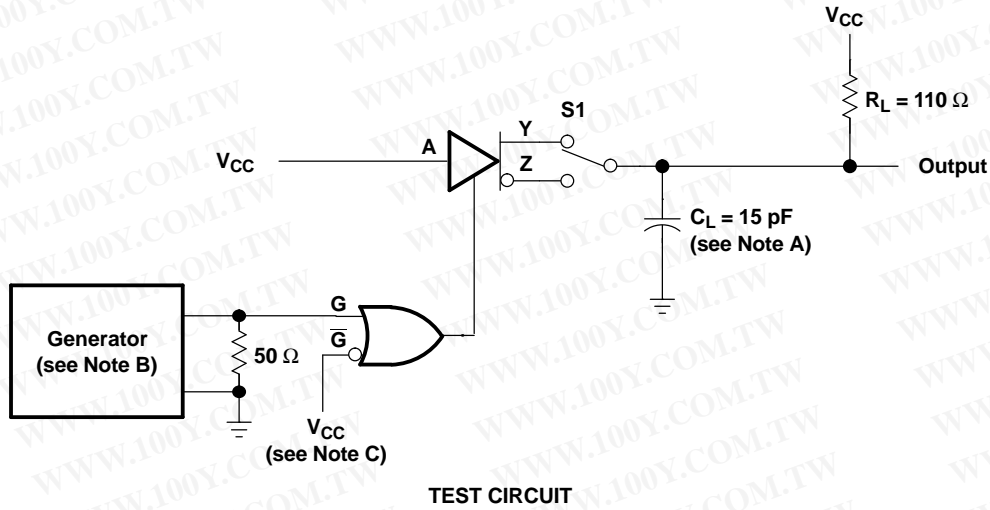

- NOTES: A.  $C_L$  includes probe and jig capacitance.  
 B. The input pulse is supplied by a generator having the following characteristics: PRR = 1 MHz,  $Z_O = 50 \Omega$ , 50% duty cycle,  $t_r$  and  $t_f$  (10% to 90%)  $\leq 2$  ns.  
 C. To test the active-low enable  $\bar{G}$ , ground G and apply an inverted waveform to  $\bar{G}$ .

Figure 4. Test Circuit and Voltage Waveforms,  $t_{PZL}$  and  $t_{PLZ}$

勝特力材料 886-3-5753170  
 勝特力电子(上海) 86-21-54151736  
 勝特力电子(深圳) 86-755-83298787  
[Http://www.100y.com.tw](http://www.100y.com.tw)

PACKAGING INFORMATION

Orderable Device	Status <sup>(1)</sup>	Package Type	Package Drawing	Pins	Package Qty	Eco Plan <sup>(2)</sup>	Lead/Ball Finish	MSL Peak Temp <sup>(3)</sup>
AM26LV31CD	ACTIVE	SOIC	D	16	40	Green (RoHS & no Sb/Br)	CU NIPDAU	Level-1-260C-UNLIM
AM26LV31CDE4	ACTIVE	SOIC	D	16	40	Green (RoHS & no Sb/Br)	CU NIPDAU	Level-1-260C-UNLIM
AM26LV31CDR	ACTIVE	SOIC	D	16	2500	Green (RoHS & no Sb/Br)	CU NIPDAU	Level-1-260C-UNLIM
AM26LV31CDRE4	ACTIVE	SOIC	D	16	2500	Green (RoHS & no Sb/Br)	CU NIPDAU	Level-1-260C-UNLIM
AM26LV31CNSLE	OBSOLETE	SO	NS	16		TBD	Call TI	Call TI
AM26LV31CNSR	ACTIVE	SO	NS	16	2000	Green (RoHS & no Sb/Br)	CU NIPDAU	Level-1-260C-UNLIM
AM26LV31CNSRE4	ACTIVE	SO	NS	16	2000	Green (RoHS & no Sb/Br)	CU NIPDAU	Level-1-260C-UNLIM
AM26LV31ID	ACTIVE	SOIC	D	16	40	Green (RoHS & no Sb/Br)	CU NIPDAU	Level-1-260C-UNLIM
AM26LV31IDE4	ACTIVE	SOIC	D	16	40	Green (RoHS & no Sb/Br)	CU NIPDAU	Level-1-260C-UNLIM
AM26LV31IDR	ACTIVE	SOIC	D	16	2500	Green (RoHS & no Sb/Br)	CU NIPDAU	Level-1-260C-UNLIM
AM26LV31IDRE4	ACTIVE	SOIC	D	16	2500	Green (RoHS & no Sb/Br)	CU NIPDAU	Level-1-260C-UNLIM
AM26LV31INSR	ACTIVE	SO	NS	16	2000	Green (RoHS & no Sb/Br)	CU NIPDAU	Level-1-260C-UNLIM
AM26LV31INSRE4	ACTIVE	SO	NS	16	2000	Green (RoHS & no Sb/Br)	CU NIPDAU	Level-1-260C-UNLIM

<sup>(1)</sup> The marketing status values are defined as follows:

**ACTIVE:** Product device recommended for new designs.

**LIFEBUY:** TI has announced that the device will be discontinued, and a lifetime-buy period is in effect.

**NRND:** Not recommended for new designs. Device is in production to support existing customers, but TI does not recommend using this part in a new design.

**PREVIEW:** Device has been announced but is not in production. Samples may or may not be available.

**OBSOLETE:** TI has discontinued the production of the device.

<sup>(2)</sup> Eco Plan - The planned eco-friendly classification: Pb-Free (RoHS), Pb-Free (RoHS Exempt), or Green (RoHS & no Sb/Br) - please check <http://www.ti.com/productcontent> for the latest availability information and additional product content details.

**TBD:** The Pb-Free/Green conversion plan has not been defined.

**Pb-Free (RoHS):** TI's terms "Lead-Free" or "Pb-Free" mean semiconductor products that are compatible with the current RoHS requirements for all 6 substances, including the requirement that lead not exceed 0.1% by weight in homogeneous materials. Where designed to be soldered at high temperatures, TI Pb-Free products are suitable for use in specified lead-free processes.

**Pb-Free (RoHS Exempt):** This component has a RoHS exemption for either 1) lead-based flip-chip solder bumps used between the die and package, or 2) lead-based die adhesive used between the die and leadframe. The component is otherwise considered Pb-Free (RoHS compatible) as defined above.

**Green (RoHS & no Sb/Br):** TI defines "Green" to mean Pb-Free (RoHS compatible), and free of Bromine (Br) and Antimony (Sb) based flame retardants (Br or Sb do not exceed 0.1% by weight in homogeneous material)

<sup>(3)</sup> MSL, Peak Temp. -- The Moisture Sensitivity Level rating according to the JEDEC industry standard classifications, and peak solder temperature.

**Important Information and Disclaimer:** The information provided on this page represents TI's knowledge and belief as of the date that it is provided. TI bases its knowledge and belief on information provided by third parties, and makes no representation or warranty as to the accuracy of such information. Efforts are underway to better integrate information from third parties. TI has taken and continues to take reasonable steps to provide representative and accurate information but may not have conducted destructive testing or chemical analysis on incoming materials and chemicals. TI and TI suppliers consider certain information to be proprietary, and thus CAS numbers and other limited



information may not be available for release.

In no event shall TI's liability arising out of such information exceed the total purchase price of the TI part(s) at issue in this document sold by TI to Customer on an annual basis.

勝特力材料 886-3-5753170  
勝特力电子(上海) 86-21-54151736  
勝特力电子(深圳) 86-755-83298787  
[Http://www.100y.com.tw](http://www.100y.com.tw)

D (R-PDSO-G16)

PLASTIC SMALL-OUTLINE PACKAGE

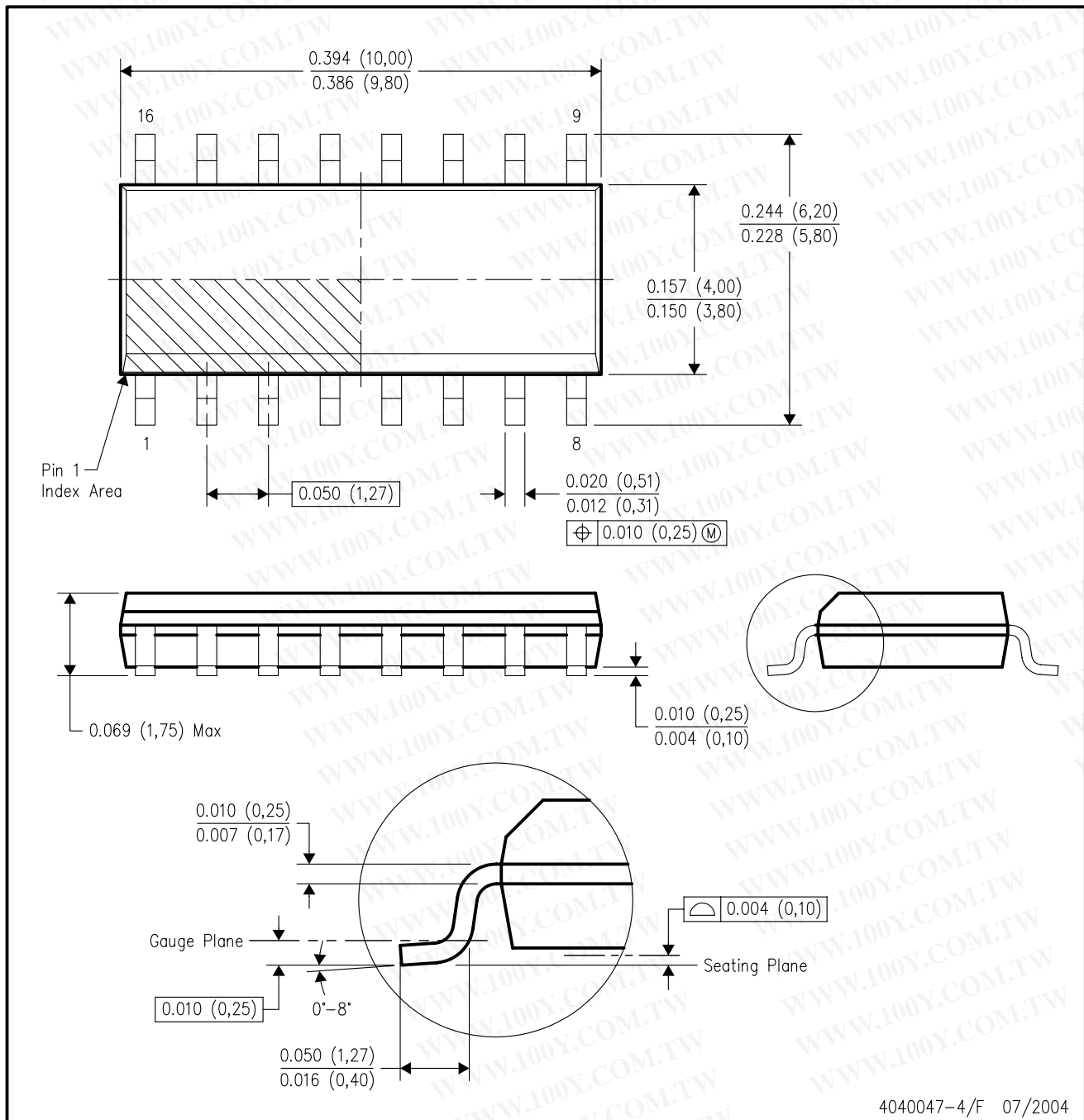

4040047-4/F 07/2004

- NOTES:
- All linear dimensions are in inches (millimeters).
  - This drawing is subject to change without notice.
  - Body dimensions do not include mold flash or protrusion not to exceed 0.006 (0,15).
  - Falls within JEDEC MS-012 variation AC.

MECHANICAL DATA

NS (R-PDSO-G\*\*)

PLASTIC SMALL-OUTLINE PACKAGE

14-PINS SHOWN

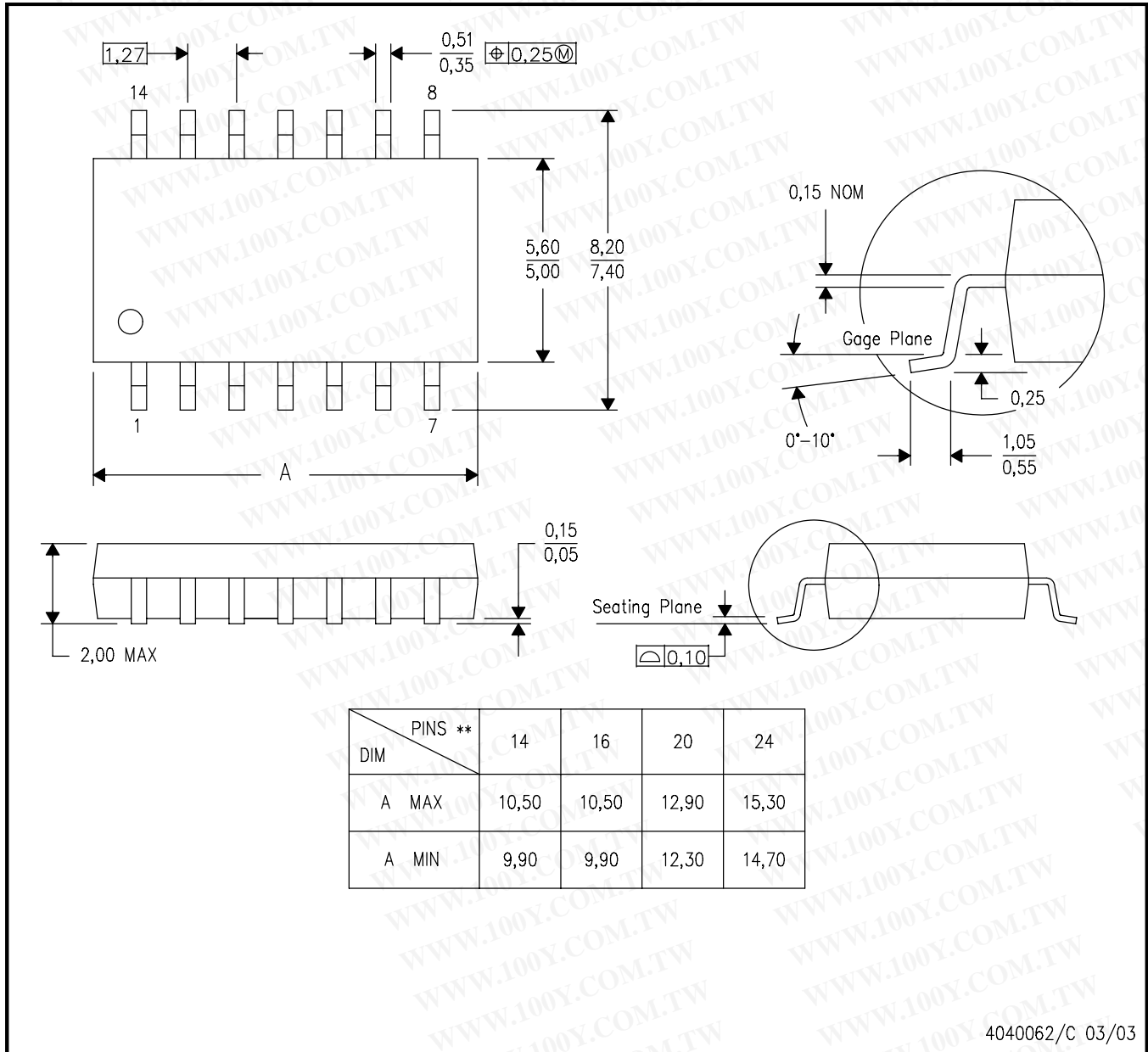

- NOTES:
- A. All linear dimensions are in millimeters.
  - B. This drawing is subject to change without notice.
  - C. Body dimensions do not include mold flash or protrusion, not to exceed 0,15.