

SN54251, SN54LS251 SN54S251, SN74251, SN74LS251, (TIM9905), SN74S251 DATA SELECTORS/MULTIPLEXERS WITH 3-STATE OUTPUTS

SDLS085 - DECEMBER 1972 - REVISED MARCH 1988

- Three-State Versions of '151, 'LS151, 'S151
- Three-State Outputs Interface Directly with System Bus
- Perform Parallel-to-Serial Conversion
- Permit Multiplexing from N-lines to One Line
- Complementary Outputs Provide True and Inverted Data
- Fully Compatible with Most TTL Circuits

SN54251, SN54LS251, SN54S251 . . . J OR W PACKAGE
SN74251 . . . N PACKAGE
SN74LS251, SN74S251 . . . D OR N PACKAGE

(TOP VIEW)

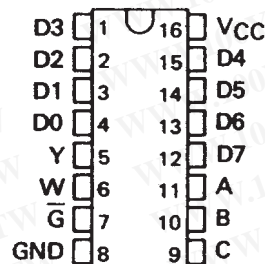

TYPE	MAX NO. OF COMMON OUTPUTS	TYPICAL AVG PROP DELAY TIME (D TO Y)	TYPICAL POWER DISSIPATION
SN54251	49	17 ns	250 mW
SN74251	129	17 ns	250 mW
SN54LS251	49	17 ns	35 mW
SN74LS251	129	17 ns	35 mW
SN54S251	39	8 ns	275 mW
SN74S251	129	8 ns	275 mW

description

These monolithic data selectors/multiplexers contain full on-chip binary decoding to select one-of-eight data sources and feature a strobe-controlled three-state output. The strobe must be at a low logic level to enable these devices. The three-state outputs permit a number of outputs to be connected to a common bus. When the strobe input is high, both outputs are in a high-impedance state in which both the upper and lower transistors of each totem-pole output are off, and the output neither drives nor loads the bus significantly. When the strobe is low, the outputs are activated and operate as standard TTL totem-pole outputs.

To minimize the possibility that two outputs will attempt to take a common bus to opposite logic levels, the output control circuitry is designed so that the average output disable time is shorter than the average output enable time. The SN54251 and SN74251 have output clamp diodes to attenuate reflections on the bus line.

SN54LS251, SN54S251 . . . FK PACKAGE
(TOP VIEW)

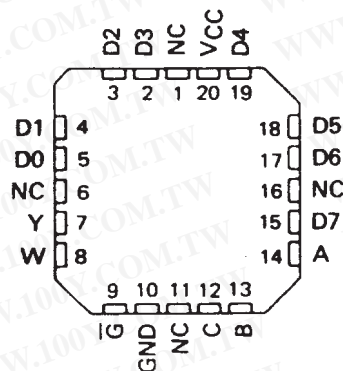

NC - No internal connection

FUNCTION TABLE

INPUTS			OUTPUTS		
SELECT	ENABLE		Y	W	
C	B	A	\bar{Y}	\bar{W}	
X	X	X	H	Z	Z
L	L	L	L	D0	$\bar{D0}$
L	L	H	L	D1	$\bar{D1}$
L	H	L	L	D2	$\bar{D2}$
L	H	H	L	D3	$\bar{D3}$
H	L	L	L	D4	$\bar{D4}$
H	L	H	L	D5	$\bar{D5}$
H	H	L	L	D6	$\bar{D6}$
H	H	H	L	D7	$\bar{D7}$

H = high logic level, L = low logic level

X = irrelevant, Z = high impedance (off)

D0, D1 . . . D7 = the level of the respective D input

勝特力材料 886-3-5753170
勝特力电子(上海) 86-21-54151736
勝特力电子(深圳) 86-755-83298787
[Http://www.100y.com.tw](http://www.100y.com.tw)

**SN54251, SN54LS251 SN54S251,
SN74251, SN74LS251, (TIM9905), SN74S251
DATA SELECTORS/MULTIPLEXERS WITH 3-STATE OUTPUTS**

SDLS085 - DECEMBER 1972 - REVISED MARCH 1988

logic diagram (positive logic)

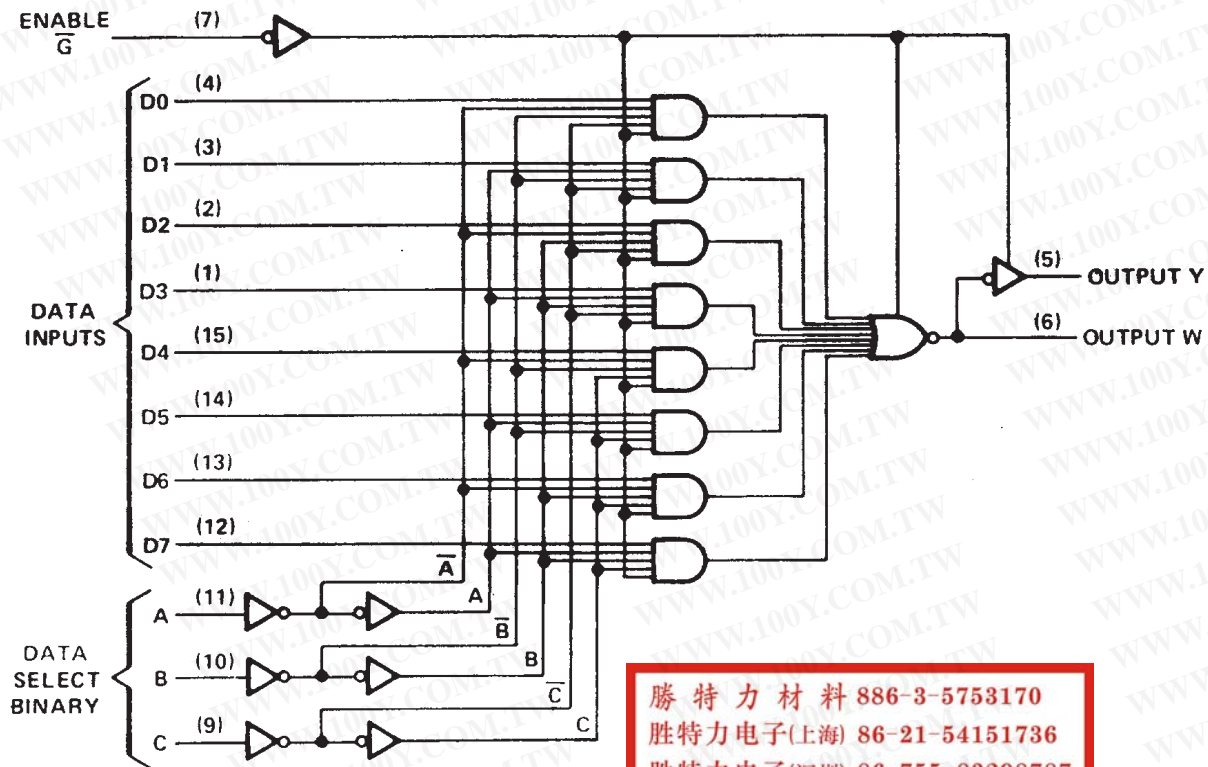

勝特力材料 886-3-5753170
 勝特力电子(上海) 86-21-54151736
 勝特力电子(深圳) 86-755-83298787
[Http://www.100y.com.tw](http://www.100y.com.tw)

logic symbol†

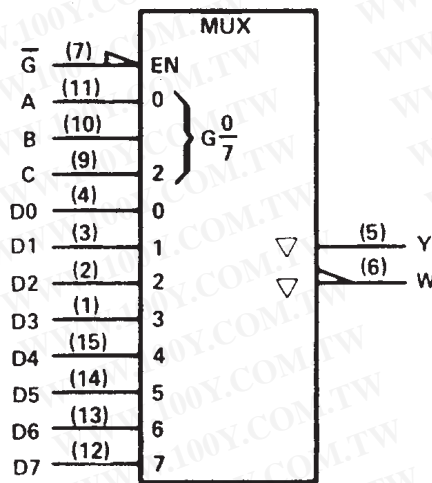

†This symbol is in accordance with ANSI/IEEE Std. 91-1984 and IEC Publication 617-12. Pin numbers shown are for D, J, N, and W packages.

SN54251 SN74251, DATA SELECTORS/MULTIPLEXERS WITH 3-STATE OUTPUTS

SDLS085 – DECEMBER 1972 – REVISED MARCH 1988

absolute maximum ratings over operating free-air temperature range (unless otherwise noted)

Supply voltage, V_{CC} (see Note 1)		7 V
Input voltage		5.5 V
Off-state output voltage		5.5 V
Operating free-air temperature range: SN54251		–55°C to 125°C
SN74251		0°C to 70°C
Storage temperature range		–65°C to 150°C

勝特力材料 886-3-5753170
 勝特力电子(上海) 86-21-54151736
 勝特力电子(深圳) 86-755-83298787
[Http://www.100y.com.tw](http://www.100y.com.tw)

NOTE 1: Voltage values are with respect to network ground terminal.

recommended operating conditions

	SN54251			SN74251			UNIT
	MIN	NOM	MAX	MIN	NOM	MAX	
Supply voltage, V_{CC}	4.5	5	5.5	4.75	5	5.25	V
High-level output current, I_{OH}			–2			–5.2	mA
Low-level output current, I_{OL}			16			16	mA
Operating free-air temperature, T_A	–55		125	0		70	°C

electrical characteristics over recommended operating free-air temperature range (unless otherwise noted)

PARAMETER		TEST CONDITIONS†	MIN	TYP‡	MAX	UNIT
V_{IH}	High-level input voltage		2			V
V_{IL}	Low-level input voltage				0.8	V
V_{IK}	Input clamp voltage	$V_{CC} = \text{MIN}, I_I = -12 \text{ mA}$			–1.5	V
V_{OH}	High-level output voltage	$V_{CC} = \text{MIN}, V_{IH} = 2 \text{ V}, V_{IL} = 0.8 \text{ V}, I_{OH} = \text{MAX}$	2.4	3.2		V
V_{OL}	Low-level output voltage	$V_{CC} = \text{MIN}, V_{IH} = 2 \text{ V}, V_{IL} = 0.8 \text{ V}, I_{OL} = 16 \text{ mA}$		0.2	0.4	V
I_{OZ}	Off-state (high-impedance-state) output current	$V_{CC} = \text{MAX}, V_{IH} = 2 \text{ V}$	$V_O = 2.4 \text{ V}$		40	μA
			$V_O = 0.4 \text{ V}$		–40	
V_O	Output clamp voltage	$V_{CC} = \text{MAX}, V_{IH} = 4.5 \text{ V}$	$I_O = -12 \text{ mA}$		–1.5	V
			$I_O = 12 \text{ mA}$		$V_{CC} + 1.5$	
I_I	Input current at maximum input voltage	$V_{CC} = \text{MAX}, V_I = 5.5 \text{ V}$			1	mA
I_{IH}	High-level input current	$V_{CC} = \text{MAX}, V_I = 2.4 \text{ V}$			40	μA
I_{IL}	Low-level input current	$V_{CC} = \text{MAX}, V_I = 0.4 \text{ V}$			–1.6	mA
I_{OS}	Short-circuit output current §	$V_{CC} = \text{MAX}$	–18		–55	mA
I_{CC}	Supply current	$V_{CC} = \text{MAX},$ All inputs at 4.5 V, All outputs open		38	62	mA

† For conditions shown as MIN or MAX, use the appropriate value specified under recommended operating conditions for the applicable type.

‡ All typical values are at $V_{CC} = 5 \text{ V}, T_A = 25^\circ\text{C}$.

§ Not more than one output should be shorted at a time.



SN54251 SN74251, DATA SELECTORS/MULTIPLEXERS WITH 3-STATE OUTPUTS

SDLS085 – DECEMBER 1972 – REVISED MARCH 1988

switching characteristics, $V_{CC} = 5\text{ V}$, $T_A = 25^\circ\text{C}$

PARAMETER†	FROM (INPUT)	TO (OUTPUT)	TEST CONDITIONS	MIN	TYP	MAX	UNIT
t_{PLH}	A, B, or C (4 levels)	Y	$C_L = 50\text{ pF}$, $R_L = 400\ \Omega$, See Note 2	29	45	ns	
t_{PHL}				28	45		
t_{PLH}	A, B, or C (3 levels)	W		20	33	ns	
t_{PHL}				21	33		
t_{PLH}	Any D	Y		17	28	ns	
t_{PHL}				18	28		
t_{PLH}	Any D	W		10	15	ns	
t_{PHL}				9	15		
t_{PZH}	\bar{G}	Y		17	27	ns	
t_{PZL}				26	40		
t_{PZH}	\bar{G}	W	17	27	ns		
t_{PZL}			24	40			
t_{PHZ}	\bar{G}	Y	$C_L = 5\text{ pF}$, $R_L = 400\ \Omega$, See Note 2	5	8	ns	
t_{PLZ}				15	23		
t_{PHZ}	\bar{G}	W		5	8	ns	
t_{PLZ}				15	23		

- † t_{PLH} = Propagation delay time, low-to-high-level output
- t_{PHL} = Propagation delay time, high-to-low-level output
- t_{PZH} = Output enable time to high level
- t_{PZL} = Output enable time to low level
- t_{PHZ} = Output disable time from high level
- t_{PLZ} = Output disable time from low level

NOTE 2: Load circuits and voltage waveforms are shown in Section 1.

勝特力材料 886-3-5753170
勝特力电子(上海) 86-21-54151736
勝特力电子(深圳) 86-755-83298787
[Http://www.100y.com.tw](http://www.100y.com.tw)

schematics of inputs and outputs

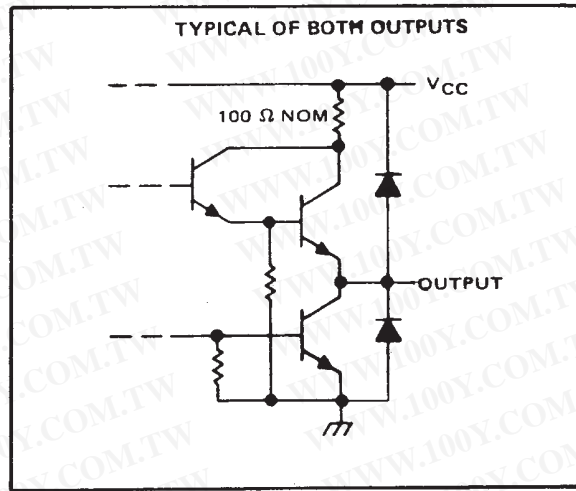
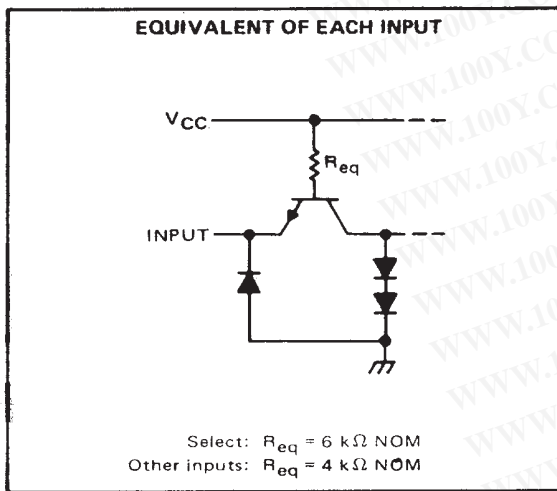

SN54LS251 SN74LS251, DATA SELECTORS/MULTIPLEXERS WITH 3-STATE OUTPUTS

SDLS085 – DECEMBER 1972 – REVISED MARCH 1988

absolute maximum ratings over operating free-air temperature range (unless otherwise noted)

Supply voltage, V_{CC} (see Note 1)	7 V
Input voltage	7 V
Off-state output voltage	5.5 V
Operating free-air temperature range: SN54LS251	55°C to 125°C
SN74LS251	0°C to 70°C
Storage temperature range	-65°C to 150°C

勝特力材料 886-3-5753170
勝特力电子(上海) 86-21-54151736
勝特力电子(深圳) 86-755-83298787
[Http://www.100y.com.tw](http://www.100y.com.tw)

NOTE 1: Voltage values are with respect to network ground terminal.

recommended operating conditions

	SN54LS251			SN74LS251			UNIT
	MIN	NOM	MAX	MIN	NOM	MAX	
V_{CC} Supply voltage	4.5	5	5.5	4.75	5	5.25	V
V_{IH} High-level input voltage	2			2			V
V_{IL} Low-level input voltage			0.7			0.8	V
I_{OH} High-level output current			-1			-2.6	mA
I_{OL} Low-level output current			4			8	mA
T_A Operating free-air temperature	-55		125	0		70	°C

electrical characteristics over recommended operating free-air temperature range (unless otherwise noted)

PARAMETER	TEST CONDITIONS†	SN54LS251			SN74LS251			UNIT
		MIN	TYP ‡	MAX	MIN	TYP ‡	MAX	
V_{IK}	$V_{CC} = \text{MIN}, I_I = -18 \text{ mA}$			-1.5			-1.5	V
V_{OH}	$V_{CC} = \text{MIN}, V_{IH} = 2 \text{ V}, V_{IL} = \text{MAX}, I_{OH} = \text{MAX}$	2.4	3.4		2.4	3.1		V
V_{OL}	$V_{CC} = \text{MIN}, V_{IH} = 2 \text{ V}, V_{IL} = \text{MAX}$	$I_{OL} = 4 \text{ mA}$		0.25	0.4	$I_{OL} = 4 \text{ mA}$		V
		$I_{OL} = 8 \text{ mA}$				$I_{OL} = 8 \text{ mA}$		
I_{OZ}	$V_{CC} = \text{MAX}, V_{IH} = 2 \text{ V}$	$V_O = 2.7 \text{ V}$				$V_O = 2.7 \text{ V}$		μA
		$V_O = 0.4 \text{ V}$				$V_O = 0.4 \text{ V}$		
I_I	$V_{CC} = \text{MAX}, V_I = 7 \text{ V}$			0.1			0.1	mA
I_{IH}	$V_{CC} = \text{MAX}, V_I = 2.7 \text{ V}$			20			20	μA
I_{IL}	Enable \bar{C} All other	$V_{CC} = \text{MAX}, V_I = 0.4$				-0.2	-0.2	mA
						-0.4	-0.4	
$I_{OS}§$	$V_{CC} = \text{MAX}$	-30	-130			-30	-130	mA
I_{CC}	$V_{CC} = \text{MAX},$ See Note 3	Condition A		6.1	10	Condition A		mA
		Condition B		7.1	12	Condition B		

† For conditions shown as MIN or MAX, use the appropriate value specified under recommended operating conditions for the applicable type.

‡ All typical values are at $V_{CC} = 5 \text{ V}, T_A = 25^\circ\text{C}$.

§ Not more than one output should be shorted at a time, and duration of the short-circuit should not exceed one second.

NOTE 3: I_{CC} is measured with the outputs open and all data and select inputs at 4.5 V under the following conditions:

- A. Enable grounded.
- B. Strobe at 4.5 V.



SN54LS251 SN74LS251, (TIM9905), DATA SELECTORS/MULTIPLEXERS WITH 3-STATE OUTPUTS

SDLS085 – DECEMBER 1972 – REVISED MARCH 1988

switching characteristics, $V_{CC} = 5\text{ V}$, $T_A = 25^\circ\text{C}$

PARAMETER†	FROM (INPUT)	TO (OUTPUT)	TEST CONDITIONS	MIN	TYP	MAX	UNIT
t_{PLH}	A, B, or C (4 levels)	Y	$C_L = 15\text{ pF}$, $R_L = 2\text{ k}\Omega$, See Note 2		29	45	ns
t_{PHL}					28	45	
t_{PLH}	A, B, or C (3 levels)	W			20	33	ns
t_{PHL}					21	33	
t_{PLH}	Any D	Y			17	28	ns
t_{PHL}					18	28	
t_{PLH}	Any D	W			10	15	ns
t_{PHL}					9	15	
t_{PZH}	\bar{G}	Y			30	45	ns
t_{PZL}					26	40	
t_{PZH}	\bar{G}	W			17	27	ns
t_{PZL}					24	40	
t_{PHZ}	\bar{G}	Y	$C_L = 5\text{ pF}$, $R_L = 2\text{ k}\Omega$, See Note 2		30	45	ns
t_{PLZ}					15	25	
t_{PHZ}	\bar{G}	W			37	55	ns
t_{PLZ}					15	25	

† t_{PLH} = Propagation delay time, low-to-high-level output
 t_{PHL} = Propagation delay time, high-to-low-level output
 t_{PZH} = Output enable time to high level
 t_{PZL} = Output enable time to low level
 t_{PHZ} = Output disable time from high level
 t_{PLZ} = Output disable time from low level
 NOTE 2: Load circuits and voltage waveforms are shown in Section 1.

勝特力材料 886-3-5753170
勝特力电子(上海) 86-21-54151736
勝特力电子(深圳) 86-755-83298787
[Http://www.100y.com.tw](http://www.100y.com.tw)

schematics of inputs and outputs

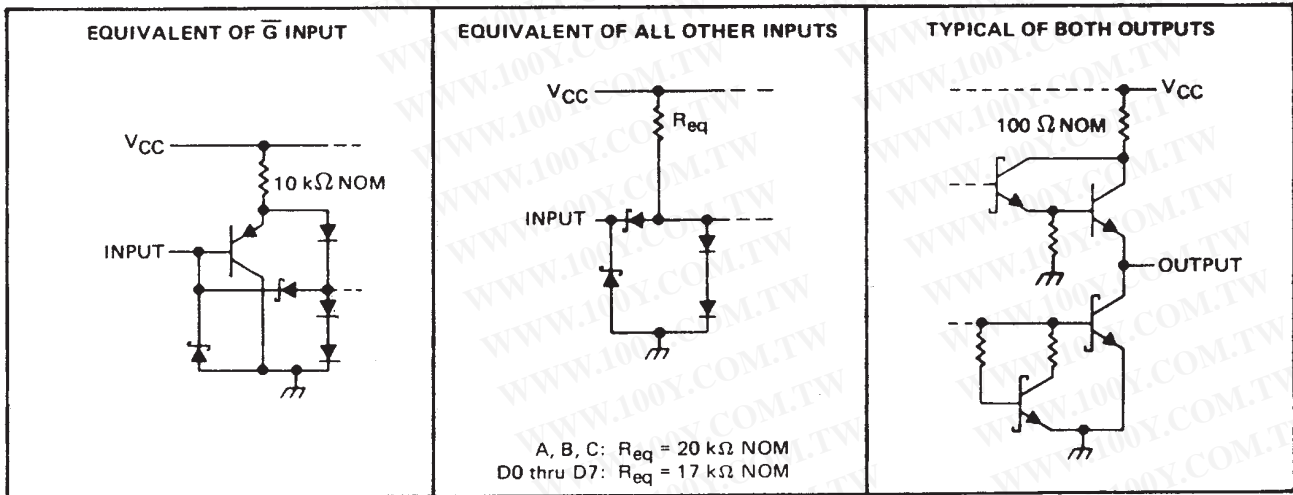

SN54S251 SN74S251, DATA SELECTORS/MULTIPLEXERS WITH 3-STATE OUTPUTS

SDLS085 – DECEMBER 1972 – REVISED MARCH 1988

absolute maximum ratings over operating free-air temperature range (unless otherwise noted)

Supply voltage, V_{CC} (see Note 1)	7 V	
Input voltage	5.5 V	
Off-state output voltage	5.5 V	
Operating free-air temperature range: SN54S251	–55°C to 125°C	
SN74S251	0°C to 70°C	
Storage temperature range	–65°C to 150°C	

勝特力材料 886-3-5753170
勝特力电子(上海) 86-21-54151736
勝特力电子(深圳) 86-755-83298787
[Http://www.100y.com.tw](http://www.100y.com.tw)

NOTE 1: Voltage values are with respect to network ground terminal.

recommended operating conditions

	SN54S251			SN74S251			UNIT
	MIN	NOM	MAX	MIN	NOM	MAX	
Supply voltage, V_{CC}	4.5	5	5.5	4.75	5	5.25	V
High-level output current, I_{OH}			–2			–6.5	mA
Low-level output current, I_{OL}			20			20	mA
Operating free-air temperature, T_A	–55		125	0		70	°C

electrical characteristics over recommended operating free-air temperature range (unless otherwise noted)

PARAMETER	TEST CONDITIONS†	MIN	TYP‡	MAX	UNIT
V_{IH} High-level input voltage		2			V
V_{IL} Low-level input voltage				0.8	V
V_{IK} Input clamp voltage	$V_{CC} = \text{MIN}, I_I = -18 \text{ mA}$			–1.2	V
V_{OH} High-level output voltage	$V_{CC} = \text{MIN}, V_{IH} = 2 \text{ V}, V_{IL} = 0.8 \text{ V}, I_{OH} = \text{MAX}$	SN54S'	2.4	3.4	V
		SN74S'	2.4	3.2	
V_{OL} Low-level output voltage	$V_{CC} = \text{MIN}, V_{IH} = 2 \text{ V}, V_{IL} = 0.8 \text{ V}, I_{OL} = 20 \text{ mA}$			0.5	V
I_{OZ} Off-state (high-impedance-state) output current	$V_{CC} = \text{MAX}, V_{IH} = 2 \text{ V}$	$V_O = 2.4 \text{ V}$		50	μA
		$V_O = 0.5 \text{ V}$		–50	
I_I Input current at maximum input voltage	$V_{CC} = \text{MAX}, V_I = 5.5 \text{ V}$			1	mA
I_{IH} High-level input current	$V_{CC} = \text{MAX}, V_I = 2.7 \text{ V}$			50	μA
I_{IL} Low-level input current	$V_{CC} = \text{MAX}, V_I = 0.5 \text{ V}$			–2	mA
I_{OS} Short-circuit output current §	$V_{CC} = \text{MAX}$	–40		–100	mA
I_{CC} Supply current	$V_{CC} = \text{MAX},$ All inputs at 4.5 V, All outputs open		55	85	mA

† For conditions shown as MIN or MAX, use the appropriate value specified under recommended operating conditions for the applicable type.

‡ All typical values are at $V_{CC} = 5 \text{ V}, T_A = 25^\circ\text{C}$.

§ Not more than one output should be shorted at a time, and duration of the short-circuit should not exceed one second.



SN54S251 SN74S251, DATA SELECTORS/MULTIPLEXERS WITH 3-STATE OUTPUTS

SDLS085 – DECEMBER 1972 – REVISED MARCH 1988

switching characteristics, $V_{CC} = 5\text{ V}$, $T_A = 25^\circ\text{C}$

PARAMETER†	FROM (INPUT)	TO (OUTPUT)	TEST CONDITIONS	MIN	TYP	MAX	UNIT
t_{PLH}	A, B, or C (4 levels)	Y	$C_L = 15\text{ pF}$, $R_L = 280\ \Omega$, See Note 2	12	18	ns	
t_{PHL}				13	19.5		
t_{PLH}	A, B, or C (3 levels)	W		10	15	ns	
t_{PHL}				9	13.5		
t_{PLH}	Any D	Y		8	12	ns	
t_{PHL}				8	12		
t_{PLH}	Any D	W		4.5	7	ns	
t_{PHL}				4.5	7		
t_{PZH}	\bar{G}	Y		$C_L = 50\text{ pF}$, $R_L = 280\ \Omega$, See Note 2	13	19.5	ns
t_{PZL}					14	21	
t_{PZH}	\bar{G}	W	13		19.5	ns	
t_{PZL}			14		21		
t_{PHZ}	\bar{G}	Y	5.5		8.5	ns	
t_{PLZ}			9		14		
t_{PHZ}	\bar{G}	W	See Note 2	5.5	8.5	ns	
t_{PLZ}				9	14		

- † t_{PLH} = Propagation delay time, low-to-high-level output
- t_{PHL} = Propagation delay time, high-to-low-level output
- t_{PZH} = Output enable time to high level
- t_{PZL} = Output enable time to low level
- t_{PHZ} = Output disable time from high level
- t_{PLZ} = Output disable time from low level

NOTE 2: Load circuits and voltage waveforms are shown in Section 1.

勝特力材料 886-3-5753170
胜特力电子(上海) 86-21-54151736
胜特力电子(深圳) 86-755-83298787
[Http://www.100y.com.tw](http://www.100y.com.tw)

schematics of inputs and outputs

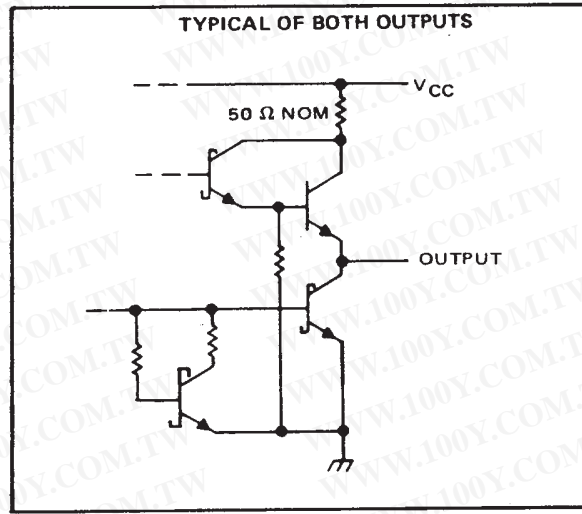
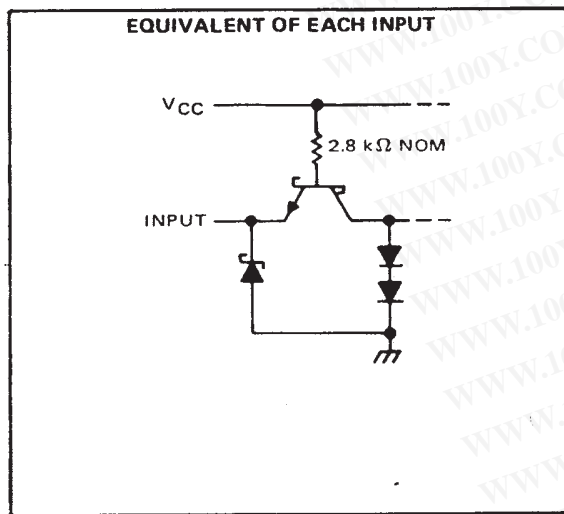

勝特力材料 886-3-5753170
 勝特力电子(上海) 86-21-54151736
 勝特力电子(深圳) 86-755-83298787
[Http://www.100y.com.tw](http://www.100y.com.tw)

PACKAGING INFORMATION

Orderable Device	Status ⁽¹⁾	Package Type	Package Drawing	Pins	Package Qty	Eco Plan ⁽²⁾	Lead/Ball Finish	MSL Peak Temp ⁽³⁾
7601601EA	ACTIVE	CDIP	J	16	1	TBD	A42 SNPB	N / A for Pkg Type
7601601FA	ACTIVE	CFP	W	16	1	TBD	A42	N / A for Pkg Type
7601601FA	ACTIVE	CFP	W	16	1	TBD	A42	N / A for Pkg Type
80022012A	OBSOLETE	LCCC	FK	20		TBD	Call TI	Call TI
80022012A	OBSOLETE	LCCC	FK	20		TBD	Call TI	Call TI
8002201EA	OBSOLETE	CDIP	J	16		TBD	Call TI	Call TI
8002201EA	OBSOLETE	CDIP	J	16		TBD	Call TI	Call TI
8002201FA	OBSOLETE	CFP	W	16		TBD	Call TI	Call TI
8002201FA	OBSOLETE	CFP	W	16		TBD	Call TI	Call TI
JM38510/07905BEA	OBSOLETE	CDIP	J	16		TBD	Call TI	Call TI
JM38510/07905BEA	OBSOLETE	CDIP	J	16		TBD	Call TI	Call TI
JM38510/30905B2A	ACTIVE	LCCC	FK	20	1	TBD	POST-PLATE	N / A for Pkg Type
JM38510/30905B2A	ACTIVE	LCCC	FK	20	1	TBD	POST-PLATE	N / A for Pkg Type
JM38510/30905BEA	ACTIVE	CDIP	J	16	1	TBD	A42 SNPB	N / A for Pkg Type
JM38510/30905BEA	ACTIVE	CDIP	J	16	1	TBD	A42 SNPB	N / A for Pkg Type
JM38510/30905BFA	ACTIVE	CFP	W	16	1	TBD	A42	N / A for Pkg Type
JM38510/30905BFA	ACTIVE	CFP	W	16	1	TBD	A42	N / A for Pkg Type
SN54251J	OBSOLETE	CDIP	J	16		TBD	Call TI	Call TI
SN54251J	OBSOLETE	CDIP	J	16		TBD	Call TI	Call TI
SN54LS251J	ACTIVE	CDIP	J	16	1	TBD	A42 SNPB	N / A for Pkg Type
SN54LS251J	ACTIVE	CDIP	J	16	1	TBD	A42 SNPB	N / A for Pkg Type
SN54S251J	OBSOLETE	CDIP	J	16		TBD	Call TI	Call TI
SN54S251J	OBSOLETE	CDIP	J	16		TBD	Call TI	Call TI
SN74251N	OBSOLETE	PDIP	N	16		TBD	Call TI	Call TI
SN74251N	OBSOLETE	PDIP	N	16		TBD	Call TI	Call TI
SN74251N3	OBSOLETE	PDIP	N	16		TBD	Call TI	Call TI
SN74251N3	OBSOLETE	PDIP	N	16		TBD	Call TI	Call TI
SN74LS251D	ACTIVE	SOIC	D	16	40	Green (RoHS & no Sb/Br)	CU NIPDAU	Level-1-260C-UNLIM
SN74LS251D	ACTIVE	SOIC	D	16	40	Green (RoHS & no Sb/Br)	CU NIPDAU	Level-1-260C-UNLIM
SN74LS251DE4	ACTIVE	SOIC	D	16	40	Green (RoHS & no Sb/Br)	CU NIPDAU	Level-1-260C-UNLIM
SN74LS251DE4	ACTIVE	SOIC	D	16	40	Green (RoHS & no Sb/Br)	CU NIPDAU	Level-1-260C-UNLIM
SN74LS251DR	ACTIVE	SOIC	D	16	2500	Green (RoHS & no Sb/Br)	CU NIPDAU	Level-1-260C-UNLIM
SN74LS251DR	ACTIVE	SOIC	D	16	2500	Green (RoHS & no Sb/Br)	CU NIPDAU	Level-1-260C-UNLIM
SN74LS251DRE4	ACTIVE	SOIC	D	16	2500	Green (RoHS & no Sb/Br)	CU NIPDAU	Level-1-260C-UNLIM
SN74LS251DRE4	ACTIVE	SOIC	D	16	2500	Green (RoHS & no Sb/Br)	CU NIPDAU	Level-1-260C-UNLIM
SN74LS251N	ACTIVE	PDIP	N	16	25	Pb-Free (RoHS)	CU NIPDAU	N / A for Pkg Type

Orderable Device	Status ⁽¹⁾	Package Type	Package Drawing	Pins	Package Qty	Eco Plan ⁽²⁾	Lead/Ball Finish	MSL Peak Temp ⁽³⁾
SN74LS251N	ACTIVE	PDIP	N	16	25	Pb-Free (RoHS)	CU NIPDAU	N / A for Pkg Type
SN74LS251N3	OBSOLETE	PDIP	N	16		TBD	Call TI	Call TI
SN74LS251N3	OBSOLETE	PDIP	N	16		TBD	Call TI	Call TI
SN74LS251NE4	ACTIVE	PDIP	N	16	25	Pb-Free (RoHS)	CU NIPDAU	N / A for Pkg Type
SN74LS251NE4	ACTIVE	PDIP	N	16	25	Pb-Free (RoHS)	CU NIPDAU	N / A for Pkg Type
SN74LS251NSR	ACTIVE	SO	NS	16	2000	Green (RoHS & no Sb/Br)	CU NIPDAU	Level-1-260C-UNLIM
SN74LS251NSR	ACTIVE	SO	NS	16	2000	Green (RoHS & no Sb/Br)	CU NIPDAU	Level-1-260C-UNLIM
SN74LS251NSRE4	ACTIVE	SO	NS	16	2000	Green (RoHS & no Sb/Br)	CU NIPDAU	Level-1-260C-UNLIM
SN74LS251NSRE4	ACTIVE	SO	NS	16	2000	Green (RoHS & no Sb/Br)	CU NIPDAU	Level-1-260C-UNLIM
SN74S251D	OBSOLETE	SOIC	D	16		TBD	Call TI	Call TI
SN74S251D	OBSOLETE	SOIC	D	16		TBD	Call TI	Call TI
SN74S251N	OBSOLETE	PDIP	N	16		TBD	Call TI	Call TI
SN74S251N	OBSOLETE	PDIP	N	16		TBD	Call TI	Call TI
SN74S251N3	OBSOLETE	PDIP	N	16		TBD	Call TI	Call TI
SN74S251N3	OBSOLETE	PDIP	N	16		TBD	Call TI	Call TI
SNJ54251J	OBSOLETE	CDIP	J	16		TBD	Call TI	Call TI
SNJ54251J	OBSOLETE	CDIP	J	16		TBD	Call TI	Call TI
SNJ54LS251FK	ACTIVE	LCCC	FK	20	1	TBD	POST-PLATE	N / A for Pkg Type
SNJ54LS251FK	ACTIVE	LCCC	FK	20	1	TBD	POST-PLATE	N / A for Pkg Type
SNJ54LS251J	ACTIVE	CDIP	J	16	1	TBD	A42 SNPB	N / A for Pkg Type
SNJ54LS251J	ACTIVE	CDIP	J	16	1	TBD	A42 SNPB	N / A for Pkg Type
SNJ54LS251W	ACTIVE	CFP	W	16	1	TBD	A42	N / A for Pkg Type
SNJ54LS251W	ACTIVE	CFP	W	16	1	TBD	A42	N / A for Pkg Type
SNJ54S251FK	OBSOLETE	LCCC	FK	20		TBD	Call TI	Call TI
SNJ54S251FK	OBSOLETE	LCCC	FK	20		TBD	Call TI	Call TI
SNJ54S251J	OBSOLETE	CDIP	J	16		TBD	Call TI	Call TI
SNJ54S251J	OBSOLETE	CDIP	J	16		TBD	Call TI	Call TI
SNJ54S251W	OBSOLETE	CFP	W	16		TBD	Call TI	Call TI
SNJ54S251W	OBSOLETE	CFP	W	16		TBD	Call TI	Call TI

⁽¹⁾ The marketing status values are defined as follows:

ACTIVE: Product device recommended for new designs.

LIFEBUY: TI has announced that the device will be discontinued, and a lifetime-buy period is in effect.

NRND: Not recommended for new designs. Device is in production to support existing customers, but TI does not recommend using this part in a new design.

PREVIEW: Device has been announced but is not in production. Samples may or may not be available.

OBSOLETE: TI has discontinued the production of the device.

⁽²⁾ Eco Plan - The planned eco-friendly classification: Pb-Free (RoHS), Pb-Free (RoHS Exempt), or Green (RoHS & no Sb/Br) - please check <http://www.ti.com/productcontent> for the latest availability information and additional product content details.

TBD: The Pb-Free/Green conversion plan has not been defined.

Pb-Free (RoHS): TI's terms "Lead-Free" or "Pb-Free" mean semiconductor products that are compatible with the current RoHS requirements

for all 6 substances, including the requirement that lead not exceed 0.1% by weight in homogeneous materials. Where designed to be soldered at high temperatures, TI Pb-Free products are suitable for use in specified lead-free processes.

Pb-Free (RoHS Exempt): This component has a RoHS exemption for either 1) lead-based flip-chip solder bumps used between the die and package, or 2) lead-based die adhesive used between the die and leadframe. The component is otherwise considered Pb-Free (RoHS compatible) as defined above.

Green (RoHS & no Sb/Br): TI defines "Green" to mean Pb-Free (RoHS compatible), and free of Bromine (Br) and Antimony (Sb) based flame retardants (Br or Sb do not exceed 0.1% by weight in homogeneous material)

(3) MSL, Peak Temp. -- The Moisture Sensitivity Level rating according to the JEDEC industry standard classifications, and peak solder temperature.

Important Information and Disclaimer:The information provided on this page represents TI's knowledge and belief as of the date that it is provided. TI bases its knowledge and belief on information provided by third parties, and makes no representation or warranty as to the accuracy of such information. Efforts are underway to better integrate information from third parties. TI has taken and continues to take reasonable steps to provide representative and accurate information but may not have conducted destructive testing or chemical analysis on incoming materials and chemicals. TI and TI suppliers consider certain information to be proprietary, and thus CAS numbers and other limited information may not be available for release.

In no event shall TI's liability arising out of such information exceed the total purchase price of the TI part(s) at issue in this document sold by TI to Customer on an annual basis.

J (R-GDIP-T**)

14 LEADS SHOWN

CERAMIC DUAL IN-LINE PACKAGE

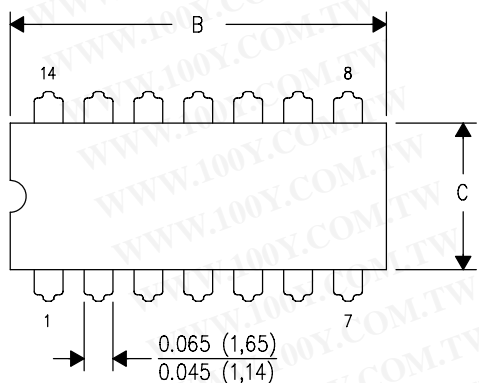

DIM	PINS **			
	14	16	18	20
A	0.300 (7,62) BSC	0.300 (7,62) BSC	0.300 (7,62) BSC	0.300 (7,62) BSC
B MAX	0.785 (19,94)	.840 (21,34)	0.960 (24,38)	1.060 (26,92)
B MIN	—	—	—	—
C MAX	0.300 (7,62)	0.300 (7,62)	0.310 (7,87)	0.300 (7,62)
C MIN	0.245 (6,22)	0.245 (6,22)	0.220 (5,59)	0.245 (6,22)

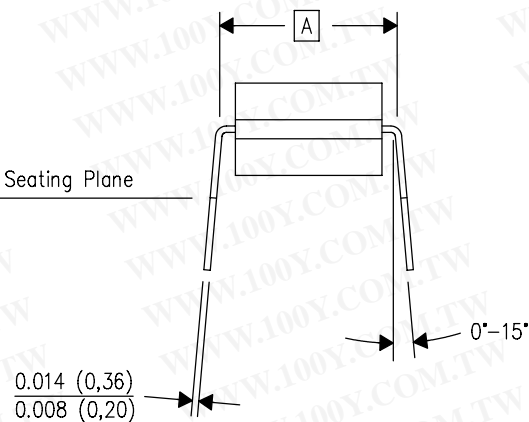
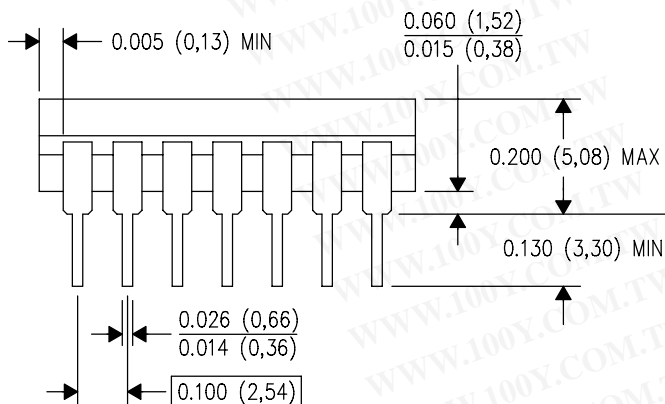

勝特力材料 886-3-5753170
 勝特力电子(上海) 86-21-54151736
 勝特力电子(深圳) 86-755-83298787
[Http://www.100y.com.tw](http://www.100y.com.tw)

4040083/F 03/03

- NOTES:
- A. All linear dimensions are in inches (millimeters).
 - B. This drawing is subject to change without notice.
 - C. This package is hermetically sealed with a ceramic lid using glass frit.
 - D. Index point is provided on cap for terminal identification only on press ceramic glass frit seal only.
 - E. Falls within MIL STD 1835 GDIP1-T14, GDIP1-T16, GDIP1-T18 and GDIP1-T20.

W (R-GDFP-F16)

CERAMIC DUAL FLATPACK

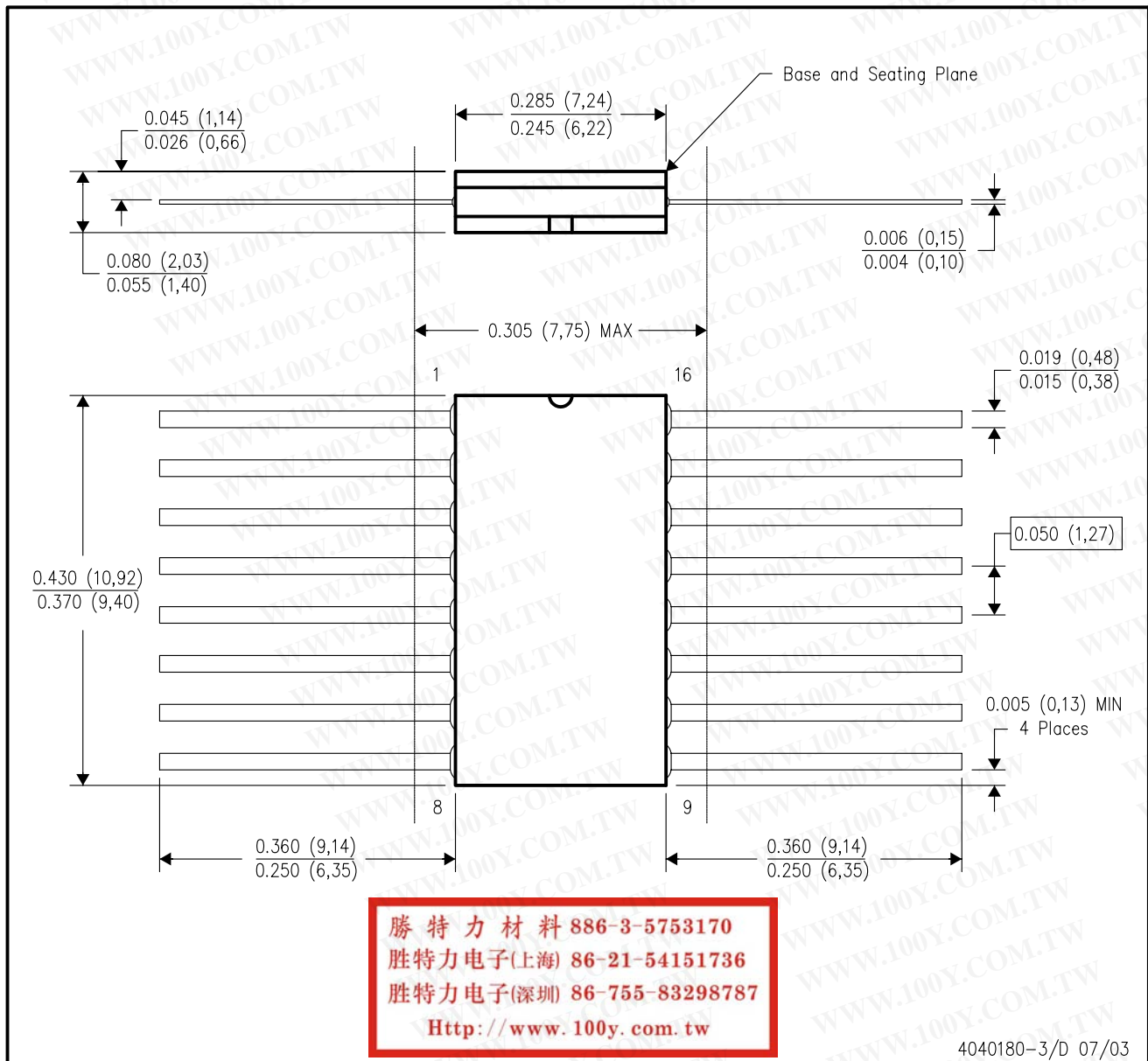

- NOTES:
- A. All linear dimensions are in inches (millimeters).
 - B. This drawing is subject to change without notice.
 - C. This package can be hermetically sealed with a ceramic lid using glass frit.
 - D. Index point is provided on cap for terminal identification only.
 - E. Falls within MIL STD 1835 GDFP1-F16 and JEDEC MO-092AC

FK (S-CQCC-N**)

LEADLESS CERAMIC CHIP CARRIER

28 TERMINAL SHOWN

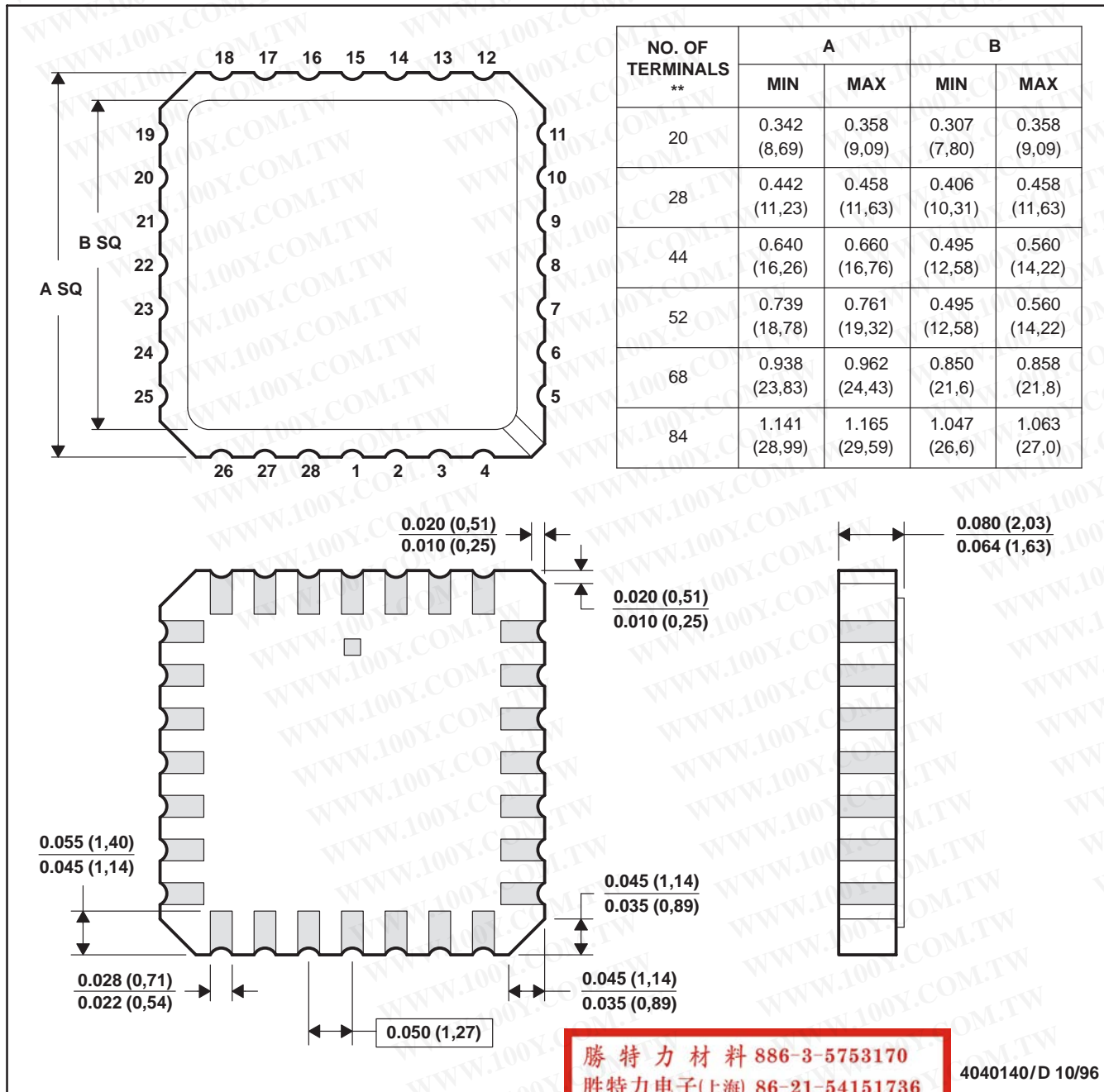

- NOTES:
- A. All linear dimensions are in inches (millimeters).
 - B. This drawing is subject to change without notice.
 - C. This package can be hermetically sealed with a metal lid.
 - D. The terminals are gold plated.
 - E. Falls within JEDEC MS-004

勝特力材料 886-3-5753170
 勝特力电子(上海) 86-21-54151736
 勝特力电子(深圳) 86-755-83298787
[Http://www.100y.com.tw](http://www.100y.com.tw)

4040140/D 10/96

N (R-PDIP-T**)

PLASTIC DUAL-IN-LINE PACKAGE

16 PINS SHOWN

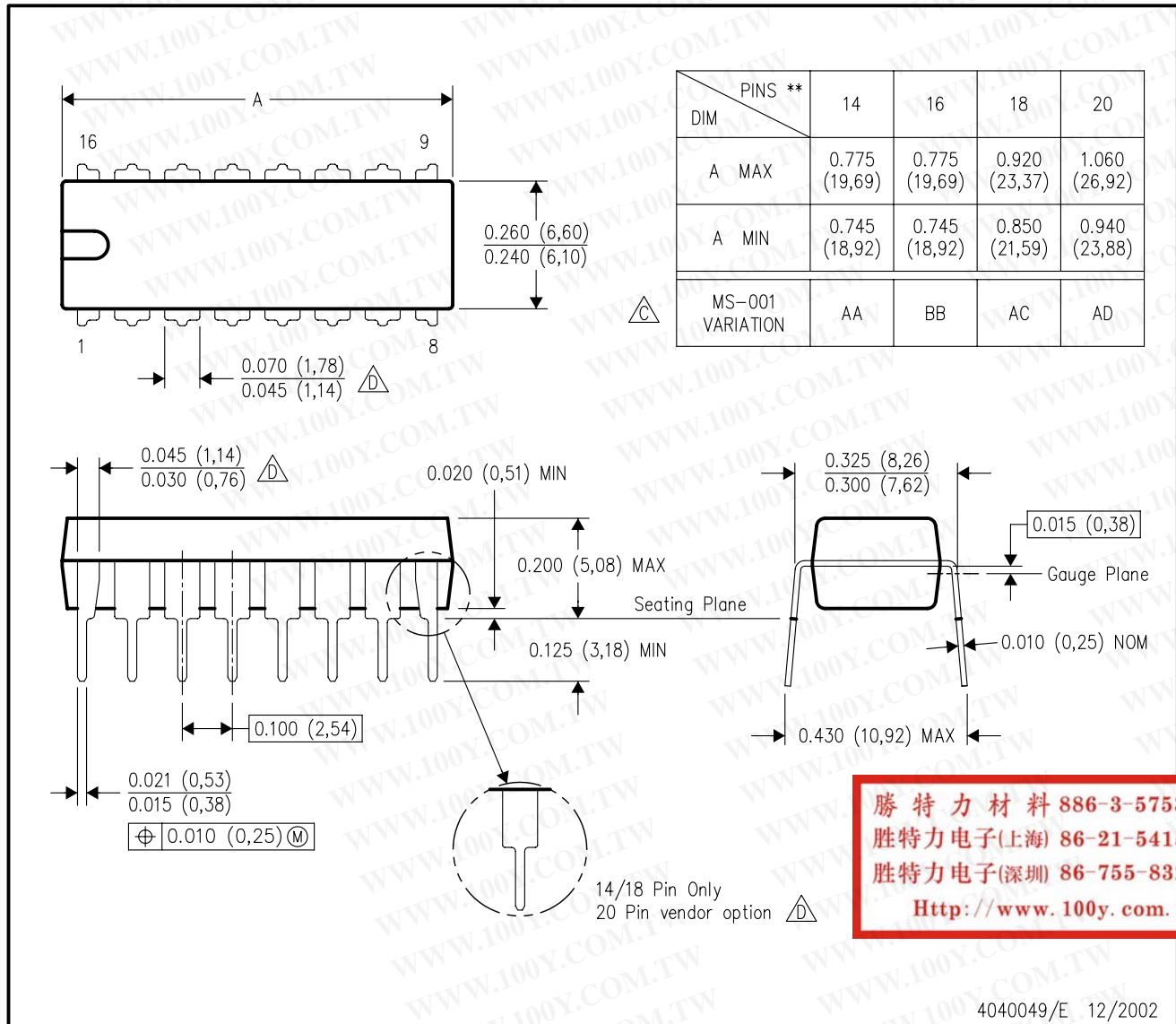

勝特力材料 886-3-5753170
 勝特力电子(上海) 86-21-54151736
 勝特力电子(深圳) 86-755-83298787
[Http://www.100y.com.tw](http://www.100y.com.tw)

4040049/E 12/2002

- NOTES:
- A. All linear dimensions are in inches (millimeters).
 - B. This drawing is subject to change without notice.
 - Falls within JEDEC MS-001, except 18 and 20 pin minimum body length (Dim A).
 - The 20 pin end lead shoulder width is a vendor option, either half or full width.

D (R-PDSO-G16)

PLASTIC SMALL-OUTLINE PACKAGE

勝特力材料 886-3-5753170
勝特力电子(上海) 86-21-54151736
勝特力电子(深圳) 86-755-83298787
Http://www.100y.com.tw

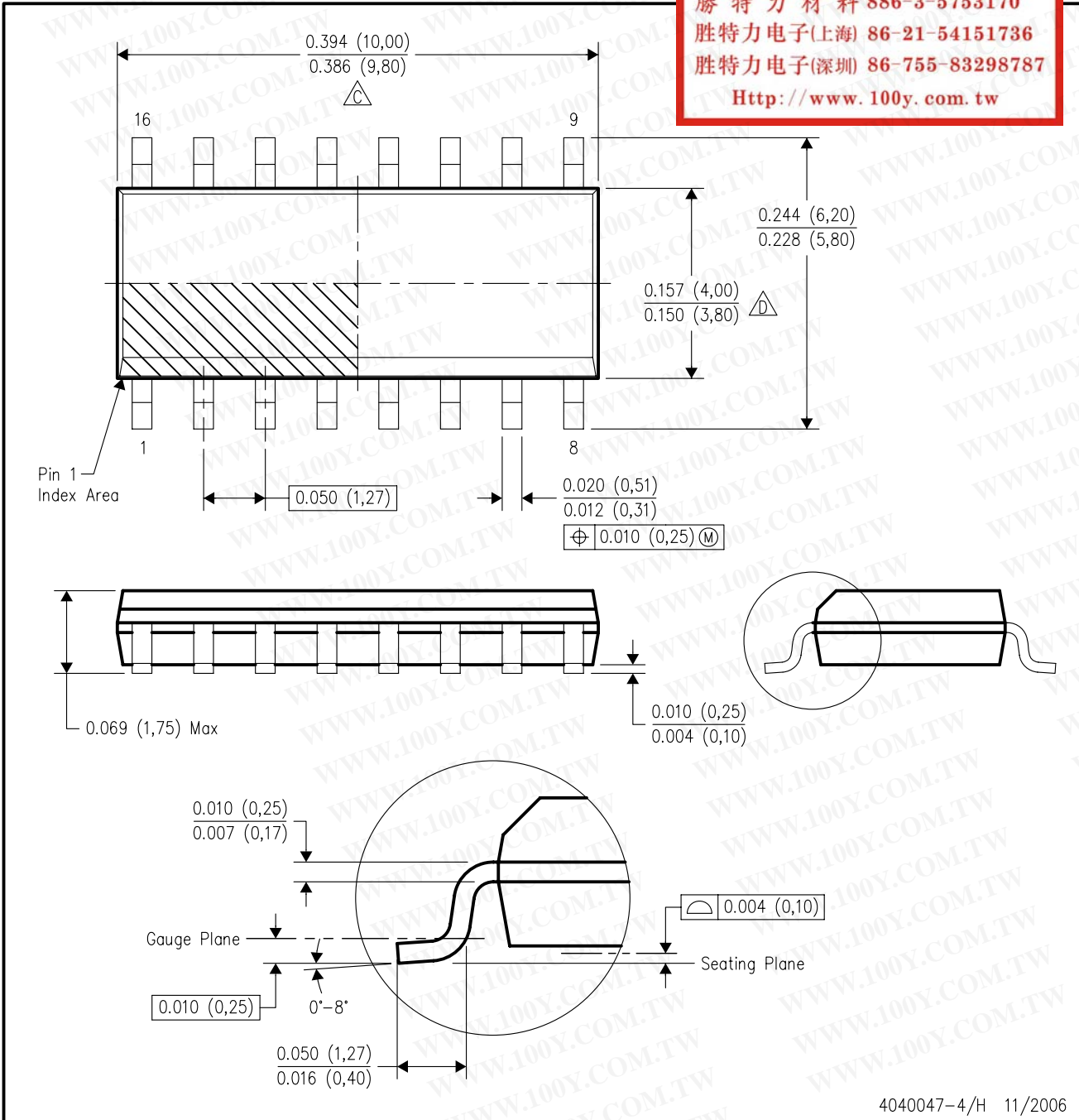

4040047-4/H 11/2006

MECHANICAL DATA

NS (R-PDSO-G)**

PLASTIC SMALL-OUTLINE PACKAGE

14-PINS SHOWN

勝特力材料 886-3-5753170
 勝特力电子(上海) 86-21-54151736
 勝特力电子(深圳) 86-755-83298787
[Http://www.100y.com.tw](http://www.100y.com.tw)

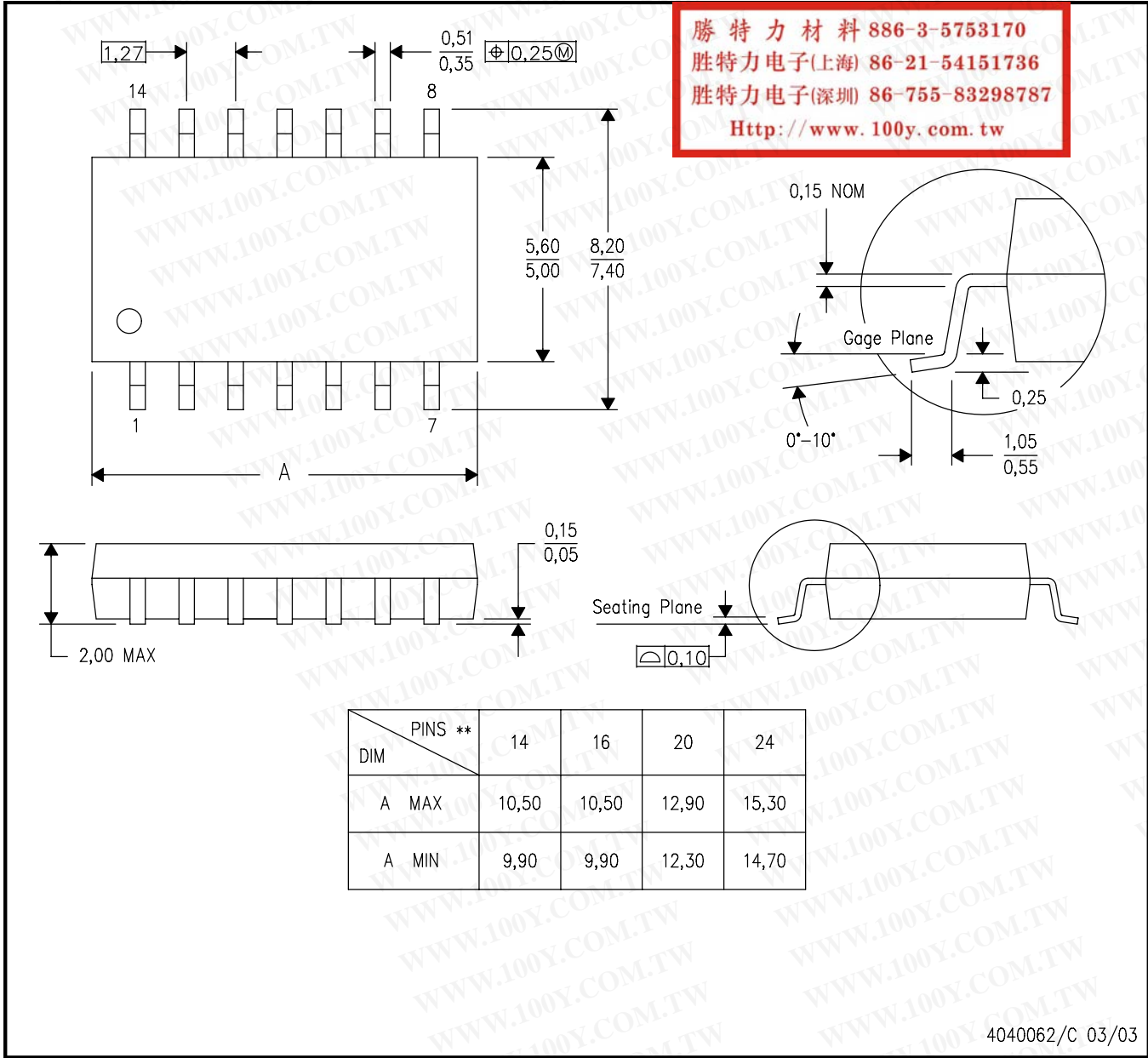

- NOTES:
- A. All linear dimensions are in millimeters.
 - B. This drawing is subject to change without notice.
 - C. Body dimensions do not include mold flash or protrusion, not to exceed 0,15.