

TLV1543C, TLV1543M 3.3-V 10-BIT ANALOG-TO-DIGITAL CONVERTERS WITH SERIAL CONTROL AND 11 ANALOG INPUTS

SLAS072C – DECEMBER 1992 – REVISED MARCH 1995

- 3.3-V Supply Operation
- 10-Bit-Resolution A/D Converter
- 11 Analog Input Channels
- Three Built-In Self-Test Modes
- Inherent Sample and Hold
- Total Unadjusted Error . . . ± 1 LSB Max
- On-Chip System Clock
- End-of-Conversion (EOC) Output
- Pin Compatible With TLC1543
- CMOS Technology

description

The TLV1543C and TLV1543M are CMOS 10-bit, switched-capacitor, successive-approximation, analog-to-digital converters. These devices have three inputs and a 3-state output [chip select (\overline{CS}), input-output clock (I/O CLOCK), address input (ADDRESS), and data output (DATA OUT)] that provide a direct 4-wire interface to the serial port of a host processor. The devices allow high-speed data transfers from the host.

In addition to a high-speed A/D converter and versatile control capability, these devices have an on-chip 14-channel multiplexer that can select any one of 11 analog inputs or any one of three internal self-test voltages. The sample-and-hold function is automatic. At the end of A/D conversion, the end-of-conversion (EOC) output goes high to indicate that conversion is complete. The converter incorporated in the devices features differential high-impedance reference inputs that facilitate ratiometric conversion, scaling, and isolation of analog circuitry from logic and supply noise. A switched-capacitor design allows low-error conversion over the full operating free-air temperature range.

The TLV1543C is characterized for operation from 0°C to 70°C. The TLV1543M is characterized for operation over the full military temperature range of -55°C to 125°C.

DB, DW, FK, J, OR N PACKAGE
 (TOP VIEW)

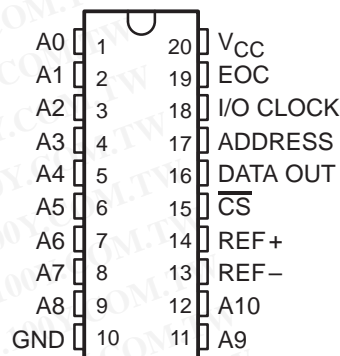

FN PACKAGE
 (TOP VIEW)

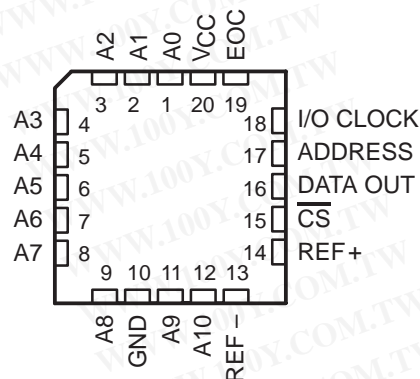

AVAILABLE OPTIONS

T _A	PACKAGE					
	SMALL OUTLINE (DB)	SMALL OUTLINE (DW)	CHIP CARRIER (FK)	CERAMIC DIP (J)	PLASTIC DIP (N)	PLASTIC CHIP CARRIER (FN)
0°C to 70°C	TLV1543CDB	TLV1543CDW	—	—	TLV1543CN	TLV1543CFN
-55°C to 125°C	—	—	TLV1543MFK	TLV1543MJ	—	—



Please be aware that an important notice concerning availability, standard warranty, and use in critical applications of Texas Instruments semiconductor products and disclaimers thereto appears at the end of this data sheet.

PRODUCTION DATA information is current as of publication date. Products conform to specifications per the terms of Texas Instruments standard warranty. Production processing does not necessarily include testing of all parameters.



POST OFFICE BOX 655303 • DALLAS, TEXAS 75265

Copyright © 1995, Texas Instruments Incorporated

TLV1543C, TLV1543M
3.3-V 10-BIT ANALOG-TO-DIGITAL CONVERTERS
WITH SERIAL CONTROL AND 11 ANALOG INPUTS

SLAS072C – DECEMBER 1992 – REVISED MARCH 1995

functional block diagram

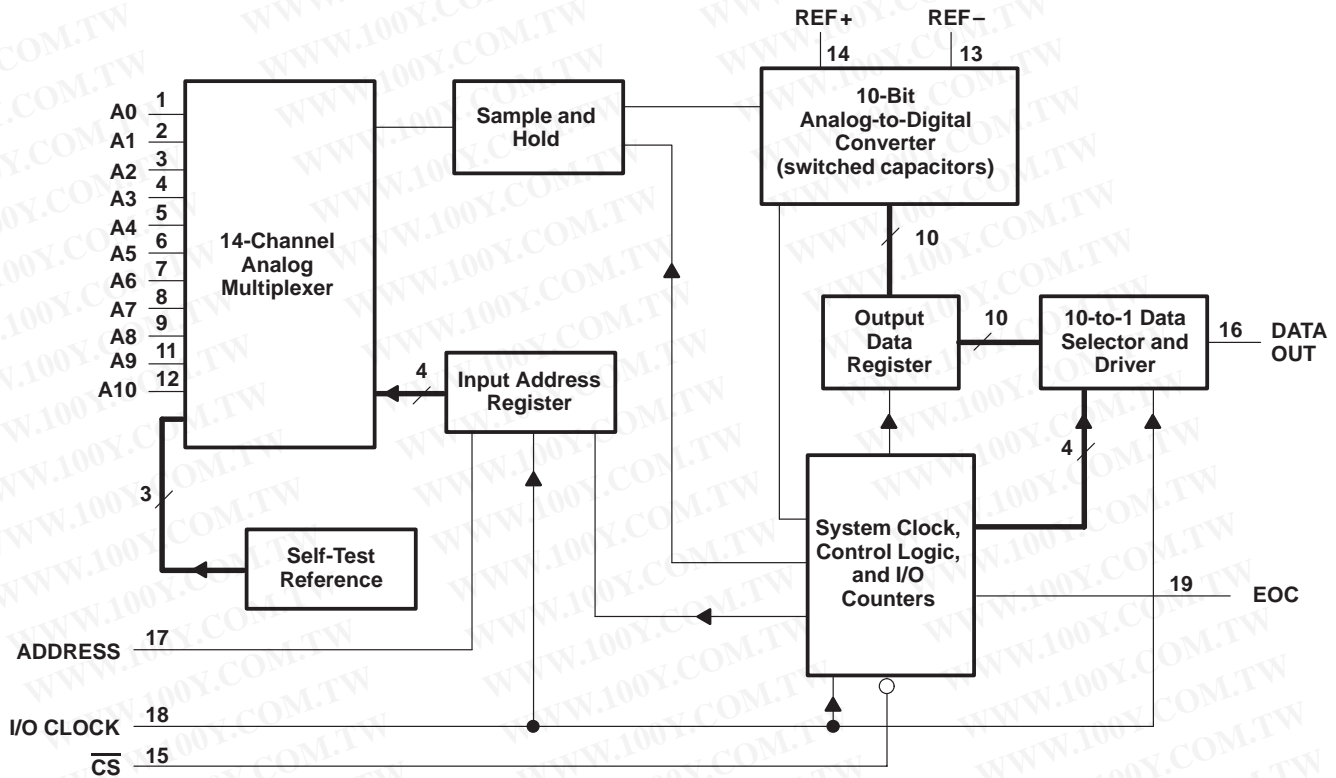

typical equivalent inputs

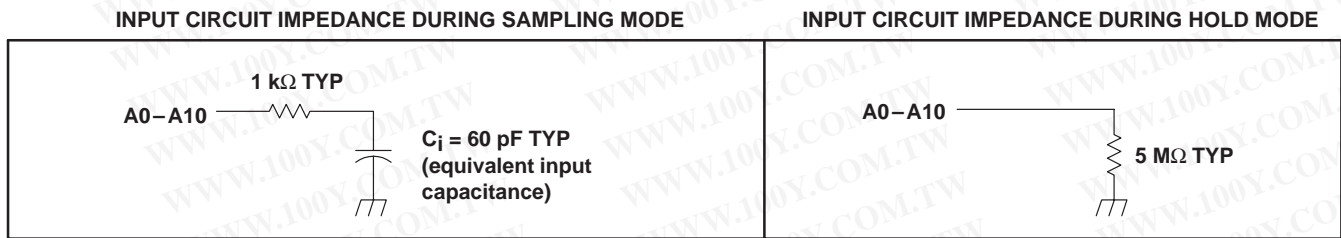

勝特力材料 886-3-5753170
 勝特力电子(上海) 86-21-54151736
 勝特力电子(深圳) 86-755-83298787
[Http://www.100y.com.tw](http://www.100y.com.tw)

TLV1543C, TLV1543M
3.3-V 10-BIT ANALOG-TO-DIGITAL CONVERTERS
WITH SERIAL CONTROL AND 11 ANALOG INPUTS

SLAS072C – DECEMBER 1992 – REVISED MARCH 1995

Terminal Functions

TERMINAL NAME	NO.	I/O	DESCRIPTION
ADDRESS	17	I	Serial address. A 4-bit serial address selects the desired analog input or test voltage that is to be converted next. The address data is presented with the MSB first and is shifted in on the first four rising edges of I/O CLOCK. After the four address bits have been read into the address register, ADDRESS is ignored for the remainder of the current conversion period.
A0–A10	1–9, 11, 12	I	Analog signal. The 11 analog inputs are applied to A0–A10 and are internally multiplexed. The driving source impedance should be less than or equal to 1 k Ω .
$\overline{\text{CS}}$	15	I	Chip select. A high-to-low transition on $\overline{\text{CS}}$ resets the internal counters and controls and enables DATA OUT, ADDRESS, and I/O CLOCK within a maximum of a setup time plus two falling edges of the internal system clock. A low-to-high transition disables ADDRESS and I/O CLOCK within a setup time plus two falling edges of the internal system clock.
DATA OUT	16	O	The 3-state serial output for the A/D conversion result. DATA OUT is in the high-impedance state when $\overline{\text{CS}}$ is high and active when $\overline{\text{CS}}$ is low. With a valid chip select, DATA OUT is removed from the high-impedance state and is driven to the logic level corresponding to the MSB value of the previous conversion result. The next falling edge of I/O CLOCK drives DATA OUT to the logic level corresponding to the next most significant bit, and the remaining bits are shifted out in order with the LSB appearing on the ninth falling edge of I/O CLOCK. On the tenth falling edge of I/O CLOCK, DATA OUT is driven to a low logic level so that serial interface data transfers of more than ten clocks produce zeroes as the unused LSBs.
EOC	19	O	End of conversion. EOC goes from a high- to a low- logic level on the trailing edge of the tenth I/O CLOCK and remains low until the conversion is complete and data are ready for transfer.
GND	10	I	The ground return terminal for the internal circuitry. Unless otherwise noted, all voltage measurements are with respect to GND.
I/O CLOCK	18	I	Input/output clock. I/O CLOCK receives the serial I/O CLOCK input and performs the following four functions: 1) It clocks the four input address bits into the address register on the first four rising edges of I/O CLOCK with the multiplex address available after the fourth rising edge. 2) On the fourth falling edge of I/O CLOCK, the analog input voltage on the selected multiplex input begins charging the capacitor array and continues to do so until the tenth falling edge of I/O CLOCK. 3) It shifts the nine remaining bits of the previous conversion data out on DATA OUT. 4) It transfers control of the conversion to the internal state controller on the falling edge of the tenth clock.
REF +	14	I	The upper reference voltage value (nominally V_{CC}) is applied to REF +. The maximum input voltage range is determined by the difference between the voltage applied to REF + and the voltage applied to the REF – terminal.
REF –	13	I	The lower reference voltage value (nominally ground) is applied to REF –.
VCC	20	I	Positive supply voltage

detailed description

With chip select ($\overline{\text{CS}}$) inactive (high), the ADDRESS and I/O CLOCK inputs are initially disabled and DATA OUT is in the high-impedance state. When the serial interface takes $\overline{\text{CS}}$ active (low), the conversion sequence begins with the enabling of I/O CLOCK and ADDRESS and the removal of DATA OUT from the high-impedance state. The host then provides the 4-bit channel address to ADDRESS and the I/O CLOCK sequence to I/O CLOCK. During this transfer, the host serial interface also receives the previous conversion result from DATA OUT. I/O CLOCK receives an input sequence that is between 10 and 16 clocks long from the host. The first four I/O clocks load the address register with the 4-bit address on ADDRESS selecting the desired analog channel and the next six clocks providing the control timing for sampling the analog input.

勝特力材料 886-3-5753170
勝特力电子(上海) 86-21-54151736
勝特力电子(深圳) 86-755-83298787
[Http://www.100y.com.tw](http://www.100y.com.tw)



TLV1543C, TLV1543M

3.3-V 10-BIT ANALOG-TO-DIGITAL CONVERTERS WITH SERIAL CONTROL AND 11 ANALOG INPUTS

SLAS072C – DECEMBER 1992 – REVISED MARCH 1995

detailed description (continued)

There are six basic serial interface timing modes that can be used with the device. These modes are determined by the speed of I/O CLOCK and the operation of \overline{CS} as shown in Table 1. These modes are (1) a fast mode with a 10-clock transfer and \overline{CS} inactive (high) between conversion cycles, (2) a fast mode with a 10-clock transfer and \overline{CS} active (low) continuously, (3) a fast mode with an 11- to 16-clock transfer and \overline{CS} inactive (high) between conversion cycles, (4) a fast mode with a 16-bit transfer and \overline{CS} active (low) continuously, (5) a slow mode with an 11- to 16-clock transfer and \overline{CS} inactive (high) between conversion cycles, and (6) a slow mode with a 16-clock transfer and \overline{CS} active (low) continuously.

The MSB of the previous conversion appears on DATA OUT on the falling edge of \overline{CS} in mode 1, mode 3, and mode 5, on the rising edge of EOC in mode 2 and mode 4, and following the 16th clock falling edge in mode 6. The remaining nine bits are shifted out on the next nine falling edges of I/O CLOCK. Ten bits of data are transmitted to the host through DATA OUT. The number of serial clock pulses used also depends on the mode of operation, but a minimum of ten clock pulses is required for conversion to begin. On the 10th clock falling edge, the EOC output goes low and returns to the high logic level when conversion is complete and the result can be read by the host. On the 10th clock falling edge, the internal logic takes DATA OUT low to ensure that the remaining bit values are zero if the I/O CLOCK transfer is more than ten clocks long.

Table 1 lists the operational modes with respect to the state of \overline{CS} , the number of I/O serial transfer clocks that can be used, and the timing edge on which the MSB of the previous conversion appears at the output.

Table 1. Mode Operation

MODES		\overline{CS}	NO. OF I/O CLOCKS	MSB AT DATA OUT†	TIMING DIAGRAM
Fast Modes	Mode 1	High between conversion cycles	10	\overline{CS} falling edge	Figure 9
	Mode 2	Low continuously	10	EOC rising edge	Figure 10
	Mode 3	High between conversion cycles	11 to 16‡	\overline{CS} falling edge	Figure 11
	Mode 4	Low continuously	16‡	EOC rising edge	Figure 12
Slow Modes	Mode 5	High between conversion cycles	11 to 16‡	\overline{CS} falling edge	Figure 13
	Mode 6	Low continuously	16‡	16th clock falling edge	Figure 14

† These edges also initiate serial-interface communication.

‡ No more than 16 clocks should be used.

fast modes

The device is in a fast mode when the serial I/O CLOCK data transfer is completed before the conversion is completed. With a 10-clock serial transfer, the device can only run in a fast mode since a conversion does not begin until the falling edge of the 10th I/O CLOCK.

mode 1: fast mode, \overline{CS} inactive (high) between conversion cycles, 10-clock transfer

In this mode, \overline{CS} is inactive (high) between serial I/O CLOCK transfers and each transfer is ten clocks long. The falling edge of \overline{CS} begins the sequence by removing DATA OUT from the high-impedance state. The rising edge of \overline{CS} ends the sequence by returning DATA OUT to the high-impedance state within the specified delay time. Also, the rising edge of \overline{CS} disables the I/O CLOCK and ADDRESS terminals within a setup time plus two falling edges of the internal system clock.

mode 2: fast mode, \overline{CS} active (low) continuously, 10-clock transfer

In this mode, \overline{CS} is active (low) between serial I/O CLOCK transfers and each transfer is ten clocks long. After the initial conversion cycle, \overline{CS} is held active (low) for subsequent conversions; the rising edge of EOC then begins each sequence by removing DATA OUT from the low logic level, allowing the MSB of the previous conversion to appear immediately on this output.

勝特力材料 886-3-5753170
 勝特力电子(上海) 86-21-54151736
 勝特力电子(深圳) 86-755-83298787
[Http://www.100y.com.tw](http://www.100y.com.tw)



mode 3: fast mode, \overline{CS} inactive (high) between conversion cycles, 11- to 16-clock transfer

In this mode, \overline{CS} is inactive (high) between serial I/O CLOCK transfers and each transfer can be 11 to 16 clocks long. The falling edge of \overline{CS} begins the sequence by removing DATA OUT from the high-impedance state. The rising edge of \overline{CS} ends the sequence by returning DATA OUT to the high-impedance state within the specified delay time. Also, the rising edge of \overline{CS} disables the I/O CLOCK and ADDRESS terminals within a setup time plus two falling edges of the internal system clock.

mode 4: fast mode, \overline{CS} active (low) continuously, 16-clock transfer

In this mode, \overline{CS} is active (low) between serial I/O CLOCK transfers and each transfer must be exactly 16 clocks long. After the initial conversion cycle, \overline{CS} is held active (low) for subsequent conversions; the rising edge of EOC then begins each sequence by removing DATA OUT from the low logic level, allowing the MSB of the previous conversion to appear immediately on this output.

slow modes

In a slow mode, the conversion is completed before the serial I/O CLOCK data transfer is completed. A slow mode requires a minimum 11-clock transfer into I/O CLOCK, and the rising edge of the eleventh clock must occur before the conversion period is complete; otherwise, the device loses synchronization with the host serial interface, and \overline{CS} has to be toggled to initialize the system. The eleventh rising edge of the I/O CLOCK must occur within 9.5 μ s after the tenth I/O clock falling edge.

mode 5: slow mode, \overline{CS} inactive (high) between conversion cycles, 11- to 16-clock transfer

In this mode, \overline{CS} is inactive (high) between serial I/O CLOCK transfers and each transfer can be 11 to 16 clocks long. The falling edge of \overline{CS} begins the sequence by removing DATA OUT from the high-impedance state. The rising edge of \overline{CS} ends the sequence by returning DATA OUT to the high-impedance state within the specified delay time. Also, the rising edge of \overline{CS} disables the I/O CLOCK and ADDRESS terminals within a setup time plus two falling edges of the internal system clock.

mode 6: slow mode, \overline{CS} active (low) continuously, 16-clock transfer

In this mode, \overline{CS} is active (low) between serial I/O CLOCK transfers and each transfer must be exactly 16 clocks long. After the initial conversion cycle, \overline{CS} is held active (low) for subsequent conversions. The falling edge of the sixteenth I/O CLOCK then begins each sequence by removing DATA OUT from the low state, allowing the MSB of the previous conversion to appear immediately at DATA OUT. The device is then ready for the next 16-clock transfer initiated by the serial interface.

address bits

The 4-bit analog channel-select address for the next conversion cycle is presented to the ADDRESS terminal (MSB first) and is clocked into the address register on the first four leading edges of I/O CLOCK. This address selects one of 14 inputs (11 analog inputs or 3 internal test inputs).

analog inputs and test modes

The 11 analog inputs and the 3 internal test inputs are selected by the 14-channel multiplexer according to the input address as shown in Tables 2 and 3. The input multiplexer is a break-before-make type to reduce input-to-input noise injection resulting from channel switching.

Sampling of the analog input starts on the falling edge of the fourth I/O CLOCK, and sampling continues for six I/O CLOCK periods. The sample is held on the falling edge of the tenth I/O CLOCK. The three test inputs are applied to the multiplexer, sampled, and converted in the same manner as the external analog inputs.

勝特力材料 886-3-5753170
勝特力电子(上海) 86-21-54151736
勝特力电子(深圳) 86-755-83298787
[Http://www.100y.com.tw](http://www.100y.com.tw)

TLV1543C, TLV1543M
3.3-V 10-BIT ANALOG-TO-DIGITAL CONVERTERS
WITH SERIAL CONTROL AND 11 ANALOG INPUTS

SLAS072C – DECEMBER 1992 – REVISED MARCH 1995

Table 2. Analog-Channel-Select Address

ANALOG INPUT SELECTED	VALUE SHIFTED INTO ADDRESS INPUT	
	BINARY	HEX
A0	0000	0
A1	0001	1
A2	0010	2
A3	0011	3
A4	0100	4
A5	0101	5
A6	0110	6
A7	0111	7
A8	1000	8
A9	1001	9
A10	1010	A

勝特力材料 886-3-5753170
 勝特力电子(上海) 86-21-54151736
 勝特力电子(深圳) 86-755-83298787
[Http://www.100y.com.tw](http://www.100y.com.tw)

Table 3. Test-Mode-Select Address

INTERNAL SELF-TEST VOLTAGE SELECTED†	VALUE SHIFTED INTO ADDRESS INPUT		OUTPUT RESULT (HEX)‡
	BINARY	HEX	
$\frac{V_{ref+} - V_{ref-}}{2}$	1011	B	200
V_{ref-}	1100	C	000
V_{ref+}	1101	D	3FF

† V_{ref+} is the voltage applied to the REF+ input, and V_{ref-} is the voltage applied to the REF- input.

‡ The output results shown are the ideal values and vary with the reference stability and with internal offsets.

converter and analog input

The CMOS threshold detector in the successive-approximation conversion system determines each bit by examining the charge on a series of binary-weighted capacitors (see Figure 1). In the first phase of the conversion process, the analog input is sampled by closing the S_C switch and all S_T switches simultaneously. This action charges all the capacitors to the input voltage.

In the next phase of the conversion process, all S_T and S_C switches are opened and the threshold detector begins identifying bits by identifying the charge (voltage) on each capacitor relative to the reference (REF-) voltage. In the switching sequence, ten capacitors are examined separately until all ten bits are identified and the charge-convert sequence is repeated. In the first step of the conversion phase, the threshold detector looks at the first capacitor (weight = 512). Node 512 of this capacitor is switched to the REF+ voltage, and the equivalent nodes of all the other capacitors on the ladder are switched to REF-. If the voltage at the summing node is greater than the trip point of the threshold detector (approximately one-half the V_{CC} voltage), a bit 0 is placed in the output register and the 512-weight capacitor is switched to REF-. If the voltage at the summing node is less than the trip point of the threshold detector, a bit 1 is placed in the register and the 512-weight capacitor remains connected to REF+ through the remainder of the successive-approximation process. The process is repeated for the 256-weight capacitor, the 128-weight capacitor, and so forth down the line until all bits are counted.

With each step of the successive-approximation process, the initial charge is redistributed among the capacitors. The conversion process relies on charge redistribution to count and weigh the bits from MSB to LSB.



TLV1543C, TLV1543M
3.3-V 10-BIT ANALOG-TO-DIGITAL CONVERTERS
WITH SERIAL CONTROL AND 11 ANALOG INPUTS

SLAS072C – DECEMBER 1992 – REVISED MARCH 1995

converter and analog input (continued)

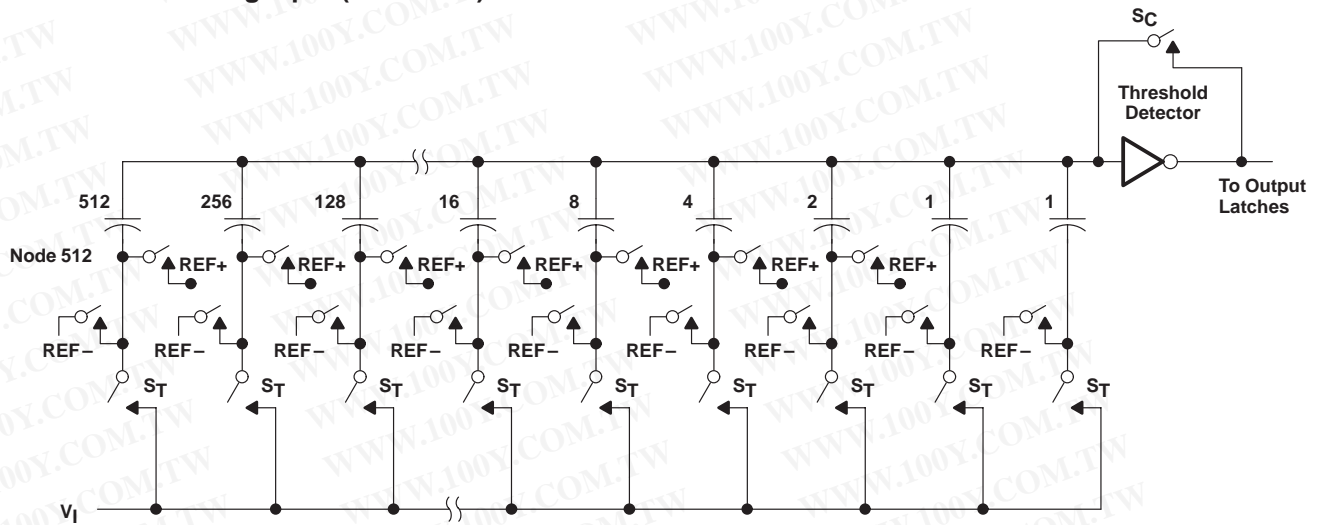

Figure 1. Simplified Model of the Successive-Approximation System

chip-select operation

The trailing edge of \overline{CS} starts all modes of operation, and \overline{CS} can abort a conversion sequence in any mode. A high-to-low transition on \overline{CS} within the specified time during an ongoing cycle aborts the cycle, and the device returns to the initial state (the contents of the output data register remain at the previous conversion result). Exercise care to prevent \overline{CS} from being taken low close to completion of conversion because the output data can be corrupted.

reference voltage inputs

There are two reference inputs used with these devices: REF+ and REF-. These voltage values establish the upper and lower limits of the analog input to produce a full-scale and zero-scale reading respectively. The values of REF+, REF-, and the analog input should not exceed the positive supply or be lower than GND consistent with the specified absolute maximum ratings. The digital output is at full scale when the input signal is equal to or higher than REF+ and at zero when the input signal is equal to or lower than REF-.

absolute maximum ratings over operating free-air temperature range (unless otherwise noted)†

Supply voltage range, V_{CC} (see Note 1): TLV1543C	-0.5 V to 6.5 V
TLV1543M	-0.5 V to 6 V
Input voltage range, V_I (any input)	-0.3 V to $V_{CC} + 0.3$ V
Output voltage range, V_O	-0.3 V to $V_{CC} + 0.3$ V
Positive reference voltage, V_{ref+}	$V_{CC} + 0.1$ V
Negative reference voltage, V_{ref-}	-0.1 V
Peak input current (any input)	± 20 mA
Peak total input current (all inputs)	± 30 mA
Operating free-air temperature range, T_A : TLV1543C	0°C to 70°C
TLV1543M	-55°C to 125°C
Storage temperature range, T_{stg}	-65°C to 150°C
Lead temperature 1,6 mm (1/16 inch) from the case for 10 seconds	260°C

† Stresses beyond those listed under "absolute maximum ratings" may cause permanent damage to the device. These are stress ratings only, and functional operation of the device at these or any other conditions beyond those indicated under "recommended operating conditions" is not implied. Exposure to absolute-maximum-rated conditions for extended periods may affect device reliability.

NOTE 1: All voltage values are with respect to digital ground with REF- and GND wired together (unless otherwise noted).



POST OFFICE BOX 655303 • DALLAS, TEXAS 75265

勝特力材料 886-3-5753170
勝特力电子(上海) 86-21-54151736
勝特力电子(深圳) 86-755-83298787
[Http://www.100y.com.tw](http://www.100y.com.tw)

TLV1543C, TLV1543M

3.3-V 10-BIT ANALOG-TO-DIGITAL CONVERTERS WITH SERIAL CONTROL AND 11 ANALOG INPUTS

SLAS072C – DECEMBER 1992 – REVISED MARCH 1995

recommended operating conditions

			MIN	NOM	MAX	UNIT
Supply voltage, V_{CC}	TLV1543C		3	3.3	5.5	V
	TLV1543M		3	3.3	3.6	V
Positive reference voltage, V_{ref+} (see Note 2)			V_{CC}			V
Negative reference voltage, V_{ref-} (see Note 2)			0			V
Differential reference voltage, $V_{ref+} - V_{ref-}$ (see Note 2)			2.5	V_{CC}	$V_{CC}+0.2$	V
Analog input voltage (see Note 2)			0	V_{CC}		V
High-level control input voltage, V_{IH}	TLV1543C	$V_{CC} = 3\text{ V to }5.5\text{ V}$	2			V
	TLV1543M	$V_{CC} = 3\text{ V to }3.6\text{ V}$	2			V
Low-level control input voltage, V_{IL}	TLV1543C	$V_{CC} = 3\text{ V to }5.5\text{ V}$			0.6	V
	TLV1543M	$V_{CC} = 3\text{ V to }3.6\text{ V}$			0.8	V
Setup time, address bits at data input before I/O CLOCK \uparrow , $t_{su}(A)$ (see Figure 4)			100			ns
Hold time, address bits after I/O CLOCK \uparrow , $t_h(A)$ (see Figure 4)			0			ns
Hold time, \overline{CS} low after last I/O CLOCK \downarrow , $t_h(\overline{CS})$			0			ns
Setup time, \overline{CS} low before clocking in first address bit, $t_{su}(\overline{CS})$ (see Note 3)			1.425			μs
Clock frequency at I/O CLOCK (see Note 4)	TLV1543C		0	1.1		MHz
	TLV1543M		0	2.1		
Pulse duration, I/O CLOCK high, $t_{wH}(I/O)$			190			ns
Pulse duration, I/O CLOCK low, $t_{wL}(I/O)$			190			ns
Transition time, I/O CLOCK, $t_t(I/O)$ (see Note 5)					1	μs
Transition time, ADDRESS and \overline{CS} , $t_t(\overline{CS})$					10	μs
Operating free-air temperature, T_A	TLV1543C		0	70		$^{\circ}\text{C}$
	TLV1543M		-55	125		

- NOTES: 2. Analog input voltages greater than that applied to REF+ convert as all ones (1111111111), while input voltages less than that applied to REF- convert as all zeros (0000000000). The device is functional with reference voltages down to 1 V ($V_{ref+} - V_{ref-}$); however, the electrical specifications are no longer applicable.
3. To minimize errors caused by noise at \overline{CS} , the internal circuitry waits for a setup time plus two falling edges of the internal system clock after $\overline{CS}\downarrow$ before responding to control input signals. No attempt should be made to clock in an address until the minimum \overline{CS} setup time has elapsed.
4. For 11- to 16-bit transfers, after the tenth I/O CLOCK falling edge ($\leq 2\text{ V}$), at least one I/O clock rising edge ($\geq 2\text{ V}$) must occur within 9.5 μs .
5. This is the time required for the clock input signal to fall from V_{IHmin} to V_{ILmax} or to rise from V_{ILmax} to V_{IHmin} . In the vicinity of normal room temperature, the devices function with input clock transition time as slow as 1 μs for remote data-acquisition applications where the sensor and the A/D converter are placed several feet away from the controlling microprocessor.

勝特力材料 886-3-5753170
 勝特力电子(上海) 86-21-54151736
 勝特力电子(深圳) 86-755-83298787
[Http://www.100y.com.tw](http://www.100y.com.tw)



TLV1543C, TLV1543M
3.3-V 10-BIT ANALOG-TO-DIGITAL CONVERTERS
WITH SERIAL CONTROL AND 11 ANALOG INPUTS

SLAS072C – DECEMBER 1992 – REVISED MARCH 1995

electrical characteristics over recommended operating free-air temperature range,
 $V_{CC} = V_{ref+} = 3\text{ V to }5.5\text{ V}$, I/O CLOCK frequency = 1.1 MHz for the TLV1543C,
 $V_{CC} = V_{ref+} = 3\text{ V to }3.6\text{ V}$, I/O CLOCK frequency = 2.1 MHz for the TLV1543M (unless otherwise noted)

PARAMETER		TEST CONDITIONS	MIN	TYP†	MAX	UNIT
V_{OH} High-level output voltage	TLV1543C	$V_{CC} = 3\text{ V}$, $I_{OH} = -1.6\text{ mA}$	2.4			V
		$V_{CC} = 3\text{ V to }5.5\text{ V}$, $I_{OH} = 20\text{ }\mu\text{A}$	$V_{CC}-0.1$			V
	TLV1543M	$V_{CC} = 3\text{ V}$, $I_{OH} = -1.6\text{ mA}$	2.4			V
		$V_{CC} = 3\text{ V to }3.6\text{ V}$, $I_{OH} = 20\text{ }\mu\text{A}$	$V_{CC}-0.1$			V
V_{OL} Low-level output voltage	TLV1543C	$V_{CC} = 3\text{ V}$, $I_{OL} = 1.6\text{ mA}$			0.4	V
		$V_{CC} = 3\text{ V to }5.5\text{ V}$, $I_{OL} = 20\text{ }\mu\text{A}$			0.1	V
	TLV1543M	$V_{CC} = 3\text{ V}$, $I_{OL} = 1.6\text{ mA}$			0.4	V
		$V_{CC} = 3\text{ V to }3.6\text{ V}$, $I_{OL} = 20\text{ }\mu\text{A}$			0.1	V
I_{OZ} Off-state (high-impedance-state) output current	$V_O = V_{CC}$, \overline{CS} at V_{CC}				10	μA
	$V_O = 0$, \overline{CS} at V_{CC}				-10	μA
I_{IH} High-level input current	$V_I = V_{CC}$			0.005	2.5	μA
I_{IL} Low-level input current	$V_I = 0$			-0.005	-2.5	μA
I_{CC} Operating supply current	\overline{CS} at 0 V			0.8	2.5	mA
Selected channel leakage current		Selected channel at V_{CC} , Unselected channel at 0 V			1	μA
		Selected channel at 0 V, Unselected channel at V_{CC}			-1	μA
Maximum static analog reference current into REF +		$V_{ref+} = V_{CC}$, $V_{ref-} = \text{GND}$			10	μA
C_i	Input capacitance, Analog inputs	TLV1543C		7	55	pF
		TLV1543M		7		
	Input capacitance, Control inputs	TLV1543C		5	15	pF
		TLV1543M		5		

† All typical values are at $V_{CC} = 5\text{ V}$, $T_A = 25^\circ\text{C}$.

勝特力材料 886-3-5753170
勝特力电子(上海) 86-21-54151736
勝特力电子(深圳) 86-755-83298787
[Http://www.100y.com.tw](http://www.100y.com.tw)



TLV1543C, TLV1543M

3.3-V 10-BIT ANALOG-TO-DIGITAL CONVERTERS

WITH SERIAL CONTROL AND 11 ANALOG INPUTS

SLAS072C – DECEMBER 1992 – REVISED MARCH 1995

operating characteristics over recommended operating free-air temperature range,
 $V_{CC} = V_{ref+} = 3\text{ V to }5.5\text{ V}$, I/O CLOCK frequency = 1.1 MHz for the TLV1543C,
 $V_{CC} = V_{ref+} = 3\text{ V to }3.6\text{ V}$, I/O CLOCK frequency = 2.1 MHz for the TLV1543M

PARAMETER	TEST CONDITIONS	MIN	TYP†	MAX	UNIT
Linearity error (see Note 6)				±1	LSB
Zero error (see Note 7)	See Note 2			±1	LSB
Full-scale error (see Note 7)	See Note 2			±1	LSB
Total unadjusted error (see Note 8)				±1	LSB
Self-test output code (see Table 3 and Note 9)	ADDRESS = 1011		512		
	ADDRESS = 1100		0		
	ADDRESS = 1101		1023		
t_{conv} Conversion time	See Figures 9–14			21	μs
t_c Total cycle time (access, sample, and conversion)	See Figures 9–14 and Note 10			21 +10 I/O CLOCK periods	μs
t_{acq} Channel acquisition time (sample)	See Figures 9–14 and Note 10			6	I/O CLOCK periods
t_v Valid time, DATA OUT remains valid after I/O CLOCK↓	See Figure 6	10			ns
$t_d(I/O\text{-}DATA)$ Delay time, I/O CLOCK↓ to DATA OUT valid	See Figure 6			240	ns
$t_d(I/O\text{-}EOC)$ Delay time, tenth I/O CLOCK↓ to EOC↓	See Figure 7		70	240	ns
$t_d(EOC\text{-}DATA)$ Delay time, EOC↑ to DATA OUT (MSB)	See Figure 8			100	ns
t_{PZH}, t_{PZL} Enable time, \overline{CS} ↓ to DATA OUT (MSB driven)	See Figure 3			1.3	μs
t_{PHZ}, t_{PLZ} Disable time, \overline{CS} ↑ to DATA OUT (high impedance)	See Figure 3			150	ns
$t_r(EOC)$ Rise time, EOC	See Figure 8			300	ns
$t_f(EOC)$ Fall time, EOC	See Figure 7			300	ns
$t_r(\text{bus})$ Rise time, data bus	See Figure 6			300	ns
$t_f(\text{bus})$ Fall time, data bus	See Figure 6			300	ns
$t_d(I/O\text{-}CS)$ Delay time, tenth I/O CLOCK↓ to \overline{CS} ↓ to abort conversion (see Note 11)				9	μs

† All typical values are at $T_A = 25^\circ\text{C}$.

- NOTES:
- Analog input voltages greater than that applied to REF+ convert as all ones (111111111), while input voltages less than that applied to REF− convert as all zeros (000000000). The device is functional with reference voltages down to 1 V ($V_{ref+} - V_{ref-}$); however, the electrical specifications are no longer applicable.
 - Linearity error is the maximum deviation from the best straight line through the A/D transfer characteristics.
 - Zero-scale error is the difference between 000000000 and the converted output for zero input voltage; full-scale error is the difference between 111111111 and the converted output for full-scale input voltage.
 - Total unadjusted error comprises linearity, zero-scale, and full-scale errors.
 - Both the input address and the output codes are expressed in positive logic.
 - I/O CLOCK period = 1/(I/O CLOCK frequency) (see Figure 6).
 - Any transitions of \overline{CS} are recognized as valid only if the level is maintained for a setup time plus two falling edges of the internal clock (1.425 μs) after the transition.

勝特力材料 886-3-5753170
 勝特力电子(上海) 86-21-54151736
 勝特力电子(深圳) 86-755-83298787
[Http://www.100y.com.tw](http://www.100y.com.tw)



PARAMETER MEASUREMENT INFORMATION

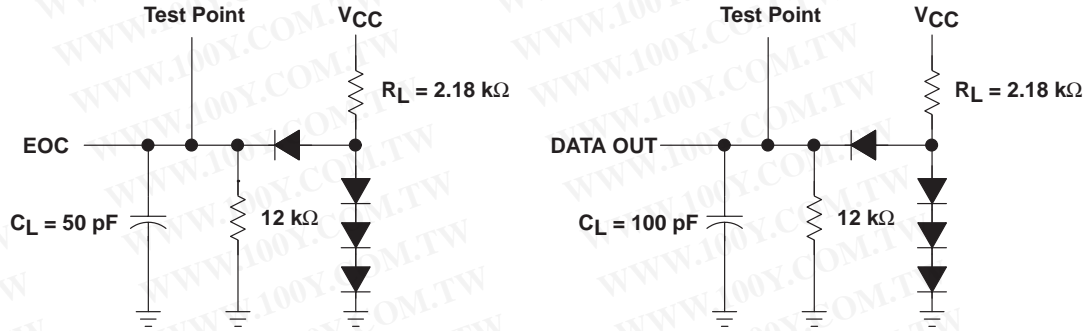

Figure 2. Load Circuits

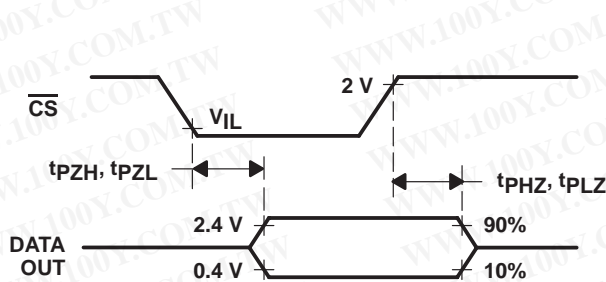

Figure 3. DATA OUT to Hi-Z Voltage Waveforms

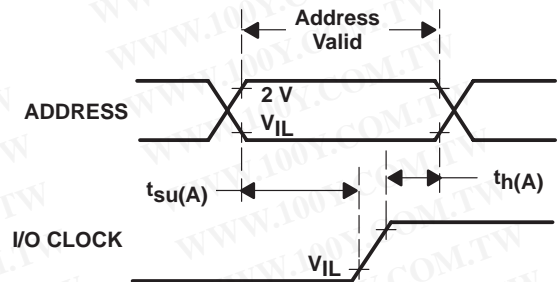

Figure 4. ADDRESS Setup Voltage Waveforms

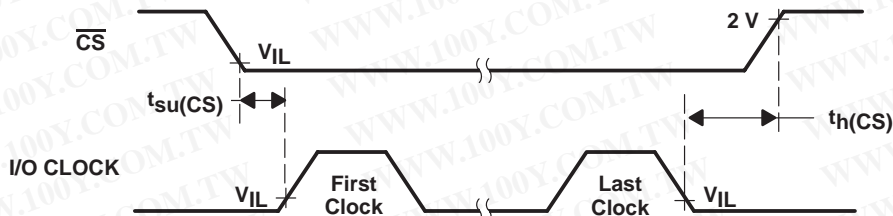

Figure 5. \overline{CS} and I/O CLOCK Voltage Waveforms

勝特力材料 886-3-5753170
 勝特力电子(上海) 86-21-54151736
 勝特力电子(深圳) 86-755-83298787
[Http://www.100y.com.tw](http://www.100y.com.tw)

PARAMETER MEASUREMENT INFORMATION

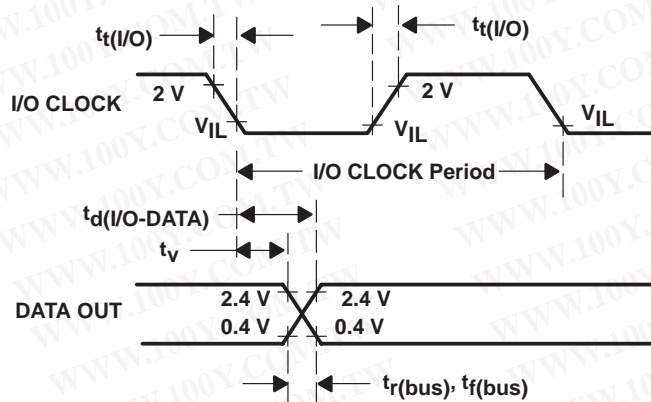

Figure 6. DATA OUT and I/O CLOCK Voltage Waveforms

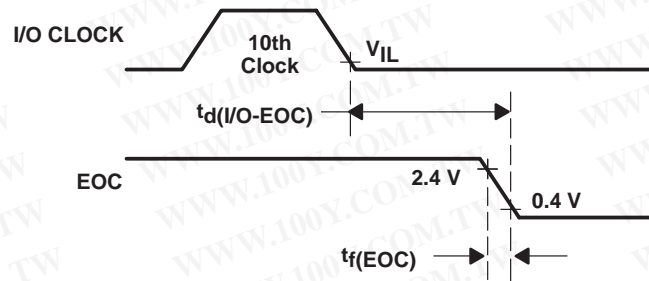

Figure 7. I/O CLOCK and EOC Voltage Waveforms

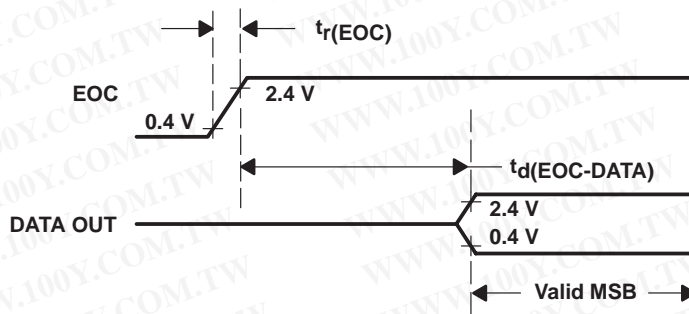
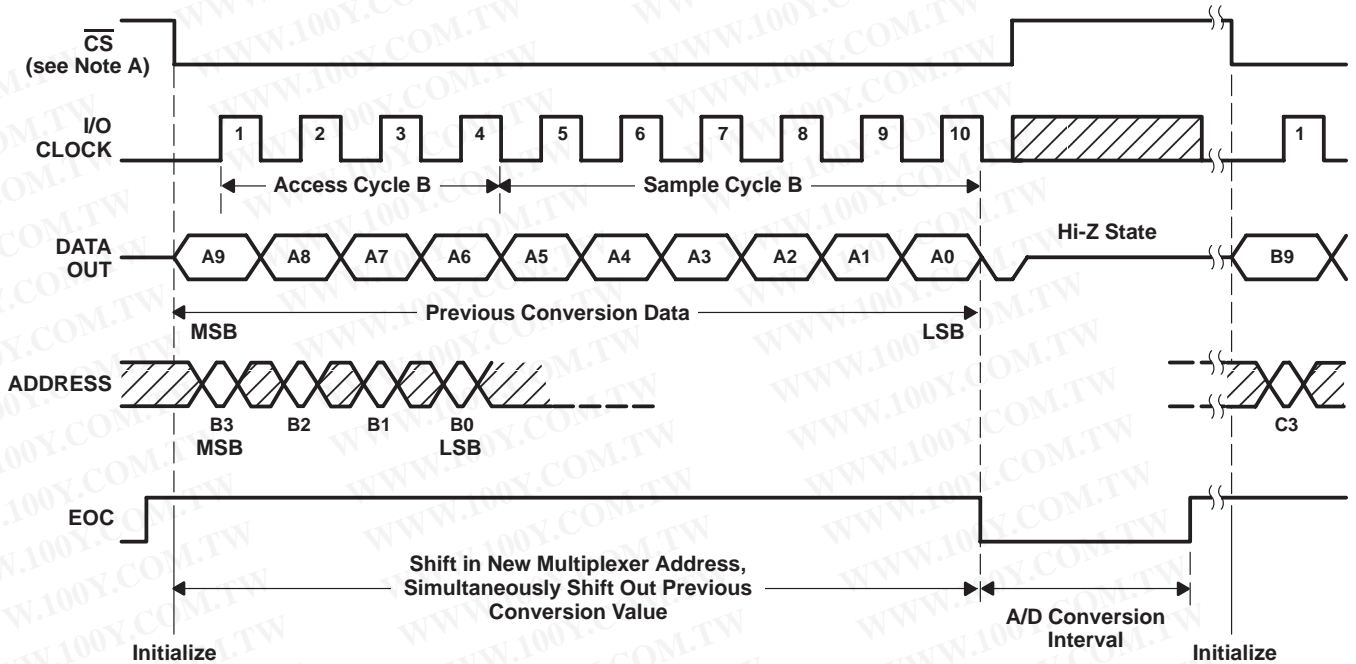

Figure 8. EOC and DATA OUT Voltage Waveforms

勝特力材料 886-3-5753170
 勝特力电子(上海) 86-21-54151736
 勝特力电子(深圳) 86-755-83298787
[Http://www.100y.com.tw](http://www.100y.com.tw)

TLV1543C, TLV1543M
3.3-V 10-BIT ANALOG-TO-DIGITAL CONVERTERS
WITH SERIAL CONTROL AND 11 ANALOG INPUTS

SLAS072C – DECEMBER 1992 – REVISED MARCH 1995



NOTE A: To minimize errors caused by noise at \overline{CS} , the internal circuitry waits for a setup time plus two falling edges of the internal system clock after $\overline{CS}\downarrow$ before responding to control input signals. No attempt should be made to clock in an address until the minimum CS setup time has elapsed.

Figure 9. Timing for 10-Clock Transfer Using \overline{CS}

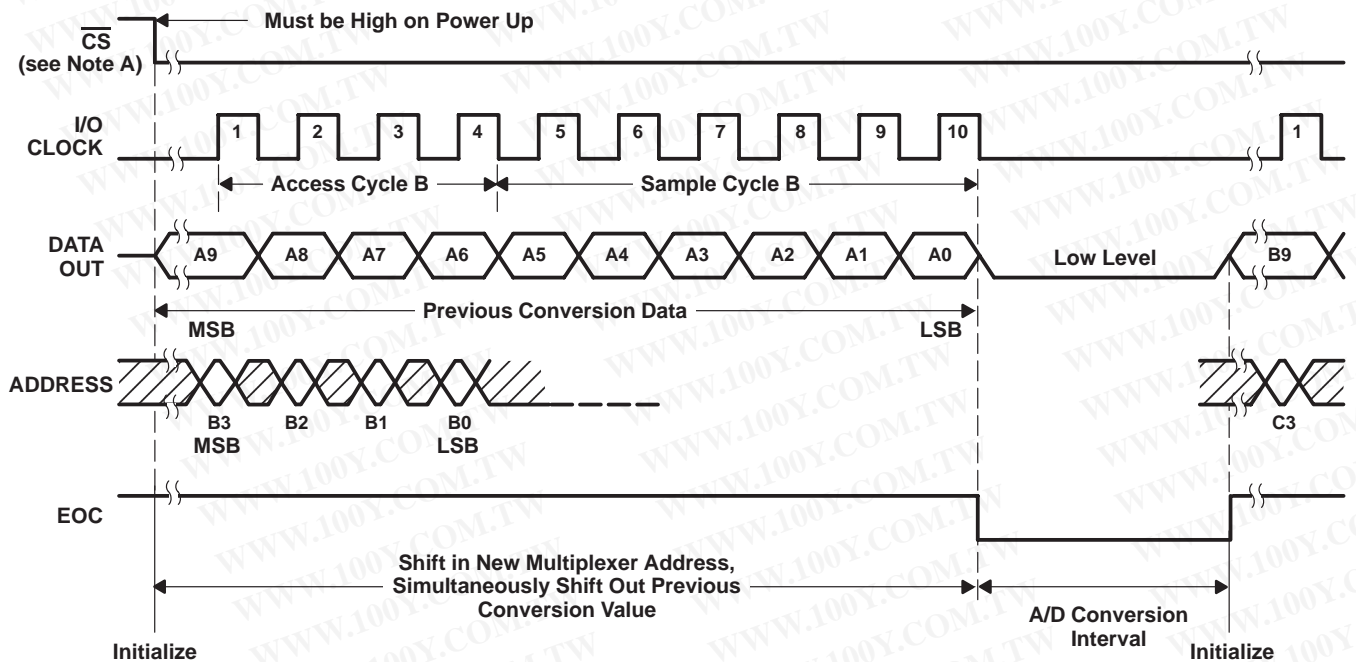

NOTE A: To minimize errors caused by noise at \overline{CS} , the internal circuitry waits for a setup time plus two falling edges of the internal system clock after $\overline{CS}\downarrow$ before responding to control input signals. No attempt should be made to clock in an address until the minimum CS setup time has elapsed.

Figure 10. Timing for 10-Clock Transfer Not Using \overline{CS}

勝特力材料 886-3-5753170
 勝特力电子(上海) 86-21-54151736
 勝特力电子(深圳) 86-755-83298787
[Http://www.100y.com.tw](http://www.100y.com.tw)



POST OFFICE BOX 655303 • DALLAS, TEXAS 75265

TLV1543C, TLV1543M
3.3-V 10-BIT ANALOG-TO-DIGITAL CONVERTERS
WITH SERIAL CONTROL AND 11 ANALOG INPUTS

SLAS072C – DECEMBER 1992 – REVISED MARCH 1995

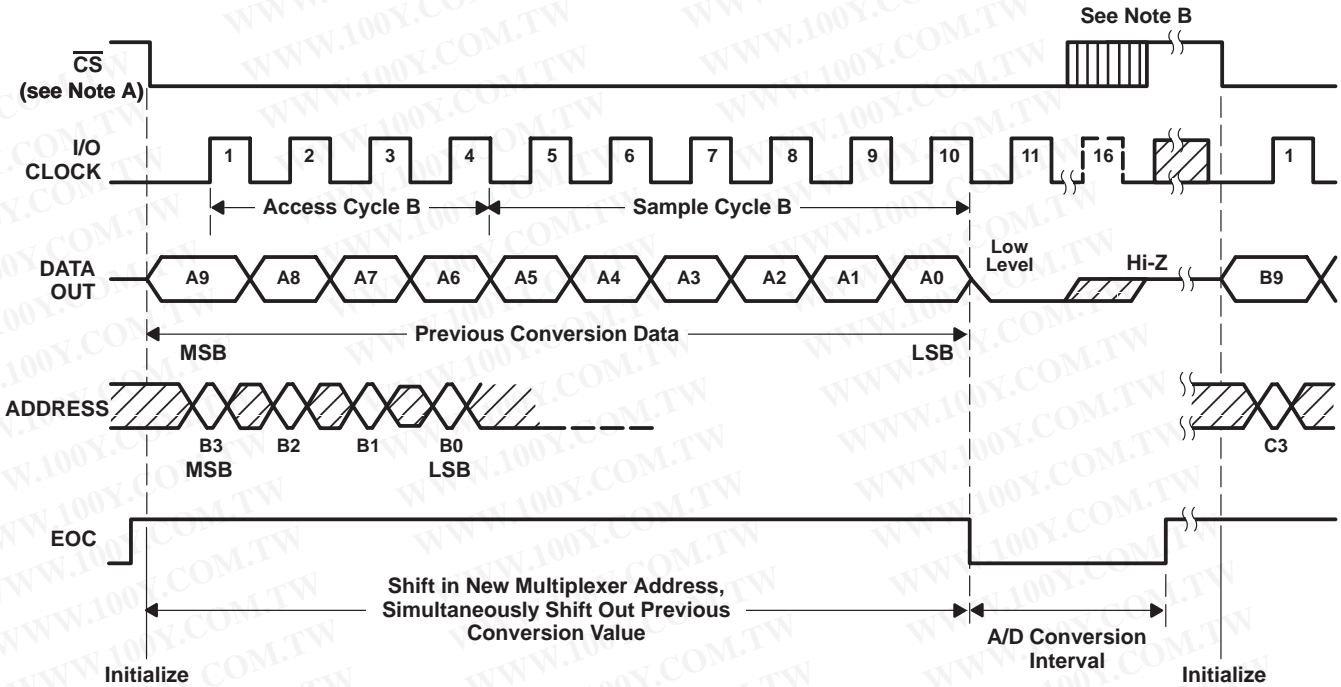

- NOTES: A. To minimize errors caused by noise at \overline{CS} , the internal circuitry waits for a set up time plus two falling edges of the internal system clock after $\overline{CS}\downarrow$ before responding to control input signals. No attempt should be made to clock in an address until the minimum \overline{CS} setup time has elapsed.
- B. A low-to-high transition of \overline{CS} disables ADDRESS and the I/O CLOCK within a maximum of a setup time plus two falling edges of the internal system clock.

Figure 11. Timing for 11- to 16-Clock Transfer Using \overline{CS} (Serial Transfer Interval Shorter Than Conversion)

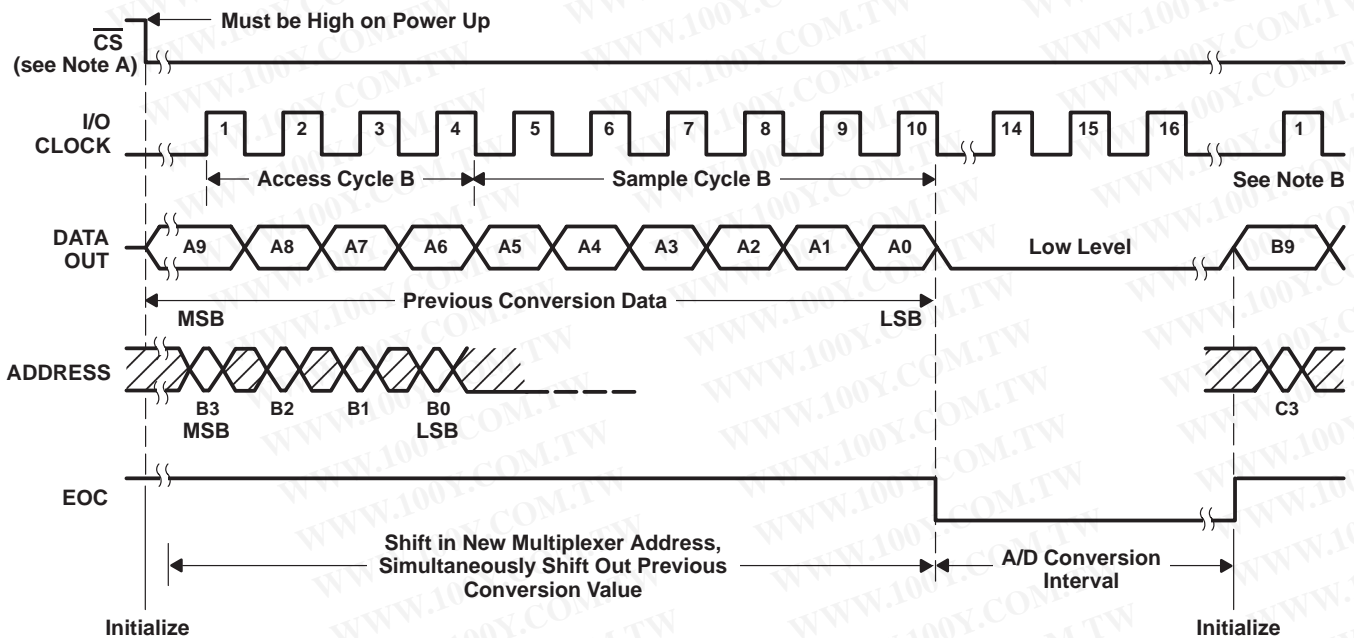

- NOTES: A. The first I/O CLOCK must occur after the rising edge of EOC.
- B. A low-to-high transition of \overline{CS} disables ADDRESS and the I/O CLOCK within a maximum of a setup time plus two falling edges of the internal system clock.

Figure 12. Timing for 16-Clock Transfer Not Using \overline{CS} (Serial Transfer Interval Shorter Than Conversion)



POST OFFICE BOX 655303 • DALLAS, TEXAS 75265

勝特力材料 886-3-5753170
 勝特力电子(上海) 86-21-54151736
 勝特力电子(深圳) 86-755-83298787
[Http://www.100y.com.tw](http://www.100y.com.tw)

TLV1543C, TLV1543M
3.3-V 10-BIT ANALOG-TO-DIGITAL CONVERTERS
WITH SERIAL CONTROL AND 11 ANALOG INPUTS

SLAS072C – DECEMBER 1992 – REVISED MARCH 1995

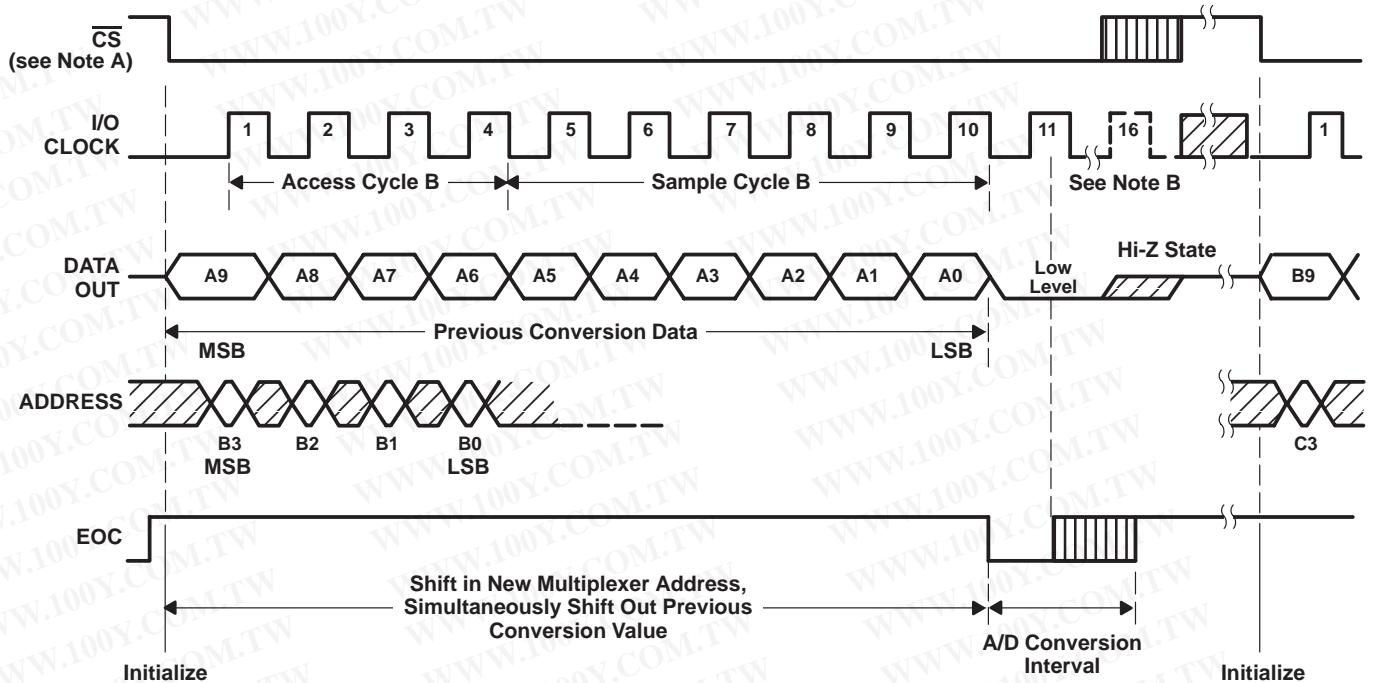

- NOTES: A. To minimize errors caused by noise at \overline{CS} , the internal circuitry waits for a set up time plus two falling edges of the internal system clock after $\overline{CS}\downarrow$ before responding to control input signals. No attempt should be made to clock in an address until the minimum chip \overline{CS} setup time has elapsed.
- B. The eleventh rising edge of the I/O CLOCK sequence must occur before the conversion is complete to prevent losing serial interface synchronization.

Figure 13. Timing for 11- to 16-Clock Transfer Using \overline{CS} (Serial Transfer Interval Longer Than Conversion)

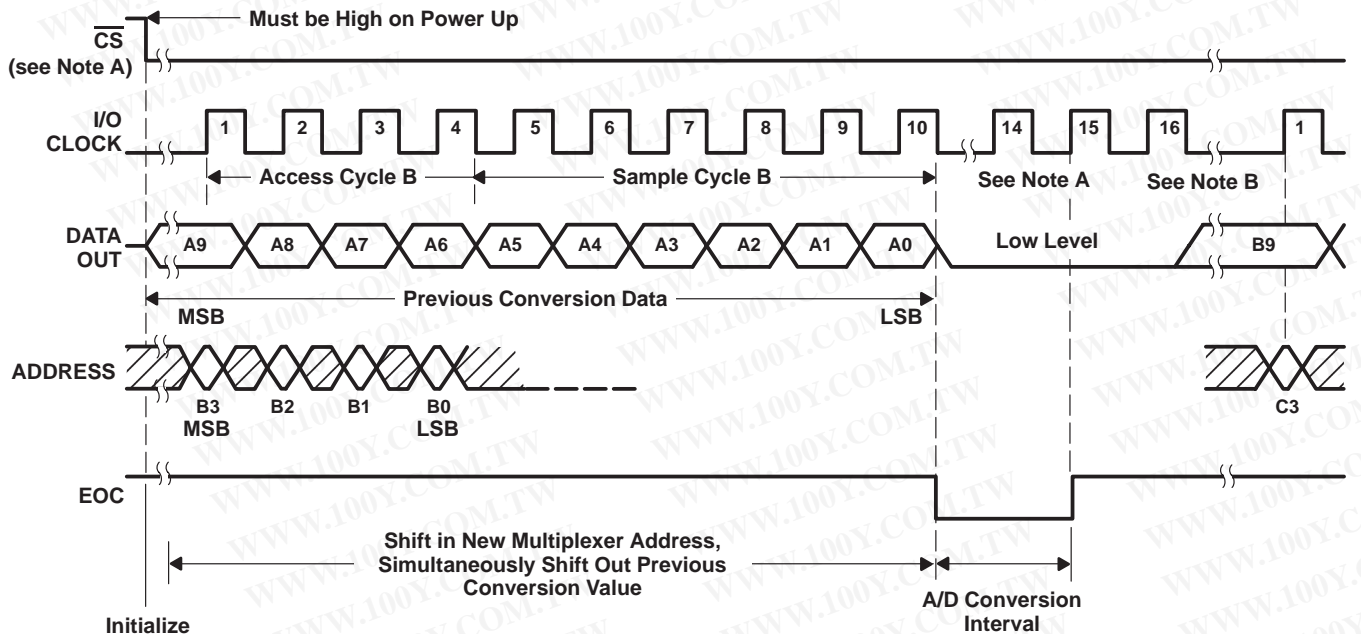

- NOTES: A. The eleventh rising edge of the I/O CLOCK sequence must occur before the conversion is complete to prevent losing serial interface synchronization.
- B. The I/O CLOCK sequence is exactly 16 clock pulses long.

Figure 14. Timing for 16-Clock Transfer Not Using \overline{CS} (Serial Transfer Interval Longer Than Conversion)

勝特力材料 886-3-5753170
 勝特力电子(上海) 86-21-54151736
 勝特力电子(深圳) 86-755-83298787
[Http://www.100y.com.tw](http://www.100y.com.tw)



POST OFFICE BOX 655303 • DALLAS, TEXAS 75265

TLV1543C, TLV1543M
3.3-V 10-BIT ANALOG-TO-DIGITAL CONVERTERS
WITH SERIAL CONTROL AND 11 ANALOG INPUTS

SLAS072C – DECEMBER 1992 – REVISED MARCH 1995

APPLICATION INFORMATION

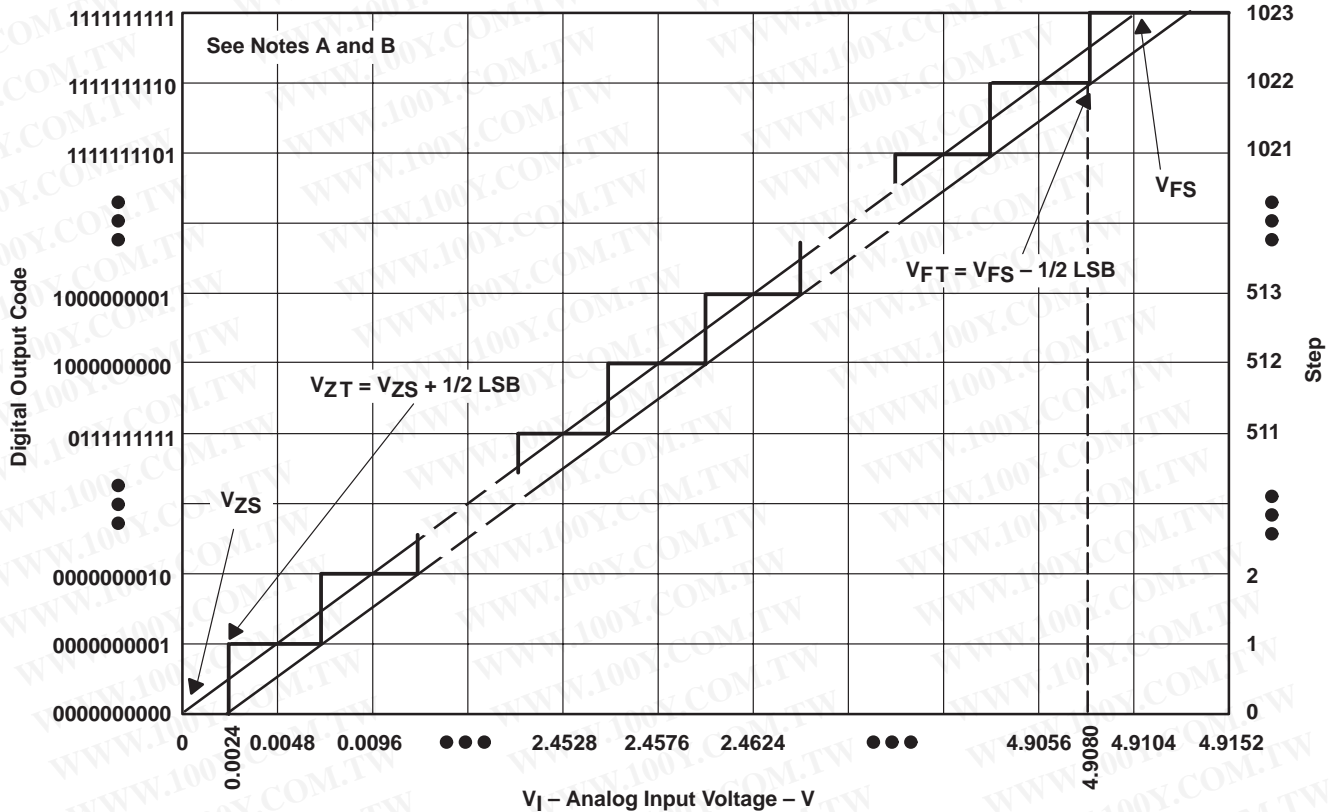

- NOTES: A. This curve is based on the assumption that V_{ref+} and V_{ref-} have been adjusted so that the voltage at the transition from digital 0 to 1 (V_{ZT}) is 0.0024 V and the transition to full scale (V_{FT}) is 4.908 V. 1 LSB = 4.8 mV.
- B. The full-scale value (V_{FS}) is the step whose nominal midstep value has the highest absolute value. The zero-scale value (V_{ZS}) is the step whose nominal midstep value equals zero.

Figure 15. Ideal Conversion Characteristics

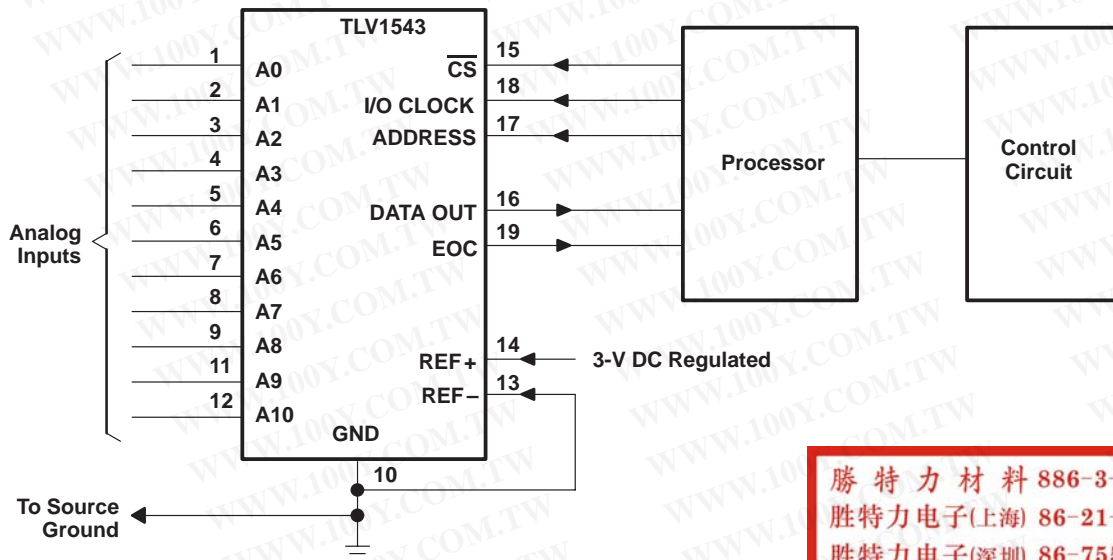

Figure 16. Serial Interface

勝特力材料 886-3-5753170
 勝特力电子(上海) 86-21-54151736
 勝特力电子(深圳) 86-755-83298787
[Http://www.100y.com.tw](http://www.100y.com.tw)



APPLICATION INFORMATION

simplified analog input analysis

Using the equivalent circuit in Figure 17, the time required to charge the analog input capacitance from 0 to V_S within 1/2 LSB can be derived as follows:

The capacitance charging voltage is given by

$$V_C = V_S \left(1 - e^{-t_c/R_t C_i}\right) \quad (1)$$

where

$$R_t = R_S + r_i$$

The final voltage to 1/2 LSB is given by

$$V_C (1/2 \text{ LSB}) = V_S - (V_S/2048) \quad (2)$$

Equating equation 1 to equation 2 and solving for time t_c gives

$$V_S - (V_S/2048) = V_S \left(1 - e^{-t_c/R_t C_i}\right) \quad (3)$$

and

$$t_c (1/2 \text{ LSB}) = R_t \times C_i \times \ln(2048) \quad (4)$$

Therefore, with the values given the time for the analog input signal to settle is

$$t_c (1/2 \text{ LSB}) = (R_S + 1 \text{ k}\Omega) \times 60 \text{ pF} \times \ln(2048) \quad (5)$$

This time must be less than the converter sample time shown in the timing diagrams.

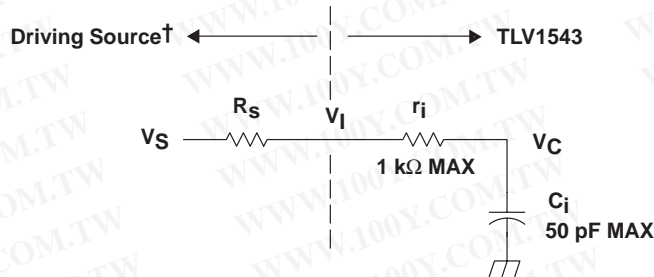

V_I = Input Voltage at A0–A10
 V_S = External Driving Source Voltage
 R_S = Source Resistance
 r_i = Input Resistance
 C_i = Input Capacitance

† Driving source requirements:

- Noise and distortion for the source must be equivalent to the resolution of the converter.
- R_S must be real at the input frequency.

Figure 17. Equivalent Input Circuit Including the Driving Source

勝特力材料 886-3-5753170
 勝特力电子(上海) 86-21-54151736
 勝特力电子(深圳) 86-755-83298787
[Http://www.100y.com.tw](http://www.100y.com.tw)

IMPORTANT NOTICE

Texas Instruments and its subsidiaries (TI) reserve the right to make changes to their products or to discontinue any product or service without notice, and advise customers to obtain the latest version of relevant information to verify, before placing orders, that information being relied on is current and complete. All products are sold subject to the terms and conditions of sale supplied at the time of order acknowledgement, including those pertaining to warranty, patent infringement, and limitation of liability.

TI warrants performance of its semiconductor products to the specifications applicable at the time of sale in accordance with TI's standard warranty. Testing and other quality control techniques are utilized to the extent TI deems necessary to support this warranty. Specific testing of all parameters of each device is not necessarily performed, except those mandated by government requirements.

CERTAIN APPLICATIONS USING SEMICONDUCTOR PRODUCTS MAY INVOLVE POTENTIAL RISKS OF DEATH, PERSONAL INJURY, OR SEVERE PROPERTY OR ENVIRONMENTAL DAMAGE ("CRITICAL APPLICATIONS"). TI SEMICONDUCTOR PRODUCTS ARE NOT DESIGNED, AUTHORIZED, OR WARRANTED TO BE SUITABLE FOR USE IN LIFE-SUPPORT DEVICES OR SYSTEMS OR OTHER CRITICAL APPLICATIONS. INCLUSION OF TI PRODUCTS IN SUCH APPLICATIONS IS UNDERSTOOD TO BE FULLY AT THE CUSTOMER'S RISK.

In order to minimize risks associated with the customer's applications, adequate design and operating safeguards must be provided by the customer to minimize inherent or procedural hazards.

TI assumes no liability for applications assistance or customer product design. TI does not warrant or represent that any license, either express or implied, is granted under any patent right, copyright, mask work right, or other intellectual property right of TI covering or relating to any combination, machine, or process in which such semiconductor products or services might be or are used. TI's publication of information regarding any third party's products or services does not constitute TI's approval, warranty or endorsement thereof.

勝特力材料 886-3-5753170
胜特力电子(上海) 86-21-54151736
胜特力电子(深圳) 86-755-83298787
[Http://www.100y.com.tw](http://www.100y.com.tw)

Copyright © 1998, Texas Instruments Incorporated