

TC9148P

FOR INFRARED REMOTE CONTROL TRANSMITTER.

The TC9148P is C-MOS LSI developed for use on the infrared remote control transmitter.

This LSI has 18 functions, and total 75 commands can be transmitted : 63 commands by the continuous keys of multiple keying is possible and 12 commands by the single shot keys.

- Wide Range of Operating Supply Voltage Allows Low Voltage Operation ($V_{DD}=2.2\sim 5.0V$)
- C-MOS Structure Assures Extremely Low Power Dissipation.
- Multiple Keying is Possible (Max. Sextet).
- Less External Parts
- Adaptable to other Models as Code Bits are Available
- An Oscillator can be Constructed only by Connecting an LC or Ceramic Resonator as the Oscillation Circuit is Housed.

Unit in mm

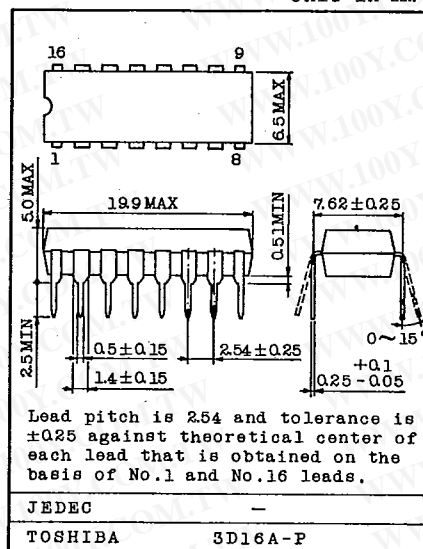

Lead pitch is 2.54 and tolerance is ± 0.25 against theoretical center of each lead that is obtained on the basis of No.1 and No.16 leads.

勝特力材料 886-3-5753170
 勝特力电子(上海) 86-21-54151736
 勝特力电子(深圳) 86-755-83298787
[Http://www.100y.com.tw](http://www.100y.com.tw)

MAXIMUM RATINGS ($T_a=25^{\circ}C$)

CHARACTERISTIC	SYMBOL	RATING	UNIT
Supply Voltage	V_{DD}	6.0	V
Input/Output Voltage	V_{IN}	$V_{SS}-0.3\sim V_{DD}+0.3$	V
Power Dissipation	P_D	200	mW
Operating Temperature	T_{opr}	$-20\sim 75$	$^{\circ}C$
Storage Temperature	T_{stg}	$-55\sim 125$	$^{\circ}C$
T_XOUT Output Current	I_{OUT}	-5	mA

PIN CONNECTION

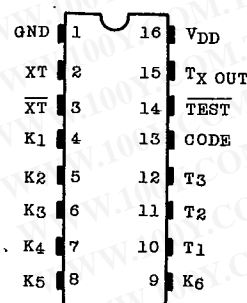
**TOSHIBA**

勝特力材料 886-3-5753170
 勝特力电子(上海) 86-21-54151736
 勝特力电子(深圳) 86-755-83298787
 Http://www.100y.com.tw

TC9148P

T-77-11

BLOCK DIAGRAM

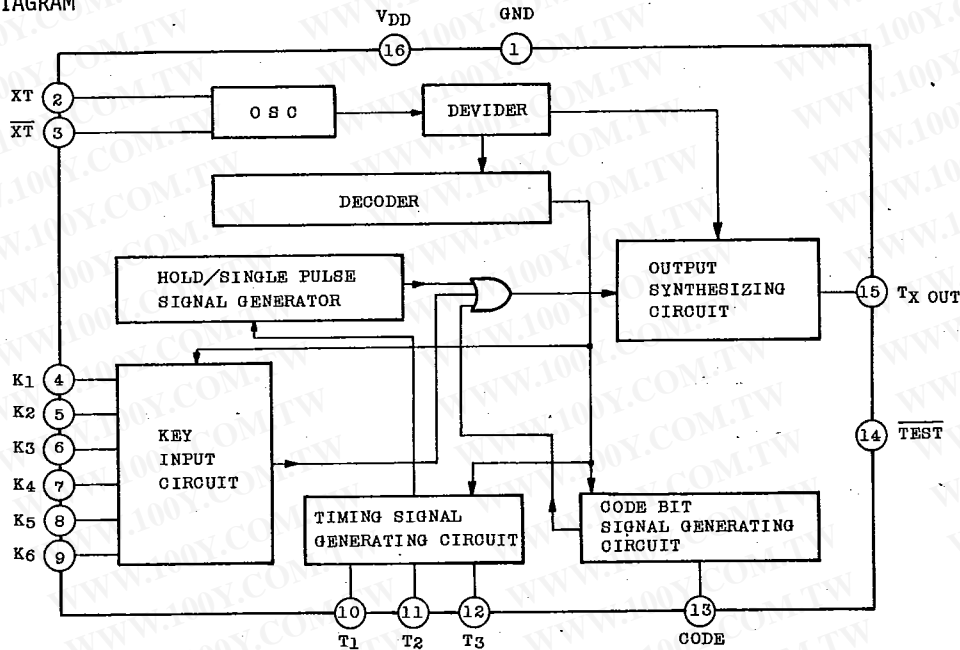

DESCRIPTION OF TERMINALS

PIN No.	SYMBOL	TERMINAL	FUNCTION / OPERATION
1, 16	GND, V _{DD}	GND/Power	Supply Voltage Terminal
2, 3	XT, \overline{XT}	Terminal for OSC	Terminal for OSC, and used for connecting a 455kHz ceramic resonator etc. (with a built-in feedback resistor)
4~9	K ₁ ~K ₆	Key Input Terminal	Key input terminal for Key matrix. 18 keys can be connected at T ₁ ~T ₃ ×K ₁ ~K ₆ (with a built-in pull-down resistor)
10~12	T ₁ ~T ₃	Timing Signal Output Terminal	Digit timing output terminal for Key matrix.
13	CODE	Code bit Input Terminal	Terminal for matching code between transmitting and receiving.
14	\overline{TEST}	Test Terminal	Keep this terminal open.
15	T _X OUT	Transmitting Output Terminal	Transmitting signal output. Modulation is made by 12 bits 1 cycle and 38kHz carrier wave.

AUDIO DIGITAL IC

TC9148P

T-77-11

勝特力材料 886-3-5753170
 勝特力电子(上海) 86-21-54151736
 勝特力电子(深圳) 86-755-83298787
[Http://www.100y.com.tw](http://www.100y.com.tw)

ELECTRICAL CHARACTERISTICS (Unless otherwise specified, $V_{DD}=3.0V$, $T_a=25^{\circ}C$)

CHARACTERISTIC			SYMBOL	TEST CIR-CUIT	TEST CONDITION	MIN.	TYP.	MAX.	UNIT	
Operating Supply Voltage			V_{DD}	-	All Function Operation	2.2	-	5.0	V	
Operating Supply Current			I_{DD}	-	Key ON, Without Load	-	-	1.0	mA	
Quiescent Current Consumption			I_{DS}	-	All Key OFF, Stop of OSC	-	-	10	μA	
Input Terminal	K1 ~ K6 CODE	Input Voltage	"H" Level	V_{IH}	-	-	2.0	-	3.0	V
			"L" Level	V_{IL}	-	-	0	-	0.5	V
	K1 ~ K6	Input Current	"H" Level	I_{IH}	-	$V_{IH}=3.0V$	20	30	60	μA
			"L" Level	I_{IL}	-	$V_{IL}=0V$	-1.0	-	1.0	μA
	CODE TEST	Input Current	"H" Level	I_{IH}	-	$V_{IH}=3.0V$	-1.0	-	1.0	μA
			"L" Level	I_{IL}	-	$V_{IL}=0V$	20	30	60	μA
Output Terminal	T1 ~ T3	Output Current	"H" Level	I_{OH}	-	$V_{OH}=2.0V$	-500	-	-	μA
			"L" Level	I_{OL}	-	$V_{OL}=3.0V$	50	-	-	μA
	Tx	Output Current	"H" Level	I_{OH}	-	$V_{OH}=2.0V$	-0.1	-	-	mA
			"L" Level	I_{OL}	-	$V_{OL}=2.0V$	1.0	-	-	mA
OSC Feedback Resistor			R_f	-	-	-	500	-	k Ω	
Oscillation Frequency			f_{OSC}	-	-	400	455	600	kHz	

勝特力材料 886-3-5753170
 勝特力电子(上海) 86-21-54151736
 勝特力电子(深圳) 86-755-83298787
 Http://www.100y.com.tw

TC9148P

T-77-11

FUNCTIONAL DESCRIPTION

1. OSCILLATION CIRCUIT

As the self-bias type amplifier by means of C-MOS inverter has been housed, the oscillation circuit can be constructed when an LC or ceramic resonator is connected.

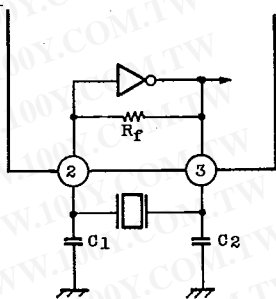

CERAMIC RESONATOR
 KBR-455B
 KYOCERA Co. Ltd
 OR EQUIVALENT
 $C_1, C_2 = 50 \sim 150 \text{ pF}$

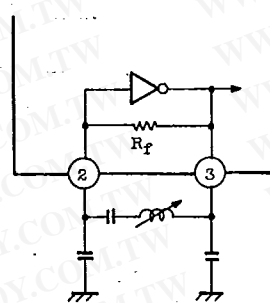

When oscillation frequency is set at 455kHz, carrier wave of transmitting signal is set at 38kHz, oscillation of the oscillation circuit is kept stopped unless the keys are operated, thus reducing power consumption.

2. KEY INPUT

18 keys can be connected by Key input $K_1 \sim K_6$ and 6×3 matrix by means of timing signal $T_1 \sim T_3$.

Multiple keying is possible for the keys connected to T_1 line up to sextet, and all key inputs are output. (Output becomes continuous pulses.)

Between the timing signal lines, priority has been decided in order of T_1 , T_2 and T_3 . The keys connected to T_2 and T_3 lines have priority and input is made through more than 2 keys, single signal is preferentially output in order of $K_1 \sim K_6$.

Further, the keys connected to T_2 and T_3 lines are for single signals and no second signal is transmitted unless input is made again after the key is released once.

AUDIO DIGITAL IC

TC9148P

T-77-11

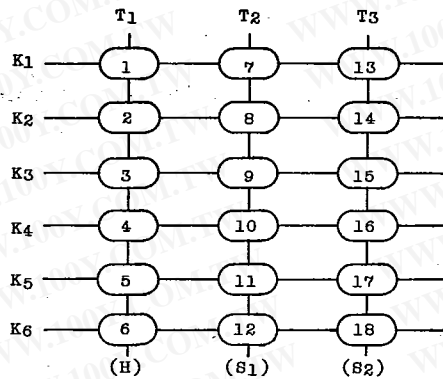

勝特力材料 886-3-5753170
 勝特力电子(上海) 86-21-54151736
 勝特力电子(深圳) 86-755-83298787
[Http://www.100y.com.tw](http://www.100y.com.tw)

KEY MATRIX

- Key No.1~6

Continuous key output with it pressed, and multiple keying is possible.

- Key No.7~18

These keys are the single-shot keys and when input is made, signal is output only one time.

3. TRANSMISSION COMMAND

Transmission command is in one word 12-bits configuration.

C1~C3 are code bits adaptable to many models, H, S1 and S2 are continuous signal and single-shot signal codes, and D1~D6 are Key Input data codes in 6-bits.

C1	C2	C3	H	S1	S2	D1	D2	D3	D4	D5	D6
----	----	----	---	----	----	----	----	----	----	----	----

CODE BIT

CONTINUOUS/
SINGLE-SHOT
CODE

KEY INPUT CODE

勝特力材料 886-3-5753170
 勝特力电子(上海) 86-21-54151736
 勝特力电子(深圳) 86-755-83298787
[Http://www.100y.com.tw](http://www.100y.com.tw)

TC9148P

T-77-11

4. DATA CODE

KEY No.	DATA										OUTPUT FORM	KEY No.	DATA										OUTPUT FORM
	H	S1	S2	D1	D2	D3	D4	D5	D6	H			S1	S2	D1	D2	D3	D4	D5	D6			
1	1	0	0	1	0	0	0	0	0	0	CONTINUOUS	10	0	1	0	0	0	0	1	0	0	SINGLE-SHOT	
2	1	0	0	0	1	0	0	0	0	0	"	11	0	1	0	0	0	0	0	1	0	"	
3	1	0	0	0	0	1	0	0	0	0	"	12	0	1	0	0	0	0	0	0	1	"	
4	1	0	0	0	0	0	1	0	0	0	"	13	0	0	1	1	0	0	0	0	0	"	
5	1	0	0	0	0	0	0	1	0	0	"	14	0	0	1	0	1	0	0	0	0	"	
6	1	0	0	0	0	0	0	0	1	0	"	15	0	0	1	0	0	1	0	0	0	"	
7	0	1	0	1	0	0	0	0	0	0	SINGLE-SHOT	16	0	0	1	0	0	0	1	0	0	"	
8	0	1	0	0	1	0	0	0	0	0	"	17	0	0	1	0	0	0	0	1	0	"	
9	0	1	0	0	0	1	0	0	0	0	"	18	0	0	1	0	0	0	0	0	1	"	

As the multiple keying is possible, Key No. 1~6 are capable of output 63 commands through a combination of D1~D6 data.

Key No. 7~18 are the single-shot keys for output 12 commands, and 75 commands can be output through a combination of continuous key (multiple keying is possible) and Single-Shot key.

TC9148P

T-77-11

5. CODE BITS (C₁, C₂, C₃)

Code bit can be made at one terminal with diodes connected through T₁~T₃ timing terminals.

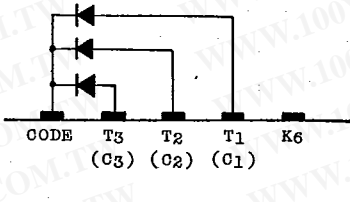

勝特力材料 886-3-5753170
 勝特力电子(上海) 86-21-54151736
 勝特力电子(深圳) 86-755-83298787
[Http://www.100y.com.tw](http://www.100y.com.tw)

Data of C₁, C₂ and C₃ code bit become "1" when diodes are connected to CODE Terminal through Timing Signal. Terminals T₁~T₃, and "0" when not connected. (In the above diagram, C₁, C₂ and C₃ are 1, 1 and 1 data.)

The TC9148P has 3 code bits. However, the TC9149P that is a receiving IC (DIP 16 PIN) and the TC9150P (DIP 24 PIN) are able to use only C₂ and C₃, and C₁ and C₂ 2 code bits, respectively. Therefore, diodes must be connected so that code bit data of the TC9148P agreement with the receiving IC.

CODE BIT	
C ₁	C ₂
C ₃	C ₂
1	0
0	1
1	1

C₁, C₂ TC9150P

C₂, C₃ TC9149P

* CODE BIT, "0", "0" CANNOT BE USED.

Note. For C₃ and C₁ code bit data not used on the TC9150P and TC9149P, it is necessary to transmit "1" and diodes must be so connected.

TC9148P

T-77-11

6. TRANSMITTING WAVEFORM

6.1 BASIC TRANSMITTING WAVEFORM (at $f_{OSC}=455kHz$)

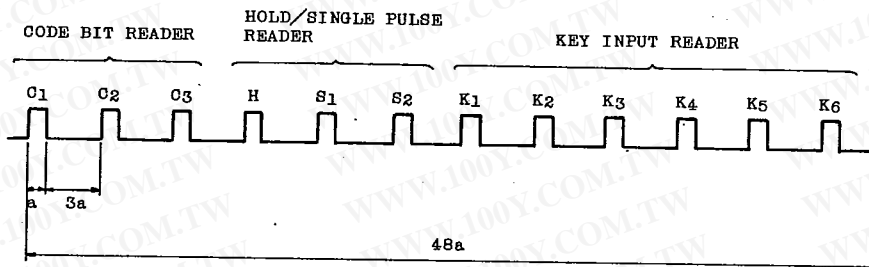

Basic transmitting waveform is 12-bits serial data in configuration as shown above.

The time of each bit "a" is decided as shown below by oscillation frequency f_{osc} by means of X_T and \bar{X}_T .

$$a = (1/f_{osc}) \times 192 \text{ (sec)}$$

6.2 DISTINCTION OF BIT "0" AND "1"

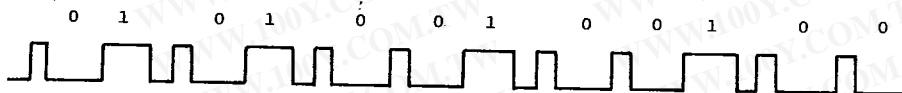
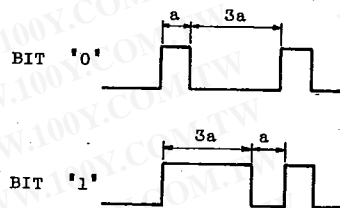

One word of the above transmission command is in the configuration of (010100100100).

勝特力材料 886-3-5753170
 勝特力电子(上海) 86-21-54151736
 勝特力电子(深圳) 86-755-83298787
[Http://www.100y.com.tw](http://www.100y.com.tw)

TC9148P

T-77-11

勝特力材料 886-3-5753170
 勝特力电子(上海) 86-21-54151736
 勝特力电子(深圳) 86-755-83298787
[Http://www.100y.com.tw](http://www.100y.com.tw)

6.3 SINGLE-SHOT SIGNAL

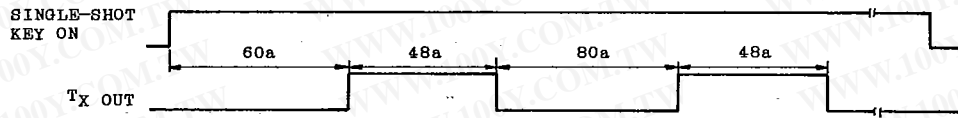

When any one of the single-shot keys is depressed, the above single-shot signal is transmitted in 2 cycles, and the transmitting output ends.

6.4 CONTINUOUS SIGNAL

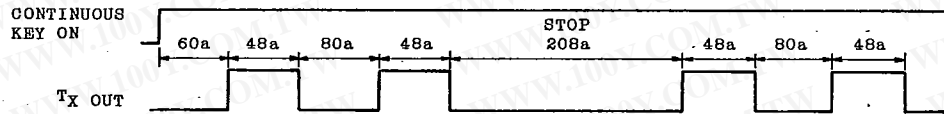

When any one of the continuous keys is depressed, the above continuous signal is 2 cycles output, repeatedly output 208a pause and 2 cycles output is 2 pause of 208a.

6.5 CARRIER WAVE

About 50~100mA current is normally applied through an infrared LED in order to extend an infrared ray reaching distance. Therefore, if a time when LED is ON is shortened as could as possible, it leads to reduction in power consumption. On this IC, when single-shot or continuous signal is transmitting, each bit is switching by a carrier of duty 1/3, output after the pulse modulated.

Carrier (f_c) is decided by oscillation frequency f_{osc} by means of X_T and \bar{X}_T .

$$f_c = \frac{f_{osc}}{12} (\text{Hz}) \quad f_c \approx 38\text{kHz} \quad \text{at } f_{osc} = 455\text{kHz}$$

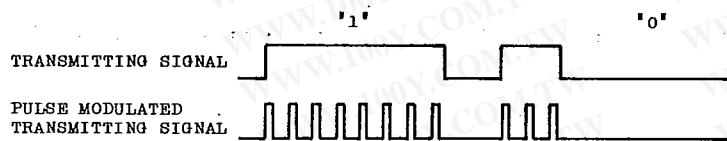

TC9148P

T-77-11

APPLICATION CIRCUIT

勝特力材料 886-3-5753170
 勝特力电子(上海) 86-21-54151736
 勝特力电子(深圳) 86-755-83298787
[Http://www.100y.com.tw](http://www.100y.com.tw)

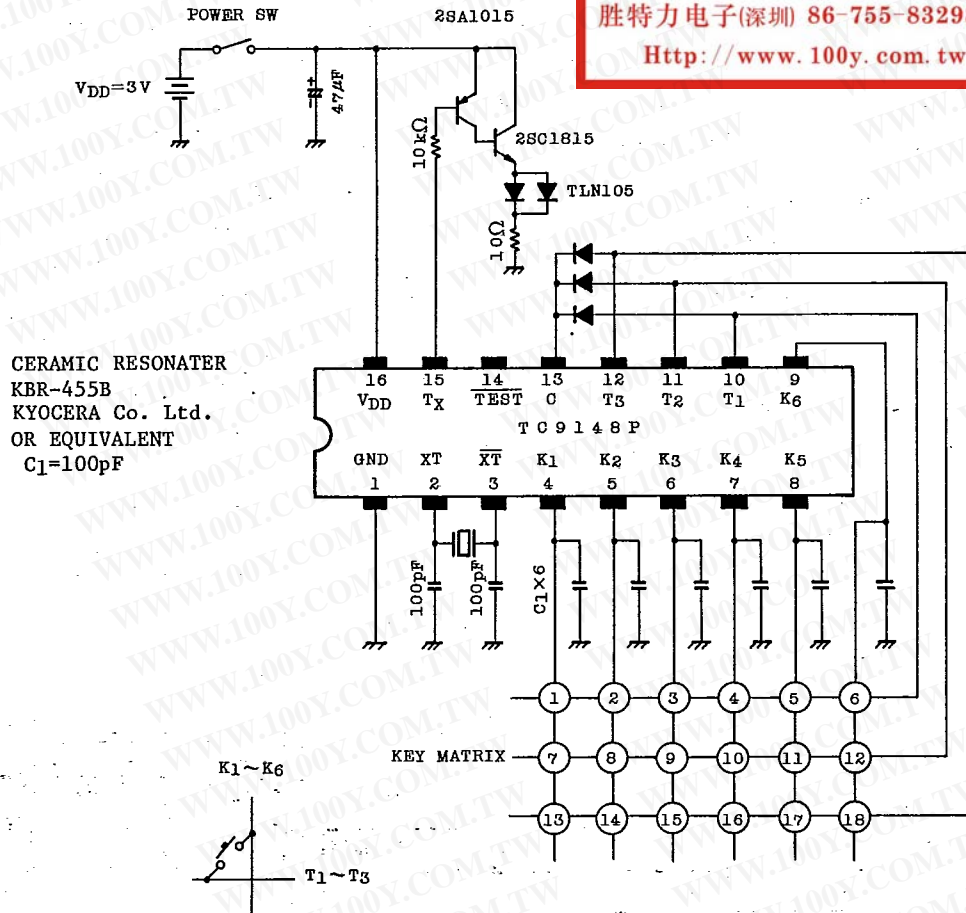

AUDIO DIGITAL IC