



TRP

勝特力材料 886-3-5753170
 勝特力电子(上海) 86-21-34970699
 勝特力电子(深圳) 86-755-83298787
[Http://www.100y.com.tw](http://www.100y.com.tw)

MAIN FEATURES

- Subminiature, PCB Mounting.
- Heavy Duty, Silver Alloy Contacts up to 30A or 45A.
- 1 Form A, 1 Form B or 1 Form C.
- Two different spacing arrangements of terminals are available to meet the world standards.
- Used for Automotives, Industrial Control. Household Appliances and Heavy Loads, etc.

TYPICAL APPLICATIONS IN AUTOMOTIVE INDUSTRY

- | | | |
|---------------------------|----------------------------|-------------------------------|
| • Direction Indicators | • Air Conditioning | • Car alarm system |
| • Interval Wipers Control | • Central door lock | • Initial value control |
| • Fuel Pump Control | • Anti-lock braking system | • Automatic mirror adjustment |
| • Ventilation Motor | • Self tension adjustment | • Sliding roof |
| • Hazard Lights | • Window lifter | • Rear Window Heating |
| • Heater Control | • Seat positioning | • Flashes or turning signals |

ORDERING INFORMATION

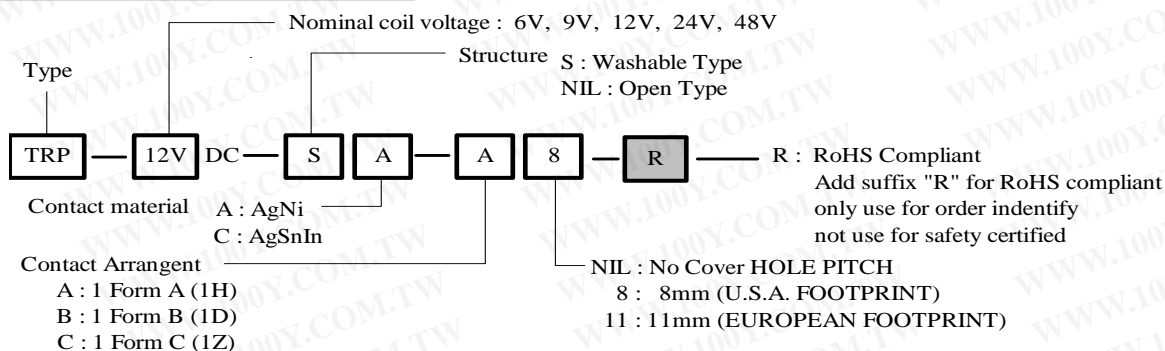

DIMENSION (unit:mm) DRILLING (unit:mm) WIRING DIAGRAM

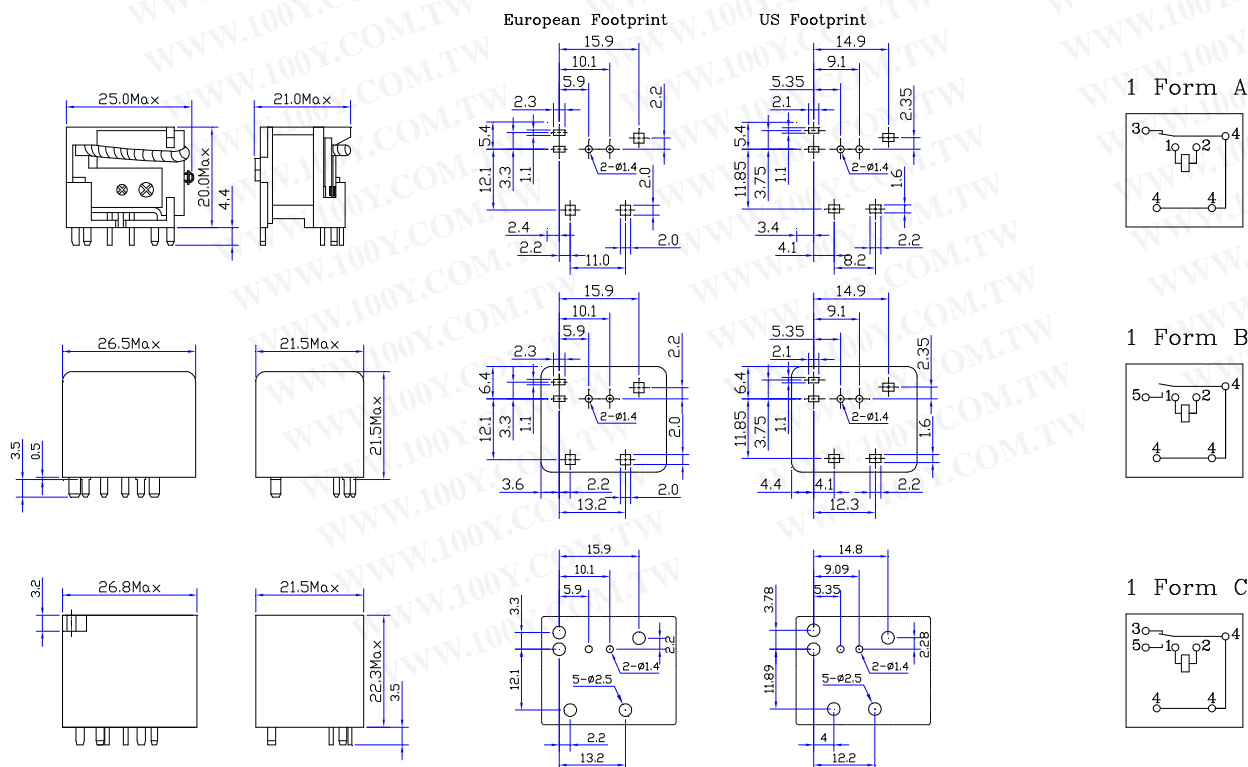

Remark: 1.In case of no tolerance shown in dimension: ±0.5mm.
 2.The tolerance without indicating for DRILLING is always ±0.1mm.

➤ COIL DATA CHART(at 20°C)

Coil Sensitivity	Coil Voltage Code	Nominal Voltage (VDC)	Nominal Current (mA)	Coil Resistance (Ω) ±10%	Power Consumption (W)	Pull-In Voltage (VDC)	Drop-Out Voltage (VDC)	Max-Allowable Voltage (VDC)
TRP	06	6	315	19	abt. 1.6 ~ 1.9	60% Max.	10% Min.	160%
	12	12	136	90				
	24	24	67	360				

➤ CONTACT RATING

Item	Type	TRP			
		Form A (1H)	Form B (1D)	Form C (1Z)	
				N.O.	N.C.
Contact Rating Resistive		40A 15VDC 12A 60VAC			
Max. Continuous Current		45A	30A	45A	30A
Max. Make Current		100A	30A	100A	30A
Max. Break Current		60A	30A	60A	30A
Max. Switch Voltage		75VDC ; 60VAC			
Contact Material		Ag Alloy			

➤ PERFORMANCE (at initial value)

Item	Type	TRP
Contact Resistance		100mΩ Max.
Operate Time		5msec Max.
Release Time		3msec Max.
Dielectric Strength		500Vrms.
Insulation Resistance		100 MΩ Min. (AT 500VDC)
Operating Ambient Temperature		-40°C to +125°C (See Ambient Temperature carry -40°C to +155°C(No water condensation and no water drop)
Operating Humidity		98% RH at 20°C
Vibration Endurance		20 Hz to 200Hz Double Amplitude 1.5mm
Shock		150m/sec ² , 11ms
Life Expectancy		
Mechanically		1 × 10 ⁷ ops. Min. (no load)
Electrically		1 × 10 ⁵ ops. Min. (at rated coil voltage)
Weight		
NO COVER TYPE		abt. 18grs.
SEALED TYPE		abt. 22.5grs.

➤ REFERENCE DATA

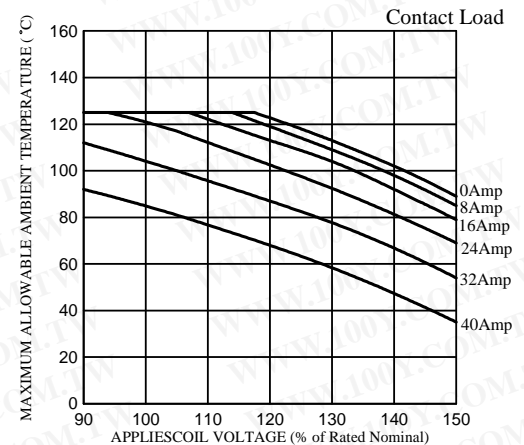
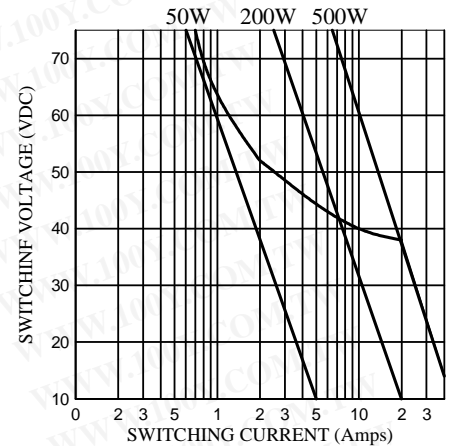

勝特力材料 886-3-5753170
胜特力电子(上海) 86-21-34970699
胜特力电子(深圳) 86-755-83298787
[Http://www.100y.com.tw](http://www.100y.com.tw)