



SGS-THOMSON
MICROELECTRONICS

TYN 0516 ---> TYN 816

勝特力材料 886-3-5753170
勝特力电子(上海) 86-21-54151736
勝特力电子(深圳) 86-755-83298787
[Http://www.100y.com.tw](http://www.100y.com.tw)

SCR

FEATURES

- HIGH SURGE CAPABILITY
- HIGH ON-STATE CURRENT
- HIGH STABILITY AND RELIABILITY

DESCRIPTION

The TYN 0516 ---> TYN 816 Family Silicon Controlled Rectifiers are high performance glass passivated chips technology. This general purpose Family Silicon Controlled Rectifiers is designed for power supply up to 400Hz on resistive or inductive load.

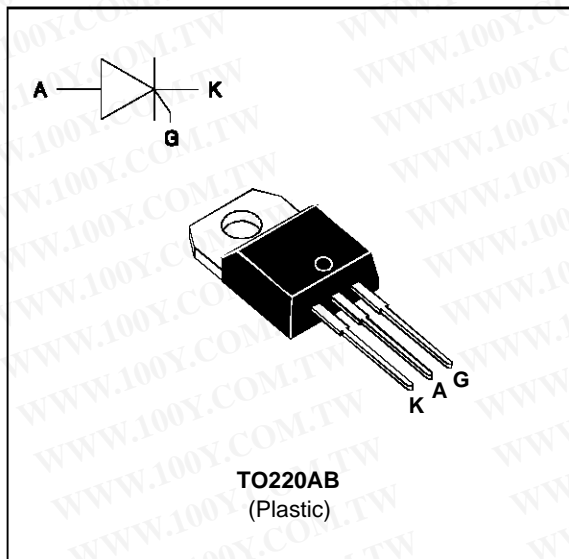

ABSOLUTE RATINGS (limiting values)

Symbol	Parameter	Value	Unit
$I_{T(RMS)}$	RMS on-state current (180° conduction angle)	$T_c = 95\text{ °C}$ 16	A
$I_{T(AV)}$	Average on-state current (180° conduction angle, single phase circuit)	$T_c = 95\text{ °C}$ 10	A
I_{TSM}	Non repetitive surge peak on-state current (T_j initial = 25°C)	$t_p = 8.3\text{ ms}$ 167	A
		$t_p = 10\text{ ms}$ 160	
I^2t	I^2t value	$t_p = 10\text{ ms}$ 128	A ² s
di/dt	Critical rate of rise of on-state current Gate supply : $I_G = 100\text{ mA}$ $di_G/dt = 1\text{ A}/\mu\text{s}$	100	A/ μs
T_{stg} T_j	Storage and operating junction temperature range	- 40 to + 150 - 40 to + 125	°C °C
T_I	Maximum lead temperature for soldering during 10 s at 4.5 mm from case	260	°C

Symbol	Parameter	TYN						Unit
		0516	116	216	416	616	816	
V_{DRM} V_{RRM}	Repetitive peak off-state voltage $T_j = 125\text{ °C}$	50	100	200	400	600	800	V

THERMAL RESISTANCES

Symbol	Parameter	Value	Unit
Rth (j-a)	Junction to ambient	60	°C/W
Rth (j-c) DC	Junction to case for DC	2.0	°C/W

GATE CHARACTERISTICS (maximum values)

$P_G (AV) = 1W$ $P_{GM} = 10W$ ($t_p = 20 \mu s$) $I_{FGM} = 4A$ ($t_p = 20 \mu s$) $V_{RGM} = 5V$.

ELECTRICAL CHARACTERISTICS

Symbol	Test Conditions	Value	Unit
I_{GT}	$V_D=12V$ (DC) $R_L=33\Omega$ $T_j=25^\circ C$ MAX	25	mA
V_{GT}	$V_D=12V$ (DC) $R_L=33\Omega$ $T_j=25^\circ C$ MAX	1.5	V
V_{GD}	$V_D=V_{DRM}$ $R_L=3.3k\Omega$ $T_j=125^\circ C$ MIN	0.2	V
tgt	$V_D=V_{DRM}$ $I_G = 90mA$ $dl_G/dt = 0.8A/\mu s$ $T_j=25^\circ C$ TYP	2	μs
I_L	$I_G=1.2 I_{GT}$ $T_j=25^\circ C$ TYP	70	mA
I_H	$I_T=100mA$ gate open $T_j=25^\circ C$ MAX	40	mA
V_{TM}	$I_{TM}=32A$ $t_p=380\mu s$ $T_j=25^\circ C$ MAX	1.6	V
I_{DRM} I_{RRM}	V_{DRM} Rated V_{RRM} Rated $T_j=25^\circ C$ MAX	0.01	mA
	$T_j=125^\circ C$	2	
dV/dt	Linear slope up to $V_D=67\%V_{DRM}$ gate open $T_j=125^\circ C$ MIN	500	V/ μs
tq	$V_D=67\%V_{DRM}$ $I_{TM}=32A$ $V_R=25V$ $dl_{TM}/dt=30 A/\mu s$ $dV_D/dt=50V/\mu s$ $T_j=125^\circ C$ TYP	70	μs

Fig.1 : Maximum average power dissipation versus average on-state current.

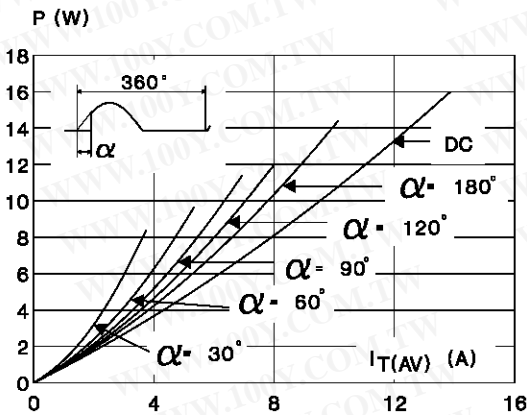

Fig.2 : Correlation between maximum average power dissipation and maximum allowable temperatures (T_{amb} and T_{case}) for different thermal resistances heatsink + contact.

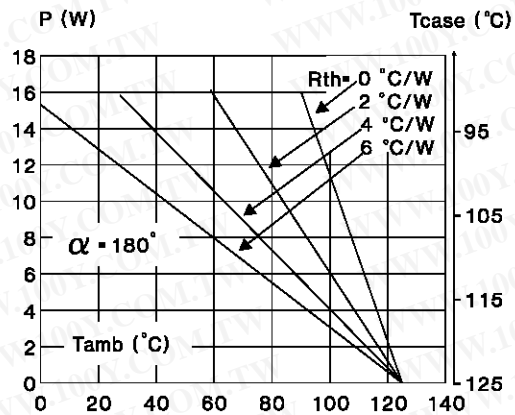

Fig.3 : Average on-state current versus case temperature.

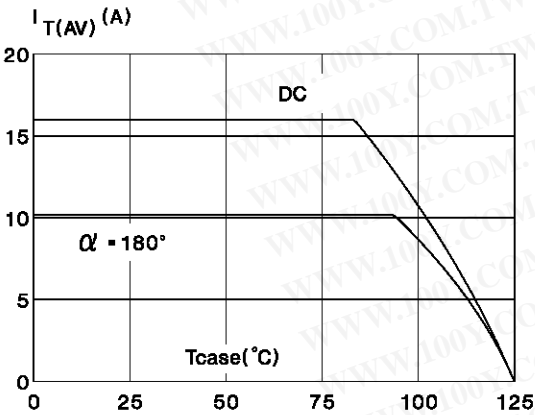

Fig.4 : Relative variation of thermal impedance versus pulse duration.

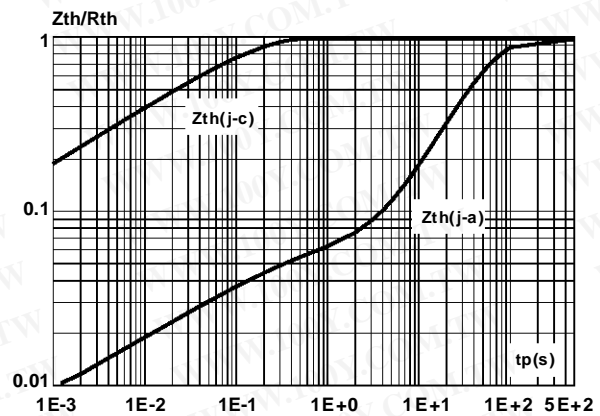

Fig.5 : Relative variation of gate trigger current versus junction temperature.

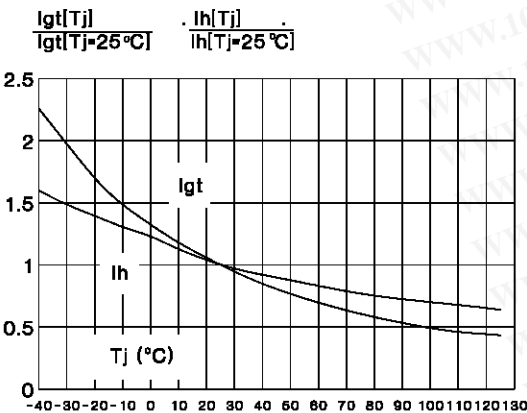
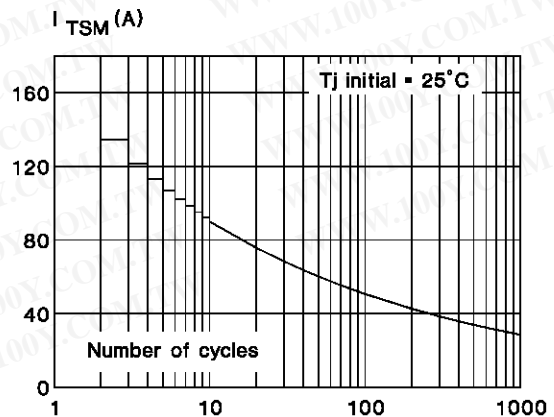

Fig.6 : Non repetitive surge peak on-state current versus number of cycles.



勝特力材料 886-3-5753170
 勝特力电子(上海) 86-21-54151736
 勝特力电子(深圳) 86-755-83298787
[Http://www.100y.com.tw](http://www.100y.com.tw)

TYN 0516 ---> TYN 816

Fig.7 : Non repetitive surge peak on-state current for a sinusoidal pulse with width : $t \leq 10$ ms, and corresponding value of I^2t .

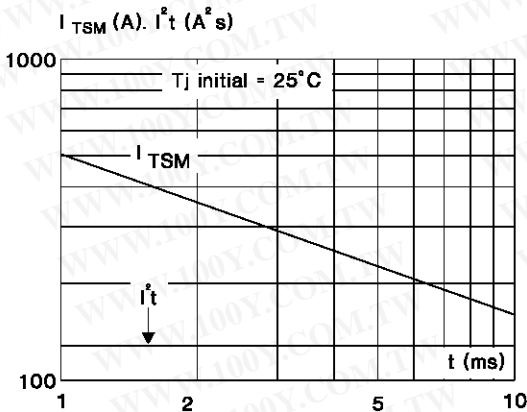
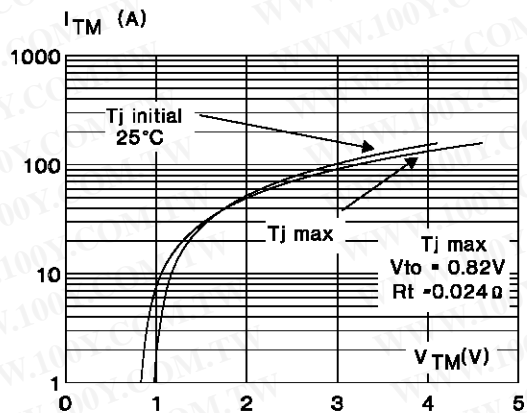
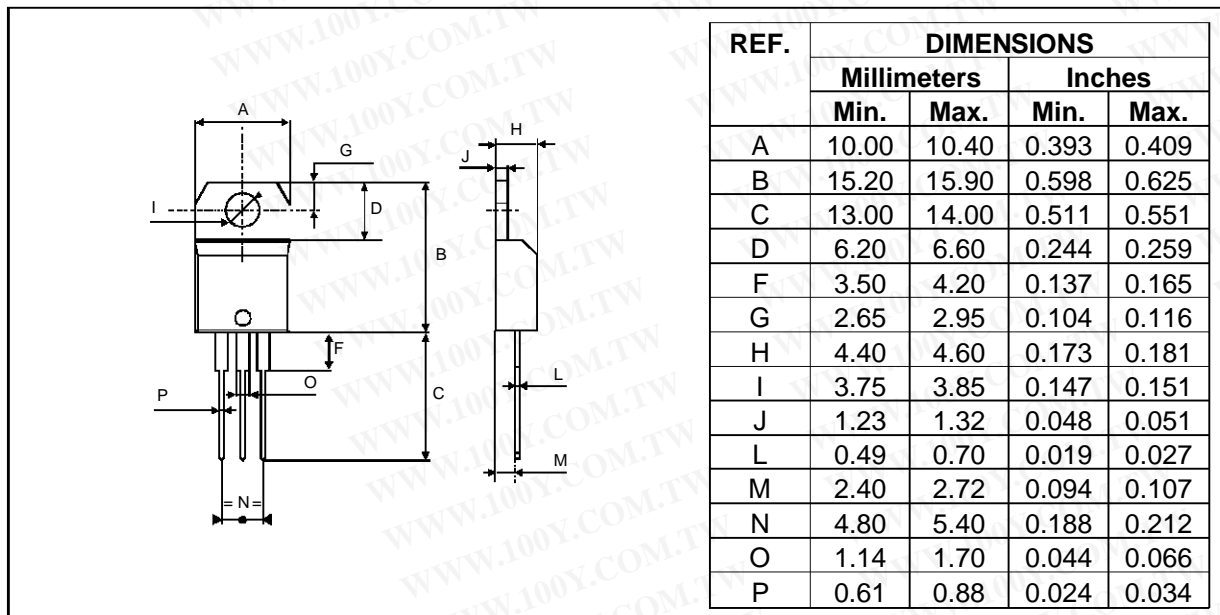

Fig.8 : On-state characteristics (maximum values).



PACKAGE MECHANICAL DATA

TO220AB Plastic



Cooling method : C
 Marking : type number
 Weight : 2.3 g

Recommended torque value : 0.8 m.N.
 Maximum torque value : 1 m.N.

Information furnished is believed to be accurate and reliable. However, SGS-THOMSON Microelectronics assumes no responsibility for the consequences of use of such information nor for any infringement of patents or other rights of third parties which may result from its use. No license is granted by implication or otherwise under any patent or patent rights of SGS-THOMSON Microelectronics. Specifications mentioned in this publication are subject to change without notice. This publication supersedes and replaces all information previously supplied.

SGS-THOMSON Microelectronics products are not authorized for use as critical components in life support devices or systems without express written approval of SGS-THOMSON Microelectronics.

© 1995 SGS-THOMSON Microelectronics - Printed in Italy - All rights reserved.
 SGS-THOMSON Microelectronics GROUP OF COMPANIES

Australia - Brazil - France - Germany - Hong Kong - Italy - Japan - Korea - Malaysia - Malta - Morocco - The Netherlands - Singapore - Spain - Sweden - Switzerland - Taiwan - Thailand - United Kingdom - U.S.A.