

VFC32

勝特力材料 886-3-5753170
勝特力电子(上海) 86-21-54151736
勝特力电子(深圳) 86-755-83298787
Http://www.100y.com.tw

Voltage-to-Frequency and Frequency-to-Voltage CONVERTER

FEATURES

- OPERATION UP TO 500kHz
- EXCELLENT LINEARITY
±0.01% max at 10kHz FS
±0.05% max at 100kHz FS
- V/F OR F/V CONVERSION
- MONOTONIC
- VOLTAGE OR CURRENT INPUT

APPLICATIONS

- INTEGRATING A/D CONVERTER
- SERIAL FREQUENCY OUTPUT
- ISOLATED DATA TRANSMISSION
- FM ANALOG SIGNAL MOD/DEMODO
- MOTOR SPEED CONTROL
- TACHOMETER

DESCRIPTION

The VFC32 voltage-to-frequency converter provides an output frequency accurately proportional to its input voltage. The digital open-collector frequency output is compatible with all common logic families. Its integrating input characteristics give the VFC32 excellent noise immunity and low nonlinearity.

Full-scale output frequency is determined by an external capacitor and resistor and can be scaled over a wide range. The VFC32 can also be configured as a frequency-to-voltage converter.

The VFC32 is available in 14-pin plastic DIP, SO-14 surface-mount, and metal TO-100 packages. Commercial, industrial, and military temperature range models are available.

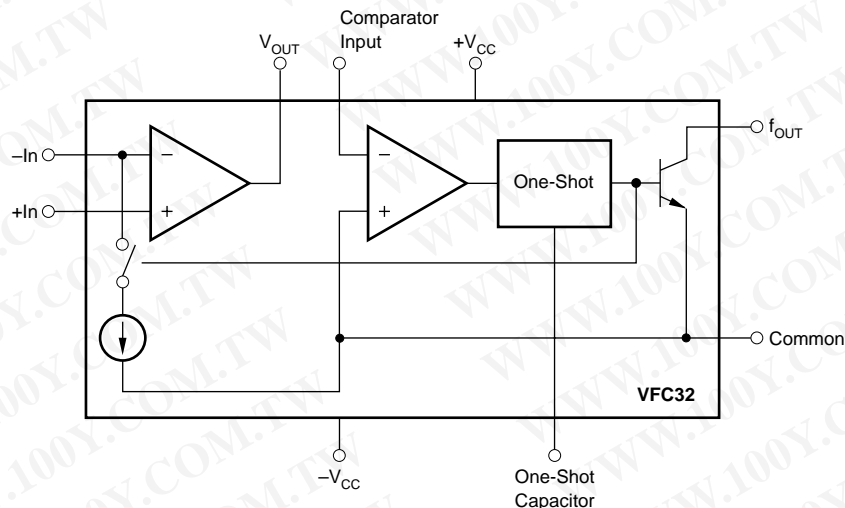

International Airport Industrial Park • Mailing Address: PO Box 11400 • Tucson, AZ 85734 • Street Address: 6730 S. Tucson Blvd. • Tucson, AZ 85706
Tel: (602) 746-1111 • Twx: 910-952-1111 • Cable: BBRCORP • Telex: 066-6491 • FAX: (602) 889-1510 • Immediate Product Info: (800) 548-6132

SPECIFICATIONS

At $T_A = +25^\circ\text{C}$ and $V_{CC} = \pm 15\text{V}$, unless otherwise noted.

PARAMETER	CONDITIONS	VFC32KP, KU			VFC32BM			VFC32SM			UNITS
		MIN	TYP	MAX	MIN	TYP	MAX	MIN	TYP	MAX	
INPUT (V/F CONVERTER) $F_{OUT} = V_{IN}/7.5 R_1 C_1$ Voltage Range ⁽¹⁾ Positive Input		>0		+0.25mA $\times R_1$	*		*	*		*	V
Negative Input		>0		-10	*		*	*		*	V
Current Range ⁽¹⁾ Bias Current		>0		+0.25	*		*	*		*	mA
Inverting Input			20	100		*	*		*	*	nA
Noninverting Input			100	250		*	*		*	*	nA
Offset Voltage ⁽²⁾			1	4		*	*		*	*	mV
Differential Impedance		300 10	650 10		*	*		*	*		k Ω pF
Common-mode Impedance		300 3	500 3		*	*		*	*		M Ω pF
INPUT (F/V CONVERTER) $V_{OUT} = 7.5 R_1 C_1 F_{IN}$ Impedance		50 10	150 10		*	*		*	*		k Ω pF
Logic "1"			+1.0		*		*	*		*	V
Logic "0"			-0.05		*		*	*		*	V
Pulse-width Range		0.1		150k/F _{MAX}	*		*	*		*	μs
ACCURACY Linearity Error ⁽³⁾	0.01Hz \leq Oper Freq \leq 10kHz		± 0.005	± 0.010 ⁽⁴⁾		*	*		*	*	% of FSR ⁽⁵⁾
	0.1Hz \leq Oper Freq \leq 100kHz		± 0.025	± 0.05		*	*		*	*	% of FSR
	0.5Hz \leq Oper Freq \leq 500kHz		± 0.05			*	*		*	*	% of FSR
Offset Error Input Offset Voltage ⁽²⁾			1	4		*	*		*	*	mV
Offset Drift ⁽⁶⁾			± 3			*	*		*	*	ppm of FSR/ $^\circ\text{C}$
Gain Error ⁽²⁾			5			*	*		*	*	% of FSR
Gain Drift ⁽⁶⁾	f = 10kHz		± 75			± 50	± 100		± 70	± 150	ppm/ $^\circ\text{C}$
Full Scale Drift (offset drift and gain drift) ^(6, 7)	f = 10kHz		± 75			± 50	± 100		± 70	± 150	ppm of FSR/ $^\circ\text{C}$
Power Supply Sensitivity	f = DC, $\pm V_{CC} = 12\text{VDC}$ to 18VDC			± 0.015			*			*	% of FSR/%
OUTPUT (V/F CONVERTER) (open collector output)											
Voltage, Logic "0"	$I_{SINK} = 8\text{mA}$	0	0.2	0.4	*	*	*	*	*	*	V
Leakage Current, Logic "1"	$V_O = 15\text{V}$		0.01	1.0		*	*		*	*	μA
Voltage, Logic "1"	External Pull-up Resistor Required (see Figure 4)			V_{PU}		*	*		*	*	V
Pulse Width	For Best Linearity		0.25/F _{MAX}			*	*		*	*	s
Fall Time	$I_{OUT} = 5\text{mA}$, $C_{LOAD} = 500\text{pF}$			400		*	*		*	*	ns
OUTPUT (F/V CONVERTER) V_{OUT}											
Voltage	$I_O \leq 7\text{mA}$	0 to +10			*		*		*	*	V
Current	$V_O \leq 7\text{VDC}$	+10			*		*		*	*	mA
Impedance	Closed Loop			1			*		*	*	Ω
Capacitive Load	Without Oscillation			100			*		*	*	pF
DYNAMIC RESPONSE											
Full Scale Frequency				500 ⁽⁸⁾	*		*		*	*	kHz
Dynamic Range		6			*		*		*	*	decades
Settling Time	(V/F) to Specified Linearity for a Full Scale Input Step < 50% Overload		⁽⁹⁾			*	*		*	*	
Overload Recovery			⁽⁹⁾			*	*		*	*	
POWER SUPPLY											
Rated Voltage			± 15								V
Voltage Range		± 11		± 20					*	*	V
Quiescent Current			± 5.5	± 6.0		*	*		*	*	mA
TEMPERATURE RANGE											
Specification		0		+70	-25		+85	-55		+125	$^\circ\text{C}$
Operating		-25		+85	-55		+125	-55		+125	$^\circ\text{C}$
Storage		-25		+85	-65		+150	-65		+150	$^\circ\text{C}$

* Specification the same as VFC32KP.

NOTES: (1) A 25% duty cycle (0.25mA input current) is recommended for best linearity. (2) Adjustable to zero. See Offset and Gain Adjustment section. (3) Linearity error is specified at any operating frequency from the straight line intersecting 90% of full scale frequency and 0.1% of full scale frequency. See Discussion of Specifications section. Above 200kHz, it is recommended all grades be operated below +85 $^\circ\text{C}$. (4) $\pm 0.015\%$ of FSR for negative inputs shown in Figure 5. Positive inputs are shown in Figure 1. (5) FSR = Full Scale Range (corresponds to full scale frequency and full scale input voltage). (6) Exclusive of external components' drift. (7) Positive drift is defined to be increasing frequency with increasing temperature. (8) For operations above 200kHz up to 500kHz, see Discussion of Specifications and Installation and Operation sections. (9) One pulse of new frequency plus 1 μs .

ABSOLUTE MAXIMUM RATINGS

Supply Voltage	±22V
Output Sink Current (F_{OUT})	50mA
Output Current (V_{OUT})	+20mA
Input Voltage, -Input	±Supply
Input Voltage, +Input	±Supply
Comparator Input	±Supply
Storage Temperature Range:	
VFC32BM, SM	-65°C to +150°C
VFC32KP, KU	-25°C to +85°C

PACKAGE/ORDERING INFORMATION

PRODUCT	PACKAGE	PACKAGE DRAWING NUMBER ⁽¹⁾	TEMPERATURE RANGE
VFC32KP	14-Pin Plastic DIP	010	0°C to 70°C
VFC32BM	TO-100 Metal	007	-25°C to +85°C
VFC32SM	TO-100 Metal	007	-55°C to +125°C
VFC32KU	SO-14 SOIC	235	0°C to +70°C

NOTE: (1) For detailed drawing and dimension table, please see end of data sheet, or Appendix C of Burr-Brown IC Data Book.

PIN CONFIGURATIONS

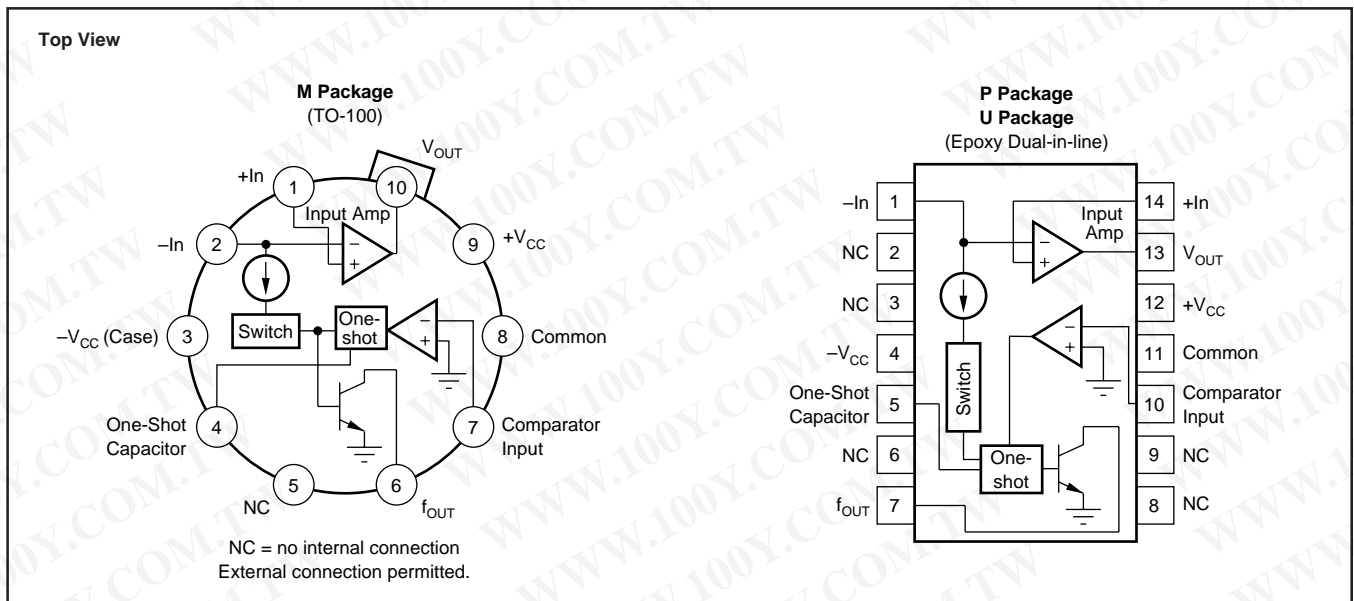

ELECTROSTATIC DISCHARGE SENSITIVITY

This integrated circuit can be damaged by ESD. Burr-Brown recommends that all integrated circuits be handled with appropriate precautions. Failure to observe proper handling and installation procedures can cause damage.

ESD damage can range from subtle performance degradation to complete device failure. Precision integrated circuits may be more susceptible to damage because very small parametric changes could cause the device not to meet its published specifications.

勝特力材料 886-3-5753170
 勝特力电子(上海) 86-21-54151736
 勝特力电子(深圳) 86-755-83298787
[Http://www.100y.com.tw](http://www.100y.com.tw)

The information provided herein is believed to be reliable; however, BURR-BROWN assumes no responsibility for inaccuracies or omissions. BURR-BROWN assumes no responsibility for the use of this information, and all use of such information shall be entirely at the user's own risk. Prices and specifications are subject to change without notice. No patent rights or licenses to any of the circuits described herein are implied or granted to any third party. BURR-BROWN does not authorize or warrant any BURR-BROWN product for use in life support devices and/or systems.

TYPICAL PERFORMANCE CURVES

At $T_A = +25^\circ\text{C}$ and $V_{CC} = \pm 15\text{V}$, unless otherwise noted.

勝特力材料 886-3-5753170
 勝特力电子(上海) 86-21-54151736
 勝特力电子(深圳) 86-755-83298787
[Http://www.100y.com.tw](http://www.100y.com.tw)

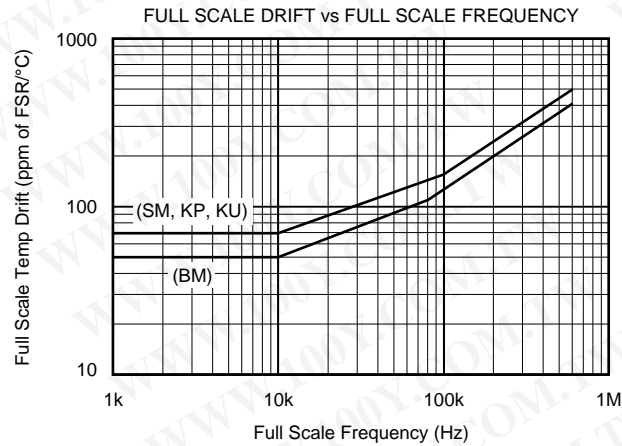
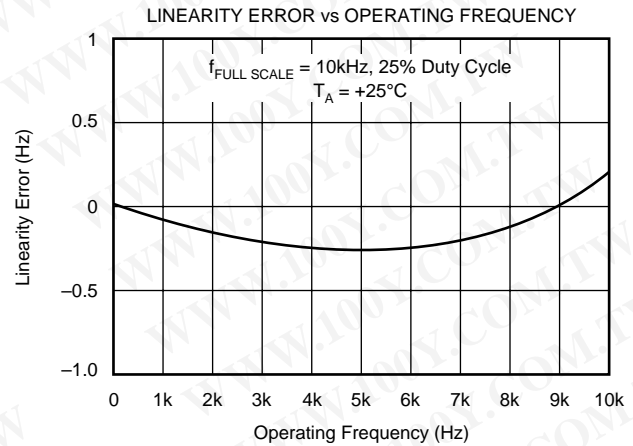
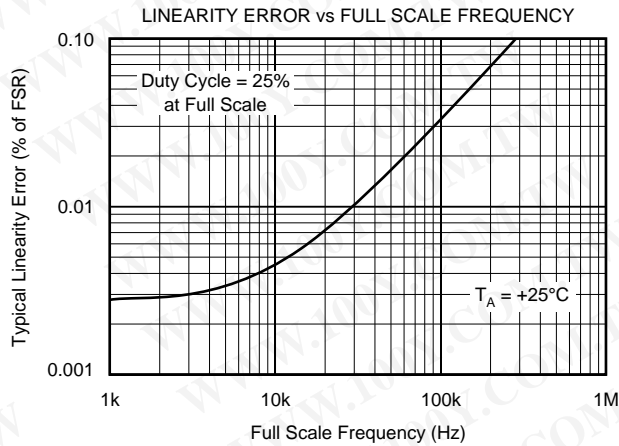

APPLICATION INFORMATION

Figure 1 shows the basic connection diagram for frequency-to-voltage conversion. R_1 sets the input voltage range. For a 10V full-scale input, a 40k Ω input resistor is recommended. Other input voltage ranges can be achieved by changing the value of R_1 .

$$R_1 = \frac{V_{FS}}{0.25\text{mA}} \quad (1)$$

R_1 should be a metal film type for good stability. Manufacturing tolerances can produce approximately $\pm 10\%$ variation in output frequency. Full-scale output frequency can be trimmed by adjusting the value of R_1 —see Figure 3.

The full-scale output frequency is determined by C_1 . Values shown in Figure 1 are for a full-scale output frequency of 10kHz. Values for other full-scale frequencies can be read from Figure 2. Any variation in C_1 —tolerance, temperature drift, aging—directly affect the output frequency. Ceramic NPO or silver-mica types are a good choice.

For full-scale frequencies above 200kHz, use larger capacitor values as indicated in Figure 2, with $R_1 = 20\text{k}\Omega$.

The value of the integrating capacitor, C_2 , does not directly influence the output frequency, but its value must be chosen within certain bounds. Values chosen from Figure 2 produce

approximately 2.5Vp-p integrator voltage waveform. If C_2 's value is made too low, the integrator output voltage can exceed its linear output swing, resulting in a nonlinear response. Using C_2 values larger than shown in Figure 2 is acceptable.

Accuracy or temperature stability of C_2 is not critical because its value does not directly affect the output frequency. For best linearity, however, C_2 should have low leakage and low dielectric absorption. Polycarbonate and other film capacitors are generally excellent. Many ceramic types are adequate, but some low-voltage ceramic capacitor types may degrade nonlinearity. Electrolytic types are not recommended.

FREQUENCY OUTPUT PIN

The frequency output terminal is an open-collector logic output. A pull-up resistor is usually connected to a 5V logic supply to create standard logic-level pulses. It can, however, be connected to any power supply up to $+V_{CC}$. Output pulses have a constant duration and positive-going during the one-shot period. Current flowing in the open-collector output transistor returns through the Common terminal. This terminal should be connected to logic ground.

勝特力材料 886-3-5753170
 勝特力电子(上海) 86-21-54151736
 勝特力电子(深圳) 86-755-83298787
[Http://www.100y.com.tw](http://www.100y.com.tw)

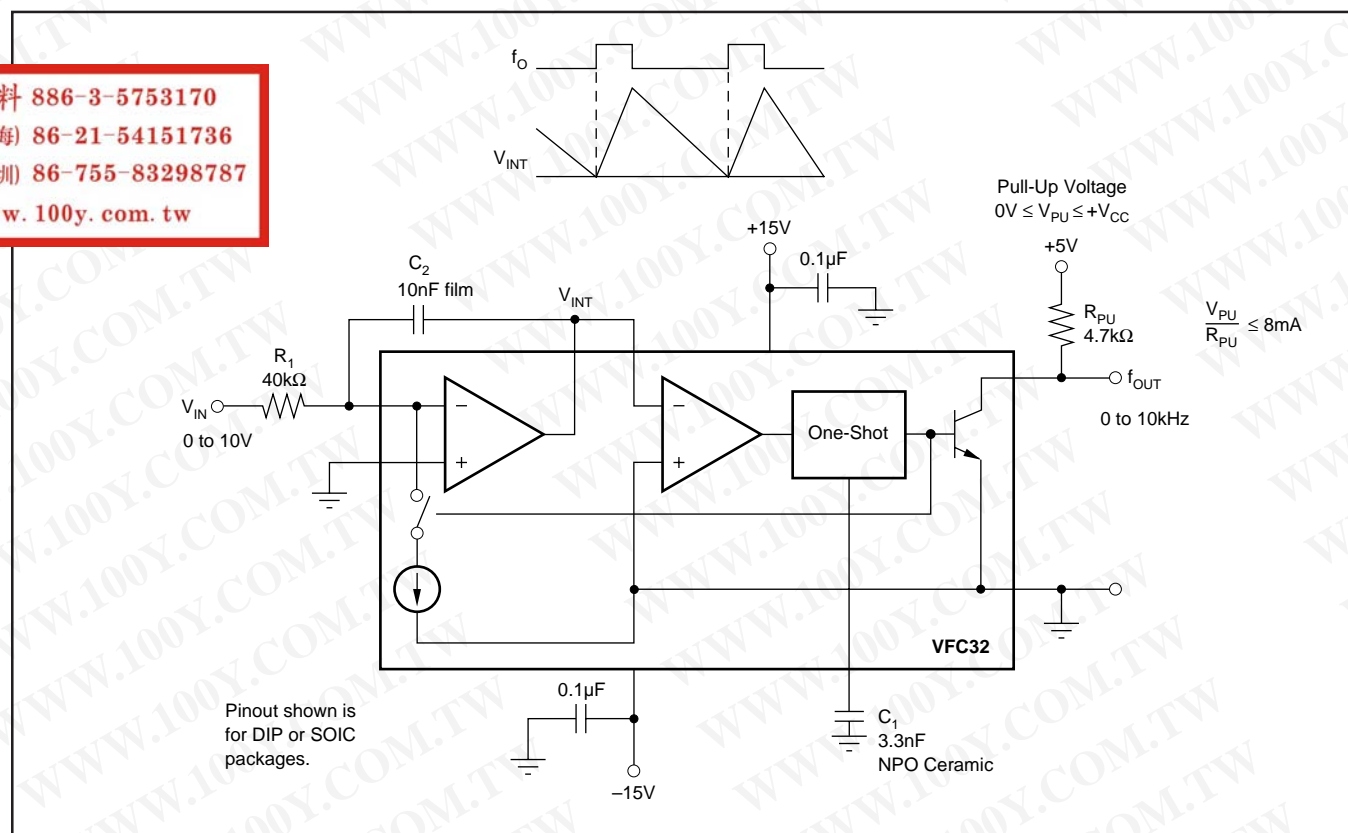

FIGURE 1. Voltage-to-Frequency Converter Circuit.

FREQUENCY-TO-VOLTAGE CONVERSION

Figure 4 shows the VFC32 connected as a frequency-to-voltage converter. The capacitive-coupled input network C_3 , R_6 and R_7 allow standard 5V logic levels to trigger the comparator input. The comparator triggers the one-shot on the falling edge of the frequency input pulses. Threshold voltage of the comparator is approximately $-0.7V$. For frequency input waveforms less than 5V logic levels, the R_6/R_7 voltage divider can be adjusted to a lower voltage to assure that the comparator is triggered.

The value of C_1 is chosen from Figure 2 according to the full-scale input frequency. C_2 smooths the output voltage waveform. Larger values of C_2 reduce the ripple in the output voltage. Smaller values of C_2 allow the output voltage to settle faster in response to a change in input frequency. Resistor R_1 can be trimmed to achieve the desired output voltage at the full-scale input frequency.

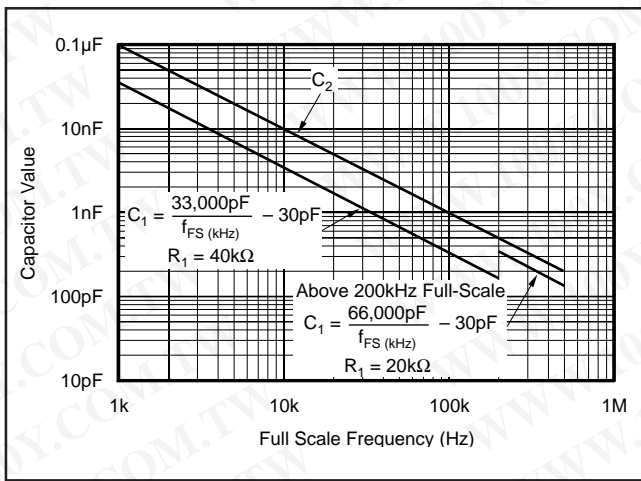

FIGURE 2. Capacitor Value Selection.

PRINCIPLES OF OPERATION

The VFC32 operates on a principle of charge balance. The signal input current is equal to V_{IN}/R_1 . This current is integrated by input op amp and C_2 , producing a downward ramping integrator output voltage. When the integrator output ramps to the threshold of the comparator, the one-shot is triggered. The 1mA reference current is switched to the integrator input during the one-shot period, causing the integrator output ramp upward. After the one-shot period, the integrator again ramps downward.

The oscillation process forces a long-term balance of charge (or average current) between the input signal current and the reference current. The equation for charge balance is:

$$I_{IN} = I_{R(AVERAGE)} \quad (2)$$

$$\frac{V_{IN}}{R_1} = f_O t_{OS} (1mA) \quad (3)$$

Where:

f_O is the output frequency

t_{OS} is the one-shot period, equal to

$$t_{OS} = 7500 C_1 (\text{Farads}) \quad (4)$$

The values suggested for R_1 and C_1 are chosen to produce a 25% duty cycle at full-scale frequency output. For full-scale frequencies above 200kHz, the recommended values produce a 50% duty cycle.

勝特力材料 886-3-5753170
 勝特力电子(上海) 86-21-54151736
 勝特力电子(深圳) 86-755-83298787
[Http://www.100y.com.tw](http://www.100y.com.tw)

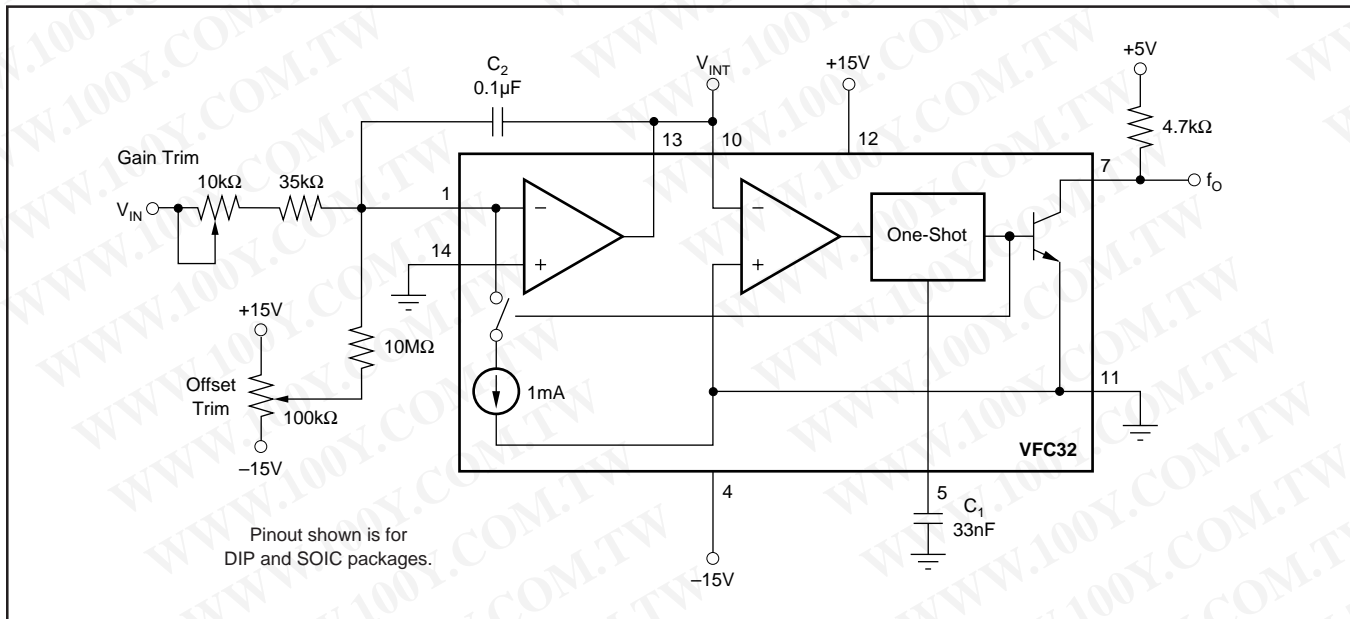

FIGURE 3. Gain and Offset Voltage Trim Circuit.

勝特力材料 886-3-5753170
 勝特力电子(上海) 86-21-54151736
 勝特力电子(深圳) 86-755-83298787
[Http://www.100y.com.tw](http://www.100y.com.tw)

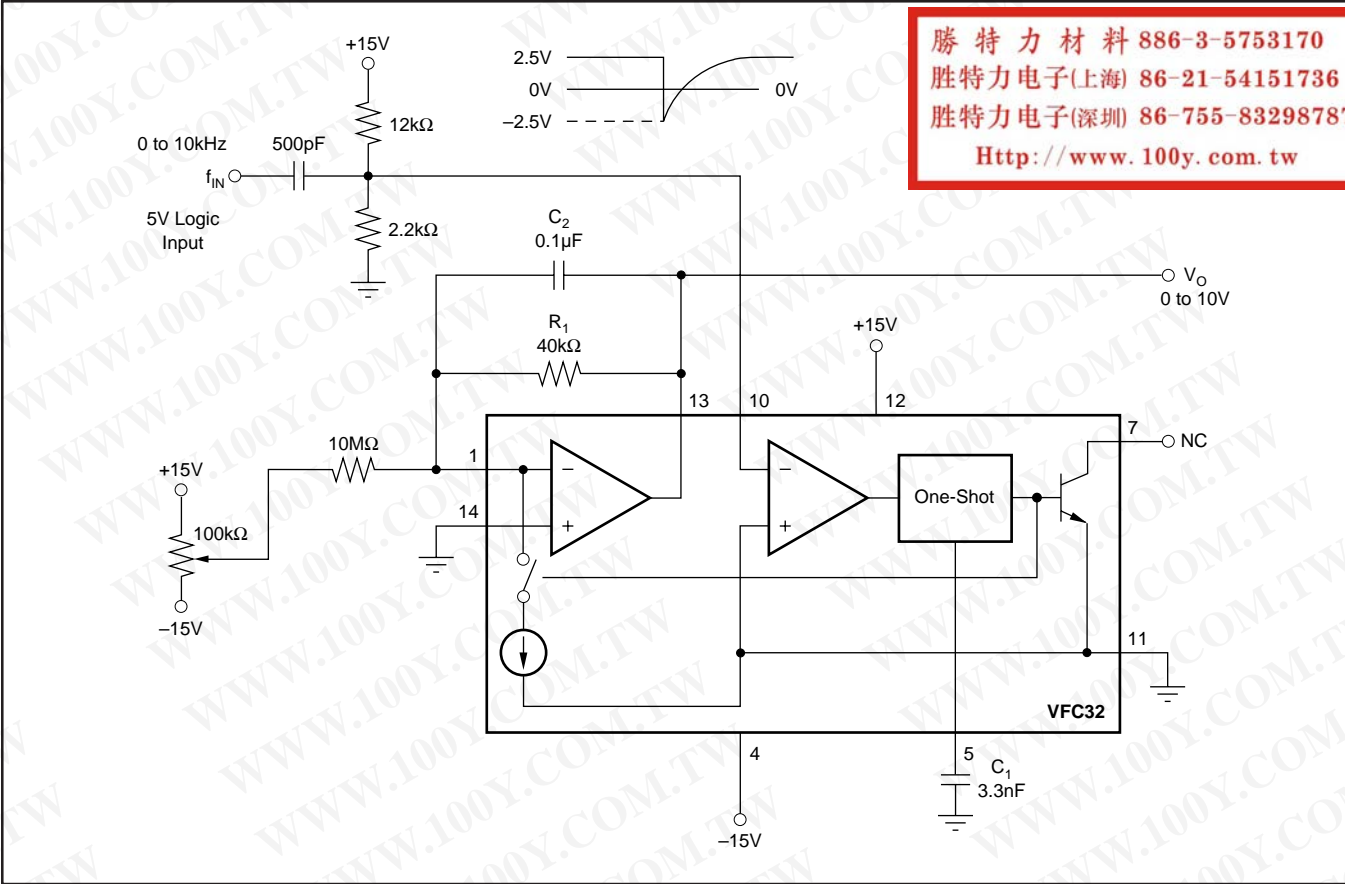

FIGURE 4. Frequency-to-Voltage Converter Circuit.

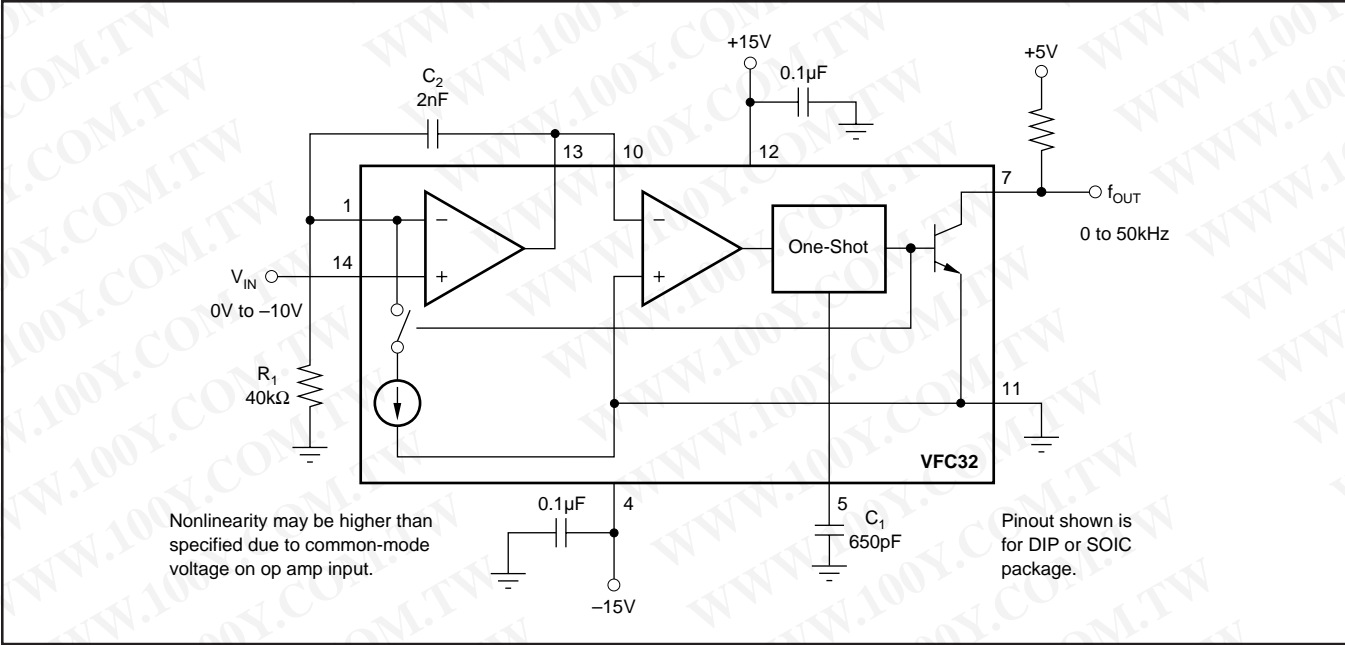

FIGURE 5. V/F Converter—Negative Input Voltage.

PACKAGING INFORMATION

Orderable Device	Status ⁽¹⁾	Package Type	Package Drawing	Pins	Package Qty	Eco Plan ⁽²⁾	Lead/Ball Finish	MSL Peak Temp ⁽³⁾
VFC32BM	OBSOLETE	TO-100	LME	10		TBD	Call TI	Call TI
VFC32KP	ACTIVE	PDIP	N	14	25	Green (RoHS & no Sb/Br)	CU NIPDAU	N / A for Pkg Type
VFC32KPG4	ACTIVE	PDIP	N	14	25	Green (RoHS & no Sb/Br)	CU NIPDAU	N / A for Pkg Type
VFC32KU	ACTIVE	SOIC	D	14	58	Green (RoHS & no Sb/Br)	CU NIPDAU	Level-3-260C-168 HR
VFC32KU/2K5	ACTIVE	SOIC	D	14	2500	Green (RoHS & no Sb/Br)	CU NIPDAU	Level-3-260C-168 HR
VFC32KU/2K5G4	ACTIVE	SOIC	D	14	2500	Green (RoHS & no Sb/Br)	CU NIPDAU	Level-3-260C-168 HR
VFC32KUE4	ACTIVE	SOIC	D	14	58	Green (RoHS & no Sb/Br)	CU NIPDAU	Level-3-260C-168 HR

⁽¹⁾ The marketing status values are defined as follows:

ACTIVE: Product device recommended for new designs.

LIFEBUY: TI has announced that the device will be discontinued, and a lifetime-buy period is in effect.

NRND: Not recommended for new designs. Device is in production to support existing customers, but TI does not recommend using this part in a new design.

PREVIEW: Device has been announced but is not in production. Samples may or may not be available.

OBSOLETE: TI has discontinued the production of the device.

⁽²⁾ Eco Plan - The planned eco-friendly classification: Pb-Free (RoHS), Pb-Free (RoHS Exempt), or Green (RoHS & no Sb/Br) - please check <http://www.ti.com/productcontent> for the latest availability information and additional product content details.

TBD: The Pb-Free/Green conversion plan has not been defined.

Pb-Free (RoHS): TI's terms "Lead-Free" or "Pb-Free" mean semiconductor products that are compatible with the current RoHS requirements for all 6 substances, including the requirement that lead not exceed 0.1% by weight in homogeneous materials. Where designed to be soldered at high temperatures, TI Pb-Free products are suitable for use in specified lead-free processes.

Pb-Free (RoHS Exempt): This component has a RoHS exemption for either 1) lead-based flip-chip solder bumps used between the die and package, or 2) lead-based die adhesive used between the die and leadframe. The component is otherwise considered Pb-Free (RoHS compatible) as defined above.

Green (RoHS & no Sb/Br): TI defines "Green" to mean Pb-Free (RoHS compatible), and free of Bromine (Br) and Antimony (Sb) based flame retardants (Br or Sb do not exceed 0.1% by weight in homogeneous material)

⁽³⁾ MSL, Peak Temp. -- The Moisture Sensitivity Level rating according to the JEDEC industry standard classifications, and peak solder temperature.

Important Information and Disclaimer:The information provided on this page represents TI's knowledge and belief as of the date that it is provided. TI bases its knowledge and belief on information provided by third parties, and makes no representation or warranty as to the accuracy of such information. Efforts are underway to better integrate information from third parties. TI has taken and continues to take reasonable steps to provide representative and accurate information but may not have conducted destructive testing or chemical analysis on incoming materials and chemicals. TI and TI suppliers consider certain information to be proprietary, and thus CAS numbers and other limited information may not be available for release.

In no event shall TI's liability arising out of such information exceed the total purchase price of the TI part(s) at issue in this document sold by TI to Customer on an annual basis.

勝特力材料 886-3-5753170
 勝特力电子(上海) 86-21-54151736
 勝特力电子(深圳) 86-755-83298787
[Http://www.100y.com.tw](http://www.100y.com.tw)

TAPE AND REEL INFORMATION

REEL DIMENSIONS

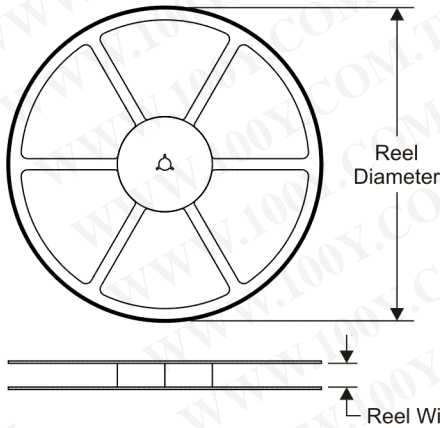

TAPE DIMENSIONS

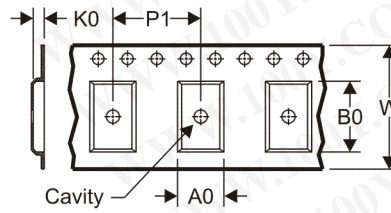

A0	Dimension designed to accommodate the component width
B0	Dimension designed to accommodate the component length
K0	Dimension designed to accommodate the component thickness
W	Overall width of the carrier tape
P1	Pitch between successive cavity centers

QUADRANT ASSIGNMENTS FOR PIN 1 ORIENTATION IN TAPE

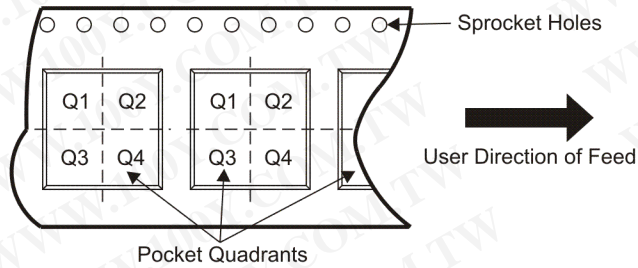

*All dimensions are nominal

Device	Package Type	Package Drawing	Pins	SPQ	Reel Diameter (mm)	Reel Width W1 (mm)	A0 (mm)	B0 (mm)	K0 (mm)	P1 (mm)	W (mm)	Pin1 Quadrant
VFC32KU/2K5	SOIC	D	14	2500	177.8	16.4	6.5	9.0	2.3	8.0	16.0	Q1

TAPE AND REEL BOX DIMENSIONS

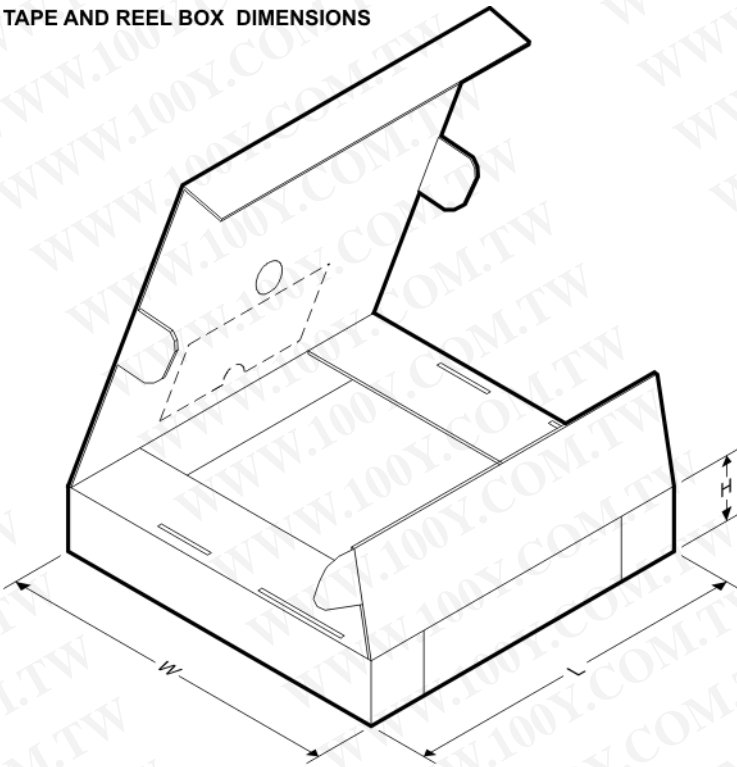

勝特力材料 886-3-5753170
 胜特力电子(上海) 86-21-54151736
 胜特力电子(深圳) 86-755-83298787
[Http://www.100y.com.tw](http://www.100y.com.tw)

*All dimensions are nominal

Device	Package Type	Package Drawing	Pins	SPQ	Length (mm)	Width (mm)	Height (mm)
VFC32KU/2K5	SOIC	D	14	2500	375.0	340.0	57.0

勝特力材料 886-3-5753170
勝特力电子(上海) 86-21-54151736
勝特力电子(深圳) 86-755-83298787
[Http://www.100y.com.tw](http://www.100y.com.tw)

IMPORTANT NOTICE

Texas Instruments Incorporated and its subsidiaries (TI) reserve the right to make corrections, modifications, enhancements, improvements, and other changes to its products and services at any time and to discontinue any product or service without notice. Customers should obtain the latest relevant information before placing orders and should verify that such information is current and complete. All products are sold subject to TI's terms and conditions of sale supplied at the time of order acknowledgment.

TI warrants performance of its hardware products to the specifications applicable at the time of sale in accordance with TI's standard warranty. Testing and other quality control techniques are used to the extent TI deems necessary to support this warranty. Except where mandated by government requirements, testing of all parameters of each product is not necessarily performed.

TI assumes no liability for applications assistance or customer product design. Customers are responsible for their products and applications using TI components. To minimize the risks associated with customer products and applications, customers should provide adequate design and operating safeguards.

TI does not warrant or represent that any license, either express or implied, is granted under any TI patent right, copyright, mask work right, or other TI intellectual property right relating to any combination, machine, or process in which TI products or services are used. Information published by TI regarding third-party products or services does not constitute a license from TI to use such products or services or a warranty or endorsement thereof. Use of such information may require a license from a third party under the patents or other intellectual property of the third party, or a license from TI under the patents or other intellectual property of TI.

Reproduction of TI information in TI data books or data sheets is permissible only if reproduction is without alteration and is accompanied by all associated warranties, conditions, limitations, and notices. Reproduction of this information with alteration is an unfair and deceptive business practice. TI is not responsible or liable for such altered documentation. Information of third parties may be subject to additional restrictions.

Resale of TI products or services with statements different from or beyond the parameters stated by TI for that product or service voids all express and any implied warranties for the associated TI product or service and is an unfair and deceptive business practice. TI is not responsible or liable for any such statements.

TI products are not authorized for use in safety-critical applications (such as life support) where a failure of the TI product would reasonably be expected to cause severe personal injury or death, unless officers of the parties have executed an agreement specifically governing such use. Buyers represent that they have all necessary expertise in the safety and regulatory ramifications of their applications, and acknowledge and agree that they are solely responsible for all legal, regulatory and safety-related requirements concerning their products and any use of TI products in such safety-critical applications, notwithstanding any applications-related information or support that may be provided by TI. Further, Buyers must fully indemnify TI and its representatives against any damages arising out of the use of TI products in such safety-critical applications.

TI products are neither designed nor intended for use in military/aerospace applications or environments unless the TI products are specifically designated by TI as military-grade or "enhanced plastic." Only products designated by TI as military-grade meet military specifications. Buyers acknowledge and agree that any such use of TI products which TI has not designated as military-grade is solely at the Buyer's risk, and that they are solely responsible for compliance with all legal and regulatory requirements in connection with such use.

TI products are neither designed nor intended for use in automotive applications or environments unless the specific TI products are designated by TI as compliant with ISO/TS 16949 requirements. Buyers acknowledge and agree that, if they use any non-designated products in automotive applications, TI will not be responsible for any failure to meet such requirements.

Following are URLs where you can obtain information on other Texas Instruments products and application solutions:

Products

Amplifiers	amplifier.ti.com
Data Converters	dataconverter.ti.com
DSP	dsp.ti.com
Clocks and Timers	www.ti.com/clocks
Interface	interface.ti.com
Logic	logic.ti.com
Power Mgmt	power.ti.com
Microcontrollers	microcontroller.ti.com
RFID	www.ti-rfid.com
RF/IF and ZigBee® Solutions	www.ti.com/lprf

Applications

Audio	www.ti.com/audio
Automotive	www.ti.com/automotive
Broadband	www.ti.com/broadband
Digital Control	www.ti.com/digitalcontrol
Medical	www.ti.com/medical
Military	www.ti.com/military
Optical Networking	www.ti.com/opticalnetwork
Security	www.ti.com/security
Telephony	www.ti.com/telephony
Video & Imaging	www.ti.com/video
Wireless	www.ti.com/wireless

Mailing Address: Texas Instruments, Post Office Box 655303, Dallas, Texas 75265
Copyright © 2008, Texas Instruments Incorporated