

November 1997 - Revised May 2000

**Features**

- **Wide Analog Input Voltage Range** . . . . .  $\pm 5V$  Max
- **Low "On" Resistance**
  - 70 $\Omega$  Typical ( $V_{CC} - V_{EE} = 4.5V$ )
  - 40 $\Omega$  Typical ( $V_{CC} - V_{EE} = 9V$ )
- **Low Crosstalk between Switches**
- **Fast Switching and Propagation Speeds**
- **"Break-Before-Make" Switching**
- **Wide Operating Temperature Range** . . -55 $^{\circ}C$  to 125 $^{\circ}C$
- **CD54HC/CD74HC Types**
  - **Operation Control Voltage** . . . . . 2V to 6V
  - **Switch Voltage** . . . . . 0V to 10V
  - **High Noise Immunity** . . .  $N_{IL} = 30\%$ ,  $N_{IH} = 30\%$  of  $V_{CC}$ ,  $V_{CC} = 5V$
- **CD54HCT/CD74HCT Types**
  - **Operation Control Voltage** . . . . . 4.5V to 5.5V
  - **Switch Voltage** . . . . . 0V to 10V
  - **Direct LSTTL Input Logic Compatibility** . . .  $V_{IL} = 0.8V$  Max,  $V_{IH} = 2V$  Min
  - **CMOS Input Compatibility** . . . . .  $I_I \leq 1\mu A$  at  $V_{OL}$ ,  $V_{OH}$

**Description**

These devices are digitally controlled analog switches which utilize silicon gate CMOS technology to achieve operating speeds similar to LSTTL with the low power consumption of standard CMOS integrated circuits.

These analog multiplexers/demultiplexers control analog voltages that may vary across the voltage supply range (i.e.  $V_{CC}$  to  $V_{EE}$ ). They are bidirectional switches thus allowing any analog input to be used as an output and visa-versa. The switches have low "on" resistance and low "off" leakages. In addition, all three devices have an enable control which, when high, disables all switches to their "off" state.

**Ordering Information**

PART NUMBER	TEMP. RANGE (°C)	PACKAGE
CD54HC4051F	-55 to 125	16 Ld CERDIP
CD54HC4051F3A	-55 to 125	16 Ld CERDIP
CD74HC4051E	-55 to 125	16 Ld PDIP
CD74HC4051M	-55 to 125	16 Ld SOIC
CD54HCT4051F3A	-55 to 125	16 Ld CERDIP
CD74HCT4051E	-55 to 125	16 Ld PDIP
CD74HCT4051M	-55 to 125	16 Ld SOIC
CD54HC4052F	-55 to 125	16 Ld CERDIP
CD54HC4052F3A	-55 to 125	16 Ld CERDIP
CD74HC4052E	-55 to 125	16 Ld PDIP
CD74HC4052M	-55 to 125	16 Ld SOIC
CD74HCT4052E	-55 to 125	16 Ld PDIP
CD74HCT4052M	-55 to 125	16 Ld SOIC
CD74HCT4052SM	-55 to 125	16 Ld SSOP
CD54HC4053F	-55 to 125	16 Ld CERDIP
CD54HC4053F3A	-55 to 125	16 Ld CERDIP
CD74HC4053E	-55 to 125	16 Ld PDIP
CD74HC4053M	-55 to 125	16 Ld SOIC
CD74HCT4053E	-55 to 125	16 Ld PDIP
CD74HCT4053M	-55 to 125	16 Ld SOIC
CD74HCT4053PW	-55 to 125	16 Ld TSSOP

**NOTES:**

1. When ordering, use the entire part number. Add the suffix 96 to obtain the variant in the tape and reel. For the TSSOP package only, add the suffix R to obtain the variant in the tape and reel.
2. Wafer or die is available which meets all electrical specifications. Please contact your local TI sales office or customer service for ordering information.

勝特力材料 886-3-5753170  
 勝特力电子(上海) 86-21-54151736  
 勝特力电子(深圳) 86-755-83298787  
[Http://www.100y.com.tw](http://www.100y.com.tw)

'HC4051, 'HCT4051, 'HC4052, CD74HCT4052, 'HC4053, CD74HCT4053

Pinouts

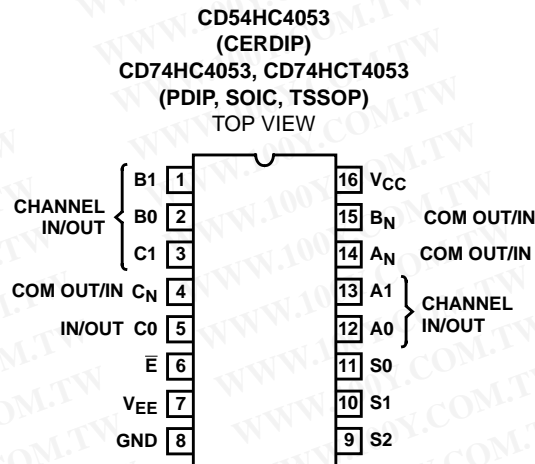
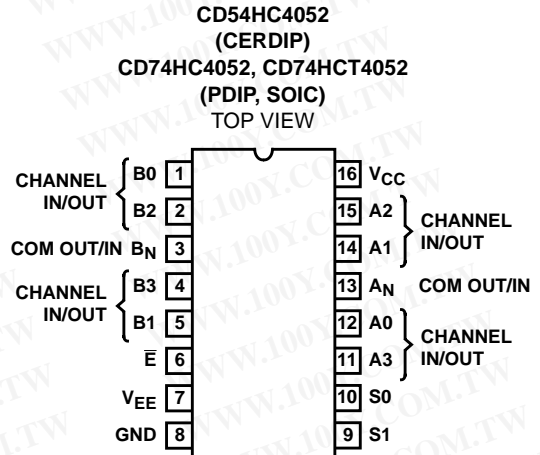
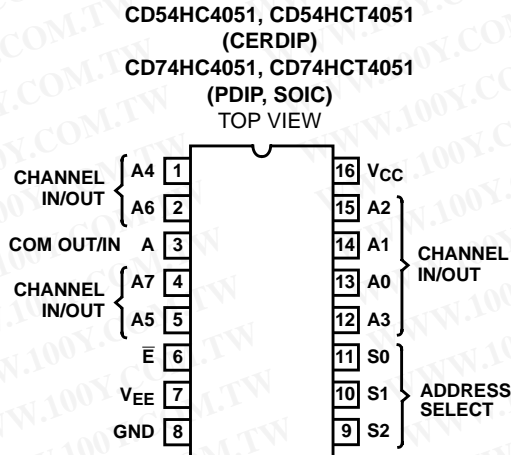

勝特力材料 886-3-5753170  
 勝特力电子(上海) 86-21-54151736  
 勝特力电子(深圳) 86-755-83298787  
[Http://www.100y.com.tw](http://www.100y.com.tw)

Functional Diagram of HC/HCT4051

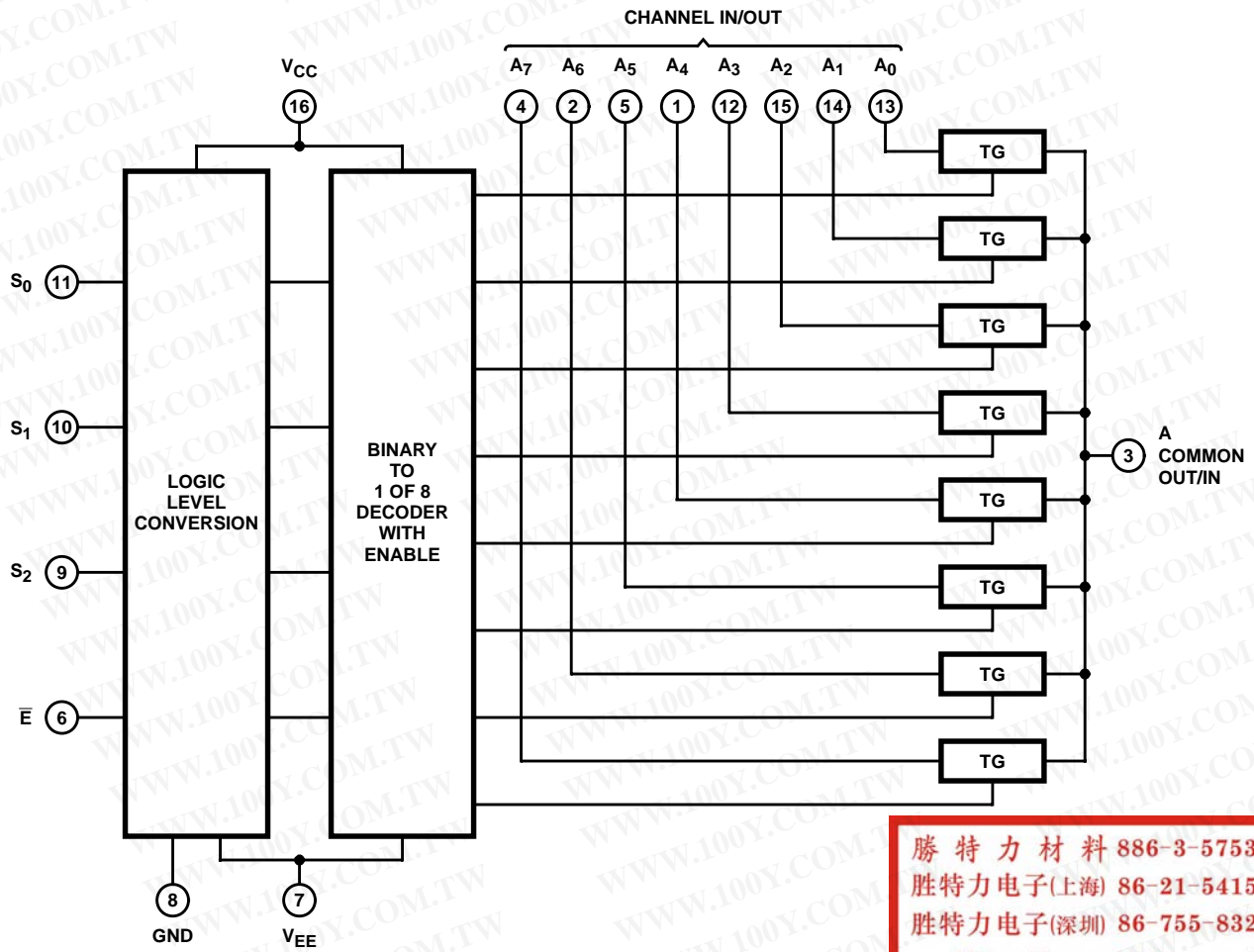

勝特力材料 886-3-5753170  
 勝特力电子(上海) 86-21-54151736  
 勝特力电子(深圳) 86-755-83298787  
[Http://www.100y.com.tw](http://www.100y.com.tw)

TRUTH TABLE  
 HC/HCT4051

INPUT STATES				"ON" CHANNELS
ENABLE	S <sub>2</sub>	S <sub>1</sub>	S <sub>0</sub>	
L	L	L	L	A0
L	L	L	H	A1
L	L	H	L	A2
L	L	H	H	A3
L	H	L	L	A4
L	H	L	H	A5
L	H	H	L	A6
L	H	H	H	A7
H	X	X	X	None

X = Don't care

'HC4051, 'HCT4051, 'HC4052, CD74HCT4052, 'HC4053, CD74HCT4053

Functional Diagram of 'HC4052, CD74HCT4052

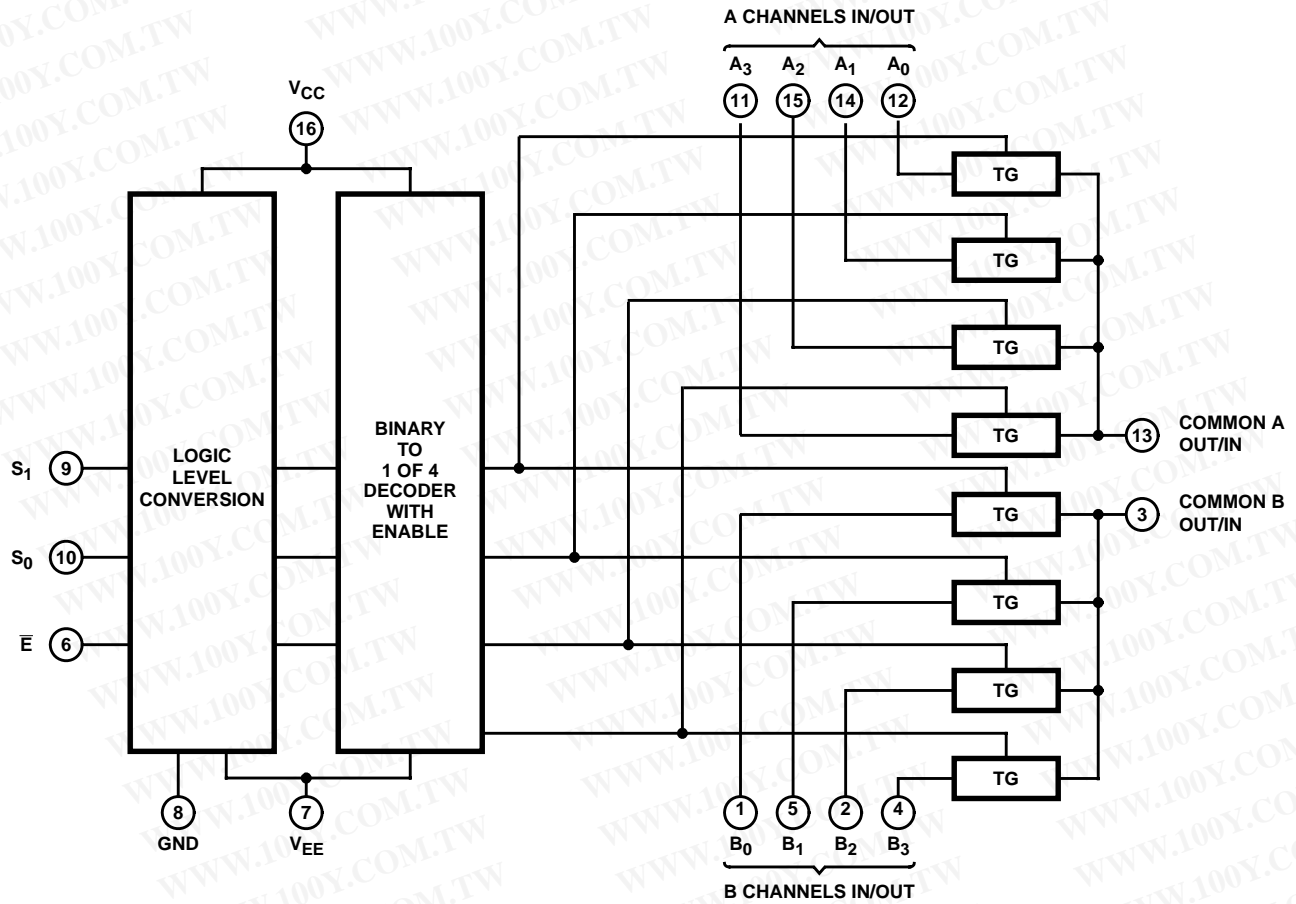

TRUTH TABLE  
'HC4052, CD74HCT4052

INPUT STATES			"ON" CHANNELS
ENABLE	S <sub>1</sub>	S <sub>0</sub>	
L	L	L	A0, B0
L	L	H	A1, B1
L	H	L	A2, B2
L	H	H	A3, B3
H	X	X	None

X = Don't care

勝特力材料 886-3-5753170  
 勝特力电子(上海) 86-21-54151736  
 勝特力电子(深圳) 86-755-83298787  
[Http://www.100y.com.tw](http://www.100y.com.tw)

**Functional Diagram of 'HC4053, CD74HCT4053**

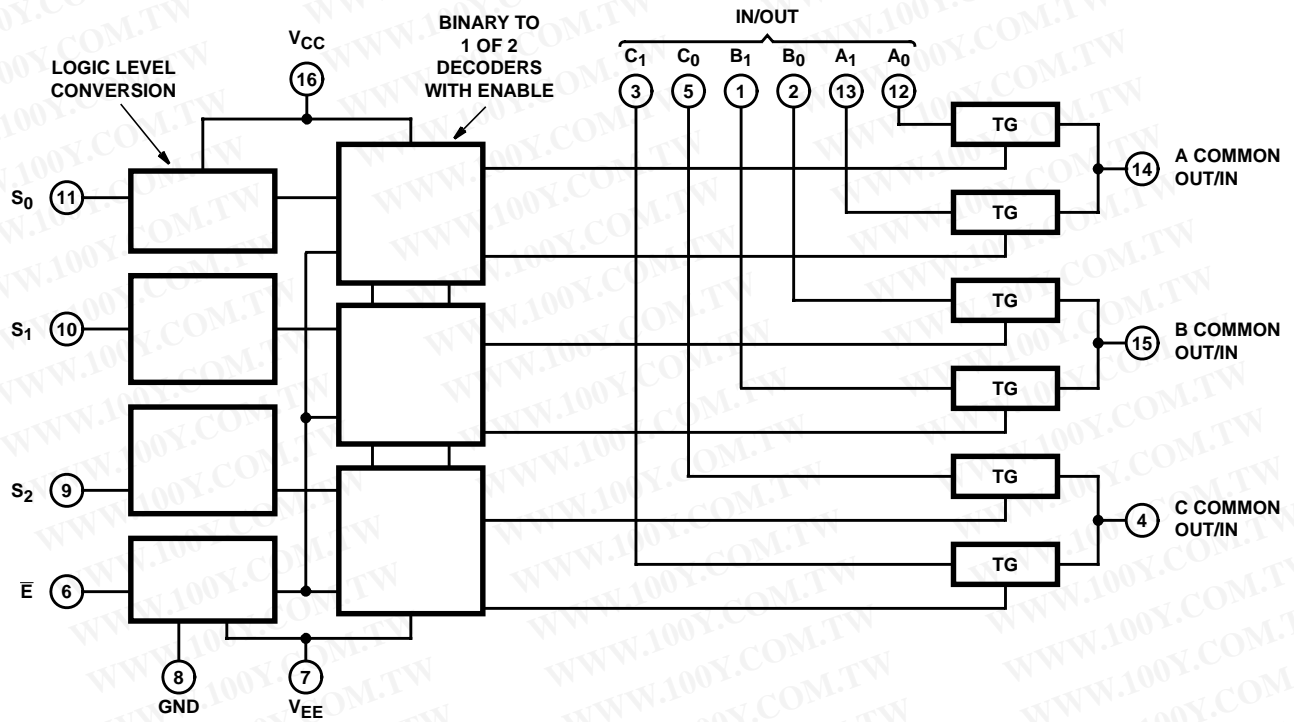

**TRUTH TABLE**  
**'HC4053, CD74HCT4053**

INPUT STATES				"ON" CHANNELS
ENABLE	S <sub>0</sub>	S <sub>1</sub>	S <sub>2</sub>	
L	L	L	L	C0, B0, A0
L	H	L	L	C0, B0, A1
L	L	H	L	C0, B1, A0
L	H	H	L	C0, B1, A1
L	L	L	H	C1, B0, A0
L	H	L	H	C1, B0, A1
L	L	H	H	C1, B1, A0
L	H	H	H	C1, B1, A1
H	X	X	X	None

X = Don't care

勝特力材料 886-3-5753170  
 勝特力电子(上海) 86-21-54151736  
 勝特力电子(深圳) 86-755-83298787  
[Http://www.100y.com.tw](http://www.100y.com.tw)

# 'HC4051, 'HCT4051, 'HC4052, CD74HCT4052, 'HC4053, CD74HCT4053

## Absolute Maximum Ratings (Note 3)

DC Supply Voltage, $V_{CC} - V_{EE}$ .....	-0.5V to 10.5V
DC Supply Voltage, $V_{CC}$ .....	-0.5V to +7V
DC Supply Voltage, $V_{EE}$ .....	+0.5V to -7V
DC Input Diode Current, $I_{IK}$ For $V_I < -0.5V$ or $V_I > V_{CC} + 0.5V$ .....	$\pm 20mA$
DC Switch Diode Current, $I_{OK}$ For $V_I < V_{EE} - 0.5V$ or $V_I > V_{CC} + 0.5V$ .....	$\pm 20mA$
DC Switch Current, (Note 2) For $V_I > V_{EE} - 0.5V$ or $V_I < V_{CC} + 0.5V$ .....	$\pm 25mA$
DC $V_{CC}$ or Ground Current, $I_{CC}$ .....	$\pm 50mA$
DC $V_{EE}$ Current, $I_{EE}$ .....	-20mA

## Thermal Information

Thermal Resistance (Typical, Note 4)	$\theta_{JA}$ ( $^{\circ}C/W$ )	$\theta_{JC}$ ( $^{\circ}C/W$ )
PDIP Package .....	90	N/A
SOIC Package .....	160	N/A
CERDIP Package .....	130	55
TSSOP Package .....	149	35
Maximum Junction Temperature .....	150 $^{\circ}C$	
Maximum Storage Temperature Range .....	-65 $^{\circ}C$ to 150 $^{\circ}C$	
Maximum Lead Temperature (Soldering 10s) .....	300 $^{\circ}C$	

## Recommended Operating Conditions

For maximum reliability, nominal operating conditions should be selected so that operation is always within the following ranges

PARAMETER	MIN	MAX	UNITS
Supply Voltage Range (For $T_A$ = Full Package Temperature Range), $V_{CC}$ (Note 5) CD54/74HC Types	2	6	V
CD54/74HCT Types	4.5	5.5	V
Supply Voltage Range (For $T_A$ = Full Package Temperature Range), $V_{CC} - V_{EE}$ CD54/74HC Types, CD54/74HCT Types (See Figure 1)	2	10	V
Supply Voltage Range (For $T_A$ = Full Package Temperature Range), $V_{EE}$ (Note 5) CD54/74HC Types, CD54/74HCT Types (See Figure 2)	0	-6	V
DC Input Control Voltage, $V_I$	GND	$V_{CC}$	V
Analog Switch I/O Voltage, $V_{IS}$	$V_{EE}$	$V_{CC}$	V
Operating Temperature, $T_A$	-55	125	$^{\circ}C$
Input Rise and Fall Times, $t_r, t_f$			
2V	0	1000	ns
4.5V	0	500	ns
6V	0	400	ns

CAUTION: Stresses above those listed in "Absolute Maximum Ratings" may cause permanent damage to the device. This is a stress only rating and operation of the device at these or any other conditions above those indicated in the operational sections of this specification is not implied.

### NOTES:

- All voltages referenced to GND unless otherwise specified.
- $\theta_{JA}$  is measured with the component mounted on an evaluation PC board in free air.
- In certain applications, the external load resistor current may include both  $V_{CC}$  and signal line components. To avoid drawing  $V_{CC}$  current when switch current flows into the transmission gate inputs, the voltage drop across the bidirectional switch must not exceed 0.6V (calculated from  $r_{ON}$  values shown in Electrical Specifications table). No  $V_{CC}$  current will flow through  $R_L$  if the switch current flows into terminal 3 on the HC/HCT4051; terminals 3 and 13 on the HC/HCT4052; terminals 4, 14 and 15 on the HC/HCT4053.

## Recommended Operating Area as a Function of Supply Voltages

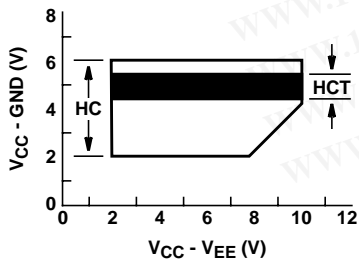

FIGURE 1.

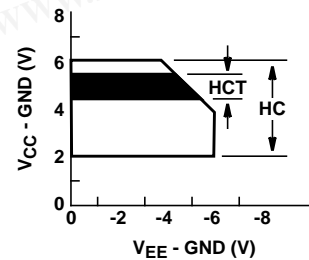

FIGURE 2.

勝特力材料 886-3-5753170  
 勝特力电子(上海) 86-21-54151736  
 勝特力电子(深圳) 86-755-83298787  
[Http://www.100y.com.tw](http://www.100y.com.tw)

**'HC4051, 'HCT4051, 'HC4052, CD74HCT4052, 'HC4053, CD74HCT4053**

**DC Electrical Specifications**

PARAMETER	TEST CONDITIONS				AMBIENT TEMPERATURE, T <sub>A</sub>						UNITS		
	V <sub>IS</sub> (V)	V <sub>I</sub> (V)	V <sub>EE</sub> (V)	V <sub>CC</sub> (V)	25°C			-40°C - 85°C		-55°C - 125°C			
					MIN	TYP	MAX	MIN	MAX	MIN		MAX	
<b>HC TYPES</b>													
High Level Input Voltage, V <sub>IH</sub>				2	1.5	-	-	1.5	-	1.5	-	V	
				4.5	3.15	-	-	3.15	-	3.15	0	V	
				6	4.2	-	-	4.2	-	4.2	-	V	
Low Level Input Voltage, V <sub>IL</sub>				2	-	-	0.5	-	0.5	-	0.5	V	
				4.5	-	-	1.35	-	1.35	-	1.35	V	
				6	-	-	1.8	-	1.8	-	1.8	V	
On Resistance, r <sub>ON</sub> I <sub>O</sub> = 1mA, (Figure 11)	V <sub>CC</sub> or V <sub>EE</sub>	V <sub>IL</sub> or V <sub>IH</sub>	0	4.5	-	70	160	-	200	-	240	Ω	
			0	6	-	60	140	-	175	-	210	Ω	
			-4.5	4.5	-	40	120	-	150	-	180	Ω	
	V <sub>CC</sub> to V <sub>EE</sub>		0	4.5	-	90	180	-	225	-	270	Ω	
			0	6	-	80	160	-	200	-	240	Ω	
			-4.5	4.5	-	45	130	-	162	-	195	Ω	
Maximum On Resistance Between any Two Channels, Δr <sub>ON</sub>			0	4.5	-	10	-	-	-	-	Ω		
			0	6	-	8.5	-	-	-	-	Ω		
			-4.5	4.5	-	5	-	-	-	-	Ω		
Switch On/Off Leakage Current, I <sub>IZ</sub>	For Switch Off: When V <sub>IS</sub> = V <sub>CC</sub> , V <sub>OS</sub> = V <sub>EE</sub> ; When V <sub>IS</sub> = V <sub>EE</sub> , V <sub>OS</sub> = V <sub>CC</sub> For Switch On: All Applicable Combinations of V <sub>IS</sub> and V <sub>OS</sub> Voltage Levels	V <sub>IL</sub> or V <sub>IH</sub>	1 and 2 Channels	0	6	-	-	±0.1	-	±1	-	±1	μA
			4053	-5	5	-	-	±0.1	-	±1	-	±1	μA
			4 Channels	0	6	-	-	±0.1	-	±1	-	±1	μA
			4052	-5	5	-	-	±0.2	-	±2	-	±2	μA
			8 Channels	0	6	-	-	±0.2	-	±2	-	±2	μA
			4051	-5	5	-	-	±0.4	-	±4	-	±4	μA
			Control Input Leakage Current, I <sub>IL</sub>		V <sub>CC</sub> or GND	0	6	-	-	±0.1	-	±1	-
Quiescent Device Current, I <sub>CC</sub> I <sub>O</sub> = 0	When V <sub>IS</sub> = V <sub>EE</sub> , V <sub>OS</sub> = V <sub>CC</sub>	V <sub>CC</sub> or GND	0	6	-	-	8	-	80	-	160	μA	
	When V <sub>IS</sub> = V <sub>CC</sub> , V <sub>OS</sub> = V <sub>EE</sub>		-5	5	-	-	16	-	160	-	320	μA	

**勝特力材料 886-3-5753170**  
**勝特力电子(上海) 86-21-54151736**  
**勝特力电子(深圳) 86-755-83298787**  
[Http://www.100y.com.tw](http://www.100y.com.tw)

**'HC4051, 'HCT4051, 'HC4052, CD74HCT4052, 'HC4053, CD74HCT4053**

**DC Electrical Specifications (Continued)**

PARAMETER	TEST CONDITIONS				AMBIENT TEMPERATURE, T <sub>A</sub>						UNITS		
	V <sub>IS</sub> (V)	V <sub>I</sub> (V)	V <sub>EE</sub> (V)	V <sub>CC</sub> (V)	25°C			-40°C - 85°C		-55°C - 125°C			
					MIN	TYP	MAX	MIN	MAX	MIN		MAX	
<b>HCT TYPES</b>													
High Level Input Voltage, V <sub>IH</sub>				4.5 to 5.5	2	-	-	2	-	2	-	V	
Low Level Input Voltage, V <sub>IL</sub>				4.5 to 5.5	-	-	0.8	-	0.8	-	0.8	V	
On Resistance, r <sub>ON</sub> I <sub>O</sub> = 1mA, (Figure 15)	V <sub>CC</sub> or V <sub>EE</sub>	V <sub>IL</sub> or V <sub>IH</sub>	0	4.5	-	70	160	-	200	-	240	Ω	
			-	-	-	-	-	-	-	-	-	Ω	
			-4.5	4.5	-	40	120	-	150	-	180	Ω	
	V <sub>CC</sub> to V <sub>EE</sub>		0	4.5	-	90	180	-	225	-	270	Ω	
			-	-	-	-	-	-	-	-	-	-	Ω
			-4.5	4.5	-	45	130	-	162	-	195	Ω	
Maximum On Resistance Between any Two Channels, Δr <sub>ON</sub>			0	4.5	-	10	-	-	-	-	-	Ω	
			-	-	-	-	-	-	-	-	-	Ω	
			-4.5	4.5	-	5	-	-	-	-	-	Ω	
Switch On/Off Leakage Current, I <sub>Iz</sub>	For Switch Off: When V <sub>IS</sub> = V <sub>CC</sub> , V <sub>OS</sub> = V <sub>EE</sub> ; When V <sub>IS</sub> = V <sub>EE</sub> , V <sub>OS</sub> = V <sub>CC</sub> For Switch On: All Applicable Combinations of V <sub>IS</sub> and V <sub>OS</sub> Voltage Levels	V <sub>IL</sub> or V <sub>IH</sub>											
1 and 2 Channels			0	6	-	-	±0.1	-	±1	-	±1	μA	
4053			-5	5	-	-	±0.1	-	±1	-	±1	μA	
4 Channels			0	6	-	-	±0.1	-	±1	-	±1	μA	
4052			-5	5	-	-	±0.2	-	±2	-	±2	μA	
8 Channels			0	6	-	-	±0.2	-	±2	-	±2	μA	
4051	-5	5	-	-	±0.4	-	±4	-	±4	μA			
Control Input Leakage Current, I <sub>IL</sub>	-	(Note 7)	-	5.5	-	-	±0.1	-	±1	-	±1	μA	
Quiescent Device Current, I <sub>CC</sub> I <sub>O</sub> = 0	When V <sub>IS</sub> = V <sub>EE</sub> , V <sub>OS</sub> = V <sub>CC</sub>	V <sub>CC</sub> or GND	0	5.5	-	-	8	-	80	-	160	μA	
	When V <sub>IS</sub> = V <sub>CC</sub> , V <sub>OS</sub> = V <sub>EE</sub>		-4.5	5.5	-	-	16	-	160	-	320	μA	
Additional Quiescent Device Current, ΔI <sub>CC</sub> (Note 6) Per Input Pin: 1 Unit Load		V <sub>CC</sub> - 2.1	4.5 to 5.5	-	100	360	-	450	-	490	μA		

**NOTES:**

- For dual supply systems theoretical worst case (V<sub>I</sub> = 2.4V, V<sub>CC</sub> = 5.5V) specification is 1.8mA.
- Any voltage between V<sub>CC</sub> and GND.

**HCT Input Loading Table**

TYPE	INPUT	UNIT LOADS (NOTE)
4051, 4053	All	0.5
4052	All	0.4

NOTE: Unit load is ΔI<sub>CC</sub> limit specified in DC Specifications table, e.g., 360mA max. at 25°C.

**勝特力材料 886-3-5753170**  
**勝特力电子(上海) 86-21-54151736**  
**勝特力电子(深圳) 86-755-83298787**  
[Http://www.100y.com.tw](http://www.100y.com.tw)



**'HC4051, 'HCT4051, 'HC4052, CD74HCT4052, 'HC4053, CD74HCT4053**

**Switching Specifications**  $V_{CC} = 5V, T_A = 25^{\circ}C, \text{Input } t_r, t_f = 6ns$

PARAMETER	$C_L$ (pF)	TYPICAL						UNITS
		4051		4052		4053		
		HC	HCT	HC	HCT	HC	HCT	
Propagation Delay Switch IN to OUT, $t_{PHL}, t_{PLH}$	15	4	4	4	4	4	4	ns
Switch Turn-Off (S or $\bar{E}$ ), $t_{PHZ}, t_{PLZ}$	15	19	19	21	21	18	18	ns
Switch Turn-On (S or $\bar{E}$ ), $t_{PZH}, t_{PZL}$	15	19	23	27	29	18	20	ns
Power Dissipation Capacitance, $C_{PD}$ (Note 8)	-	50	52	74	76	38	42	pF

NOTE:

8.  $C_{PD}$  is used to determine the dynamic power consumption, per package.

$$P_D = C_{PD} V_{CC}^2 f_I + \sum (C_L + C_S) V_{CC}^2 f_O$$

$f_O$  = output frequency

$f_I$  = input frequency

$C_L$  = output load capacitance

$C_S$  = switch capacitance

$V_{CC}$  = supply voltage

**勝特力材料 886-3-5753170**  
**勝特力电子(上海) 86-21-54151736**  
**勝特力电子(深圳) 86-755-83298787**  
[Http://www.100y.com.tw](http://www.100y.com.tw)

**Switching Specifications**  $C_L = 50pF, \text{Input } t_r, t_f = 6ns$

PARAMETER	$V_{EE}$ (V)	$V_{CC}$ (V)	AMBIENT TEMPERATURE, $T_A$												UNITS	
			25°C				-40°C - 85°C				-55°C - 125°C					
			HC		HCT		HC		HCT		HC		HCT			
			MIN	MAX	MIN	MAX	MIN	MAX	MIN	MAX	MIN	MAX	MIN	MAX		
Propagation Delay, Switch In to Out, $t_{PLH}, t_{PHL}$	0	2	-	60	-	-	-	75	-	-	-	90	-	-	ns	
	0	4.5	-	12	-	12	-	15	-	15	-	18	-	18	ns	
	0	6	-	10	-	-	-	13	-	-	-	15	-	-	ns	
	-4.5	4.5	-	8	-	8	-	10	-	10	-	12	-	12	ns	
Maximum Switch Turn "Off" Delay from S or $\bar{E}$ to Switch Output $t_{PHZ}, t_{PLZ}$	4051	0	2	-	225	-	-	-	280	-	-	-	340	-	-	ns
		0	4.5	-	45	-	45	-	56	-	56	-	68	-	68	ns
		0	6	-	38	-	-	-	48	-	-	-	57	-	-	ns
		-4.5	4.5	-	32	-	32	-	40	-	40	-	48	-	48	ns
	4052	0	2	-	250	-	-	-	315	-	-	-	375	-	-	ns
		0	4.5	-	50	-	50	-	63	-	63	-	75	-	75	ns
		0	6	-	43	-	-	-	54	-	-	-	65	-	-	ns
		-4.5	4.5	-	38	-	38	-	48	-	48	-	57	-	57	ns
	4053	0	2	-	210	-	-	-	265	-	-	-	315	-	-	ns
		0	4.5	-	42	-	44	-	53	-	55	-	63	-	66	ns
		0	6	-	36	-	-	-	45	-	-	-	54	-	-	ns
		-4.5	4.5	-	29	-	31	-	36	-	39	-	44	-	47	ns

**'HC4051, 'HCT4051, 'HC4052, CD74HCT4052, 'HC4053, CD74HCT4053**

**Switching Specifications**  $C_L = 50\text{pF}$ , Input  $t_r$ ,  $t_f = 6\text{ns}$  (Continued)

PARAMETER		$V_{EE}$ (V)	$V_{CC}$ (V)	AMBIENT TEMPERATURE, $T_A$												UNITS
				25°C				-40°C - 85°C				-55°C - 125°C				
				HC		HCT		HC		HCT		HC		HCT		
				MIN	MAX	MIN	MAX	MIN	MAX	MIN	MAX	MIN	MAX	MIN	MAX	
Maximum Switch Turn "On" Delay from S or E to Switch Output $t_{PZL}$ , $t_{PZH}$	4051	0	2	-	225	-	-	-	280	-	-	-	340	-	-	ns
		0	4.5	-	45	-	55	-	56	-	69	-	68	-	83	ns
		0	6	-	38	-	-	-	48	-	-	-	57	-	-	ns
		-4.5	4.5	-	32	-	39	-	40	-	49	-	48	-	59	ns
	4052	0	2	-	325	-	-	-	405	-	-	-	490	-	-	ns
		0	4.5	-	65	-	70	-	81	-	68	-	98	-	105	ns
		0	6	-	55	-	-	-	69	-	-	-	83	-	-	ns
		-4.5	4.5	-	46	-	48	-	58	-	60	-	69	-	72	ns
	4053	0	2	-	220	-	-	-	275	-	-	-	330	-	-	ns
		0	4.5	-	44	-	48	-	55	-	60	-	66	-	72	ns
		0	6	-	37	-	-	-	47	-	-	-	56	-	-	ns
		-4.5	4.5	-	31	-	34	-	39	-	43	-	47	-	51	ns
Input (Control) Capacitance, $C_I$	-	-	-	10	-	10	-	10	-	10	-	10	-	10	pF	

**Analog Channel Specifications** Typical Values at  $T_A = 25^\circ\text{C}$

PARAMETER	TEST CONDITIONS	HC/HCT TYPES	$V_{EE}$ (V)	$V_{CC}$ (V)	HC/HCT	UNITS
Switch Input Capacitance, $C_I$		All	-	-	5	pF
Common Output Capacitance, $C_{COM}$		4051	-	-	25	pF
		4052	-	-	12	pF
		4053	-	-	8	pF
Minimum Switch Frequency Response at -3dB, $f_{MAX}$ (Figures 12, 14, 16)	See Figure 3, Notes 9, 10	4051	-2.25	2.25	145	MHz
		4052			165	MHz
		4053			200	MHz
		4051	-4.5	4.5	180	MHz
		4052			185	MHz
		4053			200	MHz

勝特力材料 886-3-5753170  
 勝特力电子(上海) 86-21-54151736  
 勝特力电子(深圳) 86-755-83298787  
[Http://www.100y.com.tw](http://www.100y.com.tw)

**'HC4051, 'HCT4051, 'HC4052, CD74HCT4052, 'HC4053, CD74HCT4053**

**Analog Channel Specifications** Typical Values at  $T_A = 25^\circ\text{C}$

PARAMETER	TEST CONDITIONS	HC/HCT TYPES	$V_{EE}$ (V)	$V_{CC}$ (V)	HC/HCT	UNITS
Crosstalk Between any Two Switches (Note 12)	See Figure 4, Notes 10, 11	4051	-2.25	2.25	N/A	dB
		4052			(TBE)	dB
		4053			(TBE)	dB
		4051	-4.5	4.5	N/A	dB
		4052			(TBE)	dB
		4053			(TBE)	dB
Sinewave Distortion	See Figure 5	All	-2.25	2.25	0.035	%
		All	-4.5	4.5	0.018	%
$\bar{E}$ or S to Switch Feedthrough Noise	See Figure 6 Notes 10, 11	4051	-2.25	2.25	(TBE)	mV
		4052				mV
		4053				mV
		4051	-4.5	4.5	(TBE)	mV
		4052				mV
		4053				mV
Switch "OFF" Signal Feedthrough (Figures 13, 15, 17)	See Figure 7 Notes 10, 11	4051	-2.25	2.25	-73	dB
		4052			-65	dB
		4053			-64	dB
		4051	-4.5	4.5	-75	dB
		4052			-67	dB
		4053			-66	dB

NOTES:

9. Adjust input voltage to obtain 0dBm at  $V_{OS}$  for  $f_{IN} = 1\text{MHz}$ .
10.  $V_{IS}$  is centered at  $(V_{CC} - V_{EE})/2$ .
11. Adjust input for 0dBm.
12. Not applicable for HC/HCT4051.

**勝特力材料 886-3-5753170**  
**勝特力电子(上海) 86-21-54151736**  
**勝特力电子(深圳) 86-755-83298787**  
[Http://www.100y.com.tw](http://www.100y.com.tw)

Test Circuits and Waveforms

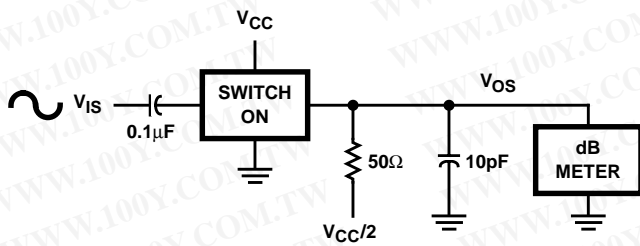

FIGURE 3. FREQUENCY RESPONSE TEST CIRCUIT

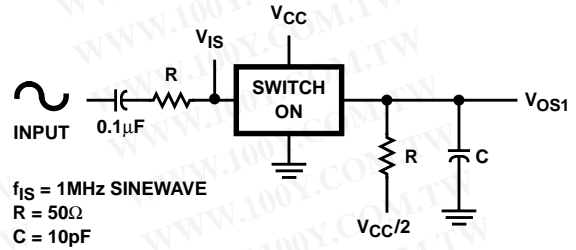

FIGURE 4. CROSSTALK BETWEEN TWO SWITCHES TEST CIRCUIT

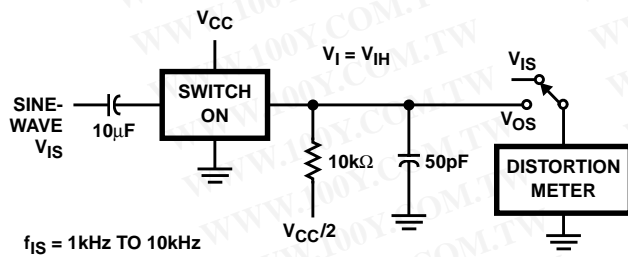
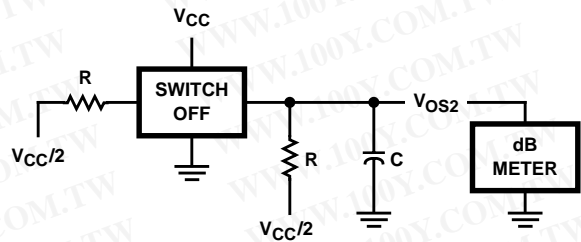

FIGURE 5. SINEWAVE DISTORTION TEST CIRCUIT

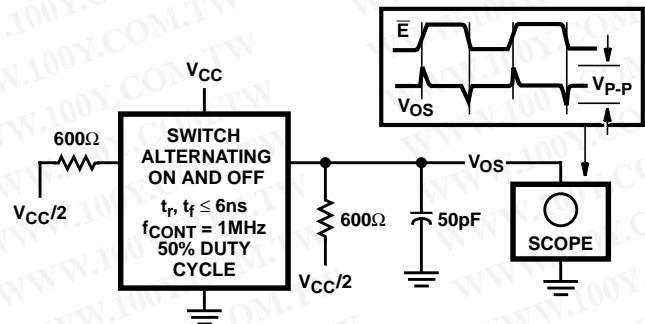

FIGURE 6. CONTROL TO SWITCH FEEDTHROUGH NOISE TEST CIRCUIT

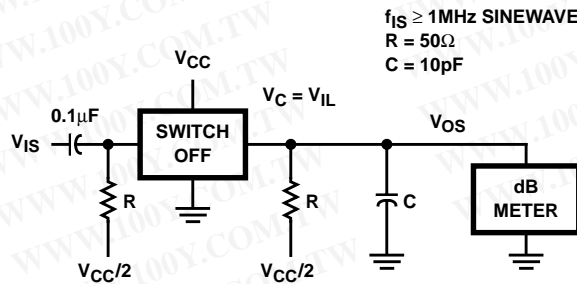

FIGURE 7. SWITCH OFF SIGNAL FEEDTHROUGH

勝特力材料 886-3-5753170  
 勝特力电子(上海) 86-21-54151736  
 勝特力电子(深圳) 86-755-83298787  
[Http://www.100y.com.tw](http://www.100y.com.tw)

Test Circuits and Waveforms (Continued)

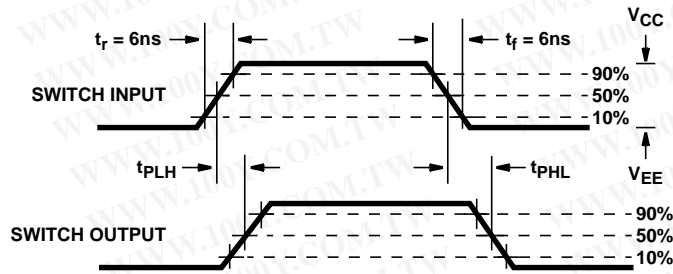

FIGURE 8A.

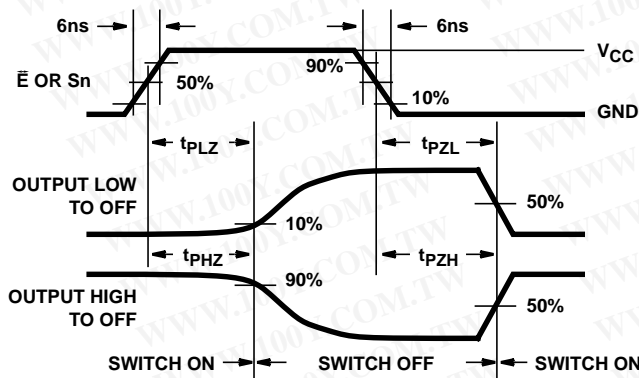

FIGURE 8B. HC TYPES

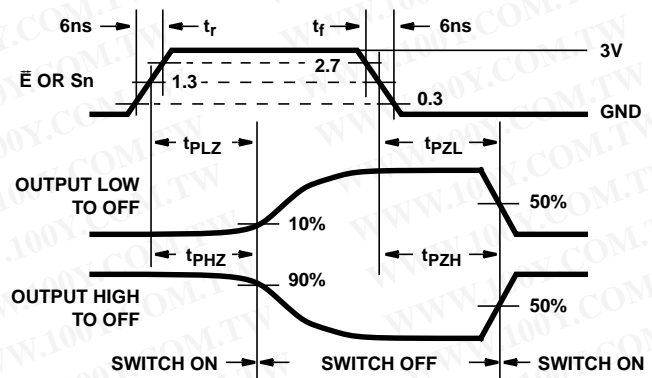

FIGURE 8C. HCT TYPES

FIGURE 8. SWITCH PROPAGATION DELAY, TURN-ON, TURN-OFF TIMES

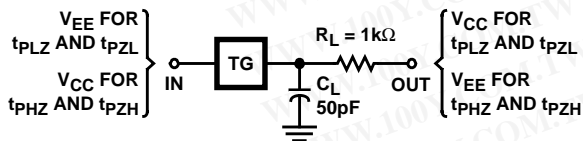

FIGURE 9. SWITCH ON/OFF PROPAGATION DELAY TEST CIRCUIT

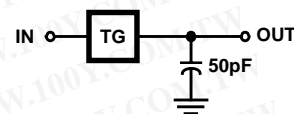
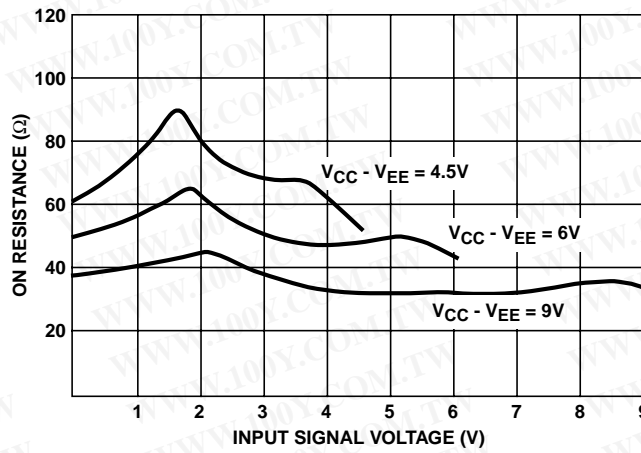

FIGURE 10. SWITCH IN TO SWITCH OUT PROPAGATION DELAY TEST CIRCUIT

勝特力材料 886-3-5753170  
 勝特力电子(上海) 86-21-54151736  
 勝特力电子(深圳) 86-755-83298787  
 Http://www.100y.com.tw

Typical Performance Curves



勝特力材料 886-3-5753170  
 勝特力电子(上海) 86-21-54151736  
 勝特力电子(深圳) 86-755-83298787  
[Http://www.100y.com.tw](http://www.100y.com.tw)

FIGURE 11. TYPICAL ON RESISTANCE vs INPUT SIGNAL VOLTAGE

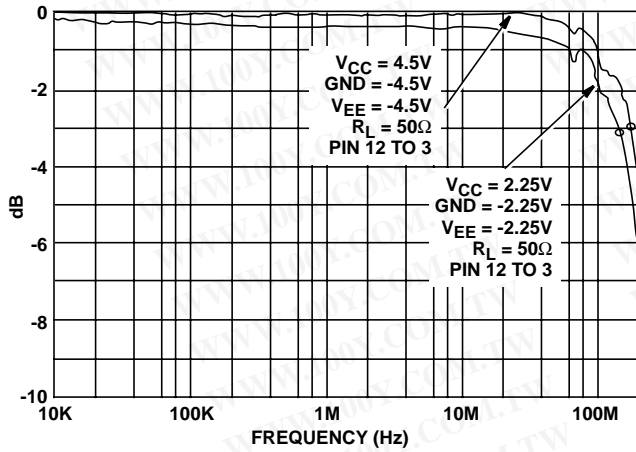

FIGURE 12. CHANNEL ON BANDWIDTH (HC/HCT4051)

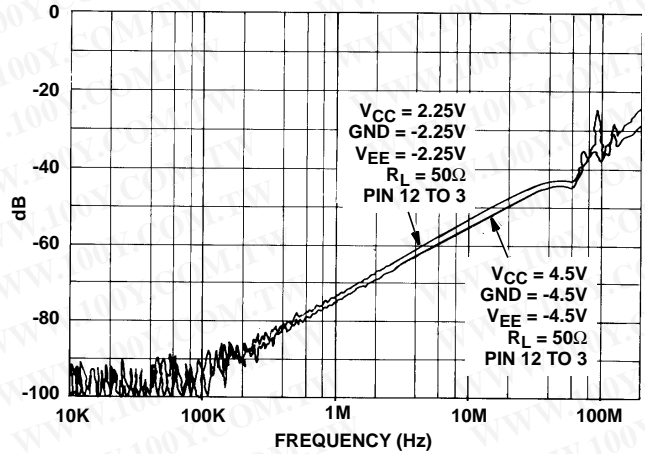

FIGURE 13. CHANNEL OFF FEEDTHROUGH (HC/HCT4051)

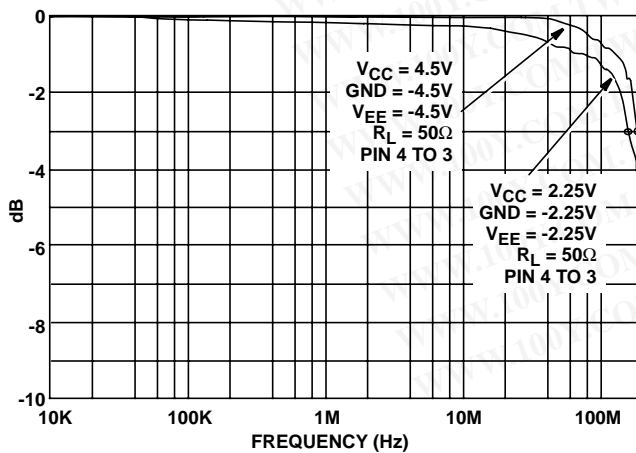

FIGURE 14. CHANNEL ON BANDWIDTH (HC/HCT4052)

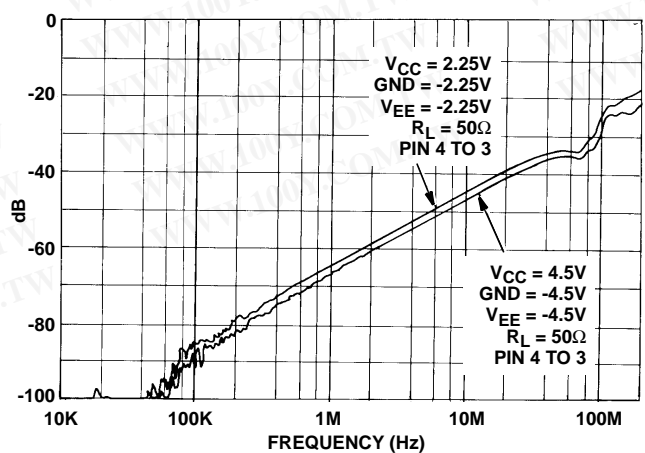

FIGURE 15. CHANNEL OFF FEEDTHROUGH (HC/HCT4052)

Typical Performance Curves (Continued)

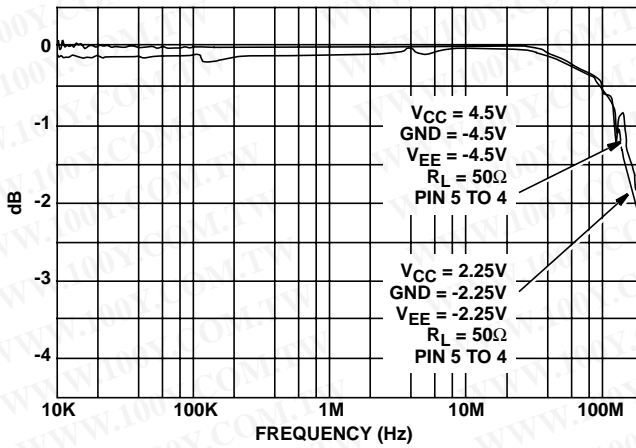

FIGURE 16. CHANNEL ON BANDWIDTH (HC/HCT4053)

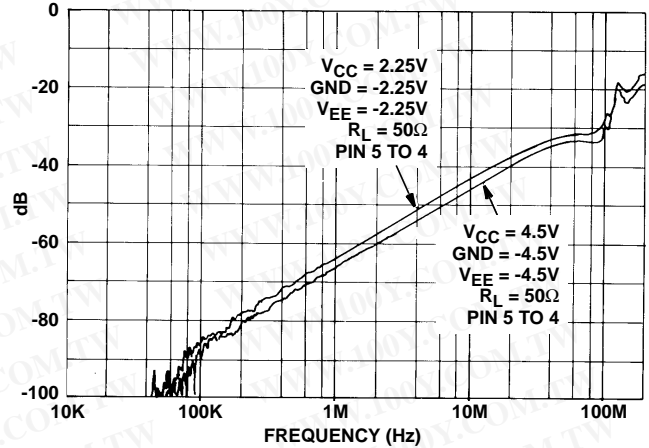

FIGURE 17. CHANNEL OFF FEEDTHROUGH (HC/HCT4053)

勝特力材料 886-3-5753170  
 勝特力电子(上海) 86-21-54151736  
 勝特力电子(深圳) 86-755-83298787  
[Http://www.100y.com.tw](http://www.100y.com.tw)

## IMPORTANT NOTICE

Texas Instruments and its subsidiaries (TI) reserve the right to make changes to their products or to discontinue any product or service without notice, and advise customers to obtain the latest version of relevant information to verify, before placing orders, that information being relied on is current and complete. All products are sold subject to the terms and conditions of sale supplied at the time of order acknowledgment, including those pertaining to warranty, patent infringement, and limitation of liability.

TI warrants performance of its semiconductor products to the specifications applicable at the time of sale in accordance with TI's standard warranty. Testing and other quality control techniques are utilized to the extent TI deems necessary to support this warranty. Specific testing of all parameters of each device is not necessarily performed, except those mandated by government requirements.

Customers are responsible for their applications using TI components.

In order to minimize risks associated with the customer's applications, adequate design and operating safeguards must be provided by the customer to minimize inherent or procedural hazards.

TI assumes no liability for applications assistance or customer product design. TI does not warrant or represent that any license, either express or implied, is granted under any patent right, copyright, mask work right, or other intellectual property right of TI covering or relating to any combination, machine, or process in which such semiconductor products or services might be or are used. TI's publication of information regarding any third party's products or services does not constitute TI's approval, warranty or endorsement thereof.

勝特力材料 886-3-5753170  
勝特力电子(上海) 86-21-54151736  
勝特力电子(深圳) 86-755-83298787  
[Http://www.100y.com.tw](http://www.100y.com.tw)

Copyright © 2000, Texas Instruments Incorporated